

# Manual for installation

## Green Box T+H



# Green Box T+H

Humidity and Temperature Sensor

Ag/MIS/UmEN-2738-05/19 Rev 1.9

P/N: 116791

 Munters

# Green Box T+H

## Manual for use and maintenance

Rev 1.9, 06/2024

This manual for use and maintenance is an integral part of the apparatus together with the attached technical documentation.

This document is destined for the user of the apparatus: it may not be reproduced in whole or in part, committed to computer memory as a file or delivered to third parties without the prior authorization of the assembler of the system.

Munters reserves the right to effect modifications to the apparatus in accordance with technical and legal developments.

# Index

<i>chapter</i>		<i>page</i>
<b>1</b>	<b>INTRODUCTION .....</b>	<b>4</b>
	1.1 Disclaimer.....	4
	1.2 Introduction .....	4
	1.3 Notes .....	4
<b>2</b>	<b>INTRODUCTION TO THE GREEN BOX T+H .....</b>	<b>5</b>
	2.1 Green Box Positioning.....	5
	2.2 Green Box Installation.....	6
	2.3 Green Box Connection Specifications and Wiring.....	6
<b>3</b>	<b>MAINTENANCE.....</b>	<b>10</b>
	3.1 Temperature Sensor.....	10
	3.2 Humidity Sensor .....	10
	3.3 Fan Replacement.....	11
	3.4 Fuse Replacement.....	12
<b>4</b>	<b>SPECIFICATIONS .....</b>	<b>13</b>
	4.1 Enclosure Specifications .....	13
	4.2 Cable Specifications .....	13
	4.3 Temperature Sensor Specifications .....	13
	4.4 Temperature Sensor Connections.....	14
	4.5 Humidity Sensor Specifications.....	14
<b>5</b>	<b>APPENDIX: WIRING INFORMATION.....</b>	<b>15</b>
<b>6</b>	<b>WARRANTY .....</b>	<b>16</b>

# 1 Introduction

## 1.1 Disclaimer

Munters reserves the right to make alterations to specifications, quantities, dimensions etc. for production or other reasons, subsequent to publication. The information contained herein has been prepared by qualified experts within Munters. While we believe the information is accurate and complete, we make no warranty or representation for any particular purposes. The information is offered in good faith and with the understanding that any use of the units or accessories in breach of the directions and warnings in this document is at the sole discretion and risk of the user.

## 1.2 Introduction

Congratulations on your excellent choice of purchasing a Green Box!

In order to realize the full benefit from this product it is important that it is installed, commissioned and operated correctly. Before installation or using the unit, this manual should be studied carefully. It is also recommended that it is kept safely for future reference. The manual is intended as a reference for installation, commissioning and day-to-day operation of Munters equipment.

## 1.3 Notes

Date of release: July 2019

Munters cannot guarantee to inform users about the changes or to distribute new manuals to them.

All rights reserved. No part of this manual may be reproduced in any manner whatsoever without the expressed written permission of Munters. The contents of this manual are subject to change without notice.

# 2 Introduction to the Green Box T+H

The Munters Green Box T+H is used to improve temperature and/or humidity measurement in a greenhouse or in any application requiring this data and when:

- solar radiation can affect the results
- microclimates can form

The Green Box (Figure 1) consists of a:

- plastic enclosure connected to a cable
- 6-wire cable
- fan
- temperature
- humidity sensor: The Green Box supports two different humidity sensors:
  - P/N: 960-08-00007 GREEN BOX-GRH-EN-MUR-T & HIGH RH SENSOR
  - P/N: 960-08-00005 GREEN BOX-GRH-EN-MUR-T-RH (Standard Sensor)

The sensors' installation and maintenance are the same. Refer to [Humidity Sensor Specifications](#), page 14 for details on these sensors' specifications.

In addition, the unit comes with:

- Connection Box (Figure 2), connected to a 6-wire 10.5 meter cable
- Five meter chain (attached to the Green Box cable)
- S Hook
- Two mounting brackets
- Two roundhead screws (use these to attach the mounting brackets to the Connection Box)
- Two flathead screws (use these to attach the mounting brackets to a wall/wood sheet)

## 2.1 Green Box Positioning

Position the Green Box in a representative spot. Choose a location that is not highly vulnerable, so the Green Box isn't damaged, for example not too close to a heater or to the path.

- In short crops it is recommended to position the Green Box about 30 cm (12 inches) above the crop, in an area that is relatively not influenced by metal and other irrelevant factors like a path, sprayer, etc.
- In tall crops it is recommended to position the Green Box around the middle of the crop height, in an area that is relatively not influenced by metal and other irrelevant factors like a path, sprayer, etc.

## 2.2 Green Box Installation

**WARNING!** Only an authorized electrical technician may perform this procedure!

1. Using the supplied chain, hang the Green Box in the required location. Use the supplied S hook.
2. Using the supplied clips, install the Connection Box in the required location.

**CAUTION** The Connection Box has a 10.5 meter cable that connects it to the Green Box. Make sure that you install the Connection Box within this distance to the Green Box.

**NOTE** If you place the Green Box in a high position (high crops) make sure to leave enough cable so that the Green Box can be lowered down for maintenance purposes.

3. The Green Box and Connection Box come with the wiring installed. The user needs to wire the Connection Box to the controller analog input card and power supply (Figure 3).

**CAUTION** Do not use electrical cable to hang the unit!

## 2.3 Green Box Connection Specifications and Wiring

The Green Box is wired to the controller using a 6-wire shielded cable as follows:

- 24 VAC for the fan
- 24 VAC for the fan
- Temperature output
- Relative humidity output
- 12 VDC for the RH sensor
- Common

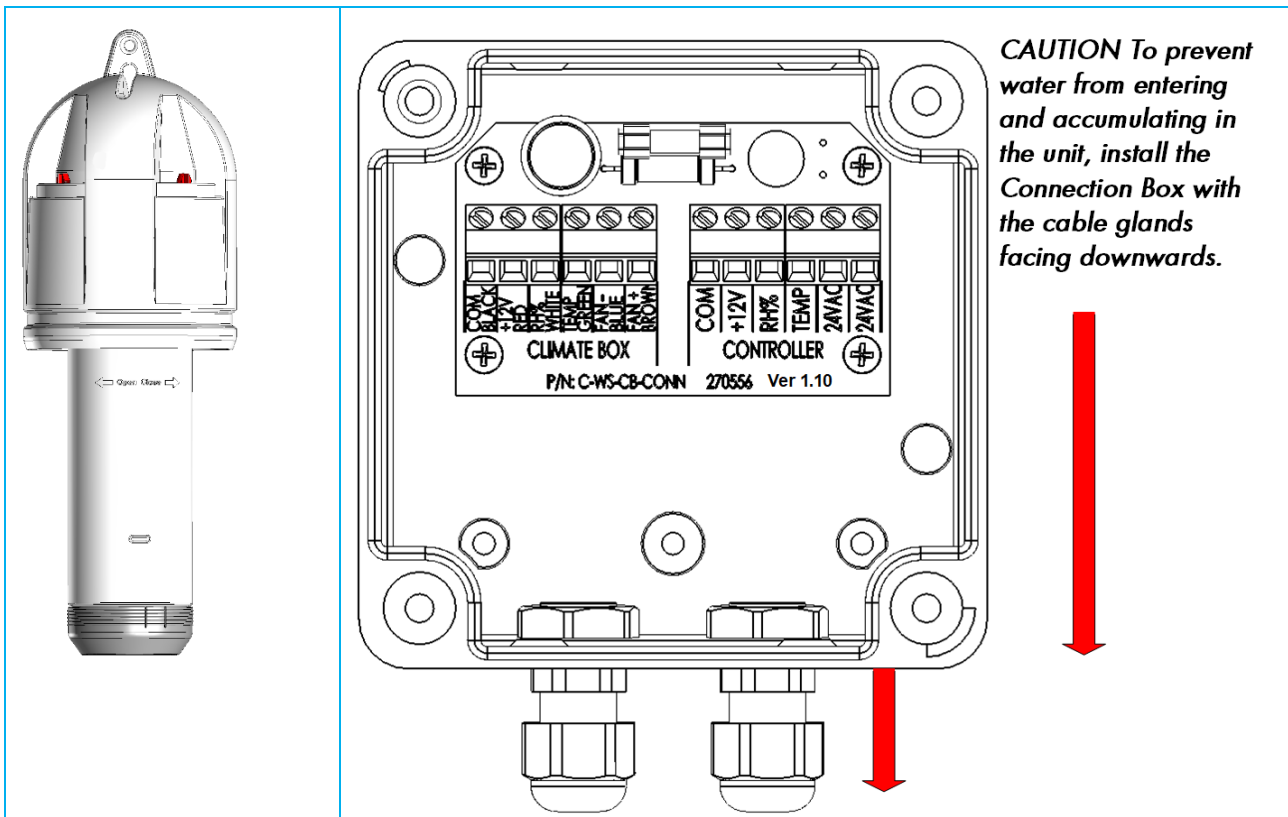

Figure 1: Green Box unit

Figure 2: Connection Box

1. Wire the Connection Box to the controller as shown in Figure 3.

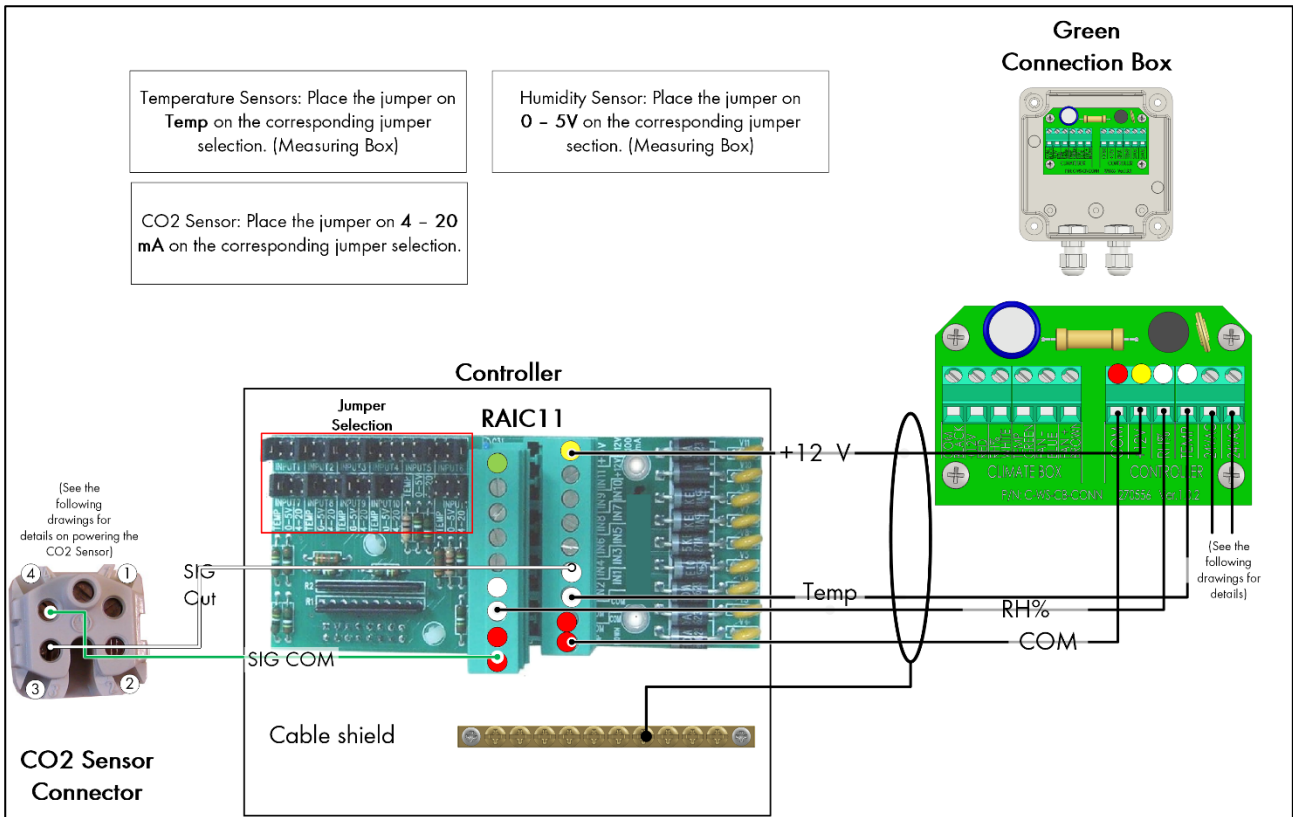

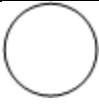



Figure 3: Green Connection Box - Controller RAIC11 wiring (example)

NOTE The above diagram is an example only. The RTS Temperature Sensor and RHS+ Humidity Sensor can be wired to any RAIC11 input port.

- The shield should be connected to the ground on one side only.
- The Green Box Connection Box comes prewired to the sensors. Those wires are not shown in Figure 1.
- Refer to Figure 4 to see an expanded picture of the jumpers.
- Refer to Figure 5 for details on the fan power supply.

	COM Ports
	12 Volt Port (Humidity Sensor)
	SIGNAL PORTS (Temperature or Humidity Sensor)
	5 Volt

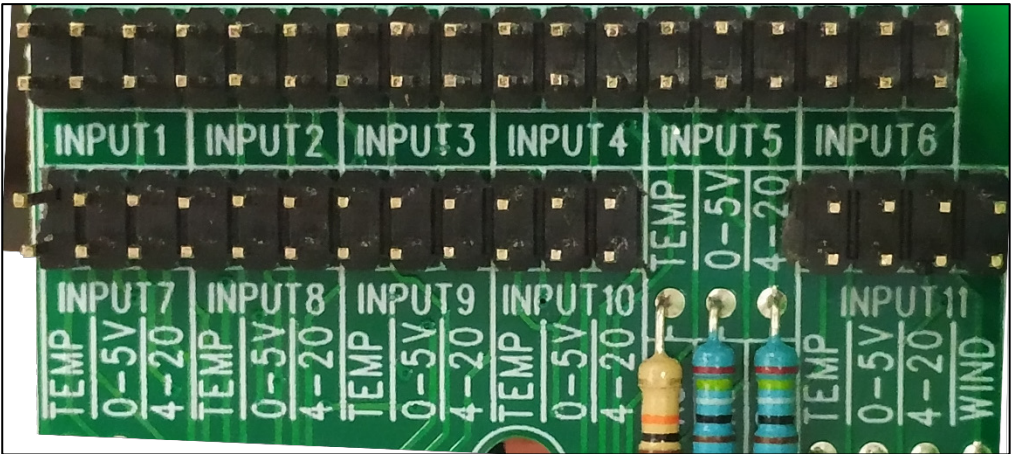

Figure 4: Jumpers - Expanded

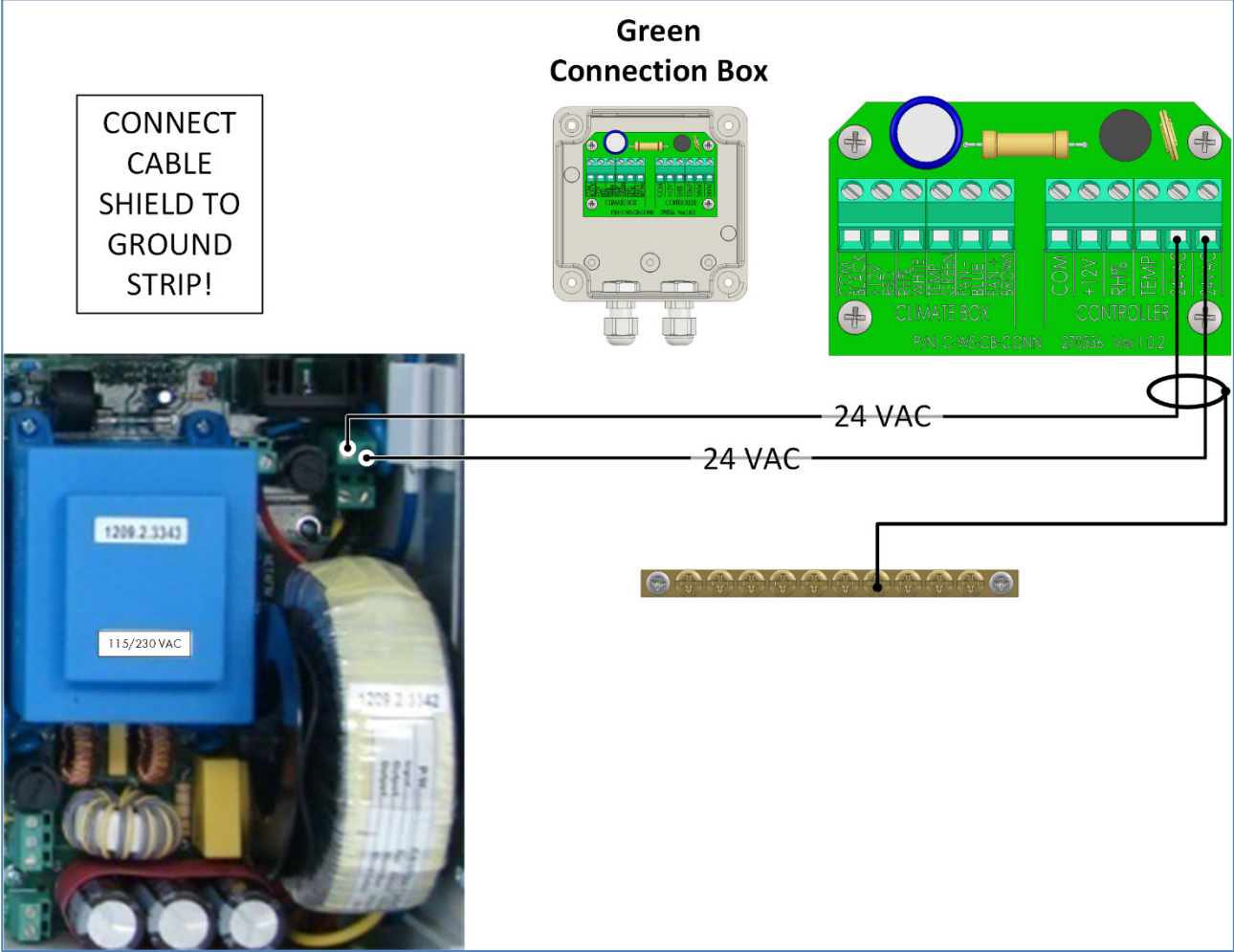

Figure 5: Powering the Fan



2. Strip the Connection Box shield cables and wrap them together as shown in Figure 6.

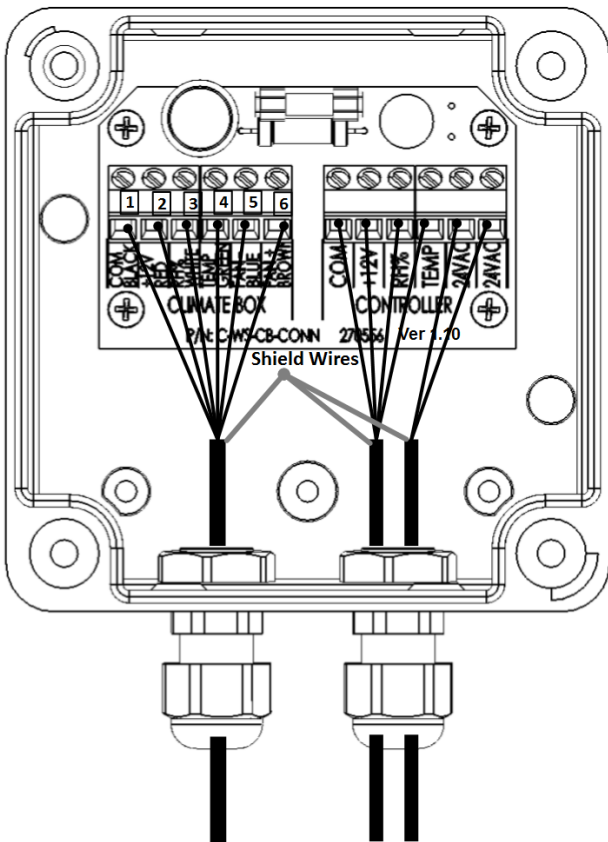

Figure 6: Connection Box shield cables wrap

# 3 Maintenance

Periodically inspect the fan for excess dust build up.

## 3.1 Temperature Sensor

The temperature sensor requires no maintenance.

## 3.2 Humidity Sensor

This procedure describes how to replace the humidity sensor head assembly.

1. Unscrew the box tip and locate the humidity sensor.

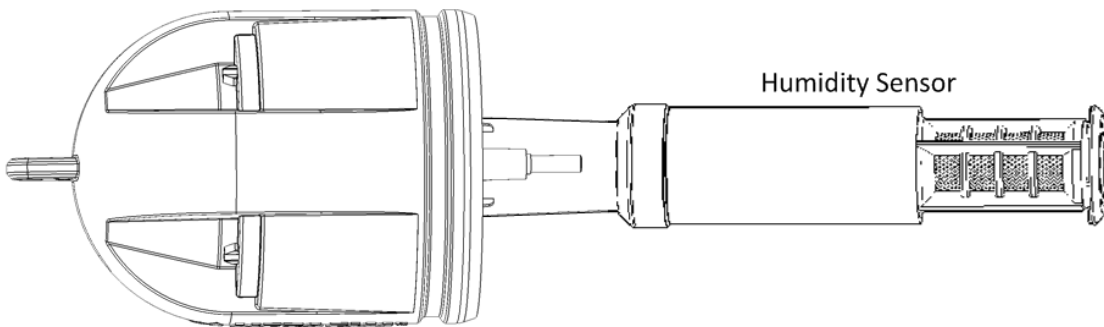

Figure 7: Box tip removed

2. Untwist the filter.

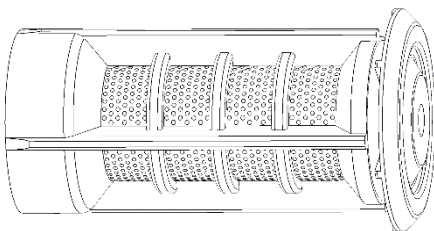

Figure 8: Filter

3. Pull out the sensor assembly.

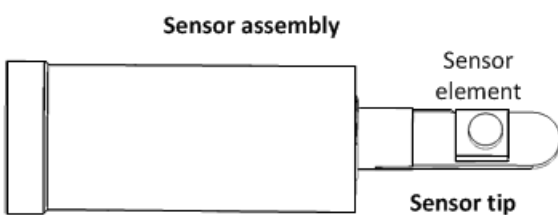

Figure 9: Sensor assembly

**CAUTION** Do not touch the sensor element!

4. Remove the Sensor Tip.

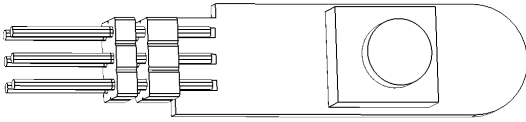

Figure:10 Sensor Tip

5. Put a new Sensor tip in place and replace the filter.

*NOTE Note: Insert the Sensor Tip gently, with the pins going in completely. If the Sensor Tip does not go in completely, pull it out, turn it over and reinsert.*

### 3.3 Fan Replacement

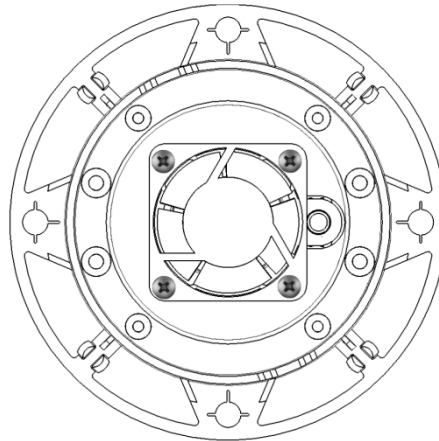

Figure:11 Unit fan

1. Disconnect the fan's red and black wires from the wire connectors.
2. Unscrew the fan, remove the unit, and place the new unit in place.
3. Connect the fan's red and black wire to the wire connector:
  - Black wire is inserted into the connector opposite the blue wire.
  - Red wire is inserted into the connector opposite the brown wire.

### 3.4 Fuse Replacement

The Connection Box comes equipped with a 160 mA fuse. In addition, Munters provides a spare fuse (in a small plastic bag).

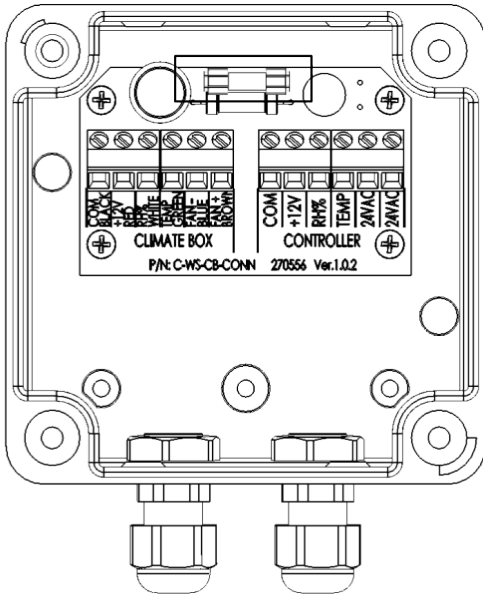

Figure:12 Fuse location

1. Disconnect the Connection Box' power supply.
2. Open the Box, remove the fuse, and replace it with the spare.
3. Recover the box and apply power.

# 4 Specifications

## 4.1 Enclosure Specifications

Input power	<ul style="list-style-type: none"> <li>• 24Vac, 100 mA, , 50/60 Hz</li> <li>• 12Vdc, 10 mA</li> </ul>
<i>NOTE Unit should be powered by Limited Energy Source per IEC 61010-1 or Limited Power Source per IEC 60950-1 or IEC 62368-1.</i>	
Green Box maximum ambient temperature	+60° C/140° F
<b>Environmental Specifications</b>	
<p>Indoor use only</p> <p>Altitude: -400 m to 2000 m/-1300 ft. to 6600 ft.</p> <p>Relative Humidity: 0 – 95%</p> <p>Main supply voltage fluctuation up to 5%</p> <p>Overvoltage category: OVCII</p> <p>Pollution degree: PD2</p> <p>Ingress Protection: IPX0</p>	

## 4.2 Cable Specifications

Sensor Cable Type	4 Wire Shielded Cable, 22 AWG (minimum)
24V Cable Type	2 Wire Shielded Cable, 22 AWG (minimum)
Maximum Cable Length (between the controller and Connection Box)	300 meter (985 feet)

**WARNING: TO ENSURE INTERFERENCE AND LIGHTNING IMMUNITY, USE SHIELDED CABLE ONLY!**

**WARNING: POWER AND SIGNAL WIRES MUST BE IN SEPARATE CABLES!**

## 4.3 Temperature Sensor Specifications

Type	30K Ohm Thermistor at (25° C/77°F)
Curve Number	1
Maximum 25°C/77°F Tolerance	±3%
Operating Temperature	0° - 60° C/32° - 140° F

#### 4.4 Temperature Sensor Connections

Red	Output 30kOHM
Black	Common
Shield	Safety Ground

#### 4.5 Humidity Sensor Specifications

Input voltage	10 - 13 VDC
Output voltage	0 - 3 VDC
Temperature range	0° - 60° C/32° - 140° F
<b>Accuracy at 20° C/68° F</b>	
<b>60% RH</b>	<b>± 2.5%</b>
<b>80% RH</b>	<b>± 1.0%</b>
<b>95% RH</b>	<b>± 0.4%</b>

*NOTE For information regarding the accuracy at different relative humidities or temperatures, please contact MIS Customer Success.*

# 5 Appendix: Wiring Information

In the event that you need to rewire the Green Box to the Connection Box, use the following tables as a guide.

*Table 1: Green Box Wiring*

Temperature Sensor	Humidity Sensor	24 VDC Fan	6-Wire Cable (Short cable)
Black	Black	–	Black
Red	Green (N.C.)	–	Green
–	Red	–	Red
–	–	Black	Blue
–	–	Red	Brown
–	White	–	White
Shield (N.C)	Shield (N.C)	–	Shield (N.C)

*Table 2: Connection Box Wiring*

6 Wire Cable (10 meter)	Green Box Terminal
Black	COM
Green	Temperature
Red	+12V
Blue	Fan –
Brown	Fan +
White	RH
Shield (N.C)	–

# 6 Warranty

## Warranty and technical assistance

Munters products are designed and built to provide reliable and satisfactory performance but cannot be guaranteed free of faults; although they are reliable products they can develop unforeseeable defects and the user must take this into account and arrange adequate emergency or alarm systems if failure to operate could cause damage to the articles for which the Munters plant was required: if this is not done, the user is fully responsible for the damage which they could suffer.

Munters extends this limited warranty to the first purchaser and guarantees its products to be free from defects originating in manufacture or materials for one year from the date of delivery, provided that suitable transport, storage, installation and maintenance terms are complied with. The warranty does not apply if the products have been repaired without express authorisation from Munters, or repaired in such a way that, in Munters' judgement, their performance and reliability have been impaired, or incorrectly installed, or subjected to improper use. The user accepts total responsibility for incorrect use of the products.

The warranty on products from outside suppliers fitted to Green Box, (for example Green Box' power supplies, cables, etc.) is limited to the conditions stated by the supplier: all claims must be made in writing within eight days of the discovery of the defect and within 12 months of the delivery of the defective product. Munters has thirty days from the date of receipt in which to take action, and has the right to examine the product at the customer's premises or at its own plant (carriage cost to be borne by the customer).

Munters at its sole discretion has the option of replacing or repairing, free of charge, products which it considers defective, and will arrange for their despatch back to the customer carriage paid. In the case of faulty parts of small commercial value which are widely available (such as bolts, etc.) for urgent despatch, where the cost of carriage would exceed the value of the parts, Munters may authorise the customer exclusively to purchase the replacement parts locally; Munters will reimburse the value of the product at its cost price.

Munters will not be liable for costs incurred in demounting the defective part, or the time required to travel to site and the associated travel costs. No agent, employee or dealer is authorised to give any further guarantees or to accept any other liability on Munters' behalf in connection with other Munters products, except in writing with the signature of one of the Company's Managers.

**WARNING:** In the interests of improving the quality of its products and services, Munters reserves the right at any time and without prior notice to alter the specifications in this manual.

The liability of the manufacturer Munters ceases in the event of:

- dismantling the safety devices;
- use of unauthorised materials;



- inadequate maintenance;
- use of non-original spare parts and accessories.

Barring specific contractual terms, the following are directly at the user's expense:

- preparing installation sites;
- providing an electricity supply (including the protective equipotential bonding (PE) conductor, in accordance with CEI EN 60204-1, paragraph 8.2), for correctly connecting the equipment to the mains electricity supply;
- providing ancillary services appropriate to the requirements of the plant on the basis of the information supplied with regard to installation;
- tools and consumables required for fitting and installation;
- lubricants necessary for commissioning and maintenance.

It is mandatory to purchase and use only original spare parts or those recommended by the manufacturer.

Dismantling and assembly must be performed by qualified technicians and according to the manufacturer's instructions.

The use of non-original spare parts or incorrect assembly exonerates the manufacturer from all liability.

Requests for technical assistance and spare parts can be made directly to the nearest [Munters office](#).

