

Instruction Manual

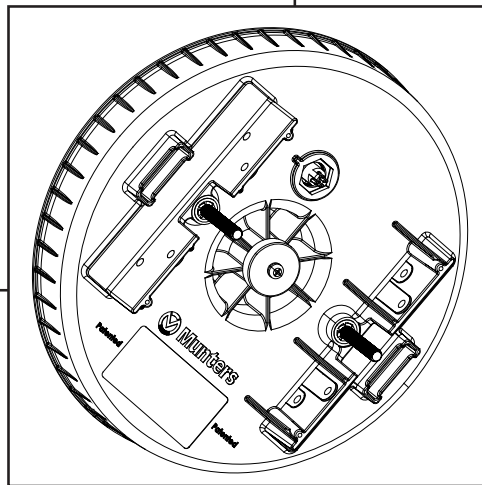
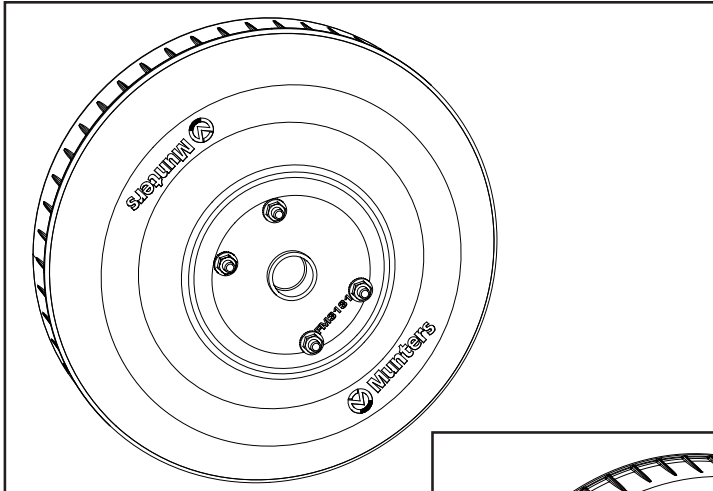

"FM"
Munters Drive *
Motor
Replacement Kit
for WM Fans

*Patents Pending

"FM" Munters Drive

Motor and Controller Replacement Kit

Models: FM1236H • FM1236L



FM - Munters Drive

Motor Replacement Kit

Instructions for Use and Maintenance

Thank You:

Thank you for purchasing a "FM" motor replacement kit. Munters equipment is designed to be the highest performing, highest quality equipment you can buy. With the proper installation and maintenance it will provide many years of service.

Please Note:

To achieve maximum performance and insure long life from your Munters product it is essential that it be installed and maintained properly. Please read all instructions carefully before beginning installation.

Warranty:

For Warranty claims information see the "Warranty Claims and Return Policy" form QM1021 available from the [Munters Corporation office at 1-800-227-2376 or by e-mail at aghort.info@munters.com](mailto:aghort.info@munters.com).

Conditions and Limitations:

- Products and Systems involved in a warranty claim under the "Warranty Claims and Return Policy" shall have been properly installed, maintained and operated under competent supervision, according to the instructions provided by Munters Corporation.
- Malfunction or failure resulting from misuse, abuse, negligence, alteration, accident or lack of proper installation or maintenance shall not be considered a defect under the Warranty.

Index

Chapters	Page
1. Unpacking the Equipment	4
1.1 Parts List	4
2. Installation Instructions	5
2.1 Motor Installation	8
2.2 Controller Reinstallation	8
3. Troubleshooting	10

Unpacking the Equipment

1.

1.1 Parts List

Before beginning installation, check the overall condition of the equipment. Remove packing materials, and examine all components for signs of shipping damage. Any shipping damage is the customer's responsibility and should be reported immediately to your freight carrier.

Each "FM" Munters Drive Kit Includes:

- 1 - Munters Drive Motor
- 1 - Hardware Package As Follows:

HP1324 - Hardware Package for "FM" Kit

ID	Qty.	Cat. No.	Description
[A]	2	KN1850	M10-1.5 x 10mm Hex Nut, ZP
[B]	2	KW3509	M10, Splitlock Washer, ZP
[C]	2	KW3016	7/16" Type-A Wide Flat Washer, ZP
[D]	4	KS1019	1/4"-20 x 1" Hex Head Bolt, SS
[E]	4	KW3002	1/4" Type-A Narrow Flat Washer, SS
[F]	4	KN0702	1/4"-20 Serrated Flange Hex Nut, SS
[G]	1	KX1157	1" Dia. Hole Plug, Black Rubber

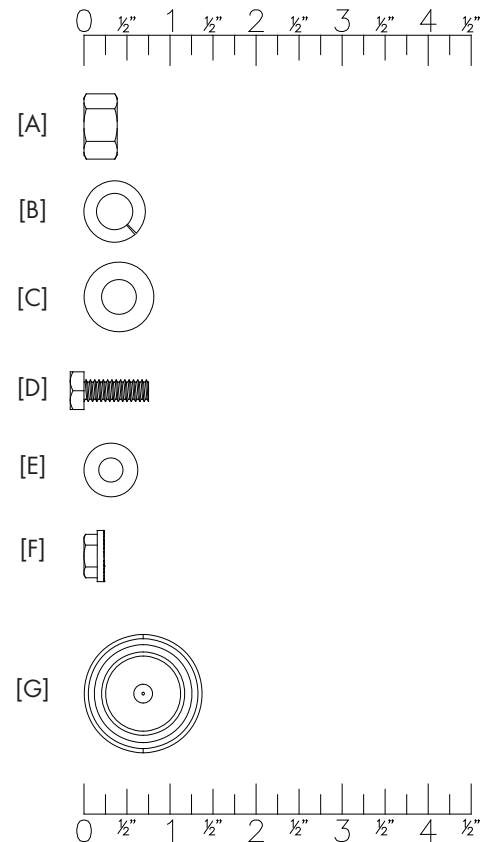

Installation Instructions

2.

Step 1

Disconnect power from fan before continuing. Remove the guard from the back of the fan and set safely aside to be reinstalled later. [See Figure 1.](#)

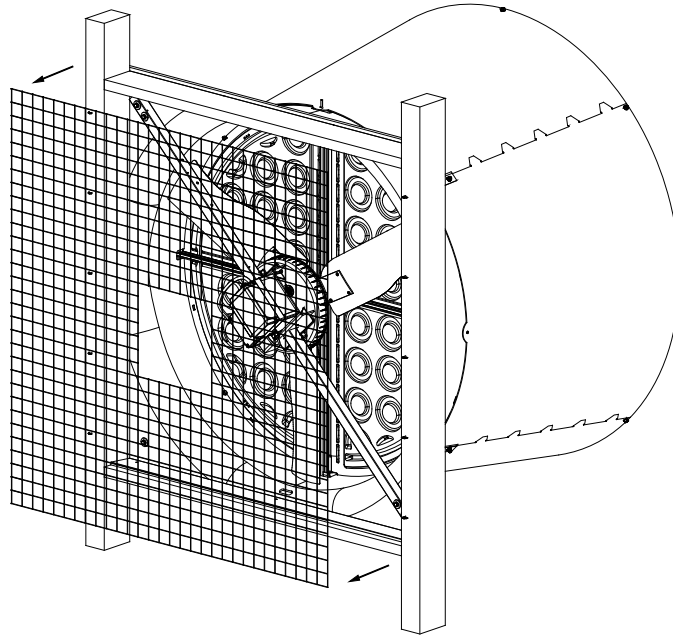

Figure 1

Step 2

Remove the 4 nuts holding the Propeller to the Munters Drive Motor and set safely into the cone to be reused. [See Figure 2.](#)

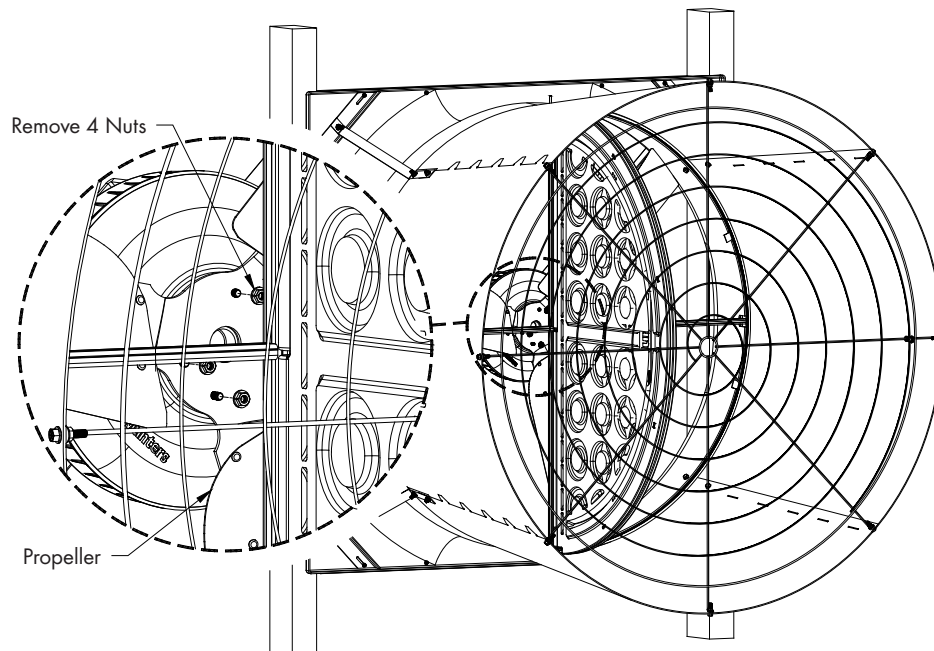
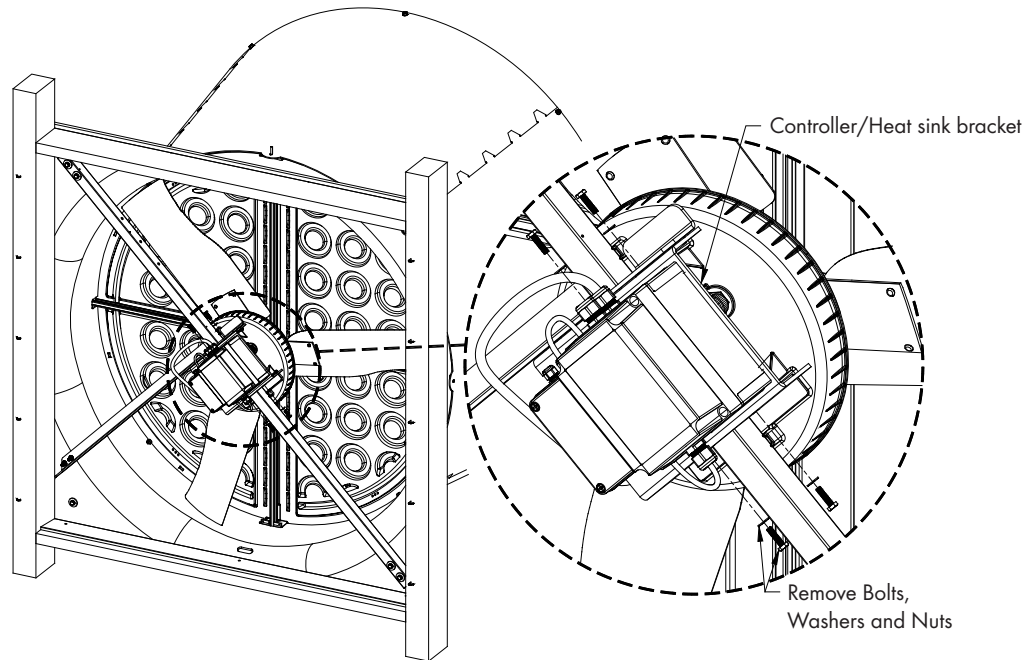

Figure 2

Step 3

Remove the 4 bolts and nuts holding the controller/heat sink bracket to the Munters Drive Motor and disconnect quick connect cable from back of motor. Then carefully set controller aside. See Figure 3.



Fan with Old Controller

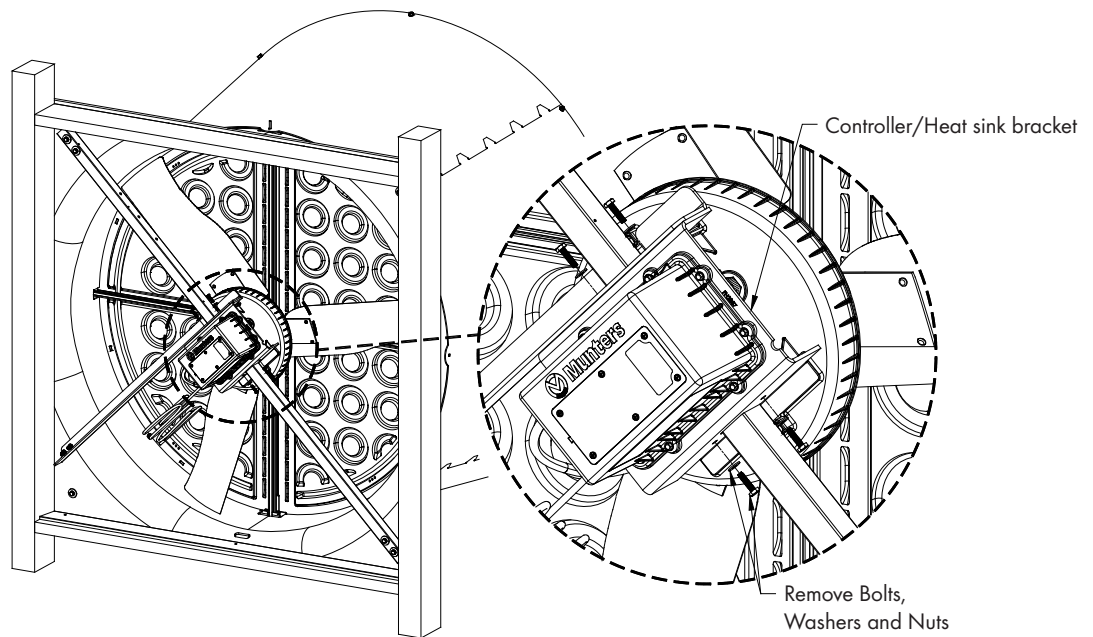

Fan with New Controller

Figure 3

Step 4

Remove the motor from the struts by removing the 2 Nuts and Washers holding the motor to the struts. Motor is heavy, make sure to support it while removing bolts so it does not fall and damage housing or motor. See Figure 4.

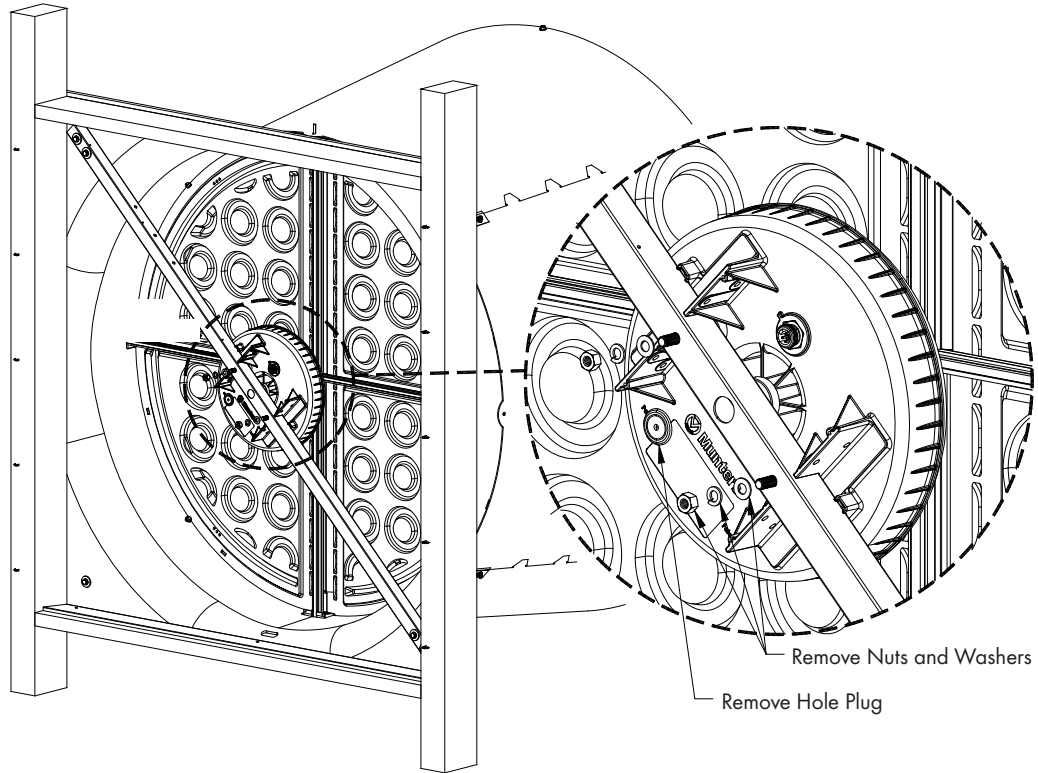

Figure 4

Step 5

Locate box and make sure it is facing up and open the box. Remove the top section of the foam packaging to reveal the Munters Drive Motor. See Figure 5.

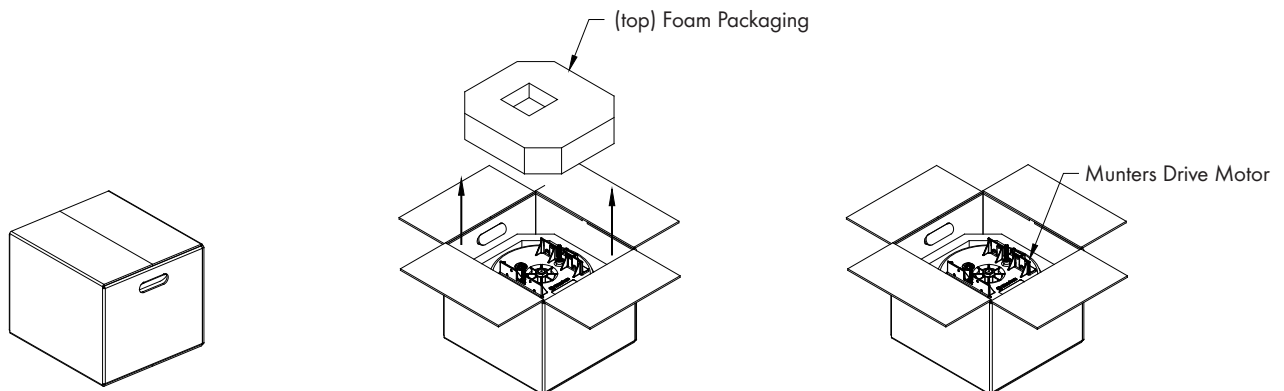

Figure 5

2.1 Motor Installation

Step 6

Carefully lift motor into place with the strut running through the motor flanges and insert the mounting bolts on the motor into holes in strut and secure in place using (2) Washers [C], Splitlock Washers [B] and Nuts [A].

See Figure 6.

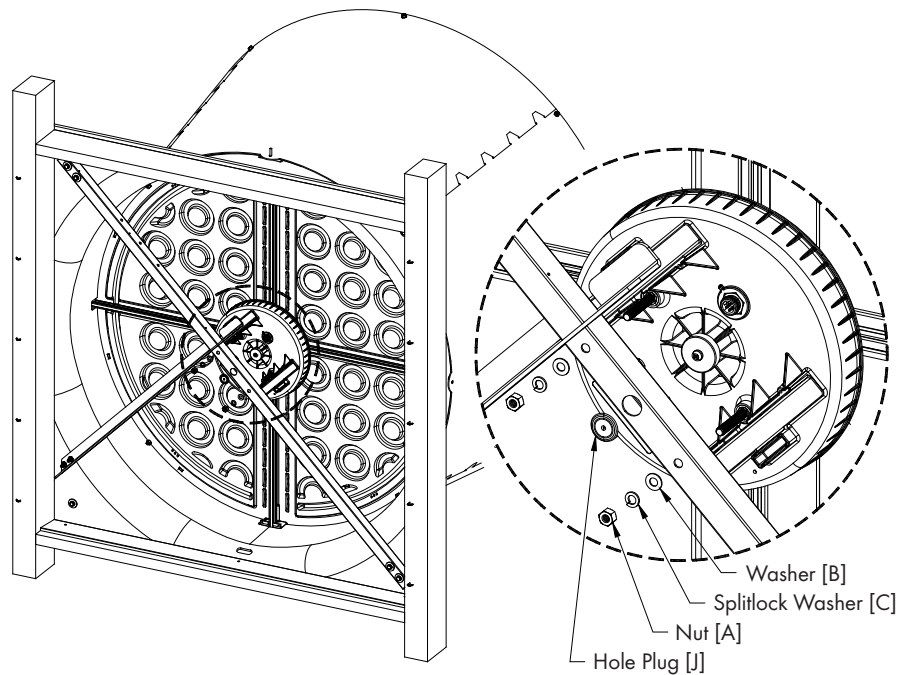

Figure 6

Step 7

Reconnect the quick connect connector to the motor. Then reposition Munters Drive Controller mounting bracket over strut with the left flange of bracket between Motor flange and Support Bracket and fasten in place with (4) Bolts [D], Washers [E] and Nuts [F]. See Figure 7.

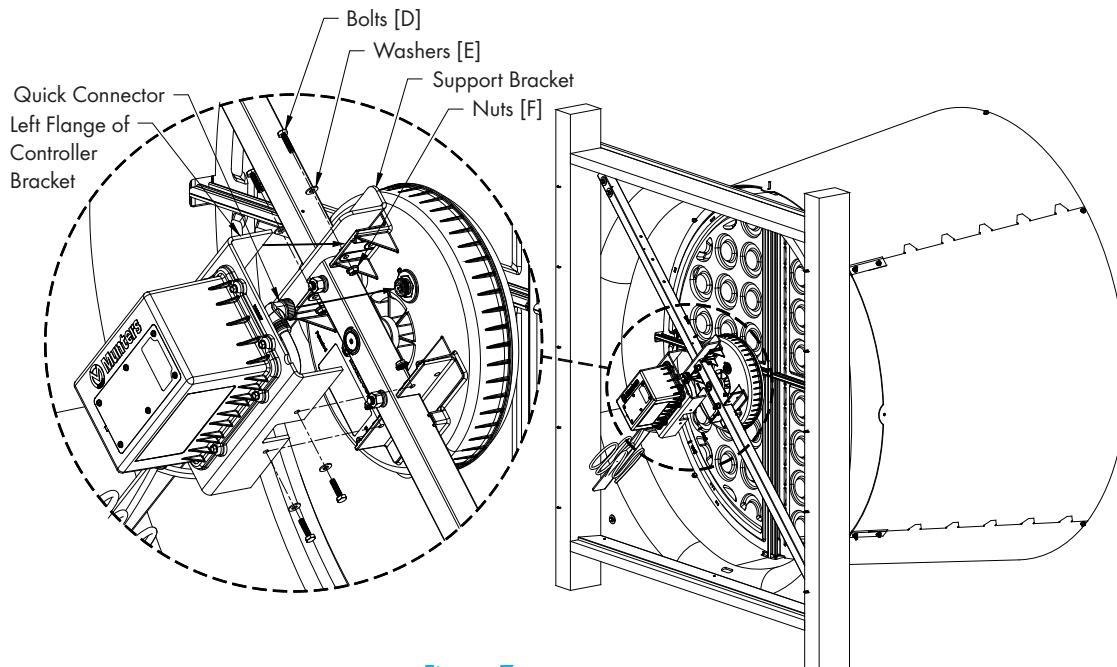

Figure 7

Step 8

Remove (4) nuts from face of the Munters Drive Motor. Position propeller onto bolts of Munters Drive Motor and secure with (4) nuts just removed. Tighten the nuts to 200 in-lbs. of torque. See [Figure 8](#).

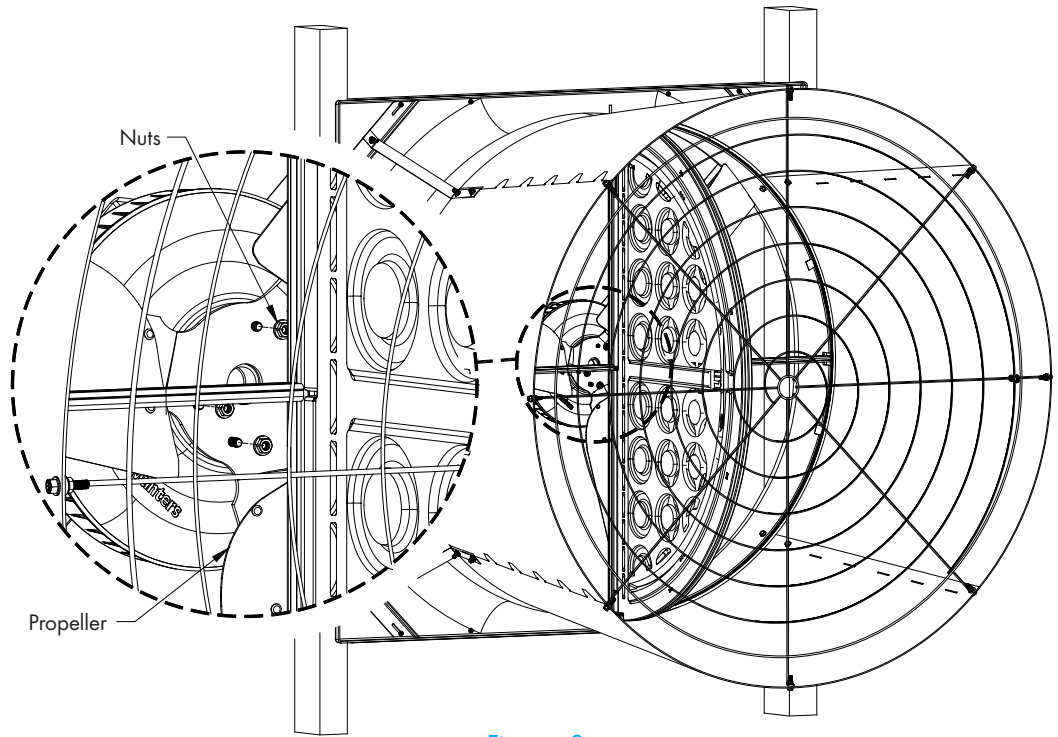
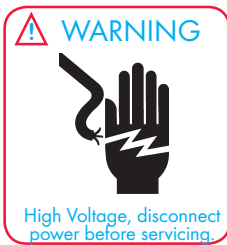

Figure 8

4.1 Troubleshooting



SYMPTOM	POSSIBLE CAUSES	CORRECTIVE ACTION
<ul style="list-style-type: none"> Fan Not Operating 	<ul style="list-style-type: none"> Fan control set above room temperature Blown Fuse or open circuit breaker Propeller blade contacting fan housing Fan control defective (i.e. environmental control, etc.) 	<ul style="list-style-type: none"> Set to a lower temperature Replace fuse or reset breaker Realign motor in fan housing Repair or replace control
<ul style="list-style-type: none"> Fan Does Not Start Caution: There is a 10 second delay for the fan to start when an 'On' command is present. 	<ul style="list-style-type: none"> Munters Drive motor/controller issue 	<ol style="list-style-type: none"> Verify AC voltage is present at fan. Turn AC power off to fan for 1 minute Verify Prop turns freely <ol style="list-style-type: none"> If not contact Munters Product Support If it turns freely go to next step Turn AC power back on to fan <ol style="list-style-type: none"> If starts up and runs, fan OK <ul style="list-style-type: none"> Periodically observe fan to verify it is still running If it continues to run, fan is OK If fan stops, look through clear window in drive cover to check what drive display reads. Contact Munters Product Support If fan tries to start but stops, look through clear window in drive cover to check what drive display reads. Contact Munters Product Support If fan doesn't try to start, verify 'On' command signal is present at circuit board. Also, slide the switch on the circuit board to the 'On' position.
<ul style="list-style-type: none"> Fan Operating - Insufficient Airflow 	<ul style="list-style-type: none"> Shutter or Damper door jammed Guard dirty/clogged 10-0V signal set incorrectly 	<ul style="list-style-type: none"> Clean shutter or damper door Clean guard Check and adjust 10-0V signal
<ul style="list-style-type: none"> Excessive Noise 	<ul style="list-style-type: none"> Propeller blade contacting fan housing 	<ul style="list-style-type: none"> Sand fan housing to remove high spot
<ul style="list-style-type: none"> Excessive Vibration 	<ul style="list-style-type: none"> Motor loose on mount Propeller damaged 	<ul style="list-style-type: none"> Tighten fasteners Replace propeller

This page left blank intentionally

Munters Drive replacement kit is developed and produced by Munters Corporation, Lansing, Michigan U.S.A. 1-800-227-2376



Munters Europe AB, Isafjordsgatan 1, P.O. Box 1150, SE-164 26 Kista, Sweden. Phone +46 08 626 63 00, Fax +46 8 754 56 66.

Munters Corporation 2691 Ena Drive Lansing, MI 48917 U.S.A. Phone +1 800-227-2376, Fax +1 517-676-7078

www.munters.us

[Australia](#) Munters Pty Limited, Phone +61 2 6025 6422, [Brazil](#) Munters Brasil Industria e Comercio Ltda, Phone +55 41 3317 5050, [Canada/US](#) Munters Corporation Lansing, MI Phone +1 517 676 7070, [China](#) Munters Air Treatment Equipment (Beijing) Co. Ltd, Phone +86 10 80 481 121, [Denmark](#) Munters A/S, Phone +45 9862 3311, [India](#) Munters India, Phone +91 20 3052 2520, [Indonesia](#) Munters, Phone +62 818 739 235, [Italy](#) Munters Italy S.p.A., Chiusavecchia, Phone +39 0183 52 11, [Japan](#) Munters K.K., Phone +81 3 5970 0021, [Korea](#) Munters Korea Co. Ltd., Phone +82 2 761 8701, [Mexico](#) Munters Mexico, Phone +52 818 262 54 00, [Russia](#) Munters AB, Phone +7 812 448 5740, [Singapore](#) Munters Pte Ltd., Phone +65 744 6828, [South Africa and Sub-Sahara Countries](#) Munters (Pty) Ltd., Phone +27 11 997 2000, [Spain](#) Munters Spain S.A., Phone +34 91 640 09 02, [Sweden](#) Munters AB, Phone +46 8 626 63 00, [Thailand](#) Munters Co. Ltd., Phone +66 2 642 2670, [Turkey](#) Munters Form Endüstri Sistemleri A.Ş., Phone +90 322 231 1338, [USA](#) Munters Corporation Lansing, MI Phone +1 517 676 7070, [Vietnam](#) Munters Vietnam, Phone +84 8 3825 6838, [Export & Other countries](#) Munters Italy S.p.A., Chiusavecchia Phone +39 0183 52 11