

Instruction Manual

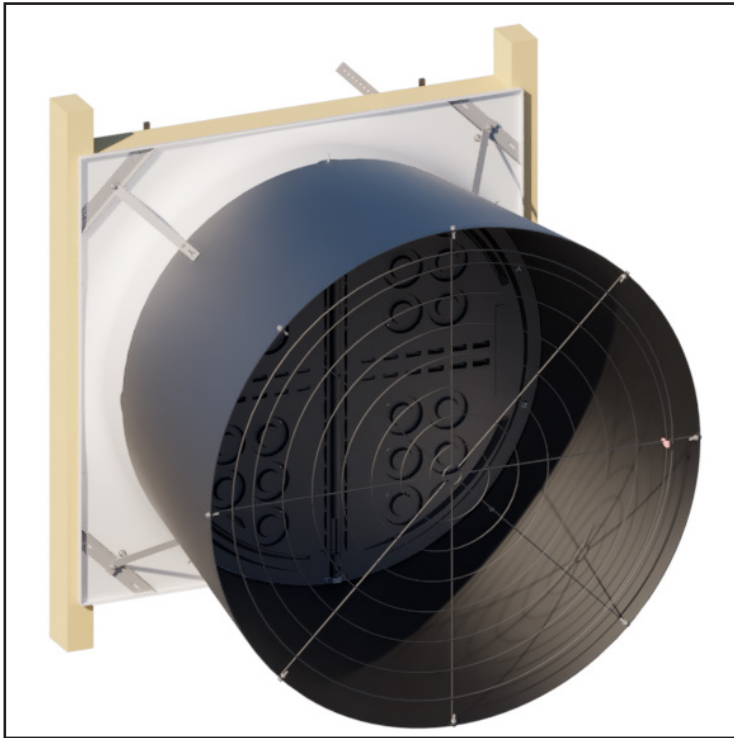

WM54K
Wall Mount Fan
with Damper Door
1-Pack Quick Kit

WM Fiberglass Wall Mount Fan

with Damper Door - 1-Pack Quick Kit

Models: WM54xKxCB



WM54K Fiberglass Wall Mount Fan with Damper

Instructions for Use and Maintenance

Thank You:

Thank you for purchasing a Munters Wall Mount Fan with Damper. Munters equipment is designed to be the highest performing, highest quality equipment you can buy. With the proper installation and maintenance it will provide many years of service.

Please Note:

To achieve maximum performance and insure long life from your Munters product it is essential that it be installed and maintained properly. Please read all instructions carefully before beginning installation.

Warranty:

For Warranty claims information see the "Warranty Claims and Return Policy" form QM1021 available from the [Munters Corporation office at 1-800-227-2376 or by e-mail at aghort.info@munters.com](mailto:aghort.info@munters.com).

Conditions and Limitations:

- Products and Systems involved in a warranty claim under the "Warranty Claims and Return Policy" shall have been properly installed, maintained and operated under competent supervision, according to the instructions provided by Munters Corporation.
- Malfunction or failure resulting from misuse, abuse, negligence, alteration, accident or lack of proper installation or maintenance shall not be considered a defect under the Warranty.

Index

Chapters	Page
1. Unpacking the Equipment	4
1.1 Parts List	4
1.2 Fan Dimensions	6
1.3 Tools for Installation	6
2. Installation Instructions	7
2.1 Wall Framing	7
2.2 Fan Assembly	8
2.3 Motor Mounting	10
2.4 Cone Installation	16
3. Electrical Wiring	22
3.1 Recommended Wiring	23
4. Operation	24
5. Maintenance	25
6. Winterizing	27
6.1 Winterizing	27
6.2 Winter Weather Protection	27
7. Troubleshooting	28
8. Exploded View and Parts List	29-31

Unpacking the Equipment

1.

1.1 Parts List

Each Crate Includes

- 1 - 54" Orifice Panel, Fiberglass Fan, Sub-Assembly
- 1 - Motor
- 1 - Drip Shield, AL
- 4 - Cone Sections, PL
- 1 - Cone Guard
- 1 - Inlet Guard
- 4 - Cone/Strut Mounting Brackets, Galvanized
- 1 - Motor Mount Stiffener Bracket, Galvanized
- 1 - Bulk Parts Package (BK1151)

BK1151 - Bulk Parts Package for WM54K

- 1 - Motor Base Bracket, CTD-GZ
- 1 - Belt Tensioner Bracket, CTD-GZ
- 1 - Motor Sheave
- 1 - V-Belt, A-Section
- 1 - 3" Idler Pulley, A-Section C.I., Blue
- 1 - Rotary Tensioner Arm, AL
- 1 - Hardware Package (HP1177)
- 1 - Coated Cable with Ferrule, 100"L.

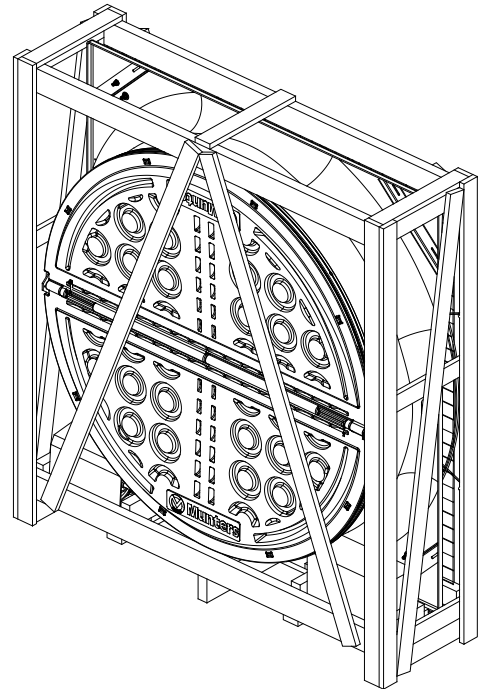

HP1177 - Hardware Package for 1 - WM54K

ID	Qty.	Cat. No.	Description
[A]	2	KW3011	5/16" x 1 1/4" O.D. Flat Washer, SS
[B]	1	KS1931	M10-1.5 x 25mm Hex Bolt, ZP
[C]	1	KW3509	10mm Splitlock Washer, ZP
[D]	16	KS1007	5/16" x 1.25" Hex Head Bolts, SS
[E]	4	KS1029	5/16" x 1.75" Hex Head Bolts, SS
[F]	3	KS1075	5/16" x 2.75" Hex Head Bolts, SS
[G]	31	KN0704	5/16" SRTD Flange Nuts, SS
[H]	1	KS2463	1/4" x 1.5" HEX Lag Screw, ZP
[J]	1	AC0211 & AC0212	Azuma Bolt & Nut, Blue PL
[K]	1	KS1046	M10-1.5 x 50mm Hex bolt, ZP
[L]	8	FH1968	1-Hole Pivoting Shutter Clip, BLK PL
[M]	2	AC1381	1/8" Dia. Cable Clamp, ZP
[N]	2	KX1158	Hole Plug, 0.73"-0.76" Dia., BLK PL

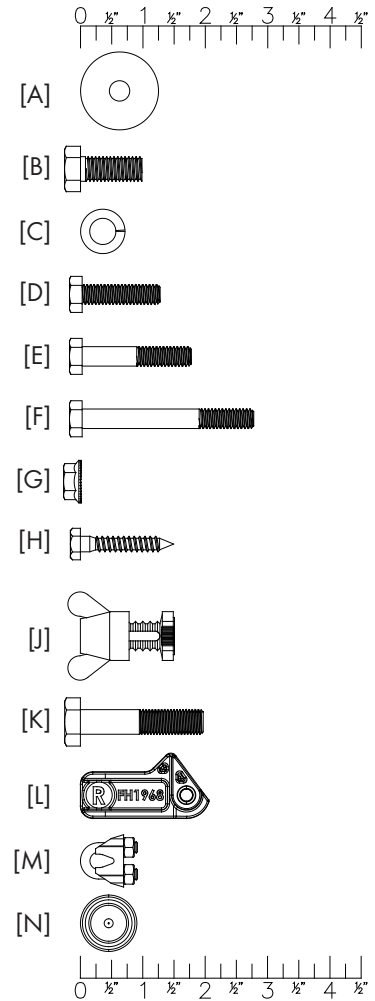

1.2 Fan Dimensions

Fan Specifications: 60Hz shown (50Hz available)

Power: 115/230 VAC* or 208-230/460 VAC

Phase: 1 or 3

*Available voltages vary depending on HP

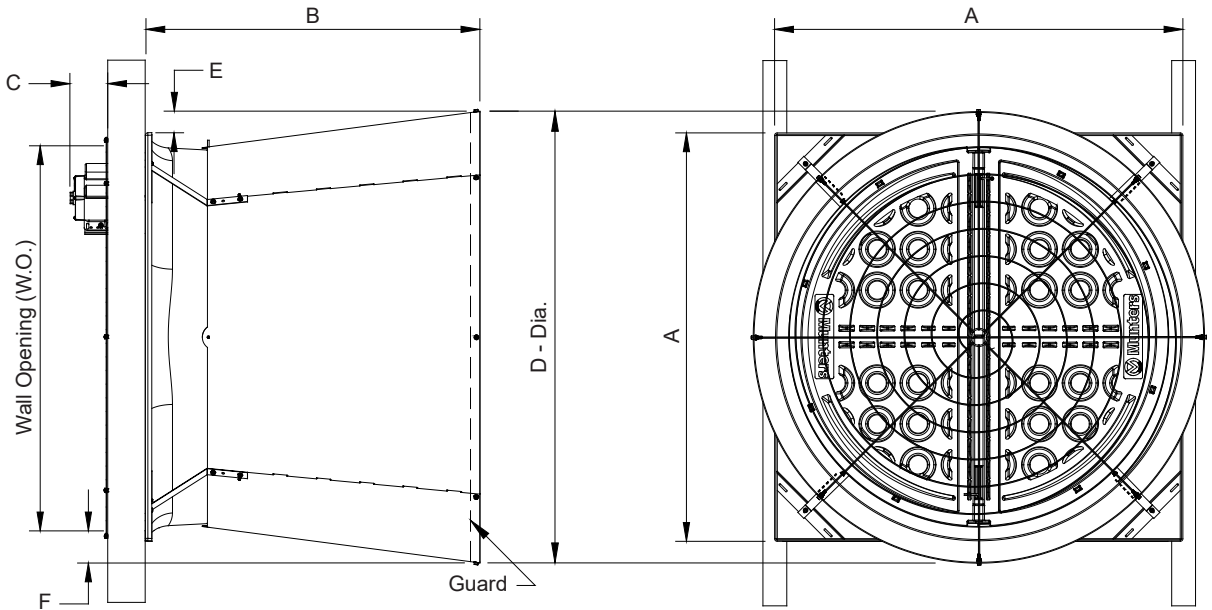

Dimensions:

Size	A	B	C*	D - Dia.	E	F	Wall Openings
54"	60"W. x 60" H.	49"	6½"	66⅝"	3⅜"	4¾"	56½"W. x 56½"H.

*Dimension varies depending on wall construction and motor configuration.

1.3 TOOLS REQUIRED FOR INSTALLATION

- 10mm [$\frac{3}{8}$ "] Socket
- 13mm [$\frac{1}{2}$ "] Socket
- 17mm [$1\frac{1}{16}$ "] Socket or Wrench
- 27mm [$1\frac{1}{16}$ "] Wrench
- $\frac{3}{8}$ " Socket
- Phillips Screwdriver, #3 Size
- $\frac{5}{32}$ " Hex Wrench
- Wire Cutting Pliers

Installation Instructions

2.

2.1 Wall Framing

Step 1

Construct framed opening to correct size according to the Wall Opening listed in Chart A below. See Figure 1A and 1B. When installing exterior sheet metal before fan, leave 2" of the framing exposed on all sides so the orifice can mount flush to the frame.

Chart A

Fan Dia.	Wall Opening (W. x H.)	Minimum Spacing 'Z'	Center To Center Dimension
54"	56½" W. x 56½" H.	12" recommended; 3½" minimum	60" Minimum

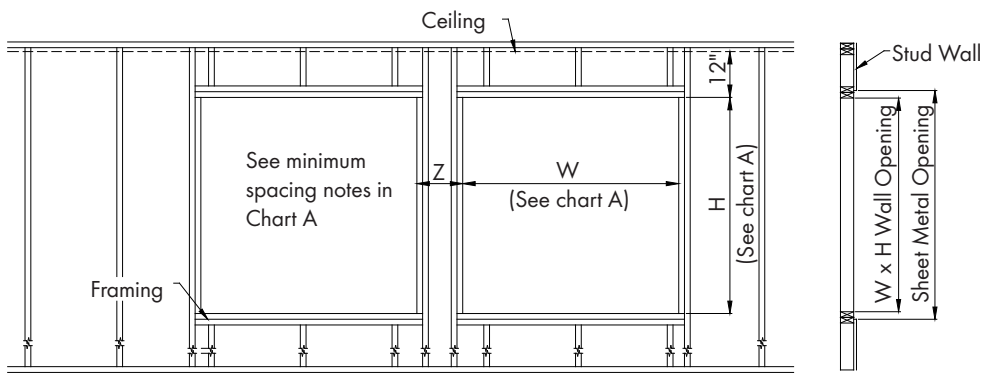

Figure 1A Frame Construction

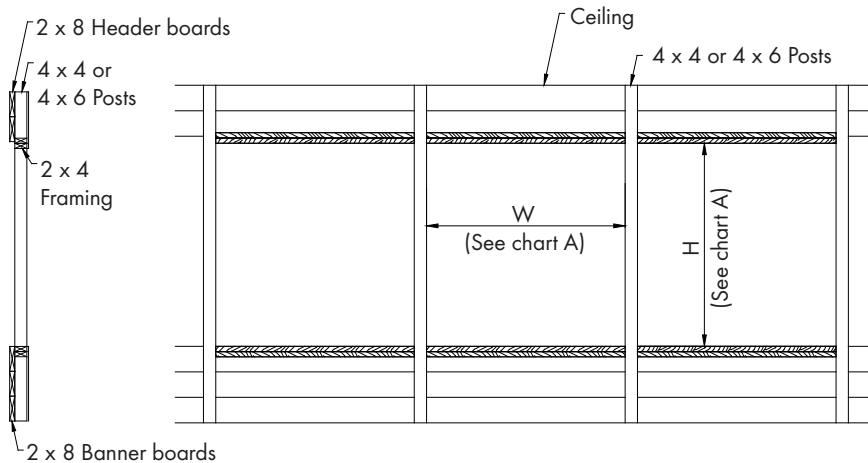
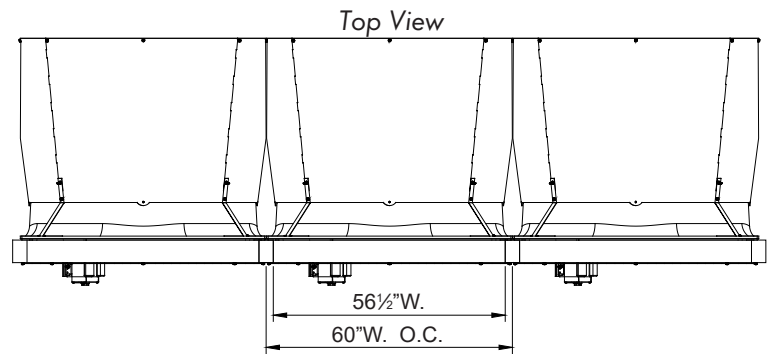
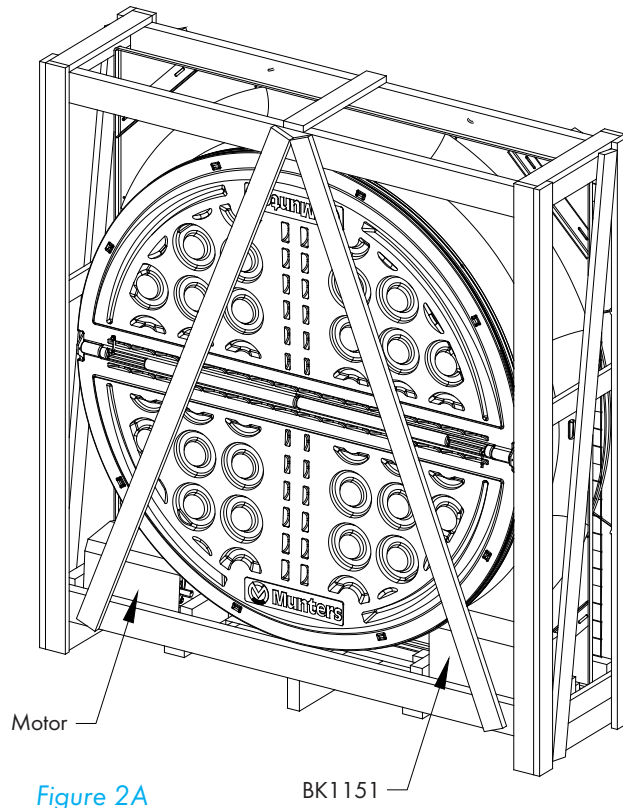

Figure 1B 4 x 4 Post Construction - Elevation View

2.2 Fan Assembly

Step 2A

Remove the BK1151 and Motor from the front of the crate. See Figure 2A.



Step 2B

Remove all the other loose parts from the back of the crate. See Figure 2B.

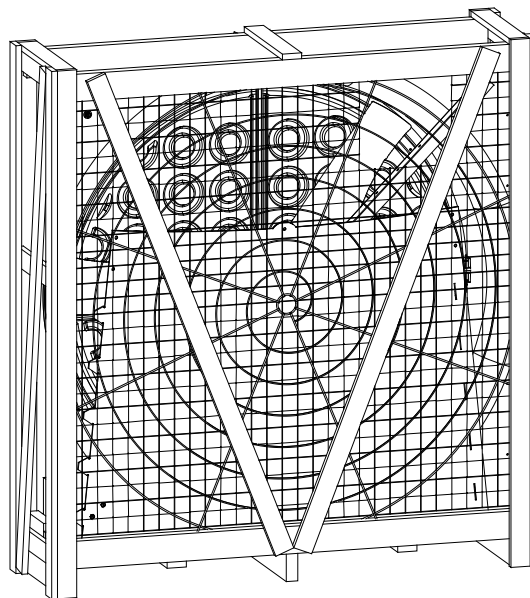

The fan can either be installed on the wall before the drive system is installed or the drive system can be installed while the fan is in the crate.

Step 3

Carefully turn the crate onto its side, so that the drain holes in the orifice are at the bottom. See Figure 3.

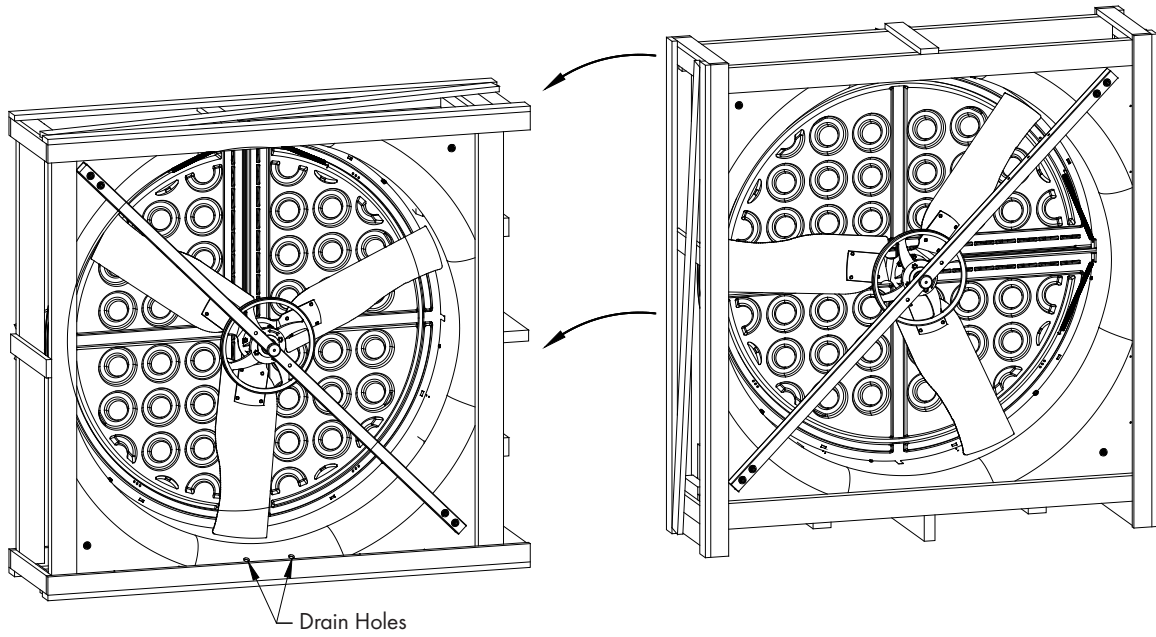

Figure 3

Step 4

Attach the Motor Base Bracket and the Belt Tensioner Bracket to the Tube Strut using (3) Long Bolts [F], (2) Washers [A] and (3) Nuts [G]. See Figure 4.

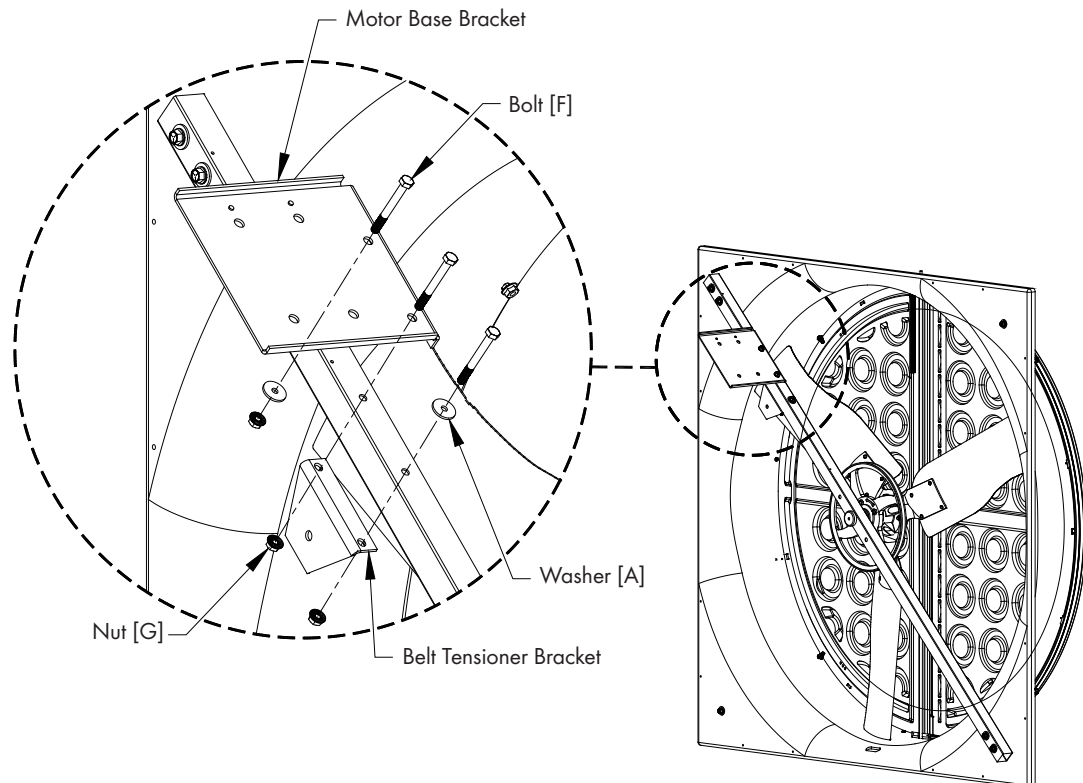

Figure 4

Step 5

Attach the 3" Idler Pulley to the Tensioner Arm using Bolt [K]. Then attach the Tensioner/Pulley Assembly to the Tensioner Bracket using Bolt [B] and Splitlock Washer [C]. Finger tighten only at this time. See Figure 5.

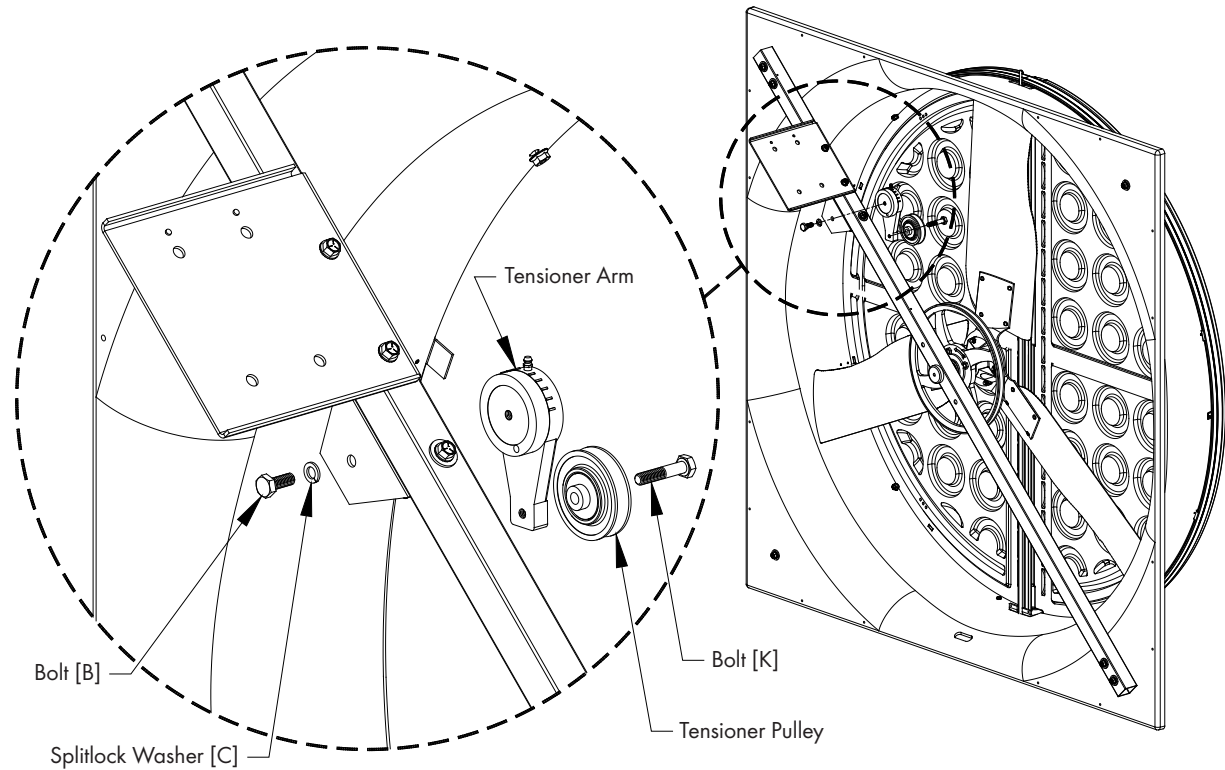
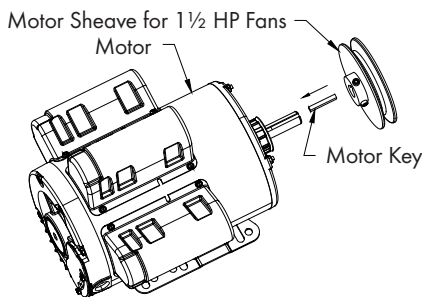

Figure 5

2.3 Motor Mounting

Step 6

Find the Key provided with the Motor and place it in the Keyway on the motor shaft. Place the Motor Sheave on the Motor shaft with the hub facing towards the motor. See Figure 6. ONLY tighten the set screw(s) enough to hold the Sheave in place at this time. The Motor Sheave for 1 HP fans will have one set screw and the Motor Sheave for 1 1/2 HP fans will have two set screws.



1 1/2 HP Motor with 2 Set Screw Sheave

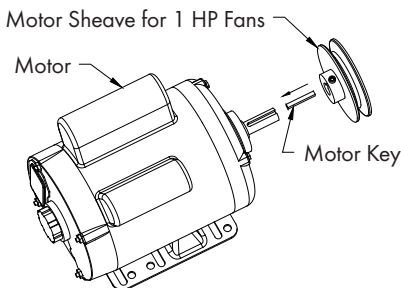

1 HP Motor with 1 Set Screw Sheave

Note:

When wiring motor, check rotation of propeller. Internal wiring of motor may need to be changed to assure proper rotation of propeller.

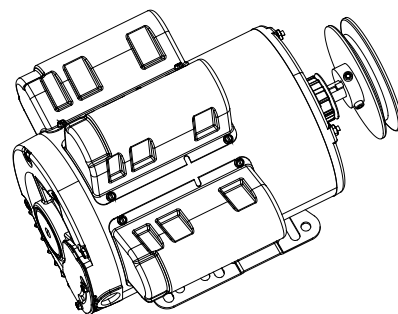

1 1/2 HP Motor with 2 Set Screw Sheave

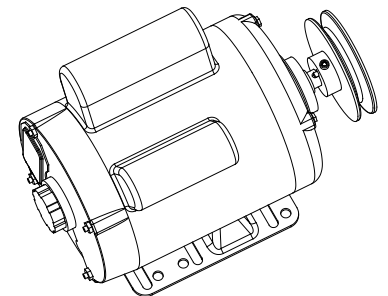

1 HP Motor with 1 Set Screw Sheave

Figure 6

Step 7

Set Motor on Motor Bracket so Motor base rests against lower Motor Bracket flange. Align middle and front slots in Motor base with holes in Motor Bracket. See Figure 7.

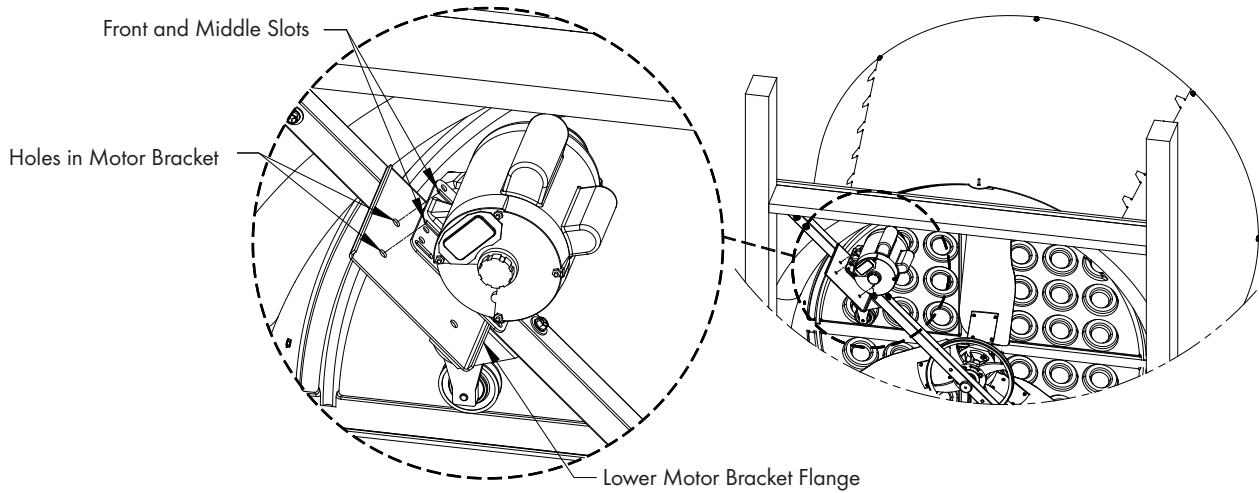

Figure 7

Step 8A

Secure Motor to Motor Bracket and Motor Bracket Stiffener using (4) Short Bolts [D] and Nuts [G]. The rear upper bolt is where Motor Bracket Stiffener is attached. See Figure 8A.

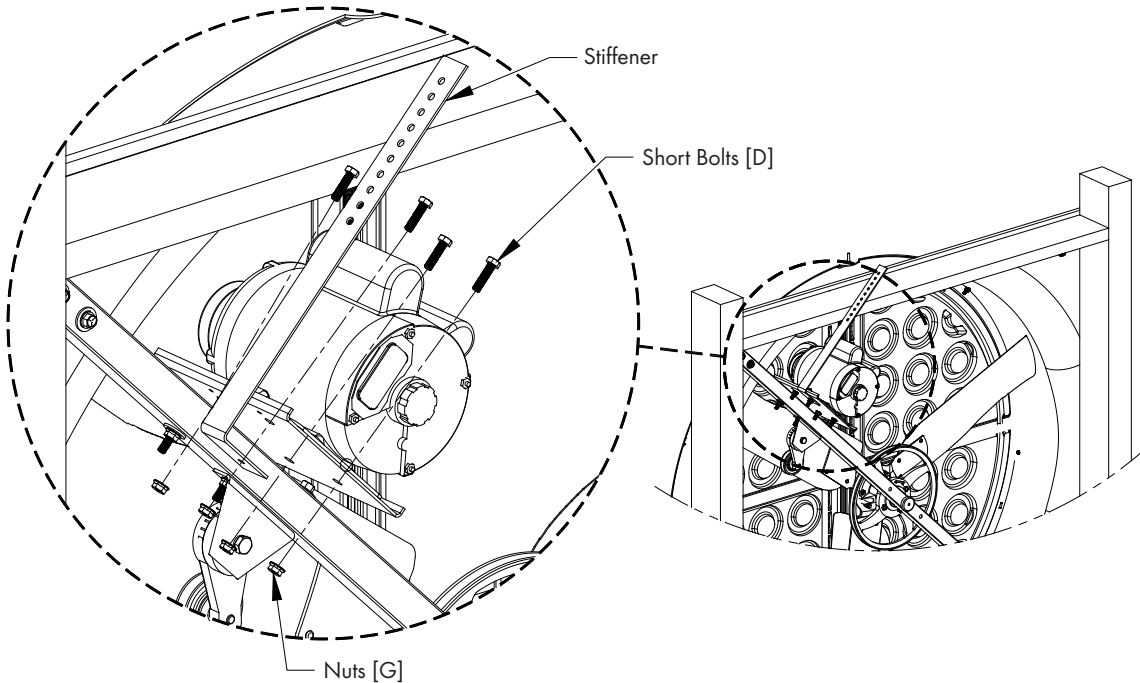

Figure 8A

Step 8B

Using channel locks and/or a hammer twist the Motor Bracket Stiffener so that the holes in the bracket lay flat against the framing. Then secure the bracket to the framing using (1) Lag Screw [H]. See Figure 8B.

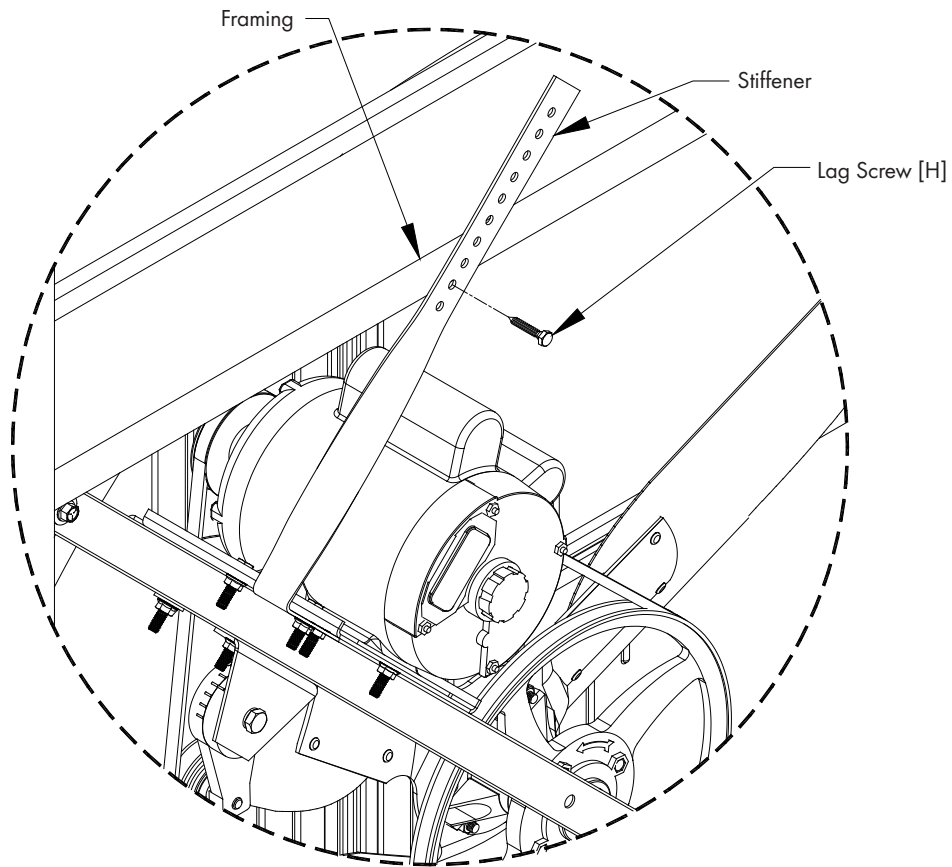
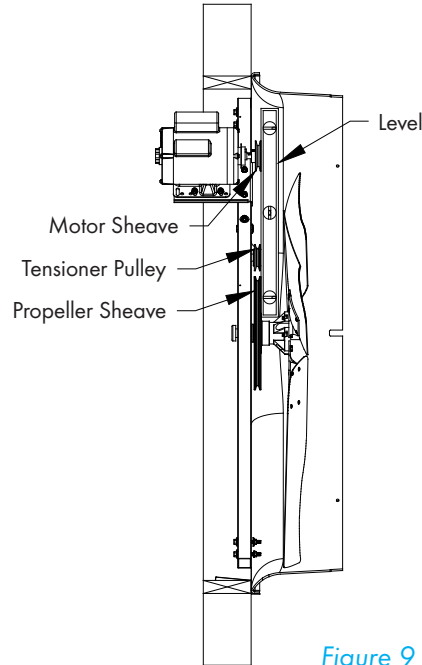

Figure 8B

Step 9

Use a straight edge or level to check alignment of Propeller Sheave, Tensioner Pulley and Motor Sheave. If needed, adjust position of Motor Sheave so the 3 pulleys line up. Once Motor Sheave is aligned tighten the set screw(s) to 150 in-lbs [17 N-m] torque. See Figure 9. The Motor Sheave for 1 HP fans will have one set screw and the Motor Sheave for 1½ HP fans will have two set screws.

**NOTE:**

Motor Sheave set screws must be tightened to proper torque at this time. Failure to do so will result in damage to fan and will not be covered under warranty.

Figure 9

Step 10A

Slide V-belt over Propeller and install by wrapping it around 2 smaller pulleys and starting it over larger Sheave. Continue rolling it onto the larger Sheave until it fits into groove. See Figure 10A.

If desired the 2 drain holes in the Orifice Panel can be plugged using (2) Hole Plugs [NN].

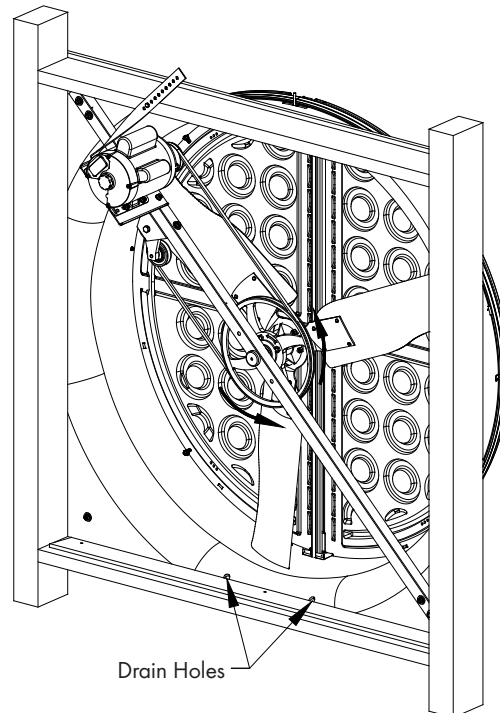

Figure 10A

Step 10B

To adjust belt tensioner to proper setting, loosen 10mm bolt (using 17mm end wrench) to allow tensioner arm to rotate. Working from inlet/motor side of fan, place a 27mm (1 1/16") wrench onto the hex on the tensioner. Turn wrench clockwise until the single mark on base of belt tensioner is aligned with Mark 2 on tensioner arm. Hold at this setting and tighten the 10mm bolt to 40 ft.lbs. [54 N-m] torque. See Figure 10B.

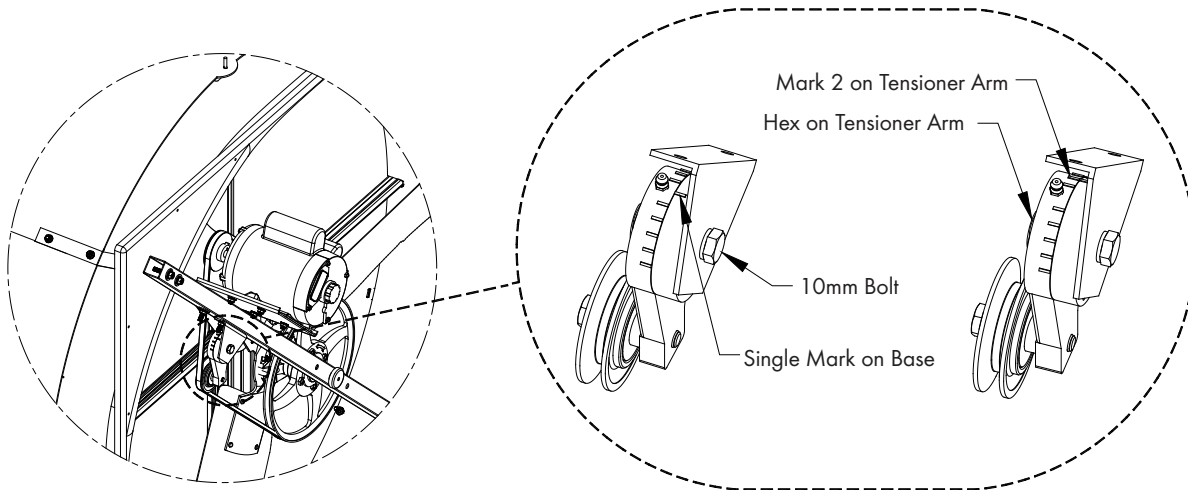

Figure 10B

Step 11A

Attach Drip Shield to bottom of framed opening using (3) Barn Screws (Not Provided). See Figure 11A and 11B. If a 4" wall is used a support board must be installed as shown in Figure 11B. Be sure not to deform Drip Shield when installing screws.

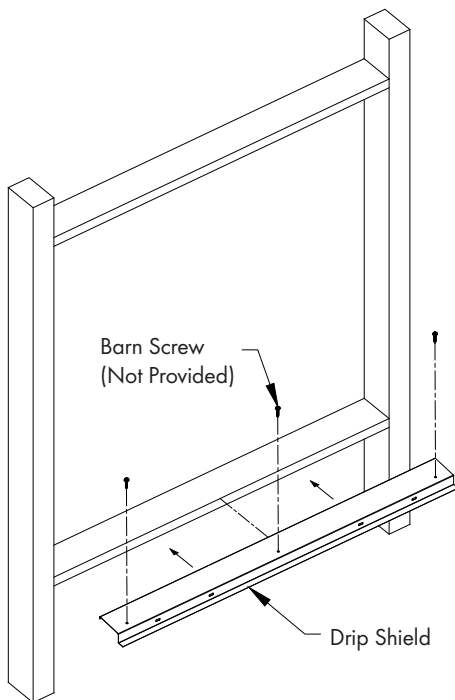

Figure 11A

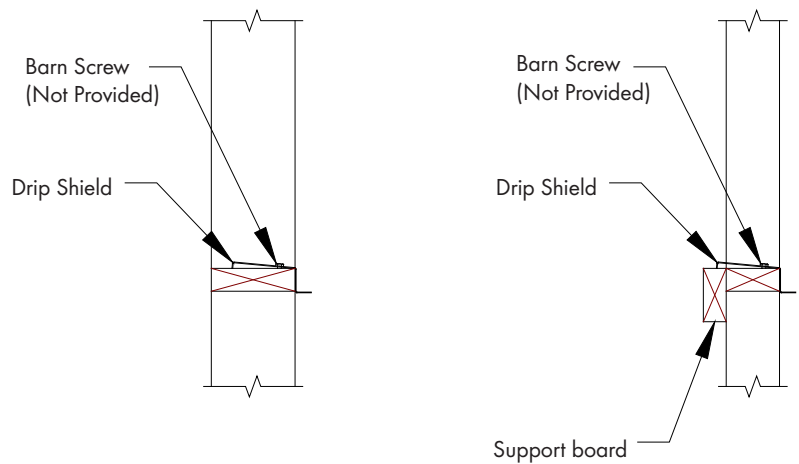

Figure 11B

Step 12

Locate Drain hole in Orifice Panel. This is bottom of Fan. Set bottom edge of fan on Drip Shield ledge and center panel on opening. Secure Fan to wall using (16) Barn Screws (Not Provided).

See Figure 12A and 12B.

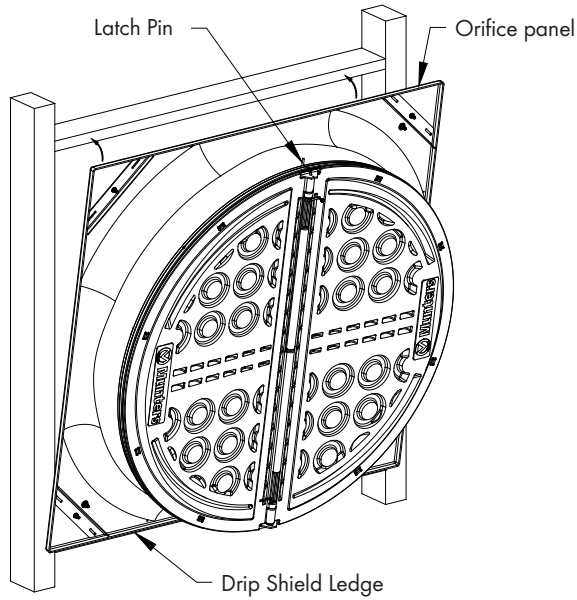

Figure 12A

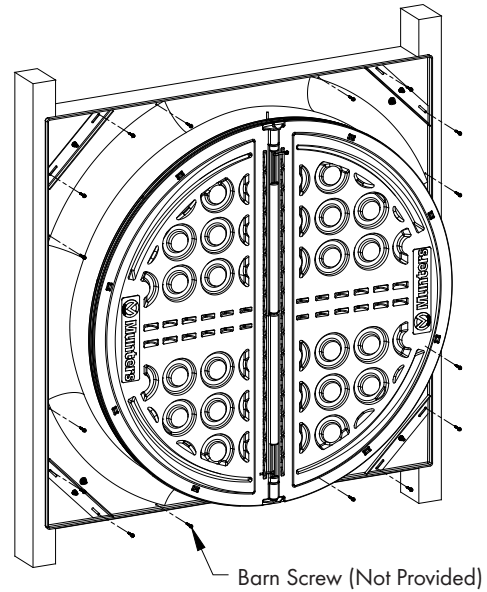

Figure 12B

Step 13

Find Coated Cable and insert end opposite ferrule into small hole in upper plate of Main Frame. Pull it through until ferrule stops at plate. See Figure 13.

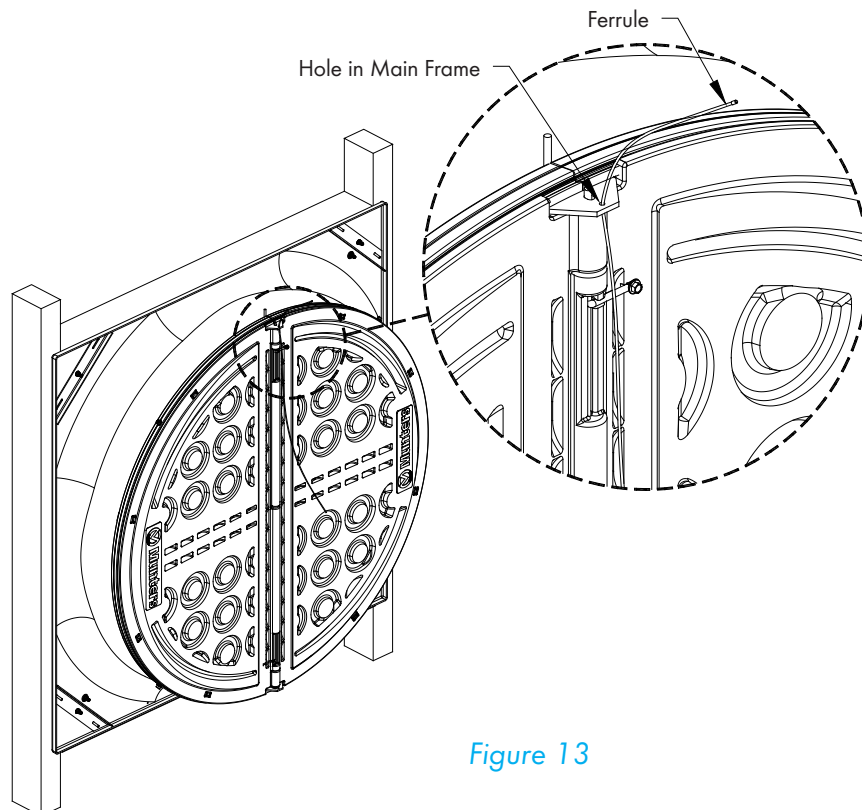

Figure 13

2.4 Cone Installation

Step 14

Place all 4 cone sections on a flat surface with tabs from one facing slots of the next. [See Figure 14A.](#) Curl up tab end of first cone section and insert tabs up into slots in the next cone section. A mallet may be needed to seat slots over tabs completely. [See Figure 14B.](#) Repeat this until all 4 cone sections are connected and laying flat.

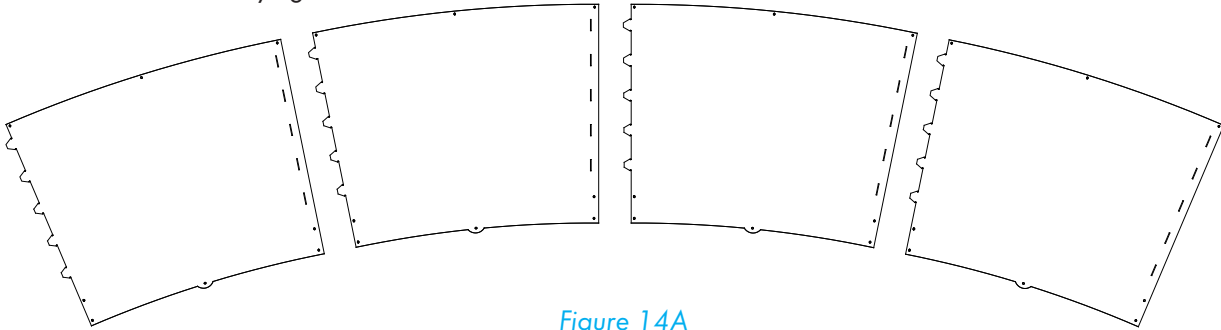

Figure 14A

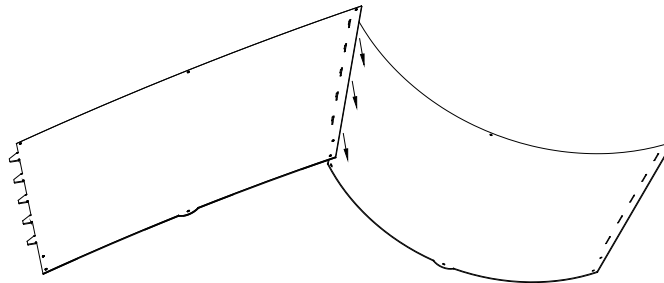

Figure 14B

Step 15A

Fasten each of the joints in the single outer hole using (1) Short Bolt [D] and Nut [G], with the nut on the side with the tabs. At the inner pair of holes of each joint attach (1) Cone Support Bracket to the inner hole using (1) Short Bolt [D] and Nut [G] with the bolt head on the side with the tabs. [See Figure 15A.](#)

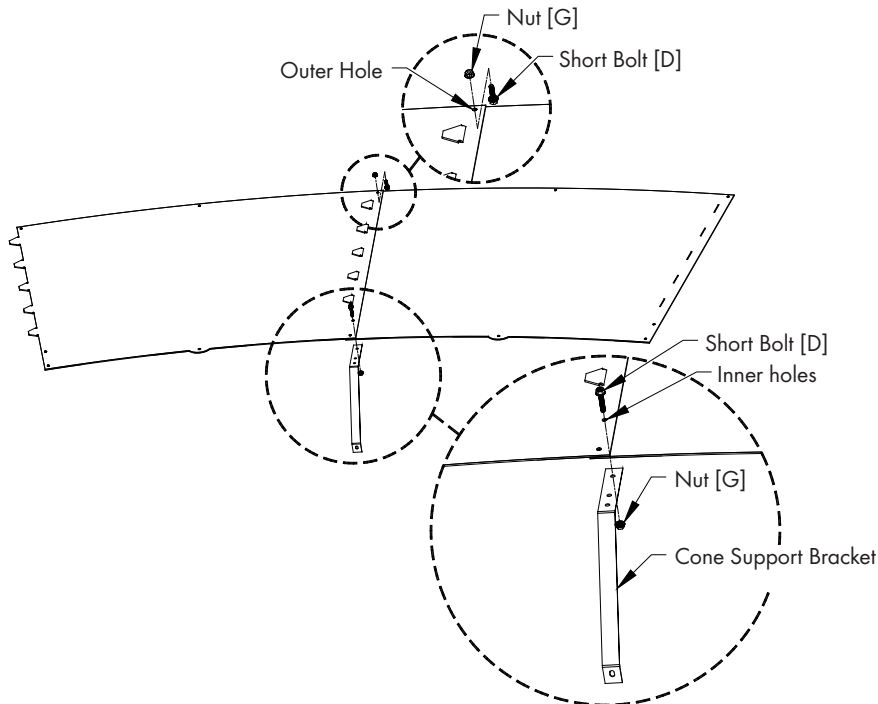

Figure 15A

Step 15B

Stand cone sections on end and curl ends around to form cone with Cone Support Bracket on outside and tabs on inside. Insert remaining tabs into slots so tabs are inside cone and fasten final joint using (1) Short Bolt [D] and Nut [G], with nut on inside of cone. At the inner pair of holes attach (1) Cone Support Bracket to the inner hole using (1) Short Bolt [D] and Nut [G] with bolt head on inside of cone. See [Figure 15B](#).

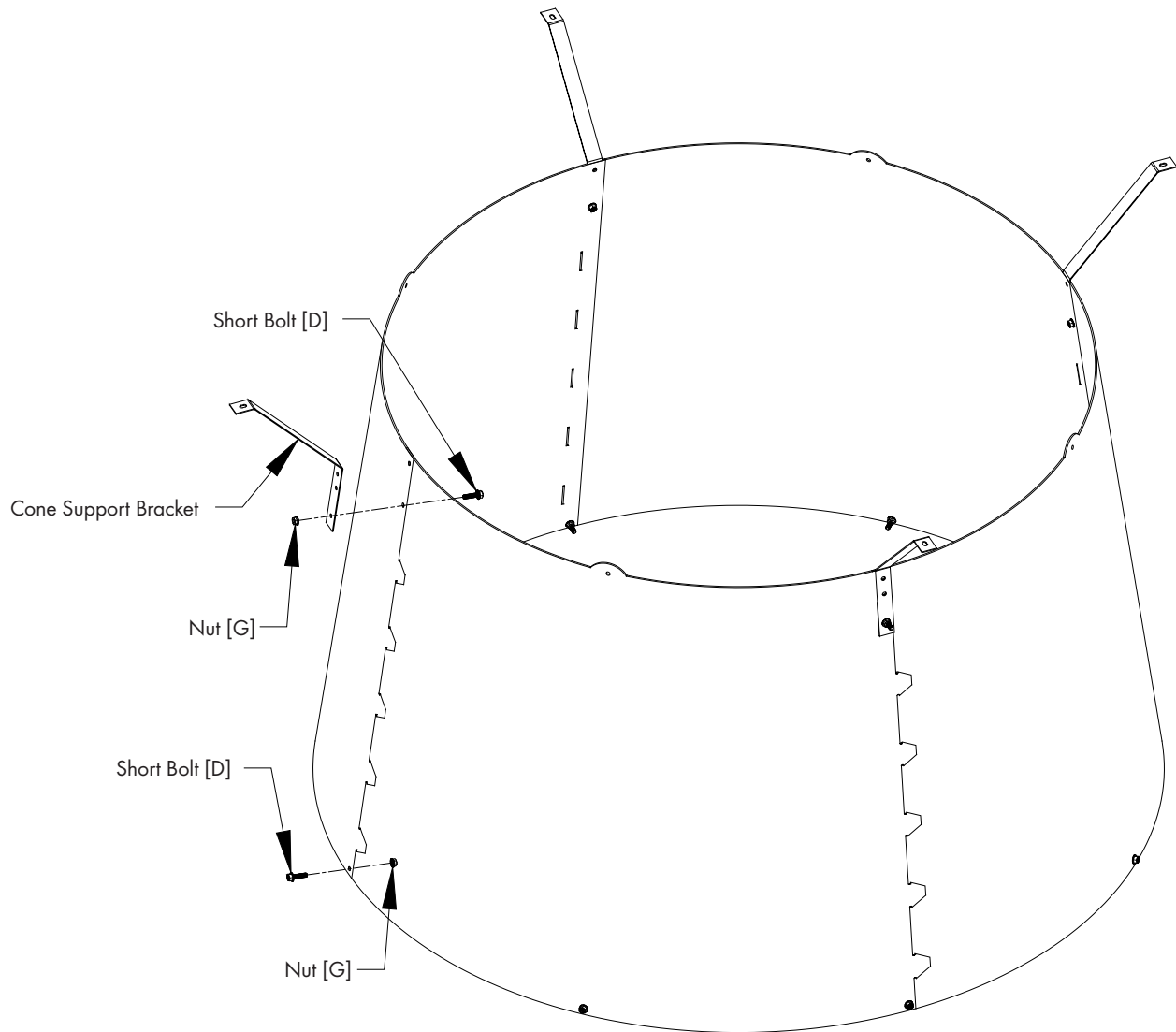

Figure 15B

Step 16A

Install cone onto fan by putting top of cone over top of fan. The hole in tab of one cone section should slide down over the Frame Pin in the Main Frame assembly. Allow remainder of cone to slide over orifice panel making sure Cone Support Brackets remain on outside of cone. See Figure 16A.

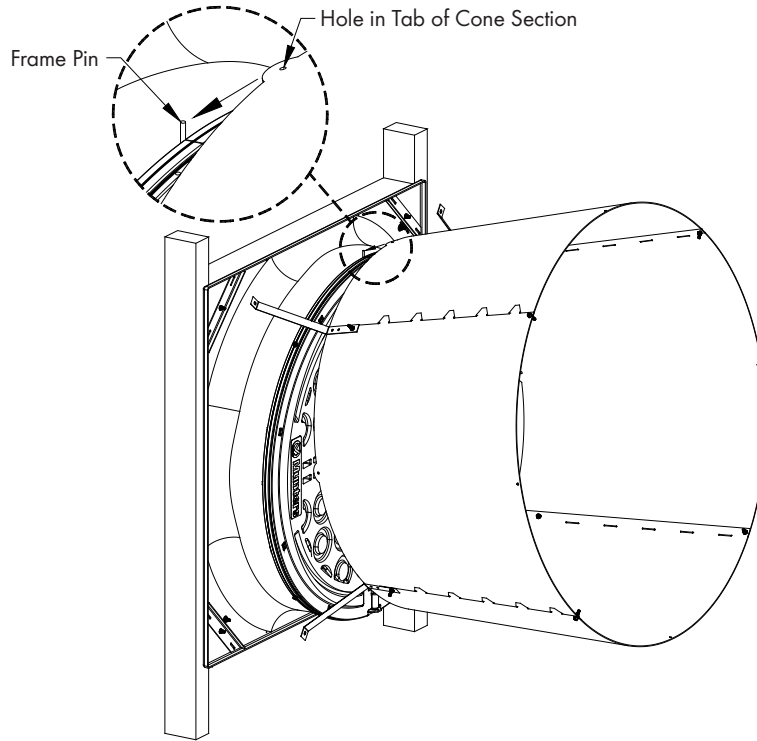

Figure 16A

Step 16B

Place end of Cone Support Bracket with slot over bolt holding Cone/Strut Mounting Bracket to the orifice and secure with Nut [G]. See Figure 16B. Secure Cone to Fan installing Medium Bolt [E] through the remaining hole in the Cone Support Bracket and fastening with Nut [G]. A long screwdriver may be needed to help align the holes through Cone Support Bracket, Cone, Main Frame and Orifice. Repeat process for all 4 Cone Support Brackets. See Figure 16B.

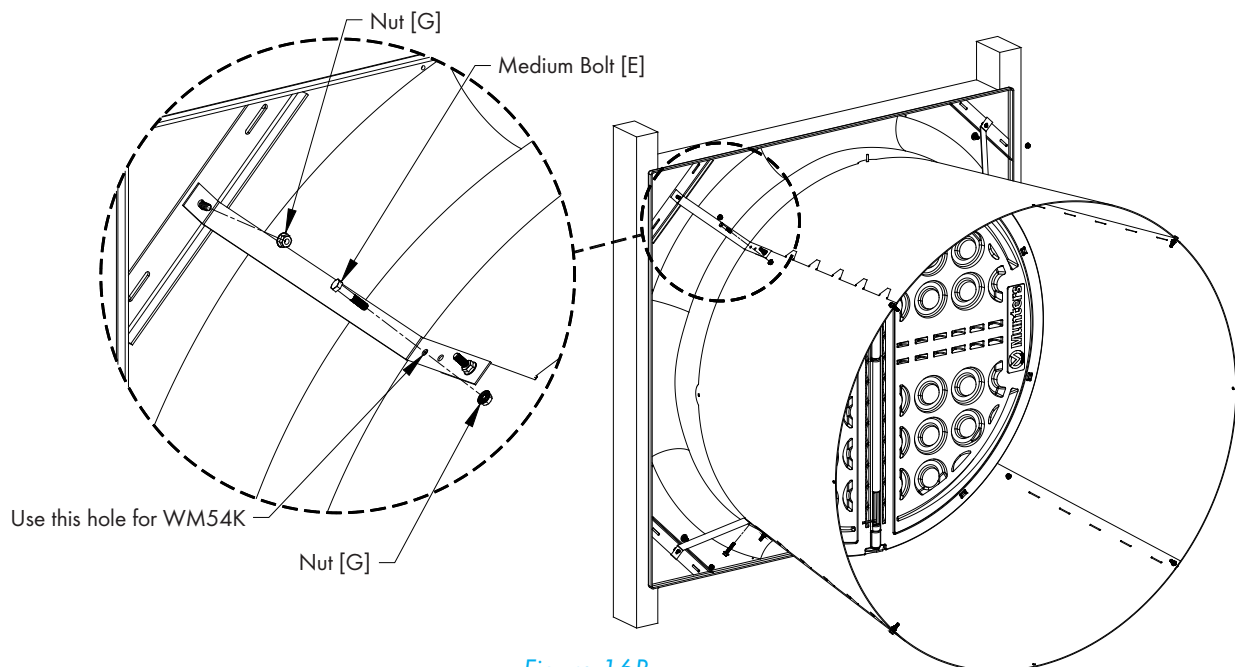

Figure 16B

Step 17

Insert guard into cone with the eyelets facing you. Install eyelets over bolts already installed in cone and fasten with Nut [G]. Secure remaining eyelets using Short Bolt [D] and Nut [G]. See Figure 17.

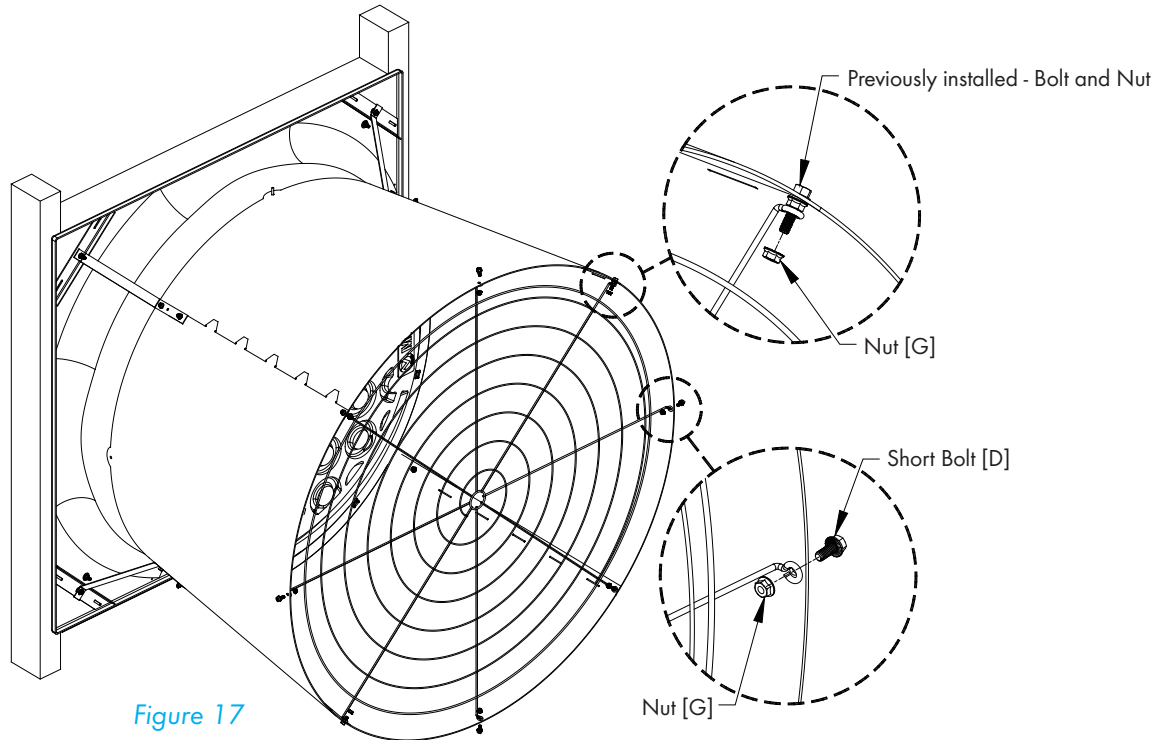

Figure 17

Step 18

Loop Coated Cable that was installed in a previous step, around the lower, middle joint in guard and fasten to itself with Azuma Bolt & Nut [J]. Make sure cable is pulled snug. See Figure 18.

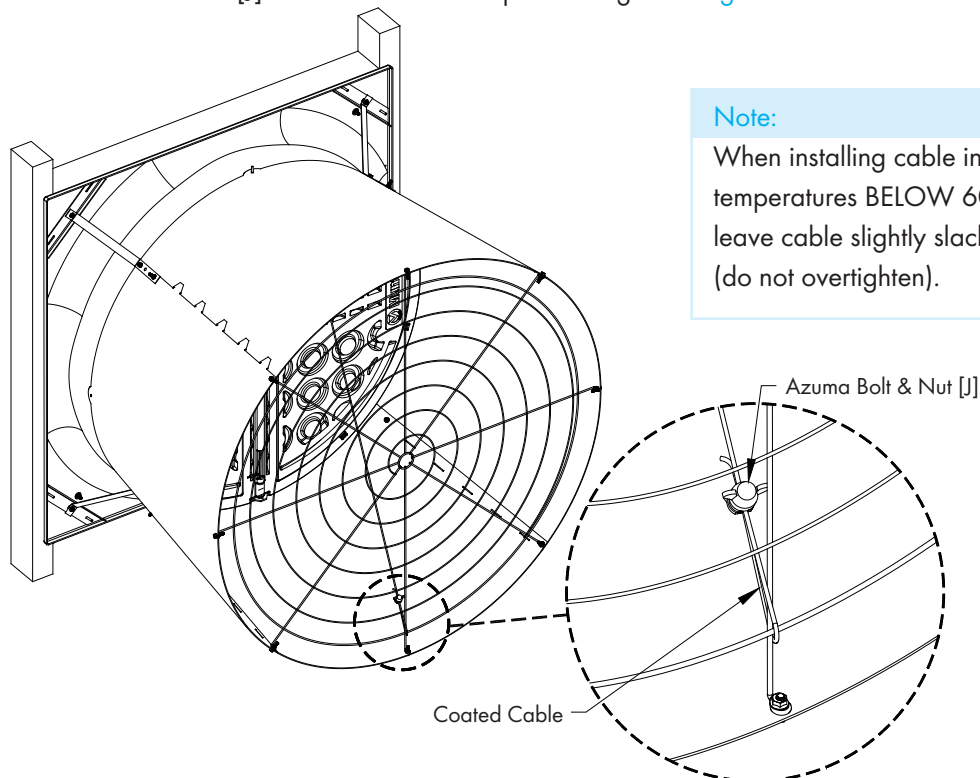

Figure 18

Step 19

If Fans are to be installed 60" O.C., cut the 3 o'clock and 9 o'clock guard wire in the position shown. Push the side of the cone in as far as possible and fasten the cut guard wire to the attached guard wire using Clamp [M]. See Figure 19.

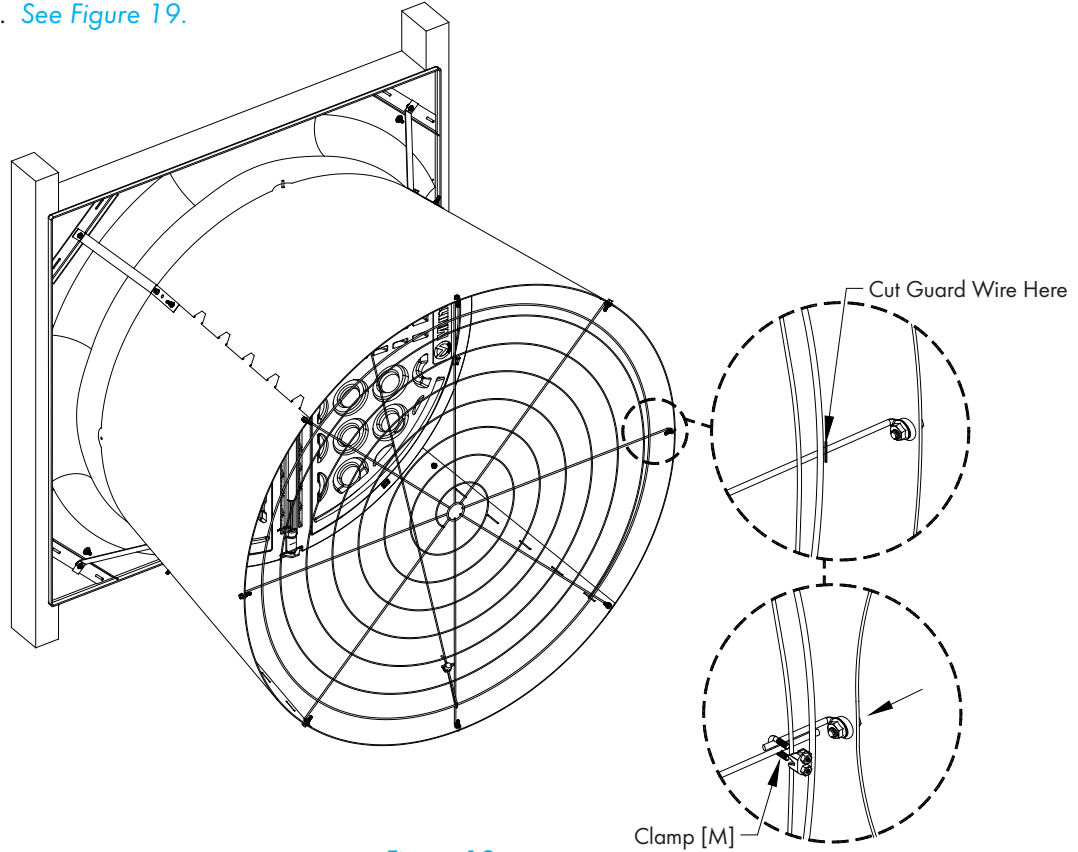

Figure 19

Step 20A

Cut a section of the inlet guard out to fit over the motor as shown below for the appropriate fan. When cutting the guard wires make sure to cut them as close to the other wires as possible. See Figure 20A.

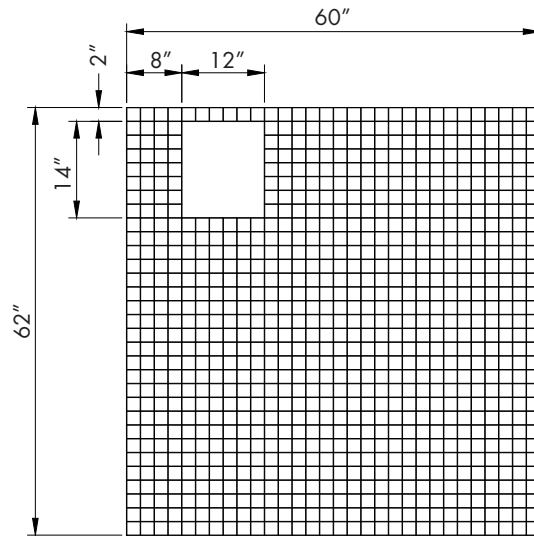

Figure 20A

Step 20B

Place guard against framing and fasten guard in place using (8) Shutter Clips [L] and Barn Screws (not provided), 2 per side. See Figure 20B.

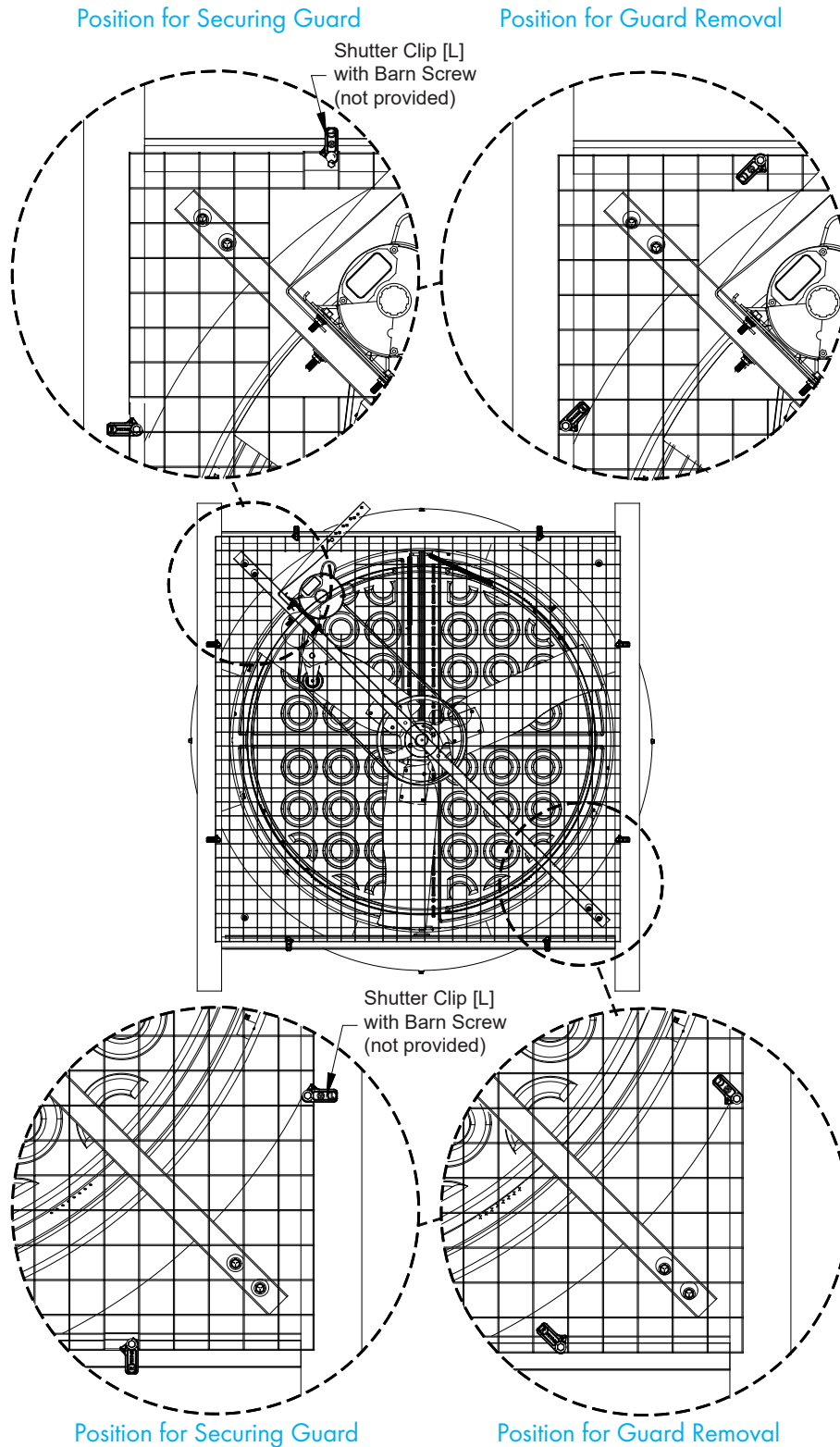

Figure 20B

All wiring should be installed in accordance with National, State, and Local electrical codes. Fans used to ventilate livestock buildings or other rooms where continuous air movement is essential should be connected to individual electrical circuits, with a minimum of two circuits per room. For electrical connection requirements, refer to diagram on motor nameplate and to information enclosed with the Munters environmental control to be used.

Single Phase Fans: motor overload protection should be provided for each fan. A Circuit Breaker Switch or slow blow motor type fuses must be used, *See Figure 21A. See form QM1400 for proper size.*

Three Phase Fans: motor overload protection should be provided for each fan. A three-pole motor starter or slow blow motor fuses must be used. *See Figure 21B.*

If a frequency drive (inverter) is used, confirm that motors are rated for inverter duty at the voltage used. The installation of line reactors is recommended to reduce voltage spikes and harmonic distortion. Supplemental motor overload protection is also recommended.

NOTE: A safety cut-off switch should be located adjacent to each fan.

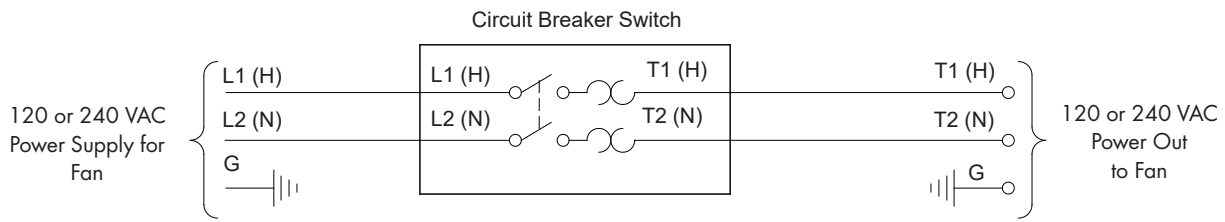

Figure 21A
Single Phase - Motor Overload Protection with Disconnect
(SY2000 or Equivalent)

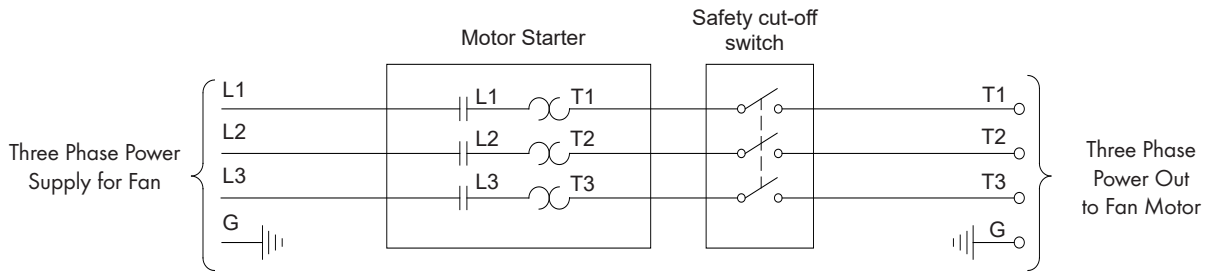

Figure 21B
Three Phase - Motor Overload Protection with Disconnect

KEY:
L1=Line 1
L2=Line 2
L3=Line 3
H=Hot
N=Neutral
G=Ground

NOTE: Information in parenthesis refers to 120 VAC control.

3.1 Recommended Wiring

Step 1

As the power cable exits the back of the motor form a drip loop and then run cable to power source.

See [Figure 22A](#) and [22B](#).

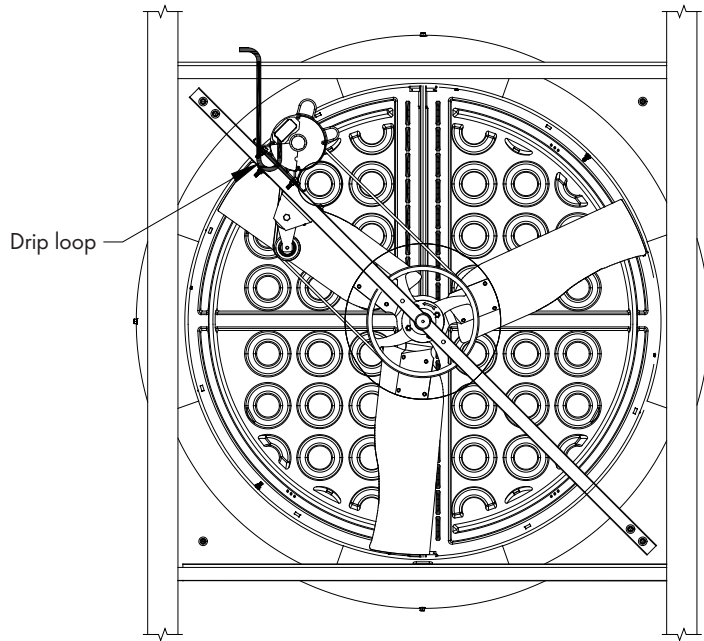

Figure 22A

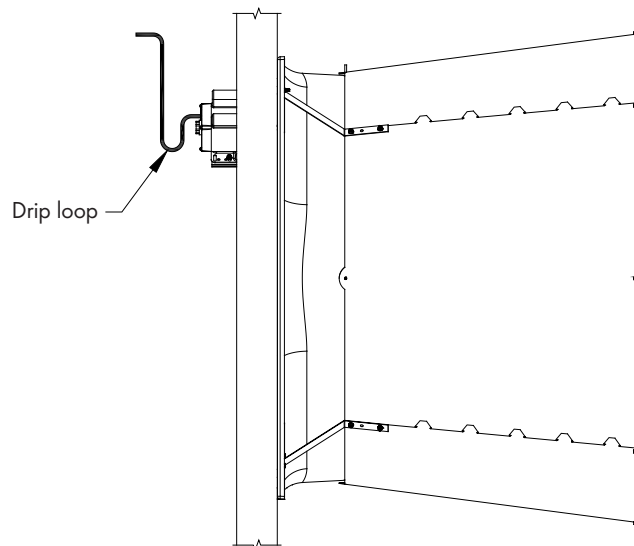

Figure 22B

4. Operation

- 1) **INITIAL START-UP:** With electrical power off, verify that fan propeller turns freely and that all fasteners are secure. Turn on electrical power and confirm that fan operates smoothly.
- 2) **ADJUSTMENTS:** Set fan control to temperature shown on your Aerotech ventilation system drawing, or to a value which will provide the desired environmental conditions.

Single Phase Fans: Single phase fans are designed for single speed operation only.

Three Phase Fans: If a frequency drive is used, the minimum operating frequency is 30 Hz.



5. Maintenance

The following inspection and cleaning procedures should be performed monthly:

Tools Needed for Maintenance:

wrenches: 10mm, 13mm, 16mm, 17mm, 27mm, ½", 6mm Hex

- 1) **INSPECT PROPELLER:** Check that propeller is secure on drive hub and that there are no signs of damage. The blades are of a self-cleaning design and should not require maintenance.
- 2) **CLEAN** regularly for best results:
 - **FAN MOTOR:** Remove any dust accumulation from motor using a brush or cloth. (DO NOT use a pressure washer). A clean motor will run cooler and last longer. At the same time, verify that the motor is secure in its mount.
 - **DAMPER:** Carefully clean dust from damper doors and frame so that doors open and close freely. A brush or cloth should be used.
 - **GUARD:** Clean any dust or feathers from fan guards using a brush. Dirty guards can reduce airflow.
- 3) **CHECK FASTENERS:** For safety, all fasteners should be inspected. Tighten any loose connections.
- 4) **INSPECT FAN CONTROL:** With power disconnected, inspect all electrical connections. Wiring should be secure and in good condition. Remove any dust build-up from control case and sensor using a soft brush or cloth. **NEVER CLEAN ELECTRICAL EQUIPMENT WITH A PRESSURE WASHER!**



- 5) **CHECKING PULLEYS:** Roll the belt off and look at all pulleys. If a pulley has grooves in it or is no longer smooth, it needs replacement. A loose or slipping belt will reduce fan performance up to 60% and cause premature belt failure.

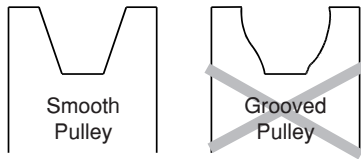

- 6) **CHECK DRIVE ALIGNMENT:** Check alignment of belt on idler pulley, it should be centered on the idler pulley. The belt tensioner idler pulley and propeller sheave are fixed in position, therefore, alignment must be obtained by adjusting the motor sheave. If an adjustment is needed, remove the belt, then loosen the set screws in the sheave and move as necessary to achieve proper alignment. Remember to tighten the sheave set screws after making an adjustment. Drive alignment is very important for long belt life and proper operation.

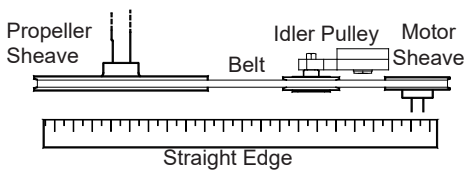

- 7) **BELT TIGHTENING:** To adjust belt tensioner to proper setting, loosen 10 mm bolt (using 17mm end wrench) to allow tensioner arm to rotate. Working from inlet/motor side of fan, place a 27 mm (1 1/16") wrench onto the hex on the tensioner. Turn wrench clockwise until the single mark on base of belt tensioner is aligned with Mark 2 on tensioner arm. Hold tensioner at this setting and tighten 10mm bolt to 40 ft.-lbs [54 N-m] torque.

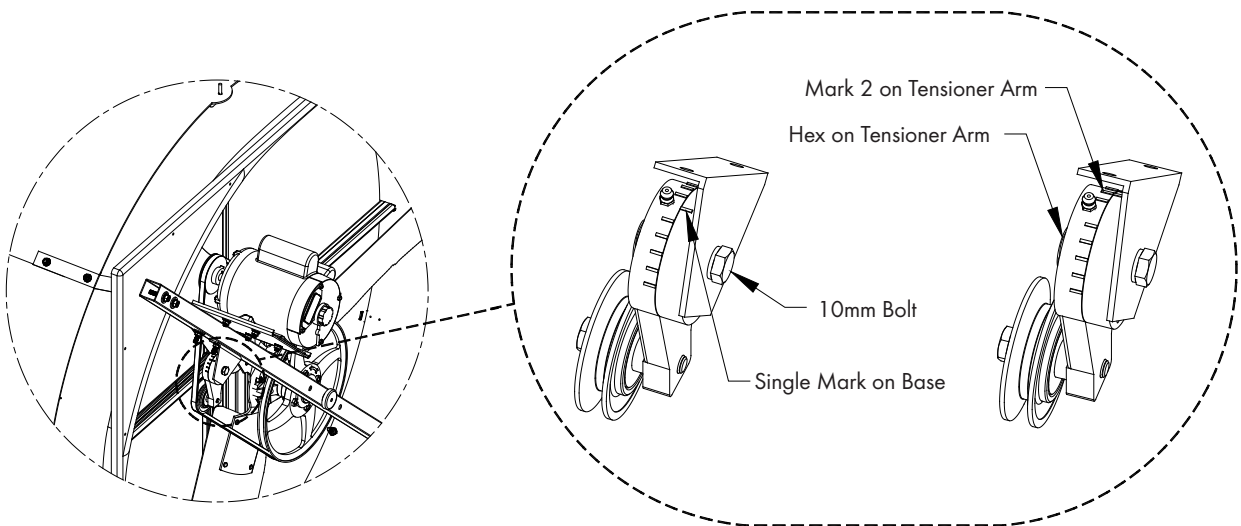

6.1 Winterizing

In most climates, it is probable that the ventilation system will never need to operate at a total capacity during the colder winter months. Consequently, it is advisable to “winterize” those fans which will not be used in cold weather to avoid unnecessary heat loss and condensation.

To winterize, turn fan control “off”. Install the insulated closure panel over the fan intake. If you don’t have an insulated closure panel, a piece of rigid insulation material can be used. Remember the insulation panel must be removed before warmer weather returns.

NOTE: At least one single speed fan should be left uncovered and with power available to provide air movement in the event of variable speed control difficulties.

6.2 Winter Weather Protection

To prevent cone or fan damage from snow or ice sliding off building roof, weather protection must be provided. A weather shelter may be constructed to cover the entire fan, [See Figure 23](#), or snow guards may be placed on the roof, [See Figure 24](#).

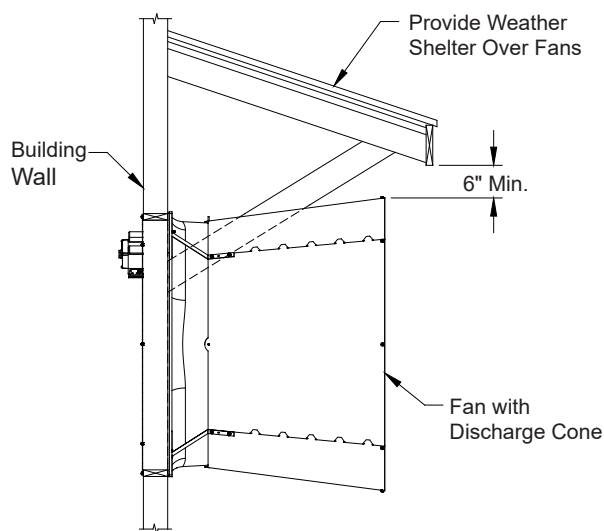

Figure 23

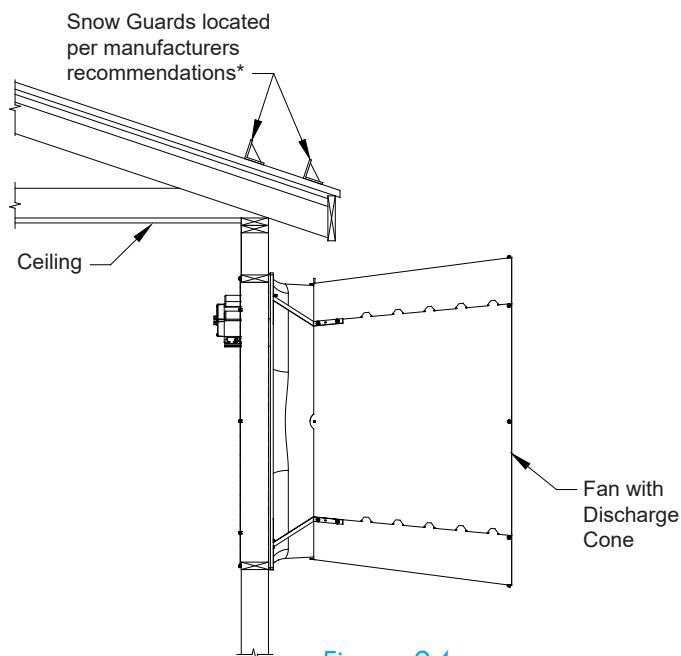

Figure 24

*Snow Guard Suppliers

Company Name	Phone No.	Fax No.	Web Site
Snojax, Inc.	800-766-5291	717-697-2452	www.snojax.com
Polar Blox	800-298-4328	814 629-9090	www.polarblox.com
LM Curbs	800-284-1412	903 759-3598	www.lmcurbs.com
Alpine Snow Guards	888-766-4273	888-766-9994	www.alpinesnowguards.com



IMPORTANT

Munters Product and System Warranties do not cover cone or fan damage from external sources.

Note: Snow guards are designed to prevent sudden, dangerous snow and ice slides when attached to the building roof according to manufacturers recommendations. The supplier listing above is given as a reference only. Munters does not endorse any specific snow guard product and no performance warranty is implied.

7.1 Troubleshooting



SYMPTOM	POSSIBLE CAUSES	CORRECTIVE ACTION
Fan Not Operating	<ol style="list-style-type: none"> 1. Fan control set above room temperature 2. Blown fuse or open circuit breaker 3. Propeller blade contacting fan housing 4. Fan control defective 5. Motor defective 	<ol style="list-style-type: none"> 1. Set to a lower temperature 2. Replace fuse or reset breaker 3. Realign propeller in fan housing 4. Repair or replace control 5. Repair or replace motor
Fan Operating- Insufficient Airflow	<ol style="list-style-type: none"> 1. Damper door jammed 2. Guard dirty 	<ol style="list-style-type: none"> 1. Clean damper door & fan housing 2. Clean guard
Excessive Noise	<ol style="list-style-type: none"> 1. Propeller blade contacting fan housing 	<ol style="list-style-type: none"> 1. Sand fan housing to remove high spot
Excessive Vibration	<ol style="list-style-type: none"> 1. Motor loose on mount 2. Propeller damaged 3. Motor or propeller shaft bent 	<ol style="list-style-type: none"> 1. Tighten fasteners 2. Replace propeller 3. Repair or replace motor or propeller shaft
Fan Never Turns Off	<ol style="list-style-type: none"> 1. Override thermostat set incorrectly 2. Control set for continuous operation 	<ol style="list-style-type: none"> 1. Set to the correct temperature 2. Set control correctly

Exploded View

8.

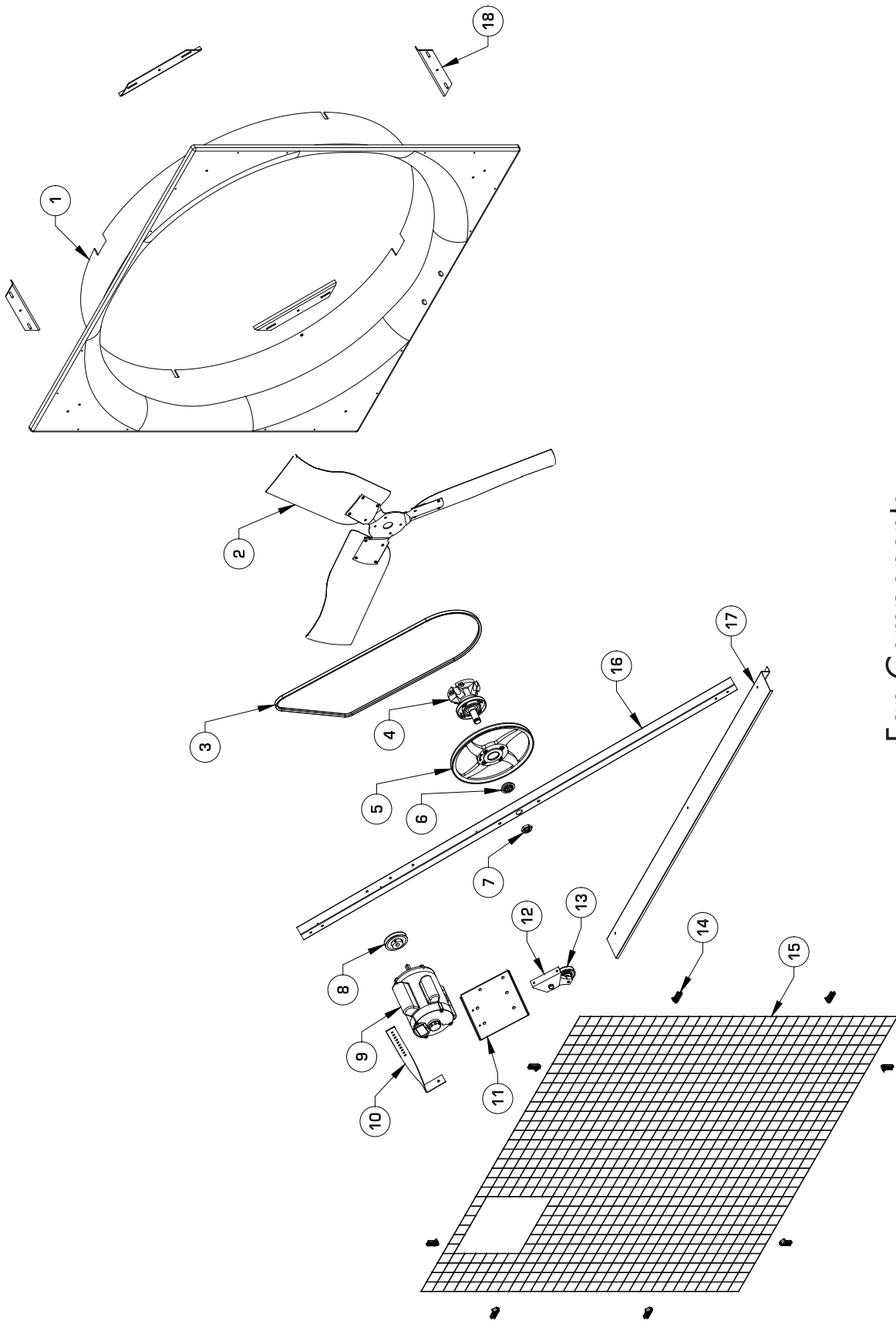

Fan Components

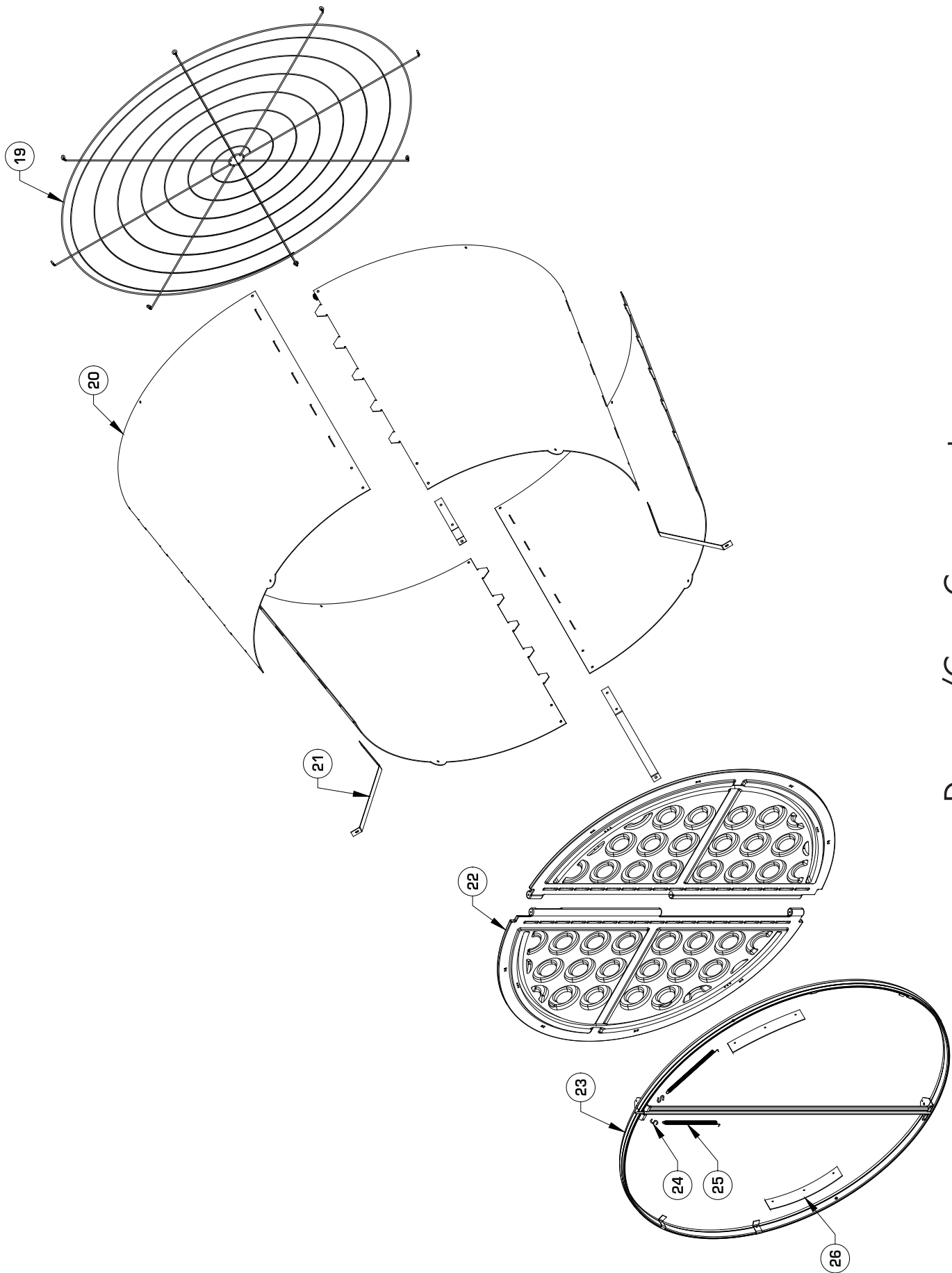

Damper/Cone Components

Catalog No.			
Item	WM54K	Part Name/Description	Qty.
1	FH1654	Orifice Panel, FG	1
2	FP2454	Prop Assembly, 3-Blade, GZ	1
3	various*	V-belt, A-section, Aramid Fiber	1
4	FP2060	Hub with Bearing and Shaft	1
5	FH2137	Propeller Sheave, AL	1
6	KX1130	Shaft Shield, AL	1
7	KN1860	Hex Nut, M25x10mm, ZP	1
8	various*	Motor Sheave 5/8" bore with keyseat, CI	1
9	various*	Motor, 56 Frame	1
10	FH2855	Motor Bracket Support Stiffener, GZ	1
11	FH2831	Mounting Plate for NEMA 56 Motor, CTD-GZ	1
12	FH2505	Mounting Bracket for Belt Tensioner, CTD-GZ	1
13	FH2402K	Belt Tensioner Assembly with 3" Idler Pulley	1
	FH2406	3" Idler Pulley only, with Bolt	1
	FH2459	Tensioner Arm only, AL	1
14	FH1968	1-Hole Pivoting Shutter Clip, BLK PL	8
15	FH1341	Inlet Guard, 2" x 2" Mesh, GZ	1
16	FH1675	Tube Strut, Center, PWDCTD	1
17	FH1659	Drip Shield Plate, AL	1
18	FH1980	Cone/Strut Mounting Bracket, GZ	4
19	FH1454	Outlet Guard, Round, CTD BLK	1
20	FH4655	Discharge Cone Section, PL	4
21	FH2431	Cone Support Bracket, PC type, GZ	4
22	FA2054	Door Assembly w/ Latch (2 Doors), PL	1
23	FA2854	Main Frame Assembly, AL	1
24	KX1059	1" S-Hook, 1/16" Wire, SS	2
25	KX1466	Tension Spring, 0.5"OD x 10.8"L, SS	2
26	FH1365	Wing Add-on Kit, 2 Wings w/ Hardware	1

* Parts listed are for specific fan configuration. Contact office for replacement part numbers for your fan configuration.

WM54K is developed and produced by Munters Corporation, Lansing, Michigan U.S.A. 1-800-227-2376



Munters Europe AB, Isafjordsgatan 1, P.O. Box 1150, SE-164 26 Kista, Sweden. Phone +46 08 626 63 00, Fax +46 8 754 56 66.

Munters Corporation 2691 Ena Drive Lansing, MI 48917 U.S.A. Phone +1 800-227-2376, Fax +1 517-676-7078

www.munters.us

Australia Munters Pty Limited, Phone +61 2 6025 6422, **Brazil** Munters Brasil Industria e Comercio Ltda, Phone +55 41 3317 5050, **Canada/US** Munters Corporation Lansing, MI Phone +1 517 676 7070, **China** Munters Air Treatment Equipment (Beijing) Co. Ltd, Phone +86 10 80 481 121, **Denmark** Munters A/S, Phone +45 9862 3311, **India** Munters India, Phone +91 20 3052 2520, **Indonesia** Munters, Phone +62 818 739 235, **Italy** Munters Italy S.p.A., Chiusavecchia, Phone +39 0183 52 11, **Japan** Munters K.K., Phone +81 3 5970 0021, **Korea** Munters Korea Co. Ltd., Phone +82 2 761 8701, **Mexico** Munters Mexico, Phone +52 818 262 54 00, **Russia** Munters AB, Phone +7 812 448 5740, **Singapore** Munters Pte Ltd., Phone +65 744 6828, **South Africa and Sub-Sahara Countries** Munters (Pty) Ltd., Phone +27 11 997 2000, **Spain** Munters Spain S.A., Phone +34 91 640 09 02, **Sweden** Munters AB, Phone +46 8 626 63 00, **Thailand** Munters Co. Ltd., Phone +66 2 642 2670, **Turkey** Munters Form Endüstri Sistemleri A.Ş, Phone +90 322 231 1338, **USA** Munters Corporation Lansing, MI Phone +1 517 676 7070, **Vietnam** Munters Vietnam, Phone +84 8 3825 6838, **Export & Other countries** Munters Italy S.p.A., Chiusavecchia Phone +39 0183 52 11