

Instruction Manual

Aerotech Guard Kit for CX Series Circulation Fan 74" Fan

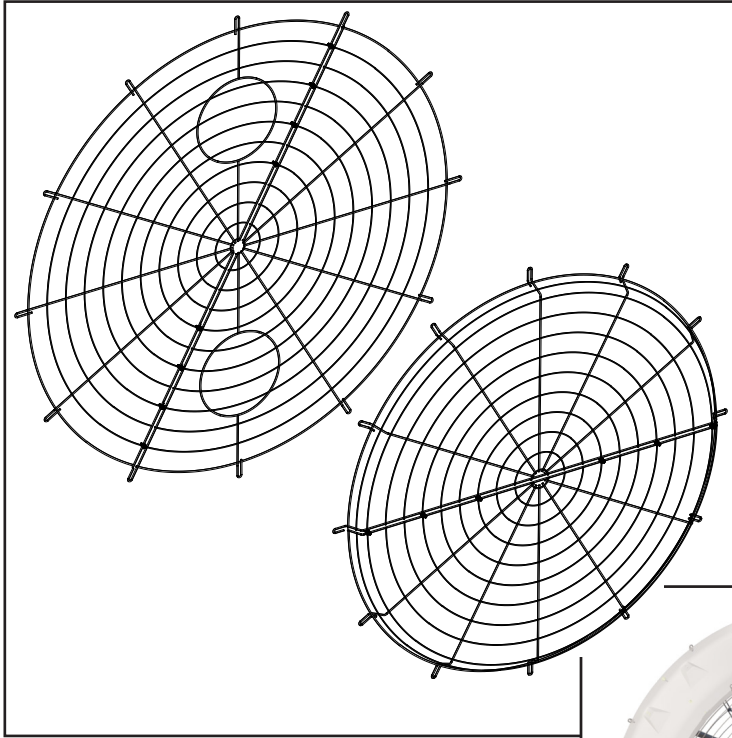

74GK

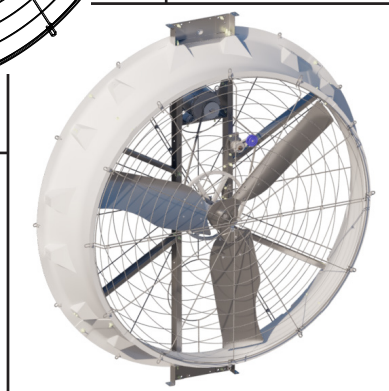

CX74 with 74GK

Guard Kit for CX74 Circulation Fan

Models: 74GK

Guard Kit for CX74 Circulation Fan

Instructions for Use and Maintenance

Thank You:

Thank you for purchasing a Munters 74GK Guard Kit. Munters equipment is designed to be the highest performing, highest quality equipment you can buy. With the proper installation and maintenance it will provide many years of service.

Please Note:

To achieve maximum performance and ensure long life from your Munters product it is essential that it be installed and maintained properly. Please read all instructions carefully before beginning installation.

Warranty:

For Warranty claims information see the “Warranty Claims and Return Policy” form QM1021 available from the [Munters Corporation office at 1-800-227-2376](#) or by e-mail at aghort.info@munters.com.

Conditions and Limitations:

- Products and Systems involved in a warranty claim under the “Warranty Claims and Return Policy” shall have been properly installed, maintained and operated under competent supervision, according to the instructions provided by Munters Corporation.
- Malfunction or failure resulting from misuse, abuse, negligence, alteration, accident or lack of proper installation or maintenance shall not be considered a defect under the Warranty.

Index

Chapters	Page
1. Unpacking the Equipment	4
1.1 Parts List	4
1.2 Dimensions	4
2. Installation Instructions	5
2.1 Guard Installation	5
3. Exploded View and Parts List	9

Unpacking the Equipment

1.

Before beginning installation, check the overall condition of the equipment. Remove packing materials, and examine all components for signs of shipping damage. Any shipping damage is the customer's responsibility and should be reported immediately to your freight carrier.

1.1 Parts List

Each Guard Kit includes:

- 1 - Basket Outlet Guard (2 halves)
- 1 - Inlet Guard (2 halves)
- 2 - Hardware Packages (HP1247) as follows:

HP1247 - 74GK

ID	Qty.	Cat. No.	Description
[A]	20	KS1167	5/16"-18 x 1.25" SRTD HX Flange Bolt, ZP
[B]	20	KN0706	5/16"-18 Serrated Flange Hex Nut, ZP
[C]	24	KW3011	5/16" x 1 1/4" OD Flat Washer, SS

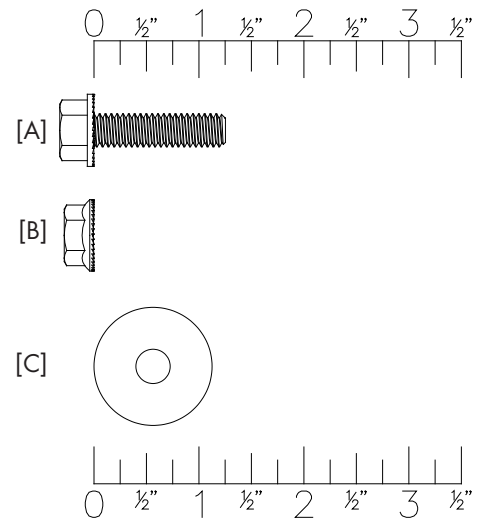

1.2 Dimensions

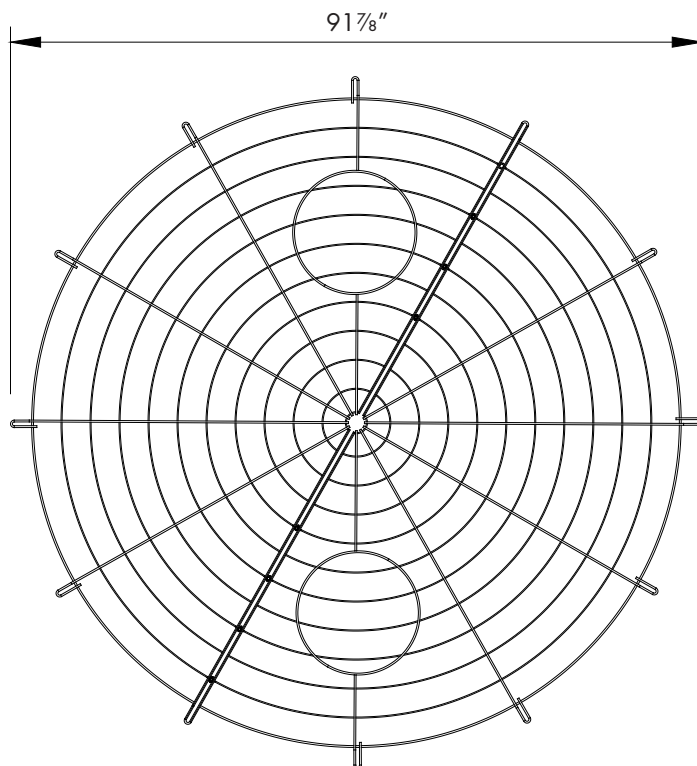

Inlet Guard

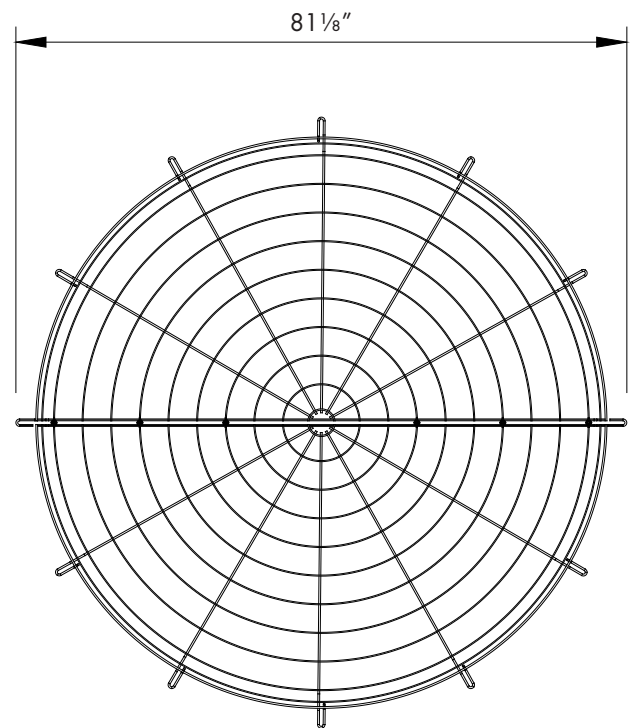

Outlet Guard

Installation Instructions

2.

2.1 Outlet Guard Installation

Step 1

Take the 2 halves of the Outlet Basket Guard and align the center axis of each so the eyelets on the basket part are facing the same direction and the eyelets along the center axis are aligned together. [See Figure 1.](#) Secure the 2 halves of the Outlet Guard together using (6) Bolts [A] and Nuts [B]. [See Figure 1.](#)

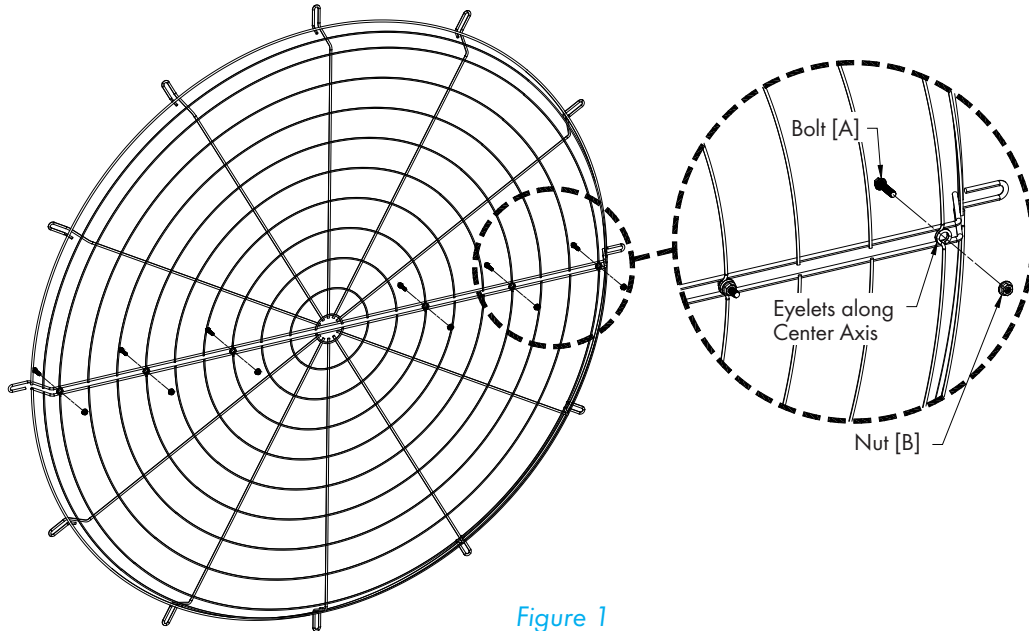

Figure 1

Step 2

Attach the Outlet Basket Guard to the outlet flange of the CX74 fan using (12) Bolts [A], Nuts [B] and (24) Washers [C]. The bolt head and washer should be on outlet side of the guard and go through the eyelet, then the CX74 outlet flange with the nut on the rear side of the outlet flange. [See Figure 2.](#)

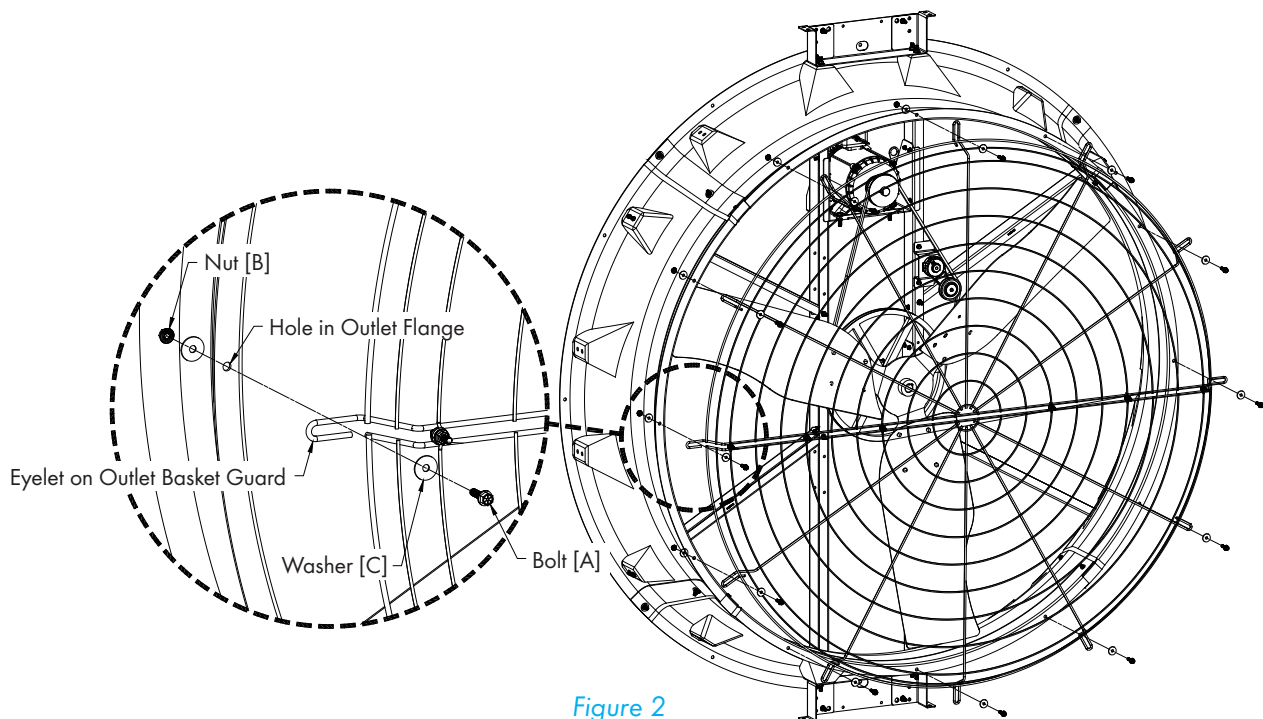

Figure 2

Step 3

Take the 2 Inlet Guard Sections and line the 2 of them up with the Wire Loops on each section are opposite each other and align the center axis of each so the eyelets along the center axis are aligned together. Secure the 2 halves of the Inlet Guard together using (8) Bolts [A] and Nuts [B].

See Figure 3.

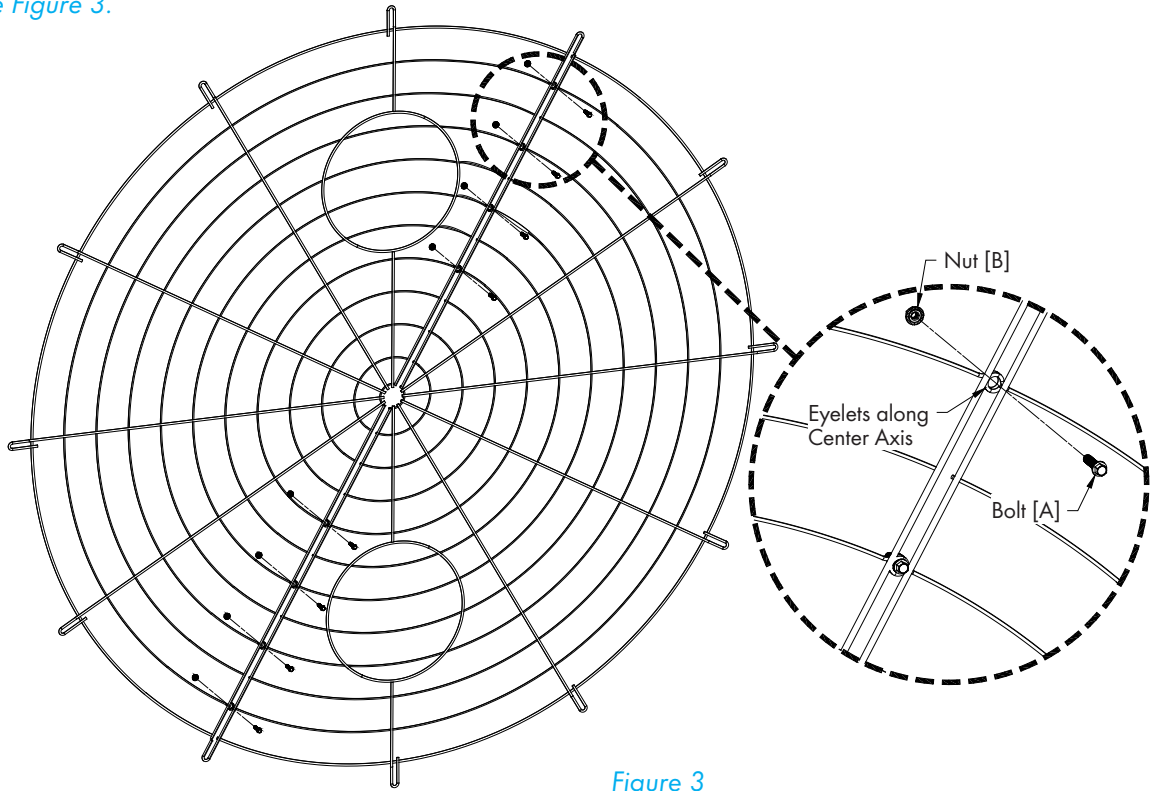

Figure 3

Step 4

On the Inlet Guard there are 2 16½” circles, if guard is to be installed on a Belt Drive CX74 fan, then cut the wires out of center of one of the circles. If guard is to be installed on a Munters Drive CX74, there is no need to cut the wires. See Figure 4.

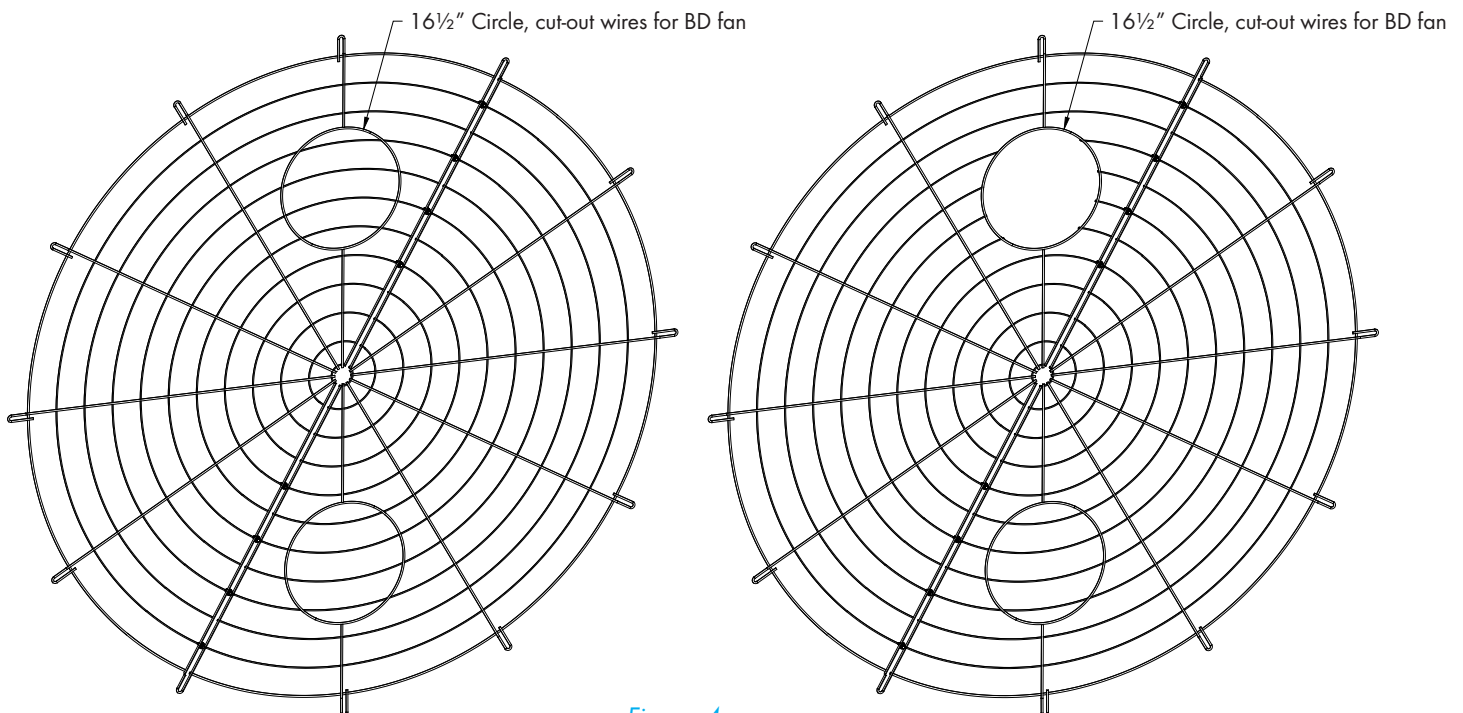

Figure 4

Step 5

Attach the Inlet Guard to the inlet flange of CX74 fan using (12) Bolts [A], Nuts [B] and (24) Washers [C], making sure the circle with the wires cut out are over the motor protruding from the back of the fan. The bolt head and washer should be on the inlet side of the guard and go through the eyelet, then the CX74 inlet flange with the nut on the front side of inlet flange. *See Figure 5.*

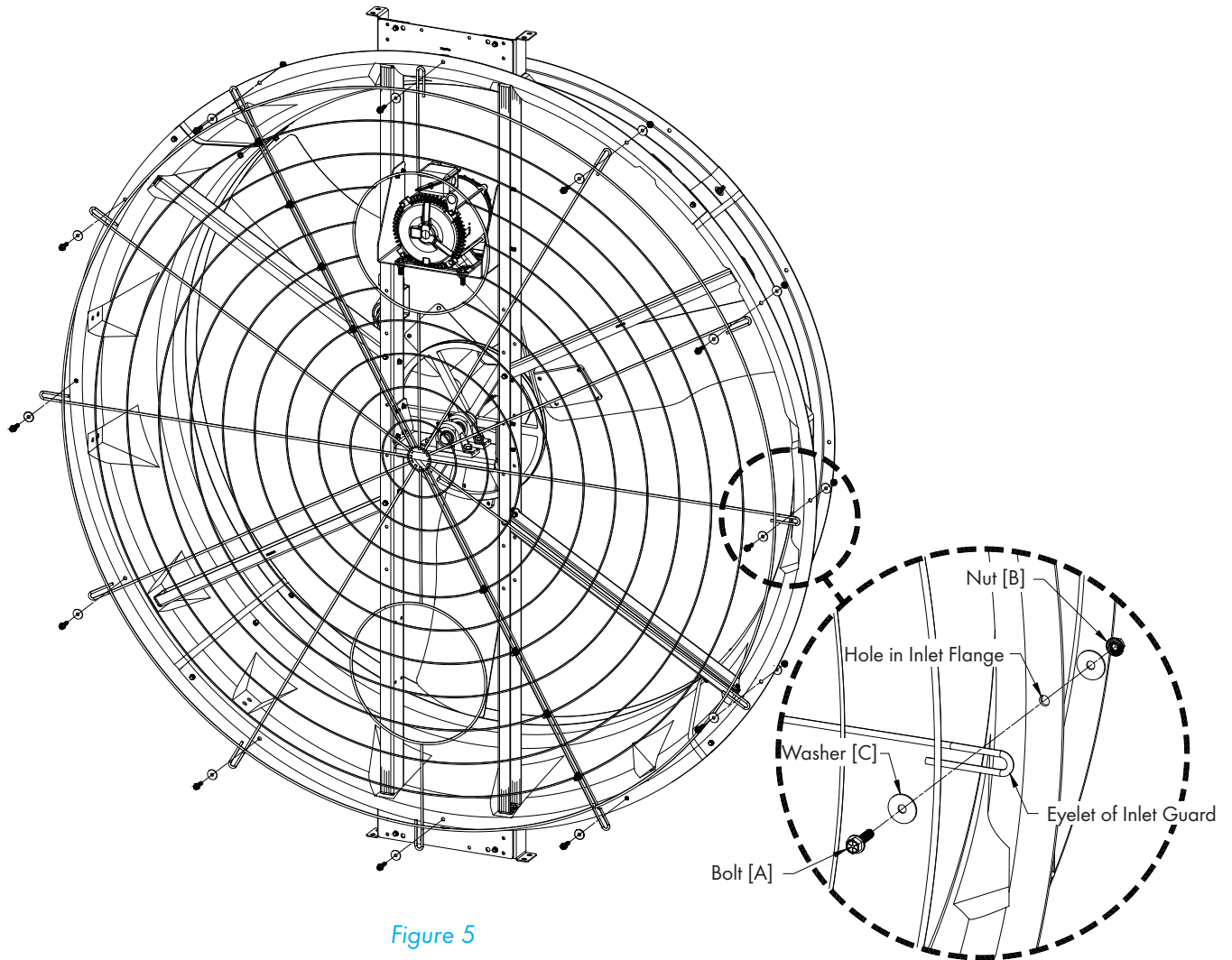
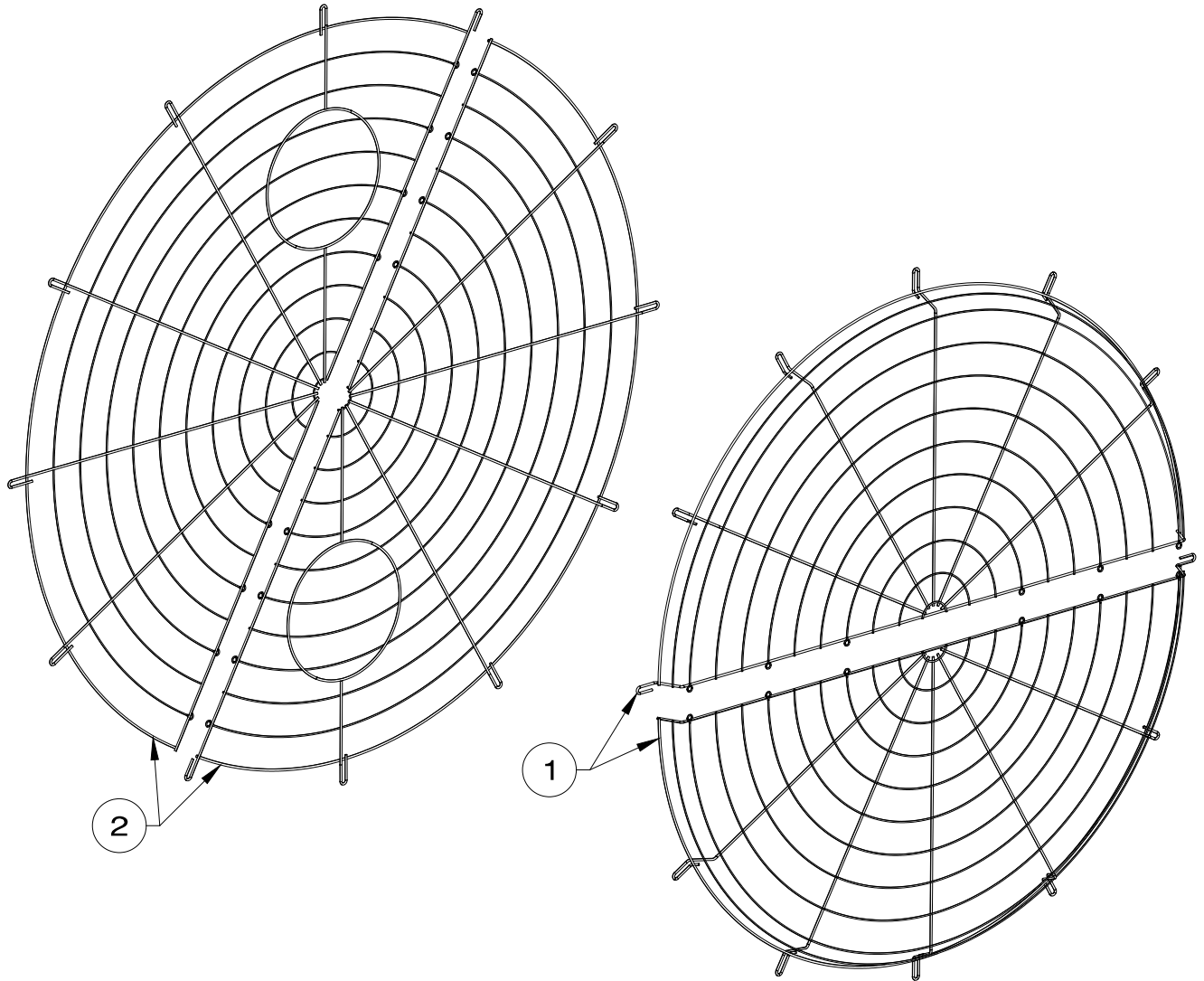

Figure 5



Item	Catalog No.	Description	Qty.
1	FH1694	Outlet Basket Guard, 2 Halves, CX74, CTD-BLACK	1
2	FH1695	Inlet Guard, 2 Halves, CX74, CTD-BLACK	1

This page left blank intentionally

74GK Guard Kit is developed and produced by Munters Corporation, Lansing, Michigan U.S.A. 1-800-227-2376



Munters Europe AB, Isafjordsgatan 1, P.O. Box 1150, SE-164 26 Kista, Sweden. Phone +46 08 626 63 00, Fax +46 8 754 56 66.

Munters Corporation 2691 Ena Drive Lansing, MI 48917 U.S.A. Phone +1 800-227-2376, Fax +1 517-676-7078

www.munters.us

[Australia](#) Munters Pty Limited, Phone +61 2 6025 6422, [Brazil](#) Munters Brasil Industria e Comercio Ltda, Phone +55 41 3317 5050, [Canada/US](#) Munters Corporation Lansing, MI Phone +1 517 676 7070, [China](#) Munters Air Treatment Equipment (Beijing) Co. Ltd, Phone +86 10 80 481 121, [Denmark](#) Munters A/S, Phone +45 9862 3311, [India](#) Munters India, Phone +91 20 3052 2520, [Indonesia](#) Munters, Phone +62 818 739 235, [Italy](#) Munters Italy S.p.A., Chiusavecchia, Phone +39 0183 52 11, [Japan](#) Munters K.K., Phone +81 3 5970 0021, [Korea](#) Munters Korea Co. Ltd., Phone +82 2 761 8701, [Mexico](#) Munters Mexico, Phone +52 818 262 54 00, [Russia](#) Munters AB, Phone +7 812 448 5740, [Singapore](#) Munters Pte Ltd., Phone +65 744 6828, [South Africa and Sub-Sahara Countries](#) Munters (Pty) Ltd., Phone +27 11 997 2000, [Spain](#) Munters Spain S.A., Phone +34 91 640 09 02, [Sweden](#) Munters AB, Phone +46 8 626 63 00, [Thailand](#) Munters Co. Ltd., Phone +66 2 642 2670, [Turkey](#) Munters Form Endüstri Sistemleri A.Ş, Phone +90 322 231 1338, [USA](#) Munters Corporation Lansing, MI Phone +1 517 676 7070, [Vietnam](#) Munters Vietnam, Phone +84 8 3825 6838, [Export & Other countries](#) Munters Italy S.p.A., Chiusavecchia Phone +39 0183 52 11