

Original instructions

User manual

MG50, MG90

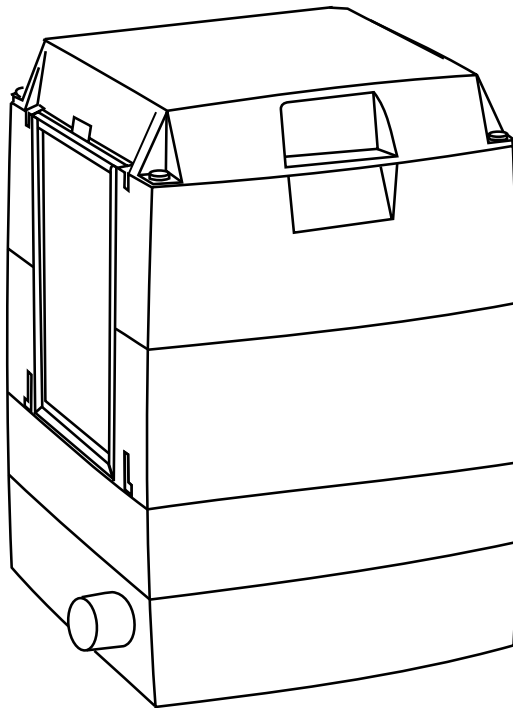

Desiccant dehumidifier

190TGB-1004-N1402

© Munters Europe AB 2014

Important user information

Intended use

Munters dehumidifiers are intended to be used for the dehumidification of air. Any other use of the unit, or use which is contrary to the instructions given in this manual, can cause personal injury and damage to the unit and other property.

No modification of the unit is allowed without prior approval by Munters. Attachment or installation of additional devices is only allowed after written agreement by Munters.

Warranty

The warranty period is valid from the date the unit left our factory, unless otherwise stated in writing. The warranty is limited to a free exchange of parts or components which have failed as a result of defects in materials or workmanship.

All warranty claims must include proof that the fault has occurred within the warranty period and that the unit has been used in accordance with the specifications. All claims must specify the unit type and fabrication number. This information is stamped on the identification plate, see section *Marking*.

It is a condition of the warranty that the unit for the full warranty period is serviced and maintained as described in section *Service and maintenance*. The service and maintenance must be documented for the warranty to be valid.

Safety

Information about dangers are in this manual indicated by the common hazard symbol:



WARNING!

Indicates a possible danger that can lead to personal injury.



CAUTION!

Indicates a possible danger that can lead to damage to the unit or other property, or cause environmental damage.

NOTE! *Highlights supplementary information for optimal use of the unit.*

Conformity with Directives

The dehumidifier is in conformity with the essential safety requirements of the Machinery Directive 2006/42/EC, the Low Voltage Directive 2006/95/EC, the RoHS Directive 2011/65/EC and the EMC Directive 2004/108/EC. The dehumidifier is manufactured by an ISO 9001:2008 accredited manufacturing organisation.

Copyright

The contents of this manual can be changed without prior notice.

NOTE! *This manual contains information which is protected by copyright laws. It is not allowed to reproduce or transmit any part of this manual without written consent from Munters.*

Please send any comments regarding this manual to:

Munters Europe AB

Technical Documentation

P.O. Box 1150

SE- 164 26 KISTA Sweden

e-mail: t-doc@munters.se

Table of contents

Important user information	ii	4.5 Mounting the unit on the wall	8
Intended use	ii	4.6 Installation examples	10
Warranty	ii	4.6.1 Closed system	10
Safety	ii	4.6.2 Open system	11
Conformity with Directives	ii	4.7 Electrical connections	12
Copyright	ii	4.8 Connecting the humidistat	12
Table of contents	iii	5 Operation	13
1 Introduction	1	5.1 Safety	13
1.1 About this manual	1	5.2 Prior to start	13
1.2 Unintended use	1	5.3 Start	14
1.3 Safety	2	5.3.1 Manual operation	14
1.4 Marking	3	5.3.2 Automatic operation	14
2 Dehumidifier design	4	5.4 Stop the unit	14
2.1 Product description	4	6 Service and maintenance	15
2.2 Principle of operation	4	6.1 General	15
3 Transport, inspection and storage	5	6.2 Maintenance schedule	15
3.1 Transport	5	6.3 Filter replacement	16
3.2 Packaging and delivery inspection	5	7 Fault tracing	17
3.3 Storing the equipment	5	8 Technical specification	18
4 Installation	6	8.1 Dimensions and service space	18
4.1 Safety	6	8.2 Capacity diagrams	19
4.2 Site requirements	6	8.3 Fan curves	20
4.3 Connection of ducts and hoses	7	8.4 Technical data	21
4.4 Hose length and orifice plate affects the airflow	7	9 Scrapping	22
		10 Contact Munters	24

1 Introduction

1.1 About this manual

This manual is written for the user of the dehumidifier. It contains necessary information for how to install and use the dehumidifier in a safe and efficient way. Read through the manual before the dehumidifier is installed and used.

Contact your nearest Munters office if you have any questions regarding the installation or the use of your dehumidifier.

This manual must be stored in a permanent location close to the dehumidifier.

1.2 Unintended use

- The dehumidifier is not intended for outdoor installation.
- The dehumidifier is not intended for use in classified areas where explosion safety compliant equipment is required.
- The dehumidifier must not be installed near any heat generating devices that can cause damage to the equipment.



CAUTION!

Do not sit, stand, or place any objects on the unit.

1.3 Safety

Every measure has been taken in the design and manufacture of the dehumidifier to ensure that it meets the safety requirements of the directives and standards listed in the EC Declaration of Conformity.

The information in this manual shall in no way take precedence over individual responsibilities or local regulations.

During operation and other work with a machine it is always the responsibility of the individual to consider:

- The safety of all persons concerned.
- The safety of the unit and other property.
- The protection of the environment.

The types of dangers that are indicated in this manual are described in section *Important user information*.



WARNING!

- *The unit must not be splashed with or immersed in water.*
- *All electrical installations must be carried out by a qualified electrician and in accordance with local regulations.*
- *The unit must be connected to an earthed electrical outlet.*
- *Do not connect the unit to other mains voltage than specified on the identification plate.*
- *Do not operate the unit if the power plug or cord is damaged, risk of electrical shock.*
- *Do not pull the plug with wet hands, risk of electrical shock.*
- *Do not insert fingers or any other objects into the air vents, rotating fans are inside.*
- *Do not cover the unit as that can block air intake or outlet and cause a fire.*
- *If the unit has overturned, cut the power immediately.*
- *Always contact Munters for service or repair.*

1.4 Marking

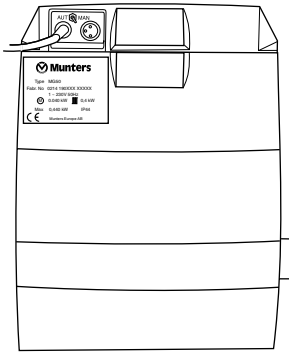

Figure 1.1 Identification plate position



Figure 1.2 Identification plate

Explanation of "Fabr. No" on the identification plate:

- 09: Year of manufacture
- 19: Week of manufacture
- 190XXX: Article number
- XXXXX: Serial number

2 Dehumidifier design

2.1 Product description

The desiccant dehumidifiers are designed to effectively dehumidify the air. Their compact form is comprised of sections that are held together with just four bolts. The fan, desiccant rotor and reactivation heater are held in their respective sections without any further means of attachment. One of the sections contains a distribution chamber with insulated sections that provide exactly the right balance between the dehumidifying and reactivation air flows. The sturdy outer casing is made of corrosion resistant, die-cast aluminium.

The electrical equipment complies with the EN 60204-1 standard. The dehumidifier is manufactured according to uniform European standards and the established requirements for CE-marking.

2.2 Principle of operation

The desiccant rotor is the adsorption dehumidifying component in the unit. The rotor structure is comprised of a large number of small air channels.

The desiccant rotor is made of a composite material that is highly effective in attracting and retaining water vapour. The rotor is divided in two zones. The airflow to be dehumidified, **process air**, passes through the largest zone of the rotor and then leaves the rotor as **dry air**. Since the rotor rotates slowly, the incoming air always meets a dry zone on the rotor, thus creating a continuous dehumidification process.

The airflow that is used to dry the rotor, **reactivation air**, is heated. The reactivation air passes through the rotor in the opposite direction to the process air and leaves the rotor as **wet air** (warm, moist air). This principle enables the dehumidifier to work effectively, even at freezing temperatures.

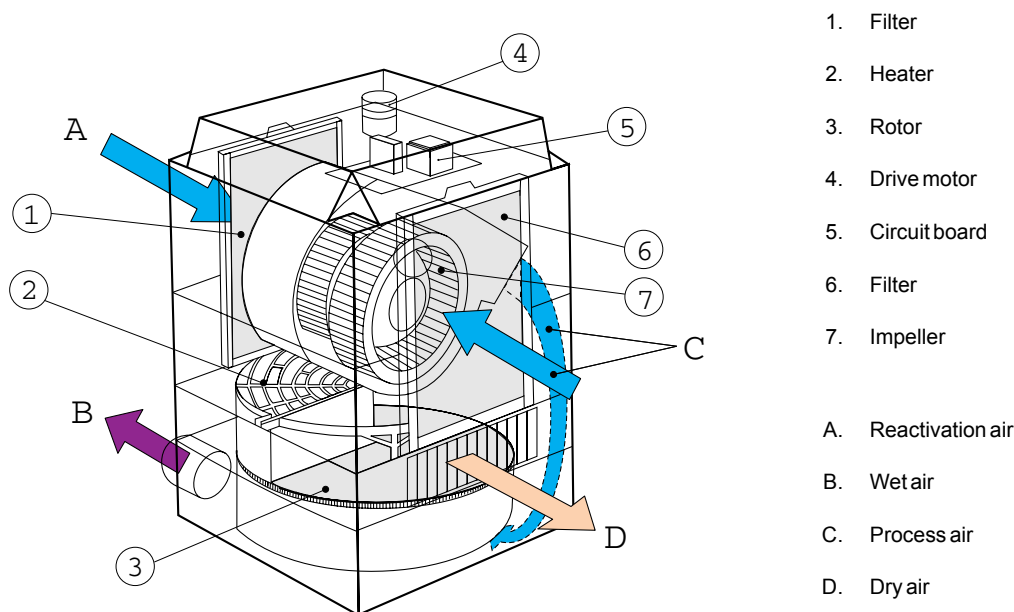

Figure 2.1 Principle of operation

3 Transport, inspection and storage

3.1 Transport

Use the handles when lifting the unit.

Use the original packaging when shipping the unit.

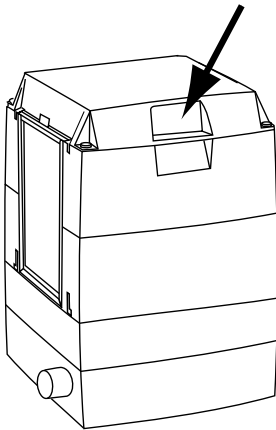

Figure 3.1 Handles

3.2 Packaging and delivery inspection

1. Inspect the delivery and compare with the delivery note, order confirmation or other delivery documentation. Make sure that everything is included and nothing is damaged.
2. Contact Munters immediately if the delivery is not complete in order to avoid installation delays.
3. If the unit is to be put into storage prior to installation, see section *Storing the equipment*.
4. Remove all packaging material from the unit, and make sure that no damage has occurred during transportation.
5. Any visible damage must be reported in writing to Munters within 5 days and prior to installation of the unit.
6. Dispose of the packaging material according to local regulations.

3.3 Storing the equipment

Follow these instructions if the dehumidifier is to be stored prior to installation:

- Place the dehumidifier in an upright position on a horizontal surface.
- Re-use the packaging material to provide protection for the unit.
- Protect the dehumidifier from physical damage.
- Store the dehumidifier under cover and protect it from dust, frost, rain and aggressive contaminants.

4 Installation

4.1 Safety



WARNING!

Do not connect the unit to other mains voltage than specified on the identification plate.

The unit must be connected to an earthed electrical outlet.

Do not operate the unit if the power plug or cord is damaged.



CAUTION!

Do not sit, stand, or place any objects on the unit.

4.2 Site requirements

The dehumidifier is intended for indoor installation. It must be placed in an upright position inside or outside the space to be dehumidified and at least 15 cm above the floor.

Avoid installing the dehumidifier where there is a risk of water entering the unit, or in a very dusty environment.

For unit and service dimensions, see section 8.1, *Dimensions and service space*.

NOTE! It is important that the intended installation site meets the requirements in order to achieve the best possible performance and trouble-free operation.

Do not position the wet air side or rear side (see *Figure 4.1*) near the wall or heat-sensitive objects.

Position the dehumidifier so that there is enough room for air circulation.

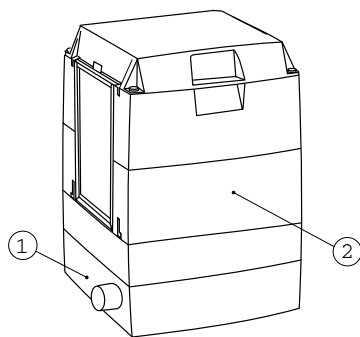

Figure 4.1

1. Wet air side
2. Rear side

4.3 Connection of ducts and hoses

Follow the instructions below when attaching ducts or flexible hoses to the air connections. The process and reactivation air inlet and dry air outlet can be connected to a duct system or be used with free inlet and outlet. The wet air outlet must always be connected to a duct or hose, which must be fitted at a downward angle (away from the dehumidifier) so that condensation is drained.

- Duct length must be kept as short as possible to minimise static pressure loss.
- All duct and hose connections must be air tight and vapour tight to ensure full performance.
- The wet air duct or hose must be mounted at a downward angle so that condensation can be drained. The wet air hose or duct must have suitable drainage at low temperatures to prevent pooling of condensate. Alternatively, condensation can be avoided by insulating the duct with at least 25 mm of insulation.
- Cover the duct opening for outdoor air with mesh to prevent birds and rodents from entering the unit. Position the opening so that rain and snow cannot enter the duct.
- The wet air duct or hose must be corrosion resistant and able to withstand temperatures up to 70 °C.
- The wet air is normally transported outdoors. In large premises where the dehumidifier is outside of the space to be dehumidified, the wet air can be led away near the unit. Position the outlet so that the wet air does not blow towards moisture-sensitive objects.
- The minimum distance between the reactivation inlet or wet air outlet and the wall is 0.5 m.
- The filters for both process and reactivation air can be replaced without having to detach ducts or hoses.



CAUTION!

If there is a risk of freezing temperatures, the wet air ducts must be insulated.

NOTE! *Noise reduction can be achieved by connecting ducts to the dehumidifier.*

4.4 Hose length and orifice plate affects the airflow

Wet air / reactivation air

The dehumidifier is equipped with an orifice plate (A) in the wet air outlet. When a wall pipe is connected to the hose (see 4.5, *Mounting the unit on the wall*), or if the flexible hose or duct is longer than 5 m (max. 10 m), the orifice plate must be removed.

Dry air / process air

The hose or duct for dry and process air can have a total length of 10 m before dehumidification capacity is affected. The connection piece (B) makes it possible to connect the dry air outlet to a hose or duct system.

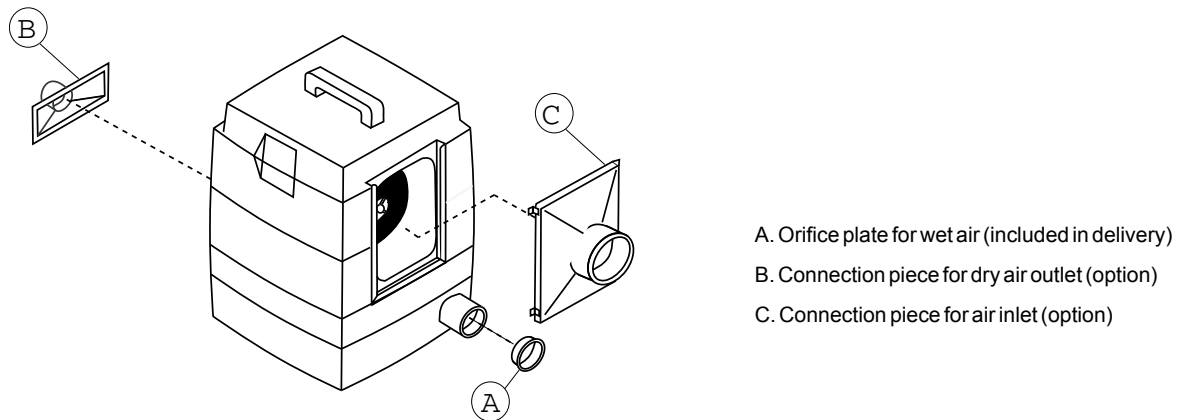

Figure 4.2 Connection to air ducts

4.5 Mounting the unit on the wall

The MG unit can be mounted on the wall in two different ways using a wall bracket (optional equipment), see *Figure 4.3* and *Figure 4.4*. This enables optimized positioning of the wet and dry air outlets to meet any desired requirements.

- Alternative 1: The wet air outlet is placed near the wall on the right side of the unit.
- Alternative 2: The front of the unit is positioned against the wall so that the wet air outlet is far from the wall on the left side of the unit.

NOTE! In both alternative 1 and 2, a wood block (or similar) must be placed between the wall bracket and the wall. The wood block is needed to ensure there is sufficient space for the air to circulate around the unit and to make it possible to mount the humidistat contact (alternative 2).

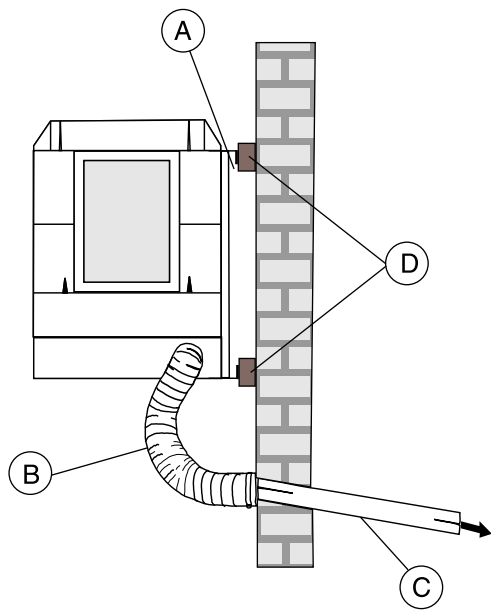

Figure 4.3 Wall-mounted unit, alternative 1

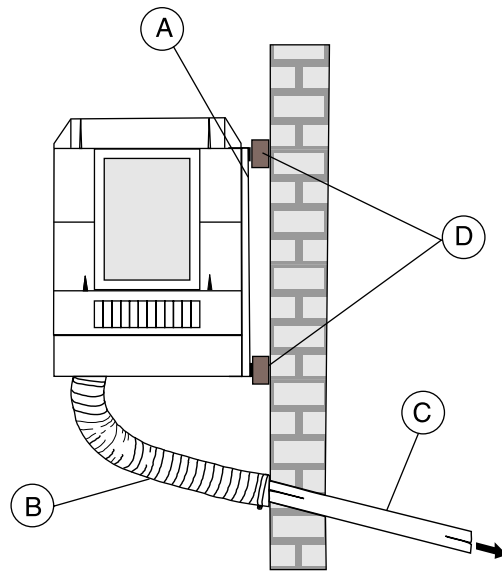

Figure 4.4 Wall-mounted unit, alternative 2

A. Wall bracket (option)

B. Wet air hose

C. Wall pipe (option). Mounted at a downward angle towards the outside of the building.

D. Wood block (depth 30 mm, width 40 mm, length 350 mm)

NOTE! Mount the wall pipe with the thin pipe facing down to enable condensate drainage through the pipe, see Figure 4.5.

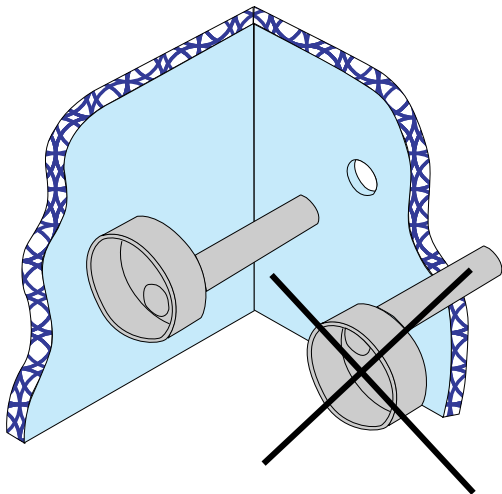

Figure 4.5 Wall pipe

4.6 Installation examples

4.6.1 Closed system

The air in the room is circulated through the dehumidifier.

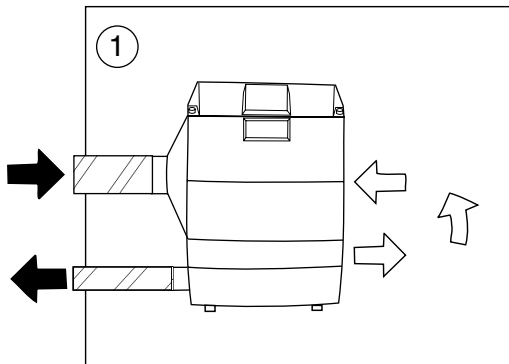

Figure 4.6 Closed system, dehumidifier located in the room.

1. Dehumidifier located in the room:

The wet air outlet is connected to a hose and is then emitted outside the room (outdoors). The reactivation air is taken from the outside via a hose or duct connected to a connection piece.

NOTE! A short hose (~0.3 m) on the dry air outlet can improve air circulation and eliminate the risk of short-circuiting dry air and process air.

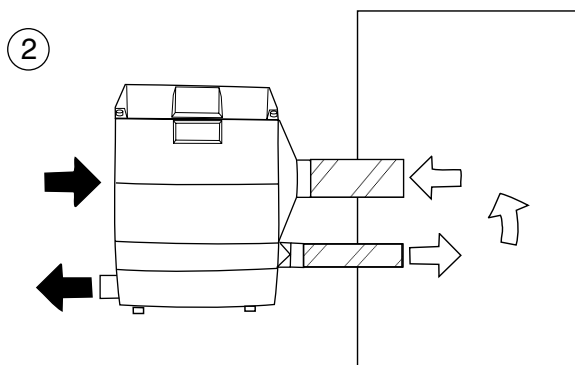

Figure 4.7 Closed system, dehumidifier located outside the room.

2. Dehumidifier located outside the room:

The process air is taken from the dehumidified room via a hose or duct connected to a connection piece. The dry air is emitted into the room through a hose connected to a connection piece.

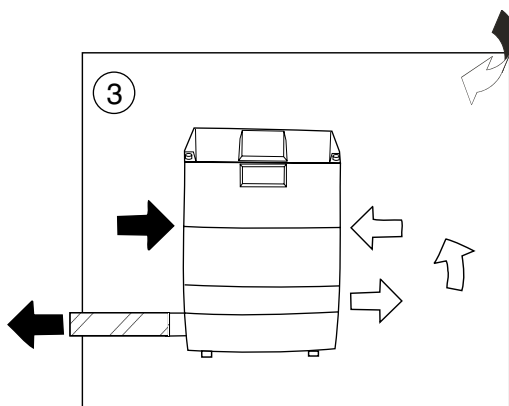

Figure 4.8 Closed system, dehumidifier located in the room.

3. Dehumidifier located in the room:

The wet air outlet is connected to a hose and the wet air is emitted outside of the room (outdoors). The reactivation air is taken from the dehumidified room.

The dehumidification capacity becomes 2/3 of that indicated in the diagram, see chapter 8.2, *Capacity diagrams*.

NOTE! A short hose (~0.3 m) on the dry air outlet can improve air circulation and eliminate the risk of short-circuiting dry air and process air.

4.6.2 Open system

The space is ventilated with dehumidified air.

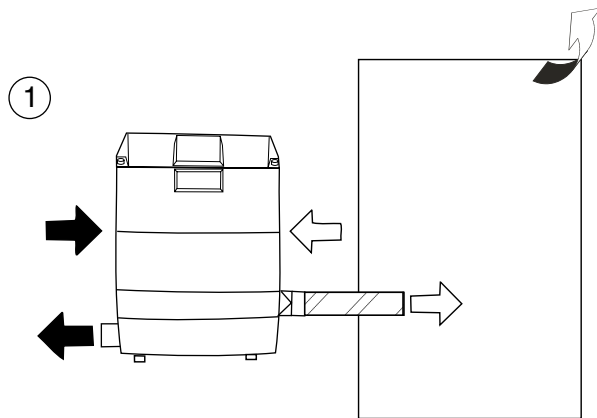

1. Dehumidifier located outside the room:
Dry air is emitted into the room via a hose or duct connected to a connection piece.

Figure 4.9 Open system, dehumidifier located outside the room.

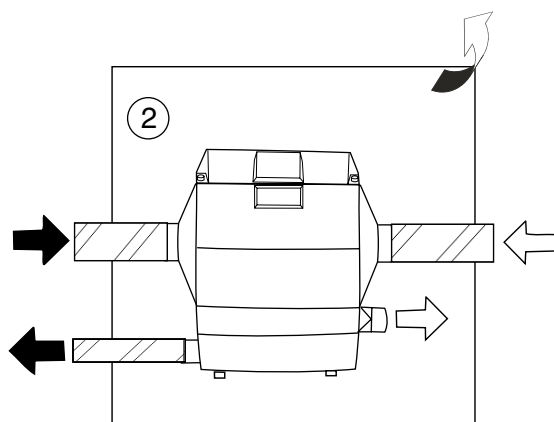

2. Dehumidifier located in the room:
The wet air outlet is connected to a hose and the wet air is emitted outside the room (outdoors). The reactivation air and process air are taken into the unit via hoses or ducts and connection pieces. Dry air is emitted into the room via a connection piece.

Figure 4.10 Open system, dehumidifier located in the room.

4.7 Electrical connections

Included with the delivery is a 2.5 m long power cable with a plug for connection to an earthed outlet. The voltage and frequency are specified on the unit identification plate, see section 1.4, *Marking*.

4.8 Connecting the humidistat

The dehumidifier comes with a socket designed for the connection of a single step humidistat with low voltage. See the figure below. The humidistat can be ordered as an accessory.

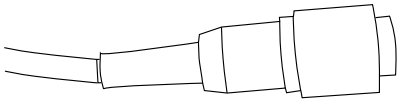

Figure 4.11 Connector for humidistat cable

The connection socket for the humidistat is located on the front of the unit.

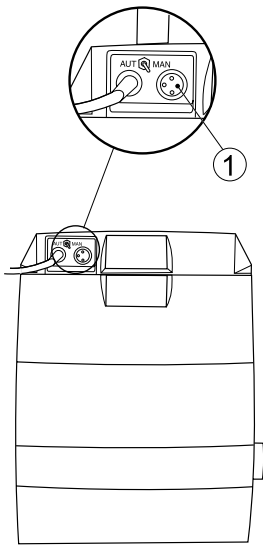

Figure 4.12 Humidistat connection socket (1)

A room humidity sensor is to be mounted 1-1.5 m above the floor. It must be positioned so that it is not directly exposed to dry air from the unit or to humid air flowing in through opening doors. Position it away from heat sources and direct sunlight.

The humidistat must be a single-stage humidistat and connected so that the control circuit closes when relative humidity increases. The connection cable must be screened and equipped with a copper conductor with a minimum cross-section area of $2 \times 0.75 \text{ mm}^2$.

If the unit is used together with an external humidistat, operation mode **A** or **B** can be used.

Mode A: The humidistat regulates the entire dehumidifier ON/OFF (standard mode).

Mode B: The humidistat only regulates the reactivation heater and the fan operates continuously.

Contact Munters for changing the operation mode.

5 Operation

5.1 Safety

**WARNING!**

Do not operate the unit if the power plug or cord is damaged.

Do not insert fingers or any other objects into the air vents.

The unit can restart automatically without warning following a power failure.

**CAUTION!**

Do not sit, stand, or place any objects on the unit.

5.2 Prior to start

The following checks must be carried out before the dehumidifier is started for the first time:

1. Check that the unit is correctly connected to the power source according to the identification plate, see chapter 1.4, *Marking*. If a fused switch has been fitted, the fuse data of the switch must be checked.
2. If a humidistat has been installed, the user must check that it has been correctly positioned in the room and has been correctly connected to the unit, see chapter 4.8, *Connecting the humidistat*.

5.3 Start

5.3.1 Manual operation

Set the mode selector switch to **MAN** and connect the dehumidifier to a wall socket, or operate the external circuit breaker, and check that the unit starts.

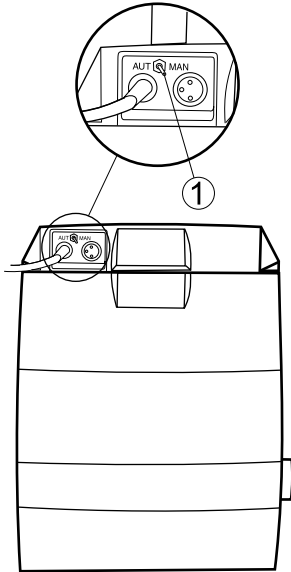

Figure 5.1 MAN-AUT mode selector switch (1)

5.3.2 Automatic operation

NOTE! To enable running the unit in automatic mode, a single-stage humidistat (option) must be installed and connected to the unit.

1. Connect the dehumidifier to a wall socket, or operate the external circuit breaker, and check that the unit starts.
2. Set the mode selector switch to the AUT position and adjust the humidistat setpoint to the minimum value for relative humidity (RH).
3. Slowly increase the humidistat setpoint until the dehumidifier stops. This is done to check that the humidistat and dehumidifier are operating correctly.

NOTE! The fan can continue to rotate when the reactivation heater has been switched off depending on the operation mode. More information is available in chapter 4.8, Connecting the humidistat.

4. Adjust the humidistat setpoint to the desired RH value.

5.4 Stop the unit

To stop the unit, disconnect it from the power source or use the external circuit breaker.

6 Service and maintenance

6.1 General



WARNING!

- Do not attempt to repair, dismantle or modify this unit.
- Remove the mains plug from the socket before starting any maintenance work.

The dehumidifier is designed for continuous use over a long period of time with a minimal amount of supervision. Under normal operating conditions, maintenance requirements are minimal. The service interval depends mainly on the operational conditions and working environment.

NOTE! It is recommended to contact Munters for service or repair. Operating faults can occur if the unit is maintained insufficiently or incorrectly.

Munters Service can offer a service plan adapted to suit the conditions of a specific installation. See contact addresses on the back page of this manual.

6.2 Maintenance schedule

Munters recommends the following maintenance schedule. The schedule contains inspection and maintenance procedures as well as the recommended intervals for units used under normal operating and environmental conditions. If the process air contains a lot of dust, preventative maintenance should be performed at shorter intervals than those specified below.

Component	Inspection/maintenance	
	3-6 months	12 months
Process and Reactivation filter.	Clean the filter cassette ⁽¹⁾ and replace the filter as necessary.	Clean the filter housing and replace the filter
Unit housing.	Check for physical damage and clean the outside of the unit as necessary.	Check for physical damage and clean the outside of the unit as necessary. Check any line connections to ensure they are properly attached and that there are no air leaks.
Humidistat.	No corrective action/check	Check sensor functions and calibrate if necessary. Contact your Munters product service department as required
Functionality and performance check	No corrective action/check	Perform a complete functionality and performance check, and replace worn parts as necessary.
⁽¹⁾ Ensure that the arrow points toward the dehumidifier when changing the filter cassette.		

Table 6.1 Maintenance schedule

6.3 Filter replacement

1. Remove the filter cassette by sliding it upwards according to *Figure 6.1*.
2. Clean the filter holder and fit a new filter cassette.

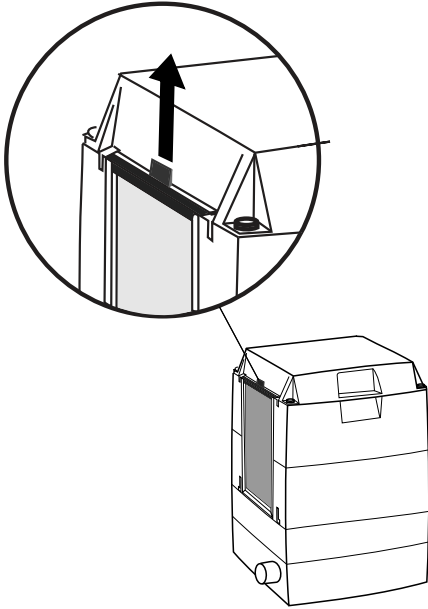

Figure 6.1 Removing the filter cassette

7 Fault tracing

Symptom	Possible cause	Corrective action
Unit has stopped.	Failure of the electrical supply	Check power supply to the unit.
	The unit was set to automatic mode by mistake with no humidistat connected. Humidistat fault (automatic mode).	Set to manual operating mode and check that the dehumidifier starts. If the unit starts, the problem probably lies with the humidistat. Check the humidistat by checking that the dehumidifier starts when the setpoint of the humidistat is lowered. Reset the humidistat setpoint after the check. Calibrate the humidistat as necessary or replace it.
	The thermal protection in the fan motor has been triggered.	<ul style="list-style-type: none"> - Switch off the unit and disconnect the power supply - Remove the connection pieces for the hoses or ducts and the filter cartridge on the process and/or reactivation side. - Check that the impellers which are now accessible rotate freely.
	The high-temperature fuse has been tripped.	<p>Check that the filters and hoses or ducts are not clogged and reset the fuse. Before the fuse can be reset, the unit must be disconnected from the power source and then reconnected once it has cooled. The primary causes behind triggering of the high-temperature fuse are:</p> <ul style="list-style-type: none"> - Fault in the reactivation airflow. - Blocked filter, hose or duct. - Blocked impeller.
Loss of performance: The dehumidifier is in operation but is not controlling the humidity.	Reactivation temperature is too low.	Check that the orifice plate (A) is fitted.
	The reactivation heater is not operating.	Check that the reactivation heater is working by measuring current consumption, see chapter 8.4, <i>Technical data</i> .
	The reactivation airflow is incorrect	Check the filter and any hoses or ducts for leakage or blockage. The use of a restricting flange in combination with wall pipes can also cause an incorrect reactivation airflow.
	Rotor drive mechanism fault	Check through the dry air outlet that the rotor rotates at approx. 10 revolutions per hour.

Table 7.1 Fault tracing list

8 Technical specification

8.1 Dimensions and service space

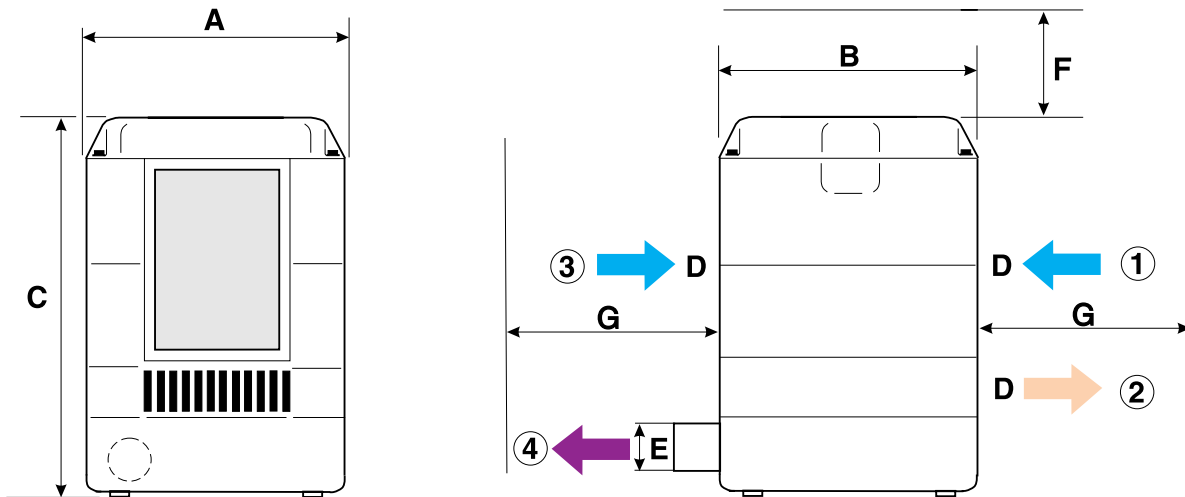

Figure 8.1 Dimensions

- | | |
|----------------------|---------------------------|
| 1. Process air inlet | 3. Reactivation air inlet |
| 2. Dry air outlet | 4. Wet air outlet |

NOTE! The specified dimensions and weights apply to both the MG50 and MG90 dehumidifier.

Width (A)	Depth (B)	Height (C)	Diameter ¹ (D)	Diameter (E)	Service access area (F)	Service access area (G)	Weight
275 mm	275 mm	392 mm	62,5 mm	50 mm	350 mm	500 mm	10 kg
(1) Adapter available as an option to convert a rectangular opening to a round one.							

Table 8.1 Dimensions and weight

8.2 Capacity diagrams

Approximate capacity in kg/h. For detailed information, please contact your nearest Munters location.

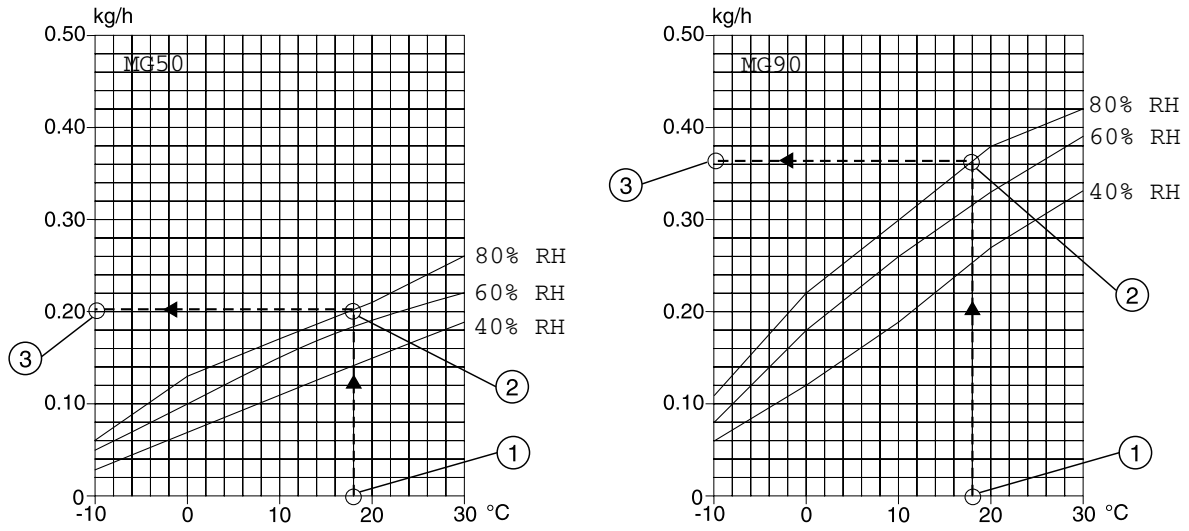

Figure 8.2 Capacity diagrams

1. Temperature, process air (°C)
2. Relative humidity, process air (%RH)
3. Dehumidification capacity (kg/h), (moisture removal (kg/hour))

8.3 Fan curves

The fan curves are based on an air inlet temperature of 20 °C and air density of 1.2 kg/m³

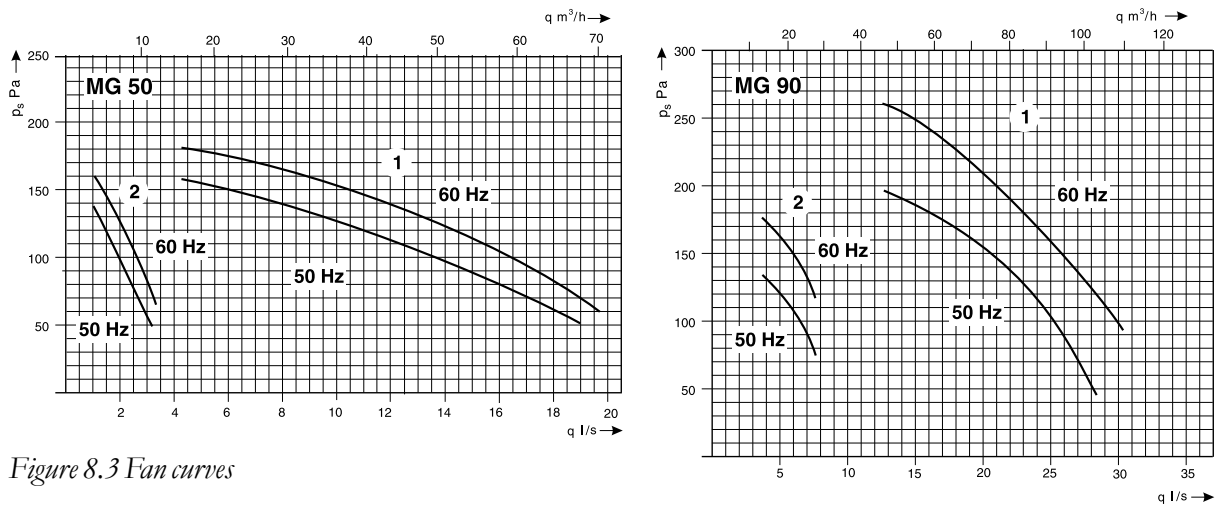

Figure 8.3 Fan curves

Symbols

q: Airflow, ls, m³/h

ps: Available static pressure

1: Process air

2: Reactivation air. Without orifice plate on wet air outlet ⁽¹⁾.

(1) The dehumidifier is delivered with an orifice plate on the wet air outlet.

8.4 Technical data

	MG50	MG90
Process air⁽¹⁾		
Free-blowing air 50 Hz (m³/h)	80	110
Free-blowing air 60 Hz (m³/h)	85	120
Rated airflow (m³/h)	50	90
Available static pressure 50 Hz (Pa)	100	100
Available static pressure 60 Hz (Pa)	120	120
Fan motor power (kW)	0.040	0.090
Reactivation air⁽¹⁾		
Rated airflow (m³/h)	12	20
Available static pressure (Pa)	50	100
Fan motor power (kW) ⁽²⁾	-	-
Reactivation air heater		
Heater power (kW)	0.4	0.65
Temperature increase across heater (°C)	97	
Miscellaneous data		
Max. noise level unducted (dBA)	48	56
Drive motor power (W)	5	
IEC protective class (casing)	IP44	
IEC protective class (electric panel)	IP54	
Fan motor winding insulation class	Class B	
Drive motor winding insulation class	Class B	
Rotor type	HPS	
Environmental conditions		
Operating temperature (°C)	-20... +40	
Maximum installation altitude, above sea level (m)	2000	
Transport and storage temperature (°C)	-20... +70	
(1) Figures quoted are based on fan inlet temperature of 20°C, and an air density of 1,2 kg/m³		
(2) Common motor for process and reactivation fans		

Table 8.2 Technical data

Total power, voltage and current								
Unit	MG50				MG90			
Voltage (V)	115	200	230	240	115	200	230	240
Frequency (Hz)	50-60	50-60	50-60	50-60	50-60	50-60	50-60	50-60
Total power (W)	440	440	440	440	740	740	740	740
Current (A)	3,8	2,2	1,9	1,8	6,4	3,7	3,2	3,1

Table 8.3 Power, voltage and current

9 Scrapping

The unit must be scrapped in accordance with applicable legal requirements and regulations. Contact your local authorities.

The rotor material is not combustible, and should be deposited like glass fibre materials.

If the rotor has been exposed to chemicals that are dangerous to the environment the risk must be assessed. The chemicals can accumulate in the rotor material. Take the necessary precautions to comply with applicable legal requirements and regulations.



WARNING!

If the rotor is to be cut in pieces, wear a suitable CE marked face mask selected and fitted in accordance with the applicable safety standards to protect from the dust.

10 Contact Munters

AUSTRIA	Munters GmbH Air Treatment Zweigniederlassung Wien	Eduard-Kittenberger-Gasse 56, Obj. 6 A-1235 Wien	Tel: +43 1 616 4298-92 51 luftentfeuchtung@munters.at www.munters.at
BELGIUM	Munters Belgium nv Air Treatment	Blarenberglaan 21c B-2800 Mechelen	Tel: +3215285611 service@muntersbelgium.be www.muntersbelgium.be
DENMARK	Munters A/S Air Treatment	Ryttermarken 4 DK-3520 Farum	Tel: +4544953355 info@munters.dk www.munters.dk
FINLAND	Munters Finland Oy Kuivaajamynti	Hakamaenuja 3 FI-01510 VANTAA	Tel: +358 207 768 230 laitemyynti@munters.fi www.munters.fi
FRANCE	Munters France SAS Air Treatment	106, Boulevard Héloïse F-95815 Argenteuil Cedex	Tel: +33 1 34 11 57 57 dh@munters.fr www.munters.fr
GERMANY	Munters GmbH Air Treatment-Zentrale	Hans-Duncker-Str. 8 D-21035 Hamburg	Tel: +49 (0) 40 879 690 - 0 mgd@munters.de www.munters.de
ITALY	Munters Italy S.p.A Air Treatment	Strada Piani 2 I-18027 Chiusavecchia IM	Tel: +39 0183 521377 marketing@munters.it www.munters.it
NETHERLANDS	Munters Vochtbeheersing	Energieweg 69 NL-2404 HE Alphen a/d Rijn	Tel: +31 172 43 32 31 vochtbeheersing@munters.nl www.munters.nl
POLAND	Munters Sp. z o.o. Oddzial w Polsce Air Treatment	ul. Swietojanska 55/11 81-391 Gdynia	Tel.: + 48 58 305 35 17 dh@munters.pl www.munters.com.pl
SPAIN	Munters Spain SA Air Treatment	Europa Epresarial. Edificio Londres. C/Playa de Liencres 2. 28230 Las Matas. Madrid	Tel: +34 91 640 09 02 marketing@munters.es www.munters.es
SWEDEN	Munters Europe AB Air Treatment	P O Box 1150 S-164 26 Kista	Tel: +46 8 626 63 00 avfuktning@munters.se www.munters.se
SWITZERLAND	Munters GmbH Air Treatment Zweigniederlassung Rümlang	Glattalstr. 501 CH-8153 Rümlang	Tel: +41 52 343 88 86 info.dh@munters.ch www.munters.ch
UNITED KINGDOM	Munters Ltd Air Treatment	Pathfinder Place 10 Ramsay Court Hinchingbrooke Business Park Huntingdon PE29 6FY Cambs	Tel: +44 1480 432 243 info@munters.co.uk www.munters.co.uk
AUSTRALIA	Tel: +61 288431588 dh.info@munters.com.au	MEXICO	Tel: +52 722 270 40 29 munters@munters.com.mx
BRAZIL	Tel: +55 11 5054 0150 www.munters.com.br	SINGAPORE	Tel: +65 6744 6828 singapore@muntersasia.com
CANADA	Tel: +1-800-843-5360 dhinfo@munters.com	SOUTH AFRICA	Tel: +27 11 997 2000 info@munters.co.za
CHINA	Tel: +86 10 804 18000 marketing@munters.cn	TURKEY	Tel: +90 216 548 14 44 info@muntersform.com
INDIA	Tel: +91 20 668 18 900 info@munters.in	UAE (Dubai)	Tel: +971 4 881 3026 middle.east@munters.com
JAPAN	Tel: +81 3 5970 0021 mkk@munters.jp	USA	Tel: +1-800-843-5360 dhinfo@munters.com
KOREA	Tel: +82 2 761 8701 munters@munters.kr		

www.munters.com

