

# Instruction Manual

## Munters Drive\* G2 Rotor Replacement Kit for ATS74 and CX74 Fans

\*Protected by U.S. Patent No. 20230031171A1,  
11632932B2 and other Patents Pending

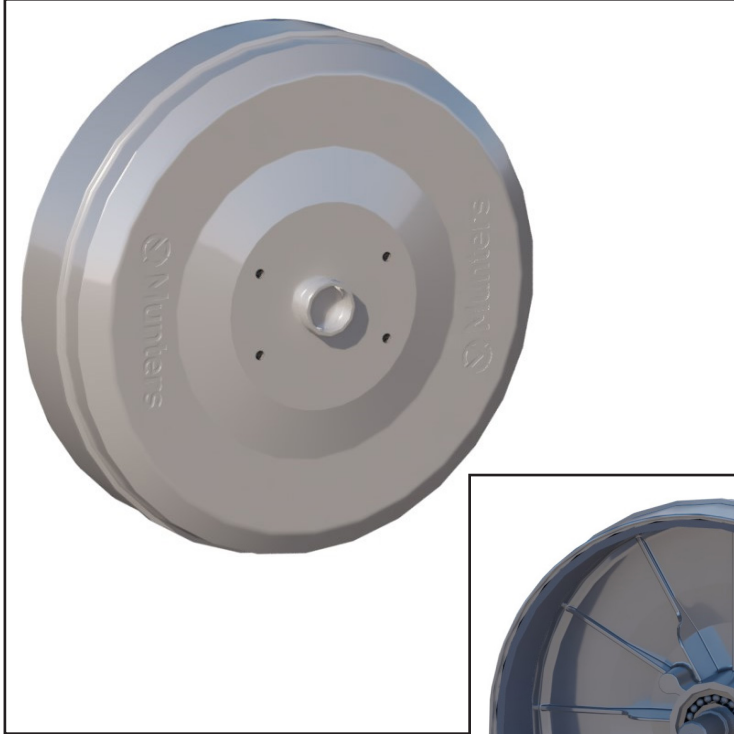

Front View

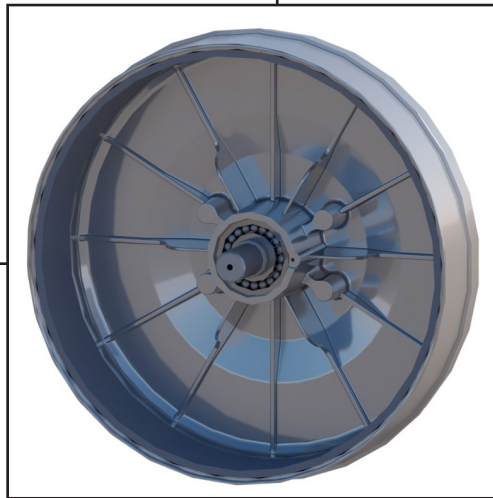

Rear View

## Munters Drive G2

### Rotor Replacement Kit

Models: FM1461



# Munters Drive Rotor Replacement Kit

## Instructions for Use and Maintenance

### Thank You:

Thank you for purchasing a Munters Drive Rotor replacement kit. Munters equipment is designed to be the highest performing, highest quality equipment you can buy. With the proper installation and maintenance it will provide many years of service.

### Please Note:

To achieve maximum performance and insure long life from your Munters product it is essential that it be installed and maintained properly. Please read all instructions carefully before beginning installation.

### Warranty:

For Warranty claims information see the "Warranty Claims and Return Policy" form QM1021 available from the [Munters Corporation office at 1-800-227-2376 or by e-mail at aghort.info@munters.com](mailto:aghort.info@munters.com).

### Conditions and Limitations:

- Products and Systems involved in a warranty claim under the "Warranty Claims and Return Policy" shall have been properly installed, maintained and operated under competent supervision, according to the instructions provided by Munters Corporation.
- Malfunction or failure resulting from misuse, abuse, negligence, alteration, accident or lack of proper installation or maintenance shall not be considered a defect under the Warranty.

# Index

Chapters	Page
<a href="#">1. Unpacking the Equipment</a>	4
<a href="#">1.1 Parts List</a>	4
<a href="#">2. Installation Instructions</a>	5
<a href="#">2.1 G2 Rotor Replacement for Atlas 74 Fan</a>	5
<a href="#">2.2 G2 Rotor Replacement for CX74 Fan</a>	16

# Unpacking the Equipment

# 1.

## 1.1 Parts List

Before beginning installation, check the overall condition of the equipment. Remove packing materials, and examine all components for signs of shipping damage. Any shipping damage is the customer's responsibility and should be reported immediately to your freight carrier.

Each FM1461 Munters Drive Rotor Kit Includes:

- 1 - Munters Drive G2 Rotor
- 1 - Hardware Package As Follows:

HP2751 - Hardware Package for MD Rotor Kit

ID	Qty.	Cat. No.	Description
[A]	4	KS1959	M8-1.25 x 20mm, SRRTD HX, Bolt, ZP
[C]	4	KS1162	M6-1.0 x 40mm, HX Washer HD Bolt, ZP
[D]	1	KN1860	M25-2.0 x 10mm Hex Nut, ZP

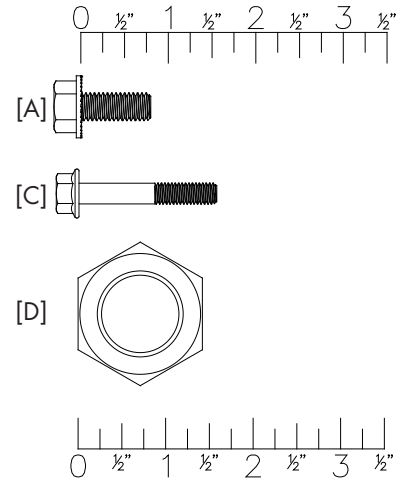

If you are installing this Rotor Kit on an Atlas 74 Exhaust Fan, proceed to [Page 5, Step 1](#).  
 If you are installing this Rotor Kit on a CX74 Circulation Fan, proceed to [Page 16, Step 13](#).  
 See Figures below.

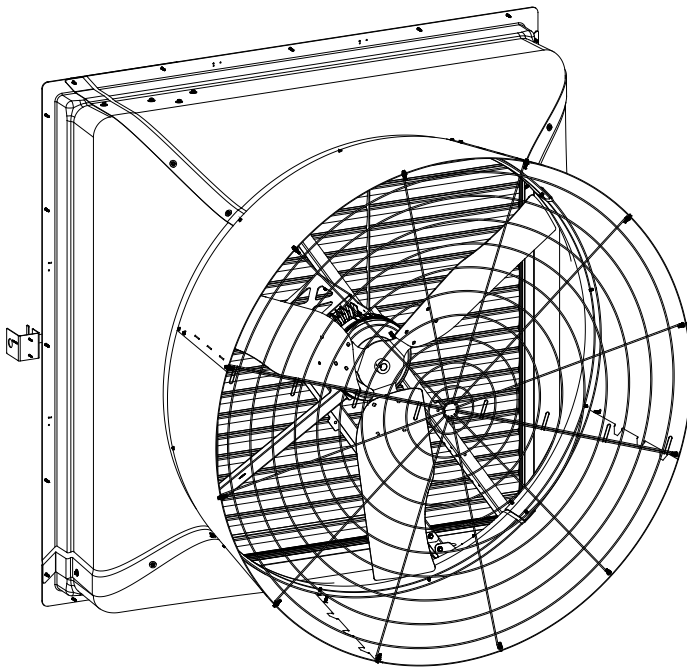

Atlas 74 Exhaust Fan  
 Proceed to Page 5, Step 1

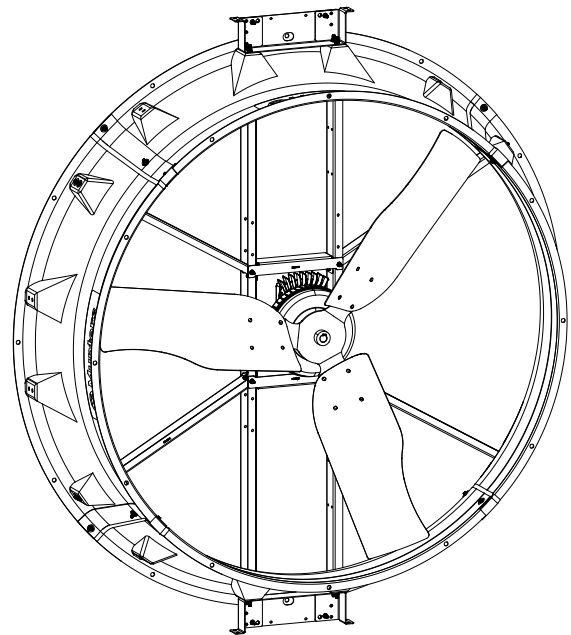

CX74 Circulation Fan  
 Proceed to Page 16, Step 13

## 2.1 Rotor Replacement for Atlas74 Fan

### Step 1

Disconnect power from fan before continuing. Remove the shutter from the back of the fan and set safely aside to be reinstalled later. *See Figure 1.*

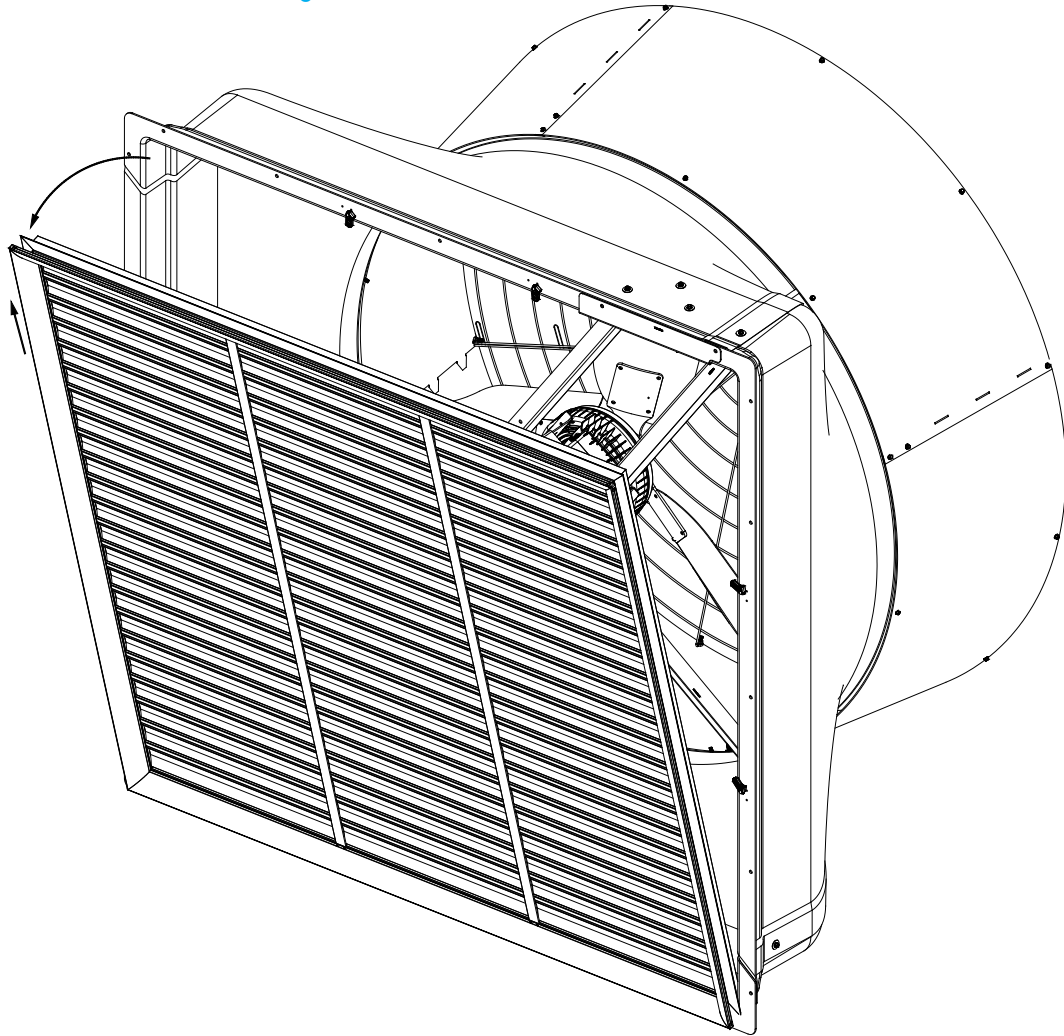

Figure 1

**Step 2**

Loosen the set screw holding the Prop on the Prop Adapter. Carefully remove the Prop from the Prop Adapter and carefully set it into the cone leaning against the outlet guard to be reinstalled later. A gear puller may need to be used. Remove Key from Prop Adapter and keep with prop to be reused later. [See Figure 2.](#)

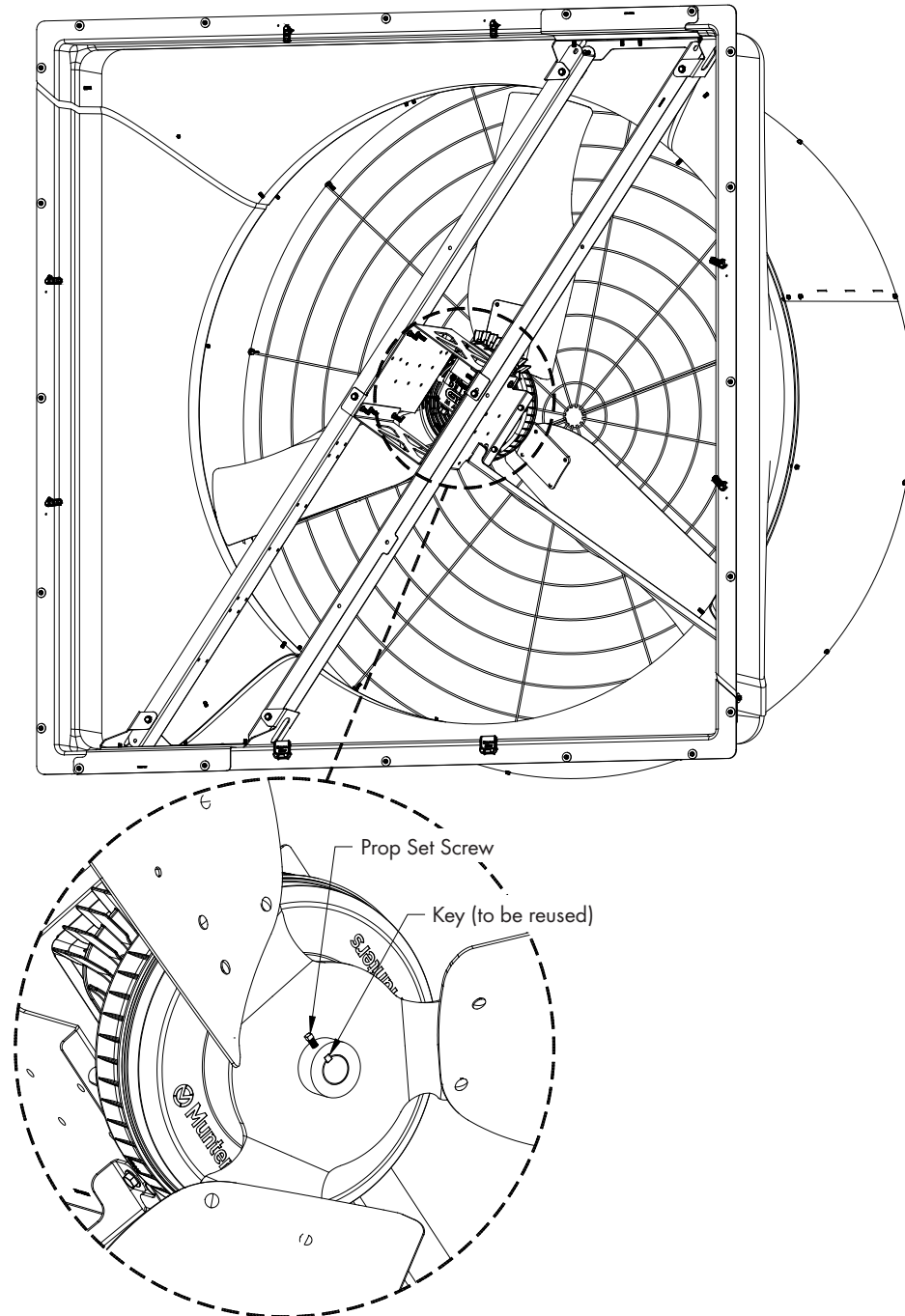

Figure 2

**Step 3**

Remove the (4) Bolts holding the Heat Sink with Control Box to the back of the Munters Drive Motor and carefully set the Heat Sink with Control Box in the fan. See Figure 3. Discard the (4) bolts removed.

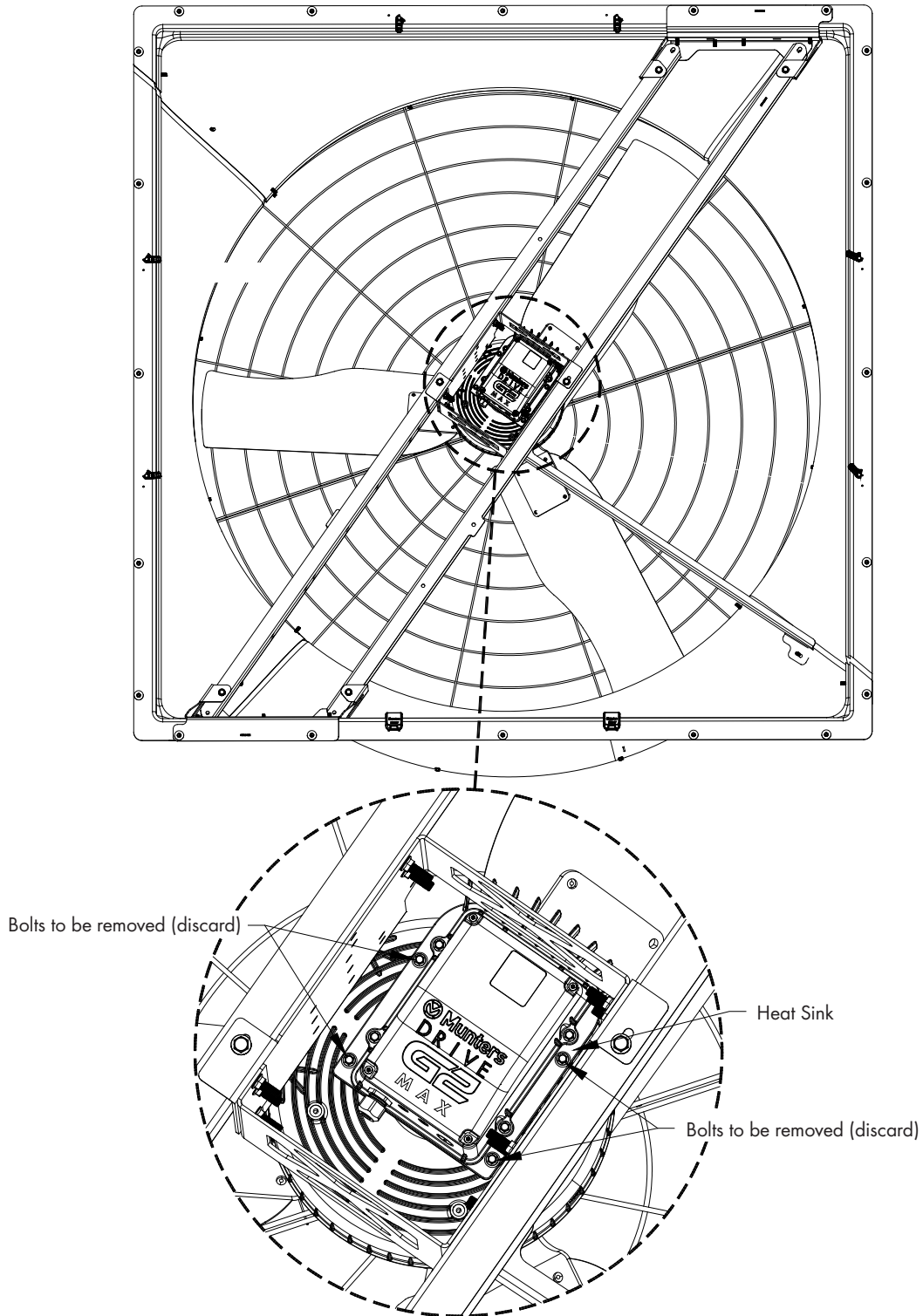

Figure 3

Step 4

Remove the Phillips Screw holding the Black Plastic Cover Cap and remove the Cover Cap from the large Hex Nut. Save the Phillips Screw and Cap for reuse. Using a 36mm Socket, remove the M25 Hex Nut from back of the Munters Drive Motor and discard. See Figure 4.

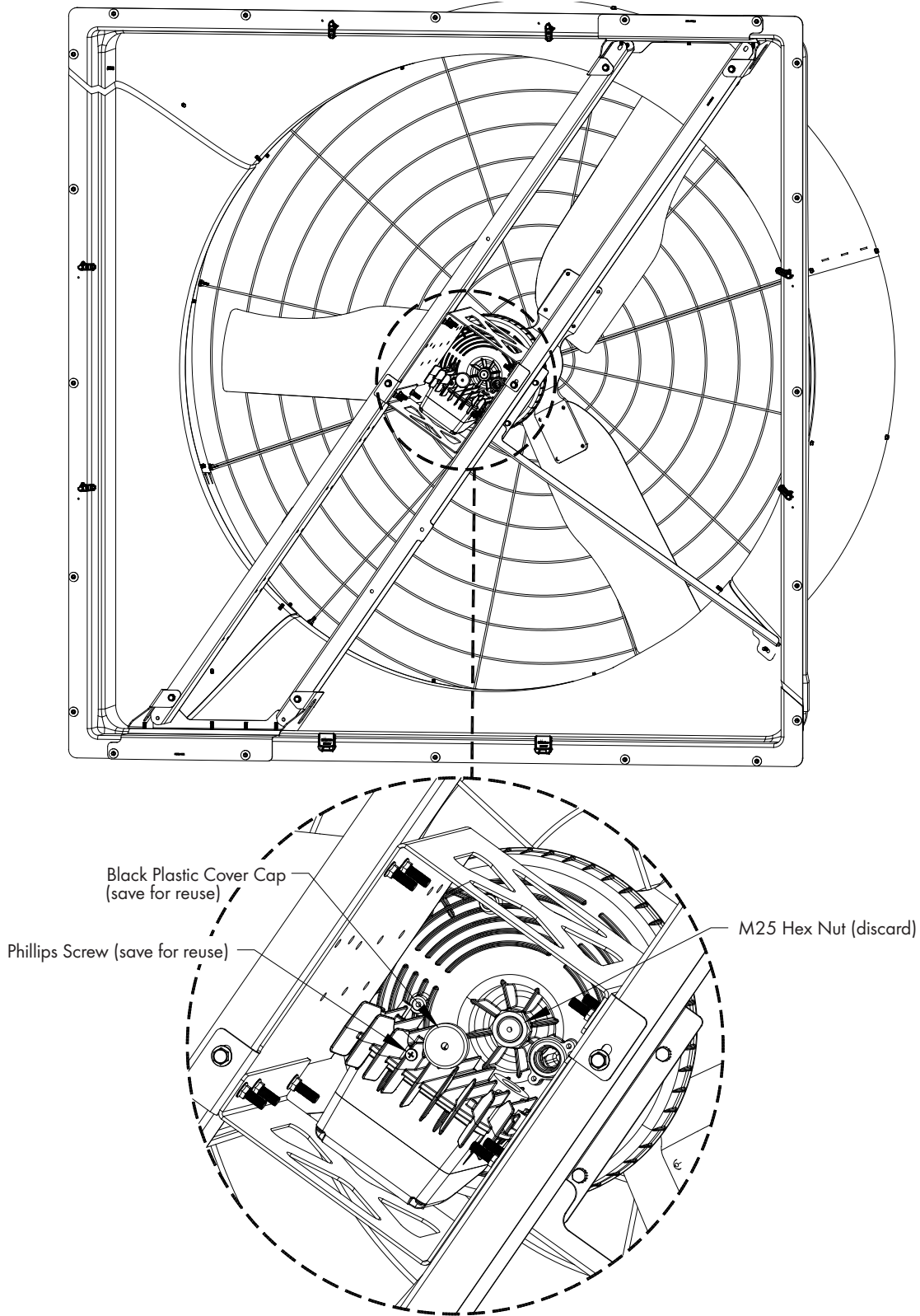

Figure 4



**Step 5**

Using the Prop Adapter on the front of the Munters Drive Motor as a hand hold and using a large screw driver on the shaft, pull/push hard straight forward until the Rotor comes off the Munters Drive Motor. Be careful not to get fingers pinched between the Rotor and Motor. See Figure 5.

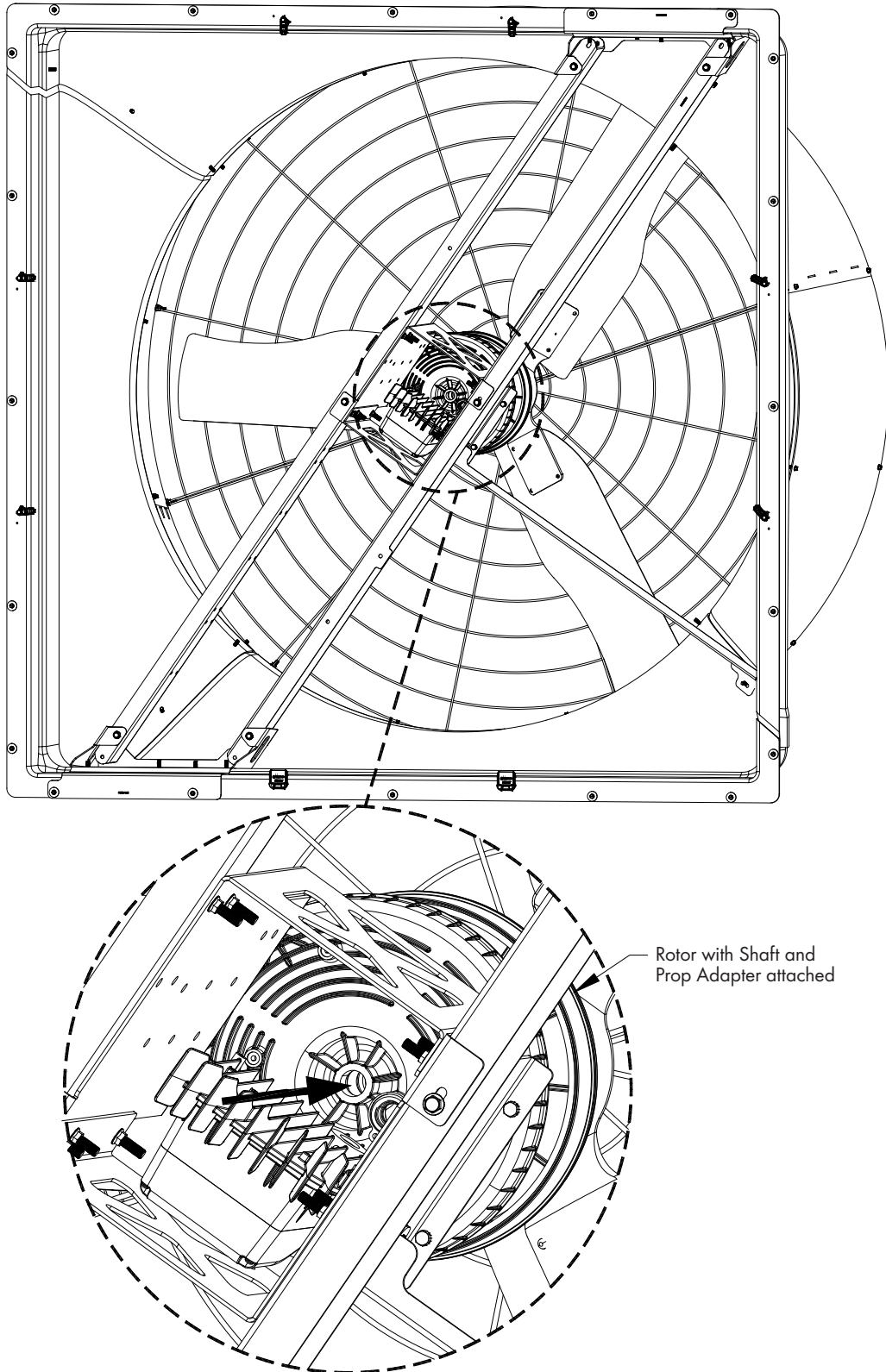

Figure 5

**Step 6**

Remove the (4) Bolts and Star Washers holding the Prop Adapter to the Rotor. Save the Prop Adapter for reuse, but discard the existing bolts and washers. See Figure 6.

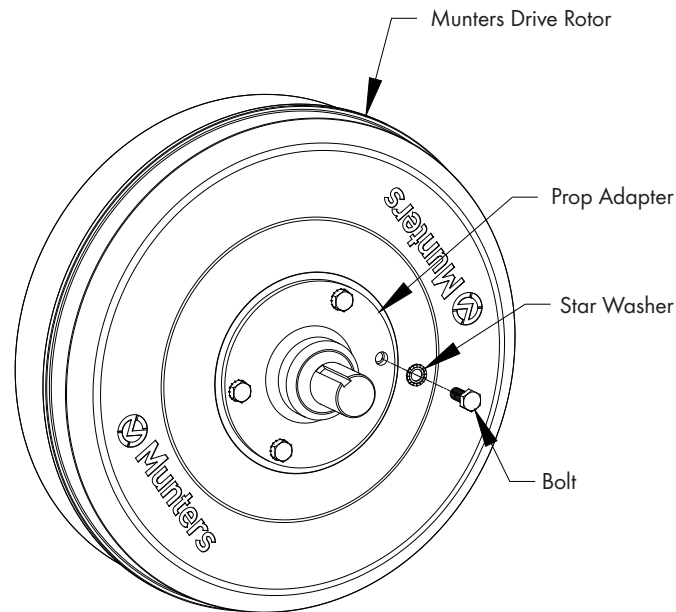

Figure 6

**Step 7**

Attach the Prop Adapter removed in previous step to new Munters Drive Rotor using (4) Bolts [A]. Tighten Bolts to 60 in-lbs. [6.8 Nm] of torque. See Figure 7.

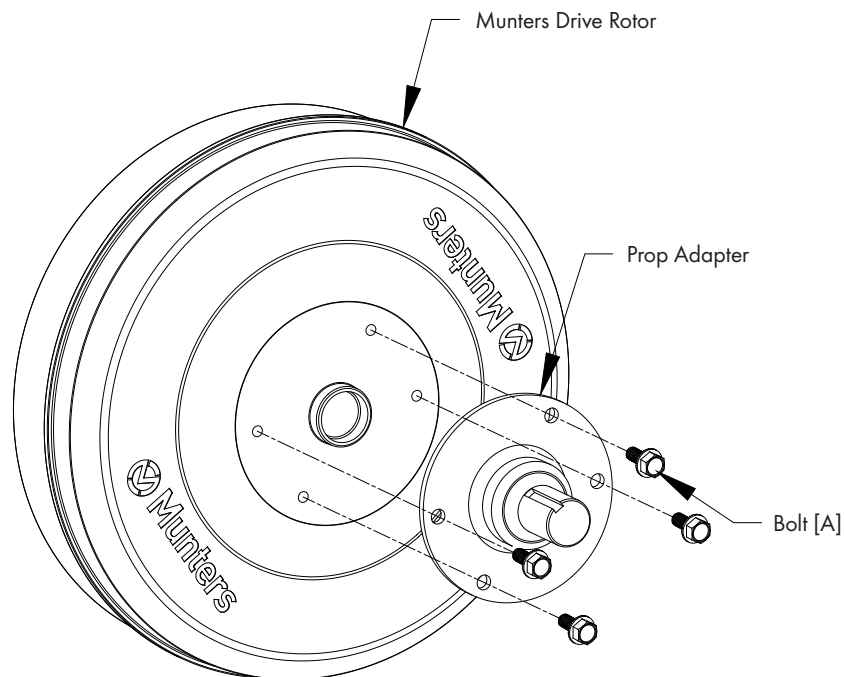
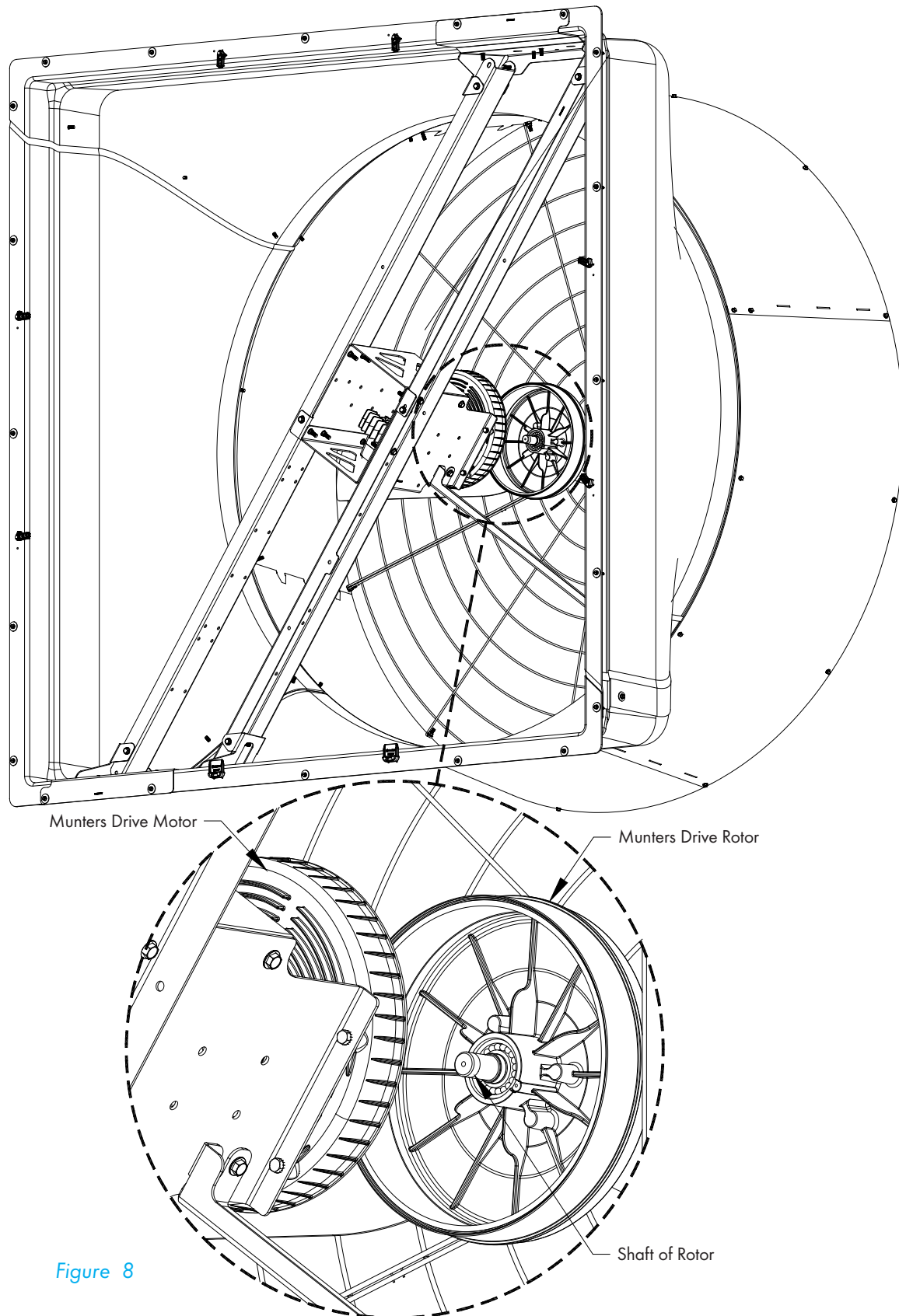

Figure 7

**Step 8**

Using the Prop Adapter as a hand hold insert the New Rotor back into the Motor, taking care to align the shaft with the hole in the back of the Motor and not allowing the New Rotor to slam into place. Be careful not to get fingers pinched between Rotor and Motor. [See Figure 8.](#)



**Figure 8**

## Step 9

Secure New Rotor with Prop Adapter to Motor with new M25 Hex Nut [D] and tighten to 210 ft-lbs. [285 N-m] torque. Then replace Black Cover Cap over M25 Hex Nut and secure in place with Phillips Screw removed in Step 4. See Figure 9. Make sure the O-Ring is seated in the groove around the Wiring Entrance into the Motor.

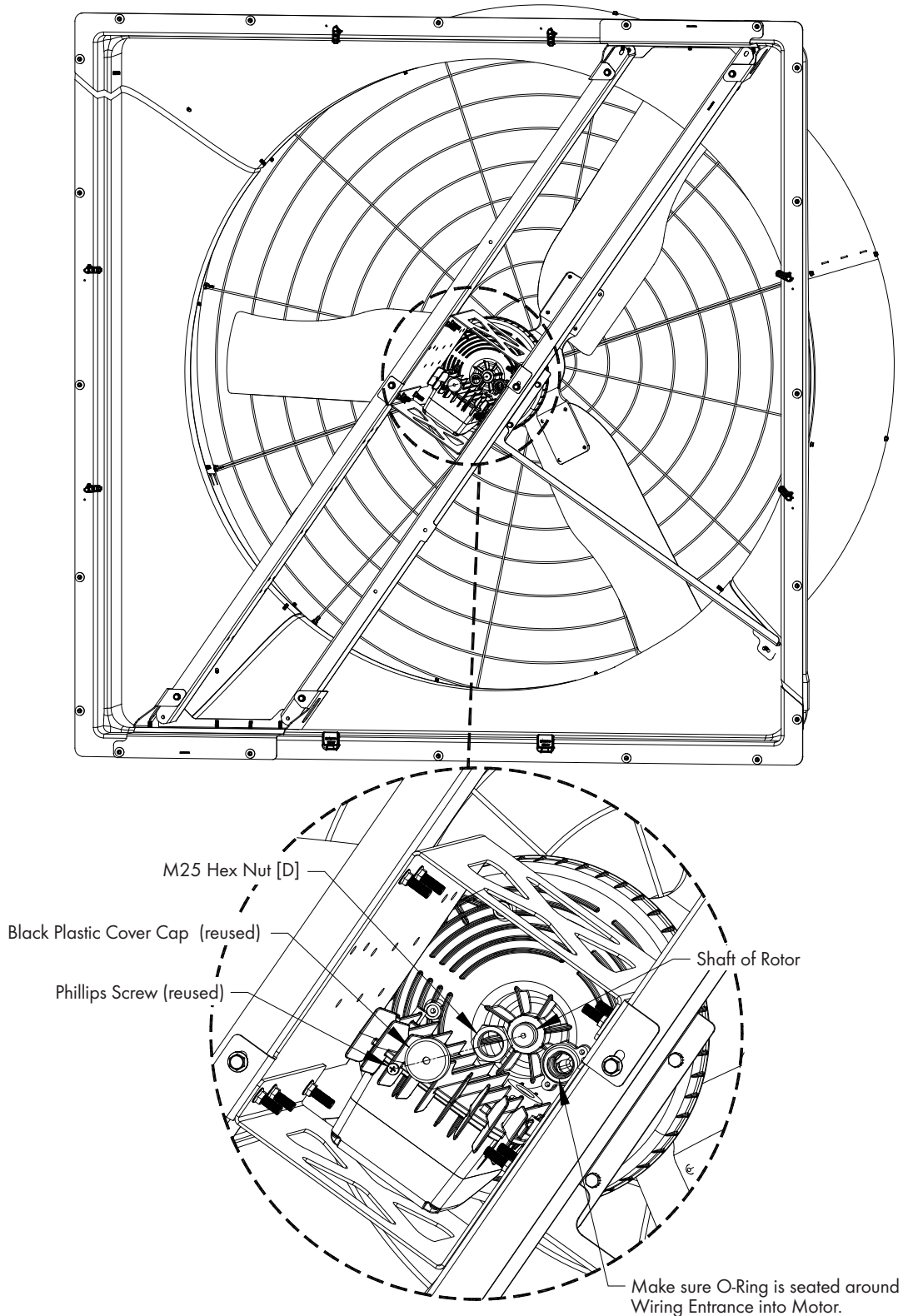

Figure 9

**Step 10**

Align the Wiring Entrance and (4) mounting holes in the Heat Sink with the Wiring Entrance and (4) mounting holes in the back of the Munters Drive Motor and secure in place with (4) Bolts [C]. Tighten Bolts to 60 in-lbs. [6.8 N-m] of torque. [See Figure 10.](#)

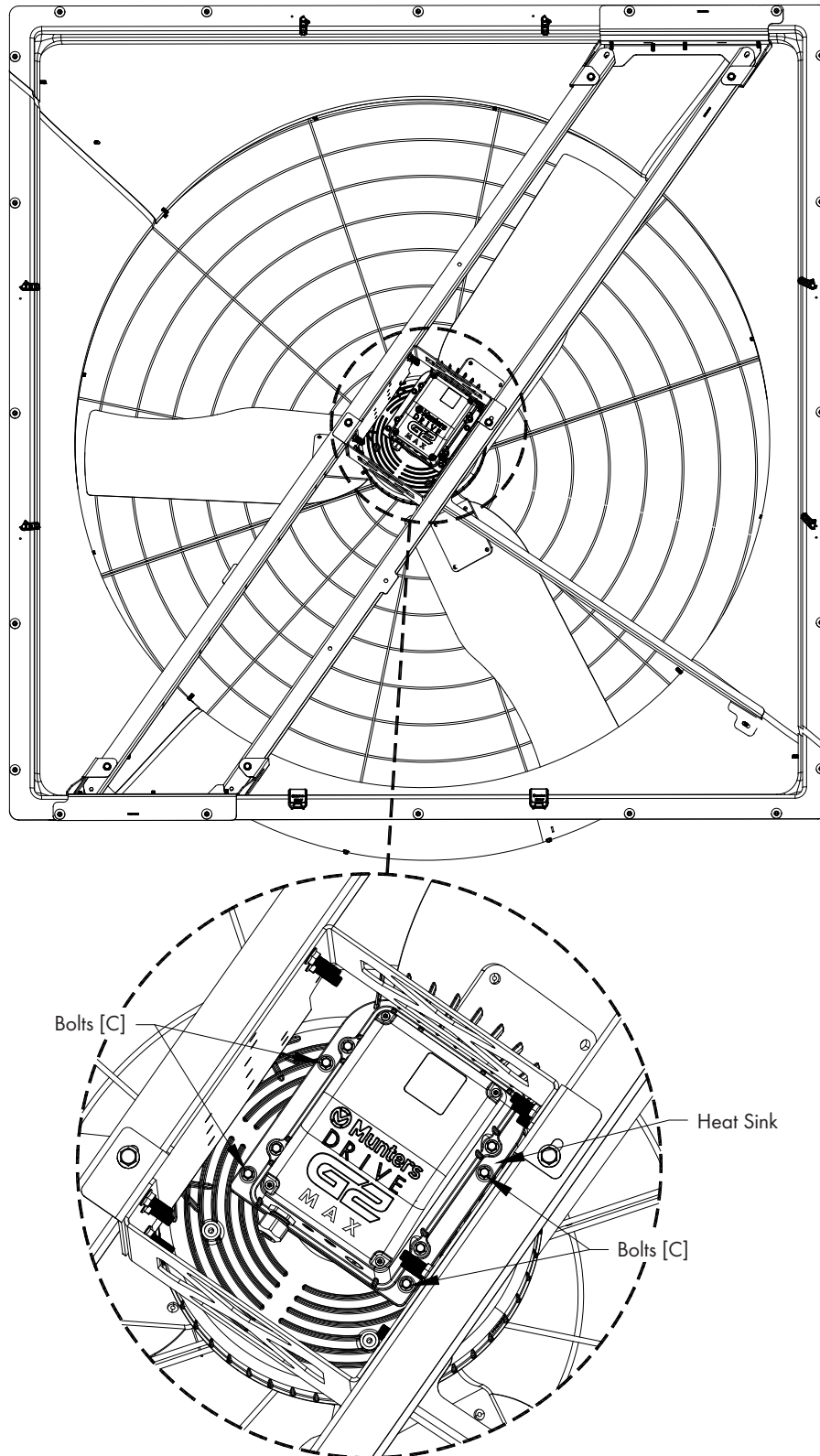

Figure 10

Step 11

Reinstall propeller onto the reinstalled Prop Adapter, replacing the key removed in Step 2. Tighten the Set Screw to 80 in-lbs. [9.0 Nm] of torque. See Figure 11.

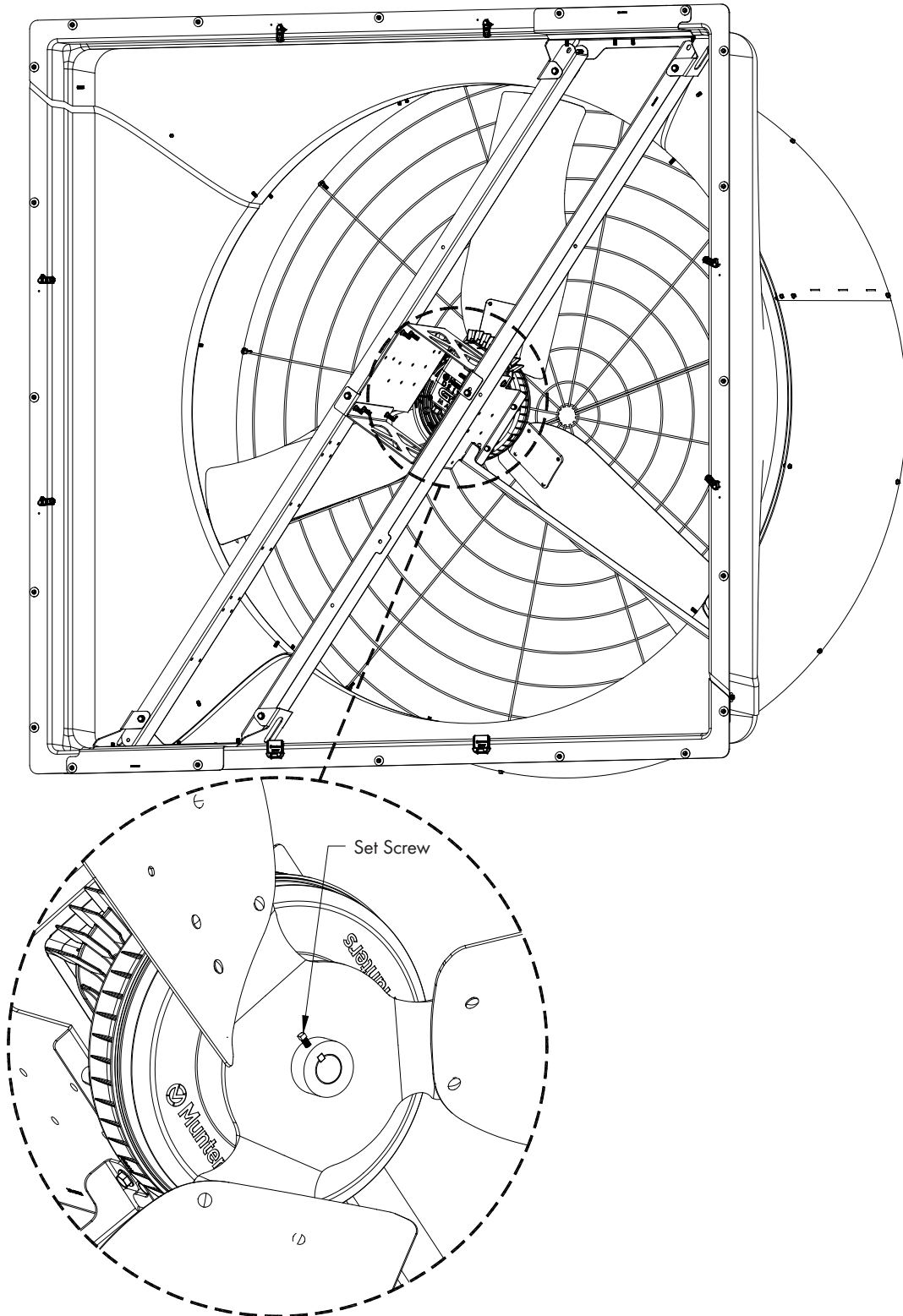

Figure 11

**Step 12**

Reinstall the shutter in the back of the fan and secure in place with the shutter clips. [See Figure 12.](#) Reconnect the power to the fan and make sure the fan operates properly.

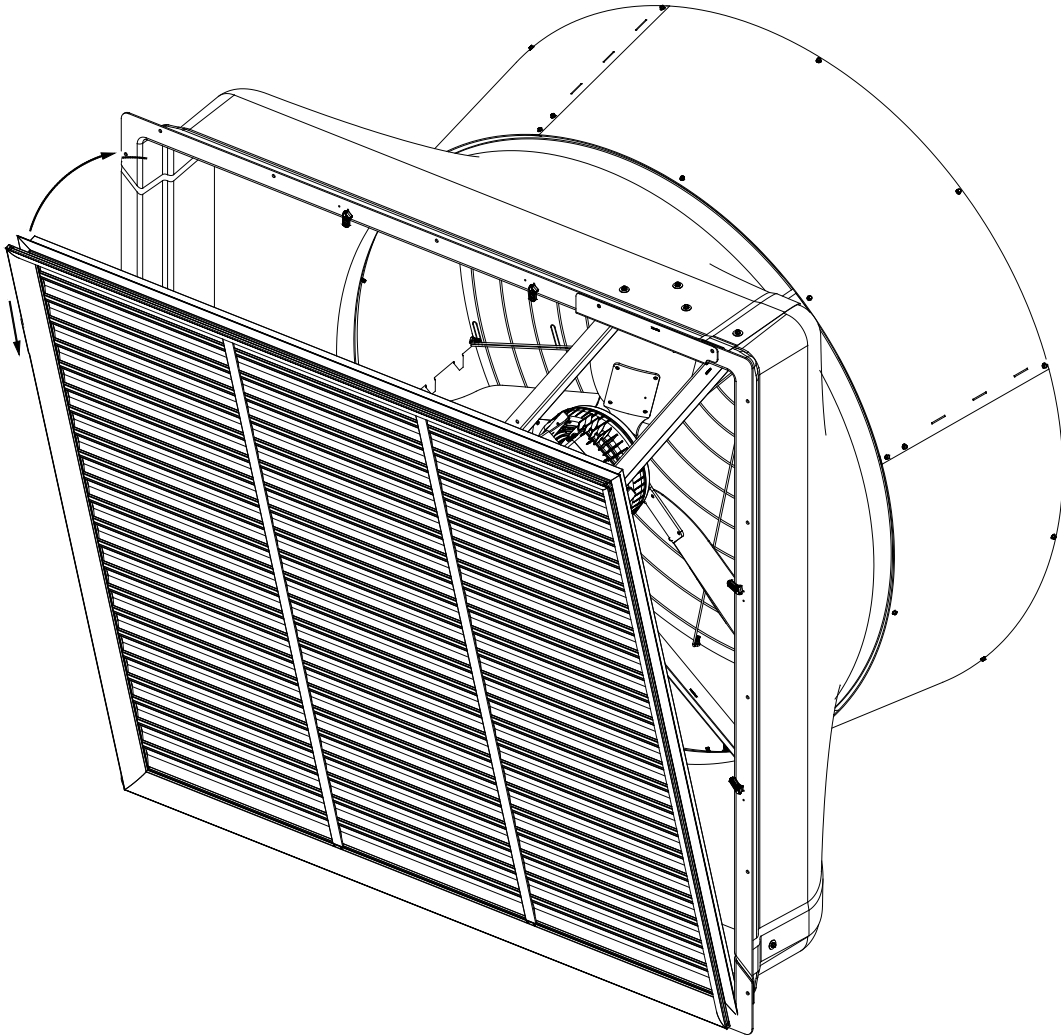

Figure 12

## 2.2 MD2 Replacement for CX74 Fan

### Step 13

Disconnect power from fan before continuing. Remove the front and rear guards from the fan and set safely aside to be reinstalled later. [See Figure 13.](#)

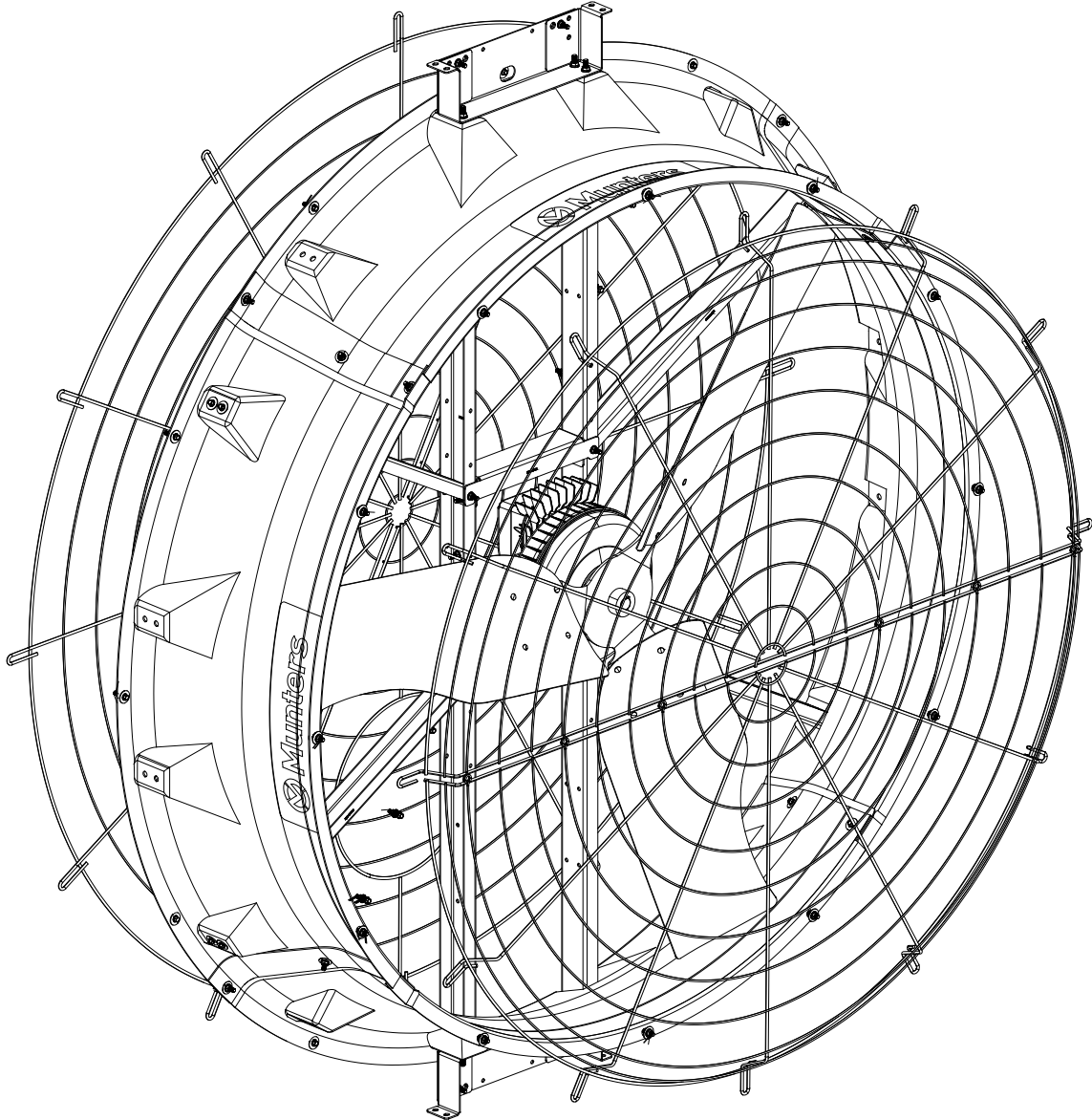

Figure 13



**Step 14**

Loosen the Set Screw holding the propeller to the shaft. Carefully remove the propeller from the fan and set safely aside to be reinstalled later. A gear puller or prop puller may need to be used.

See Figure 14. Remove Key from Prop Adapter and keep with prop to be reused later.

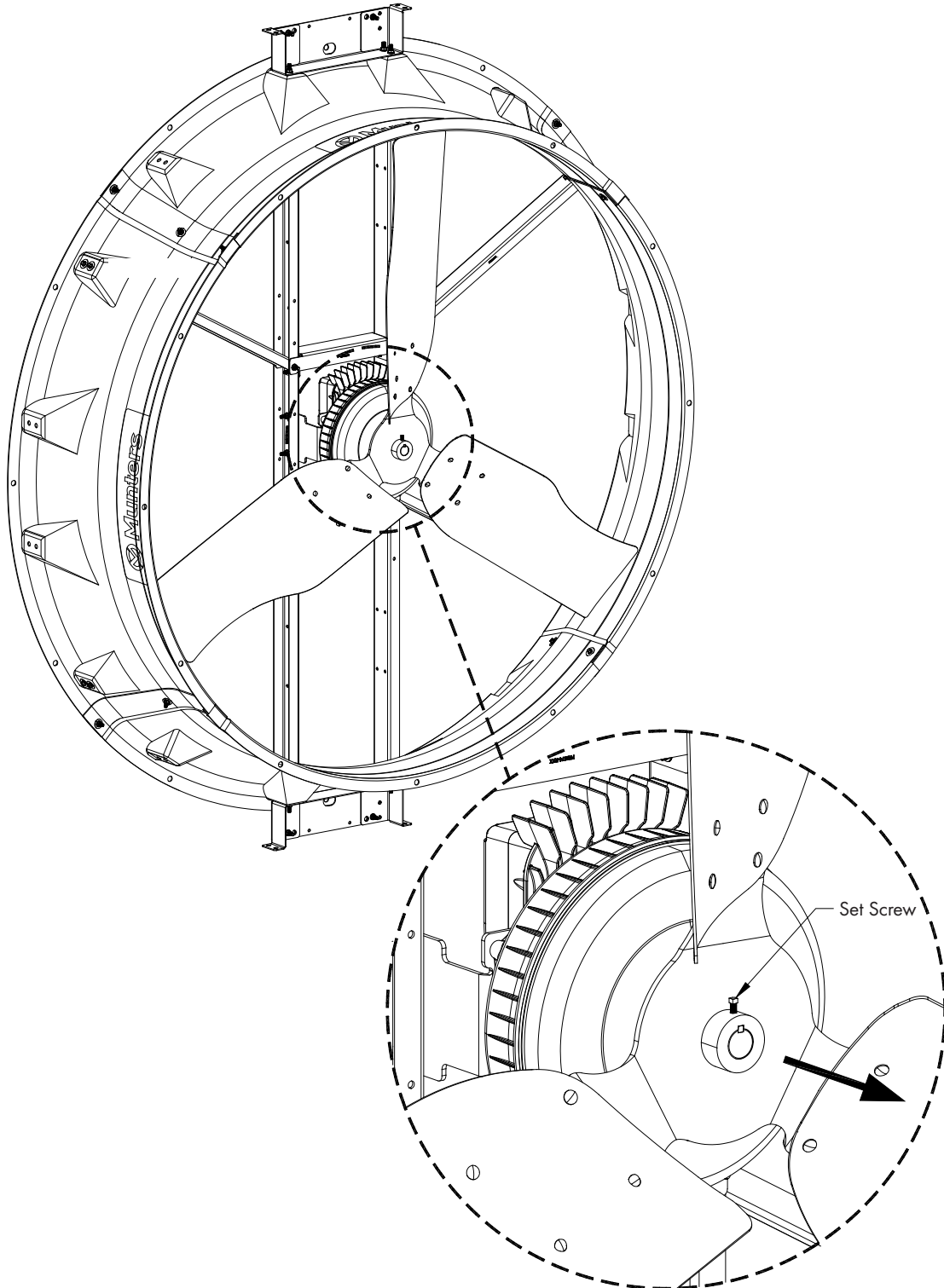

Figure 14

Step 15

Remove the (4) Bolts holding the Heat Sink with Control Box to the back of the Munters Drive Motor and carefully set the Heat Sink with Control Box in the fan. See Figure 15. Discard the (4) bolts removed.

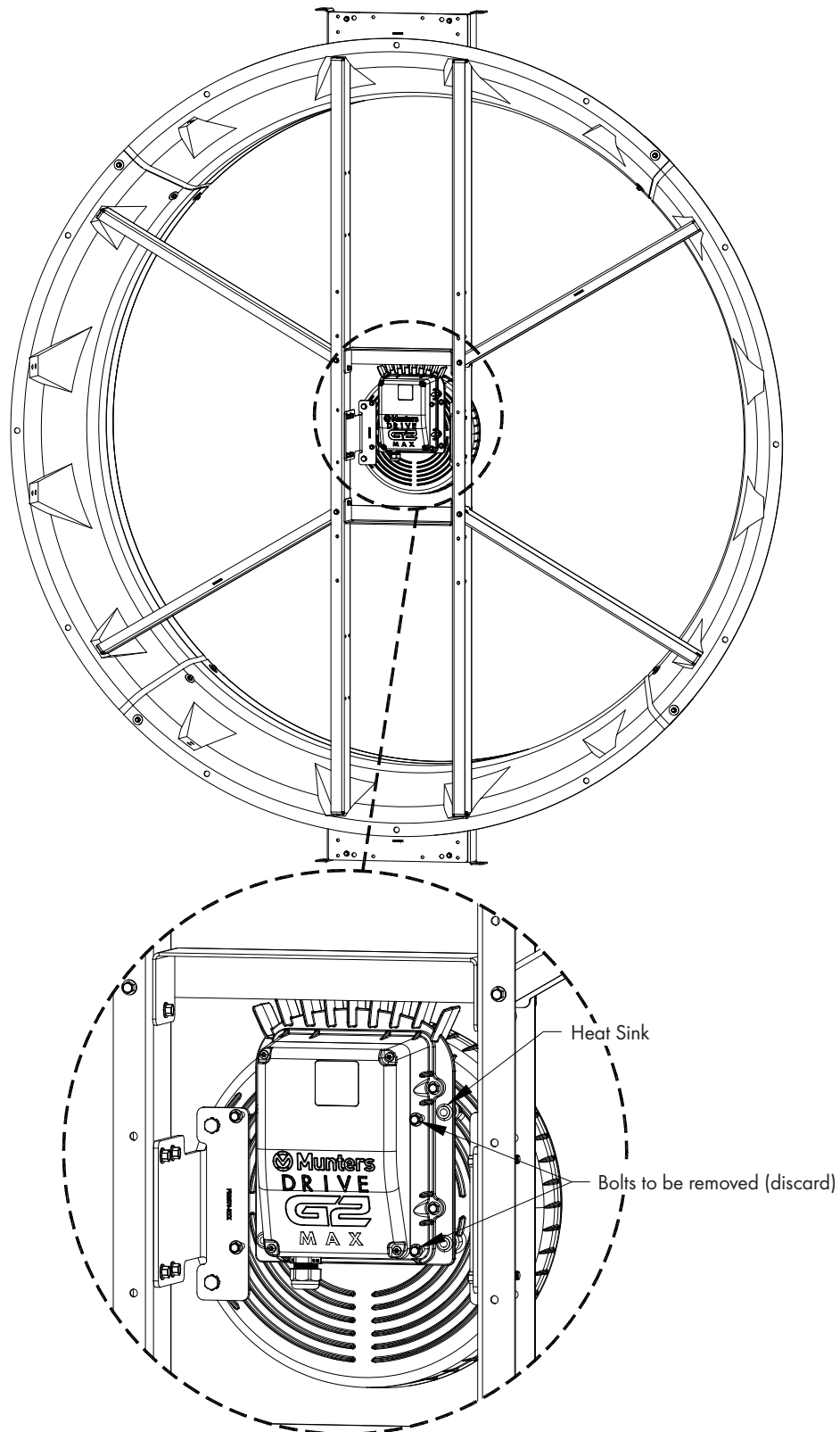

Figure 15

**Step 16**

Remove the Phillips Screw holding the Black Plastic Cover Cap and remove the Cover Cap from the large Hex Nut. Save the Phillips Screw and Cap for reuse. Using a 36mm Socket, remove the M25 Hex Nut from back of the Munters Drive Motor and discard. See Figure 16.

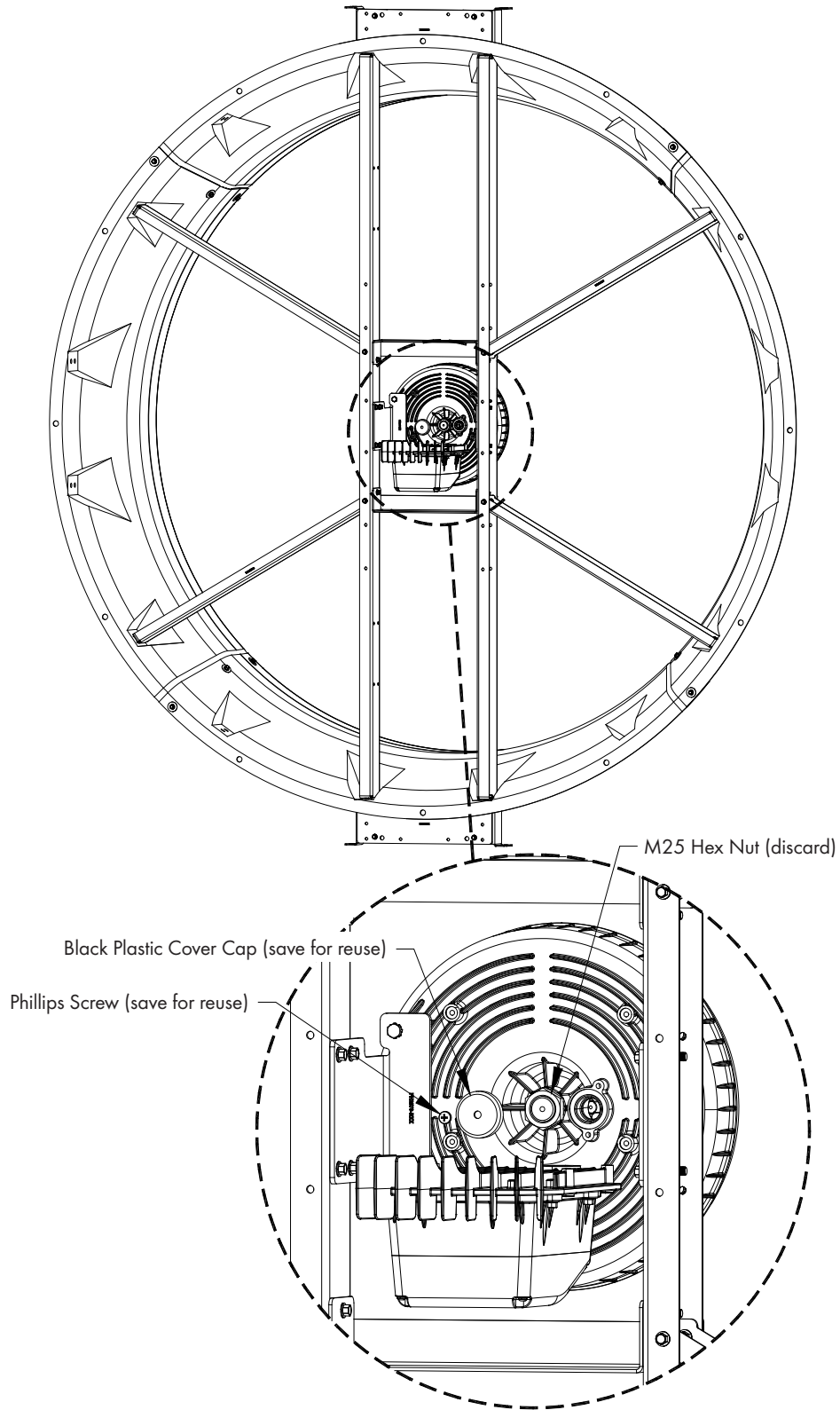
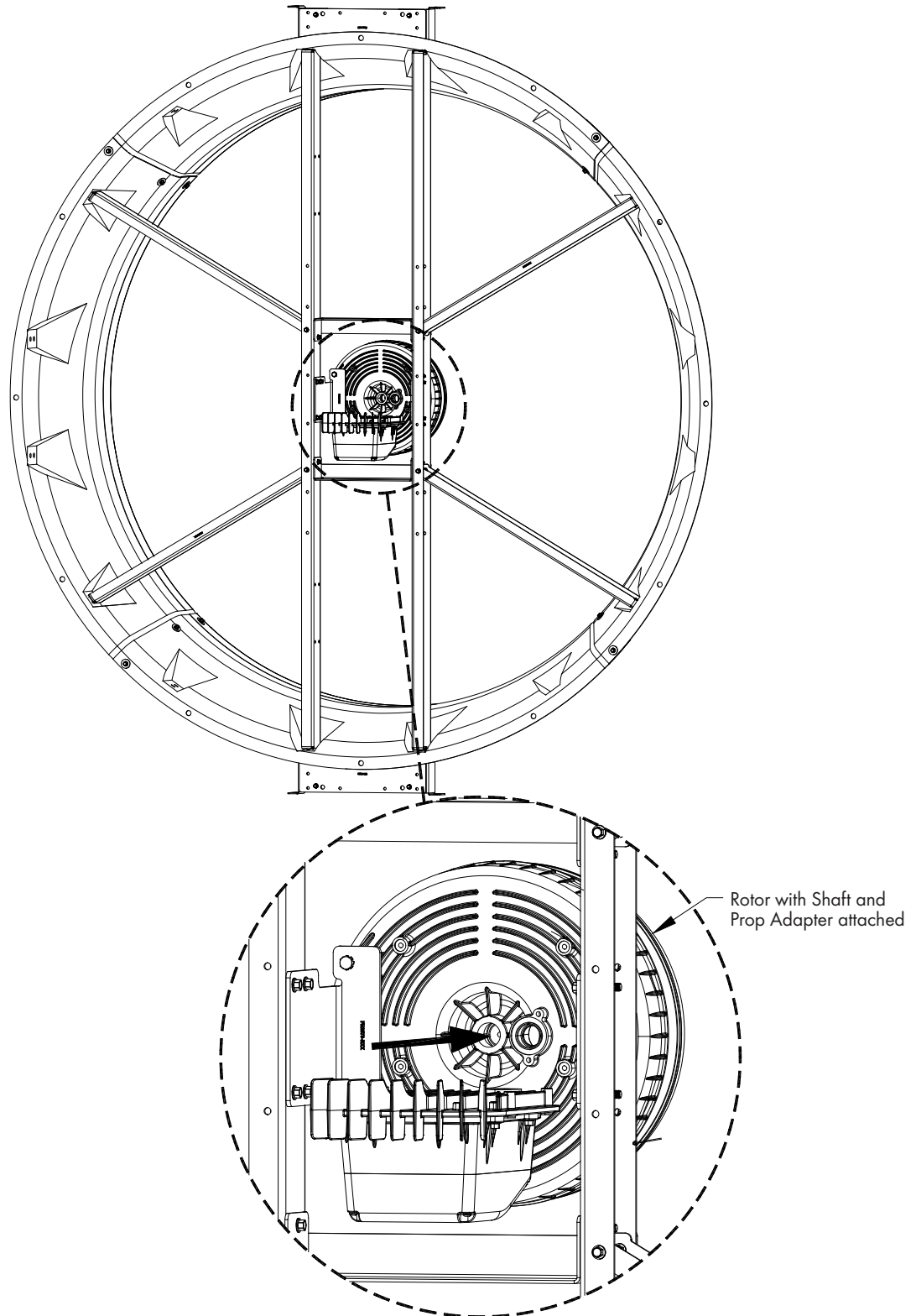

Figure 16

**Step 17**

Using the Prop Adapter on the front of the Munters Drive Motor as a hand hold and using a large screw driver on the shaft, pull/push hard straight forward until the Rotor comes off the Munters Drive Motor. Be careful not to get fingers pinched between the Rotor and Motor. [See Figure 17.](#)



**Figure 17**

**Step 18**

Remove the (4) Bolts and Star Washers holding the Prop Adapter to the Rotor. Save the Prop Adapter for reuse, but discard the existing bolts and washers. See Figure 18.

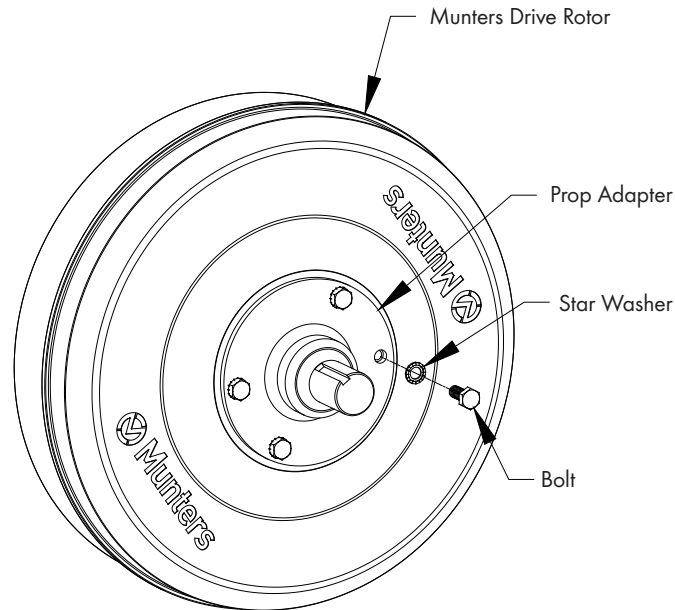

Figure 18

**Step 19**

Attach the Prop Adapter removed in previous step to new Munters Drive Rotor using (4) Bolts [A]. Tighten Bolts to 60 in-lbs. [6.8 Nm] of torque. See Figure 19.

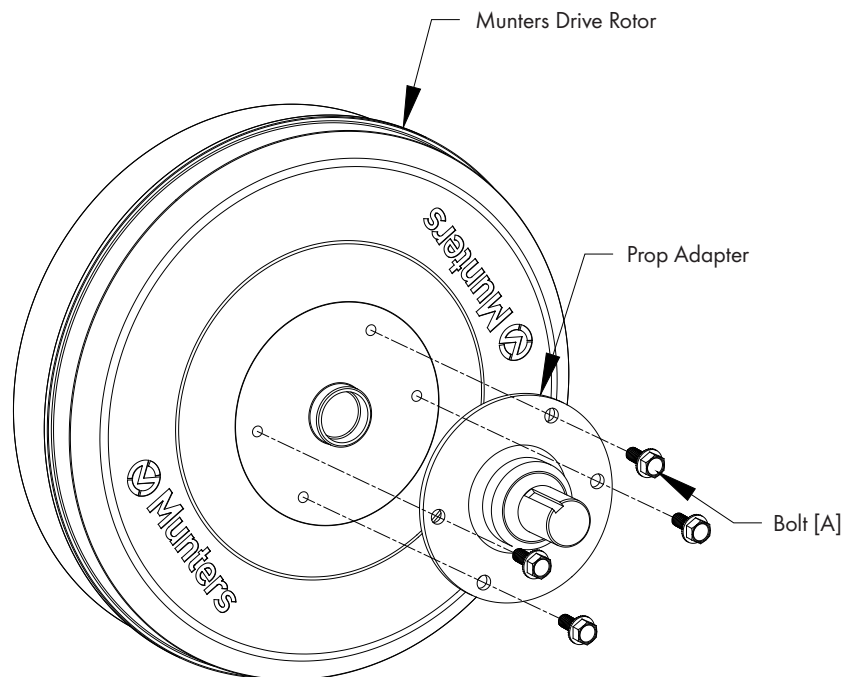

Figure 19

Step 20

Using the Prop Adapter as a hand hold insert the New Rotor back into the Motor, taking care to align the shaft with the hole in the back of the Motor and not allowing the New Rotor to slam into place. Be careful not to get fingers pinched between Rotor and Motor. See Figure 20.

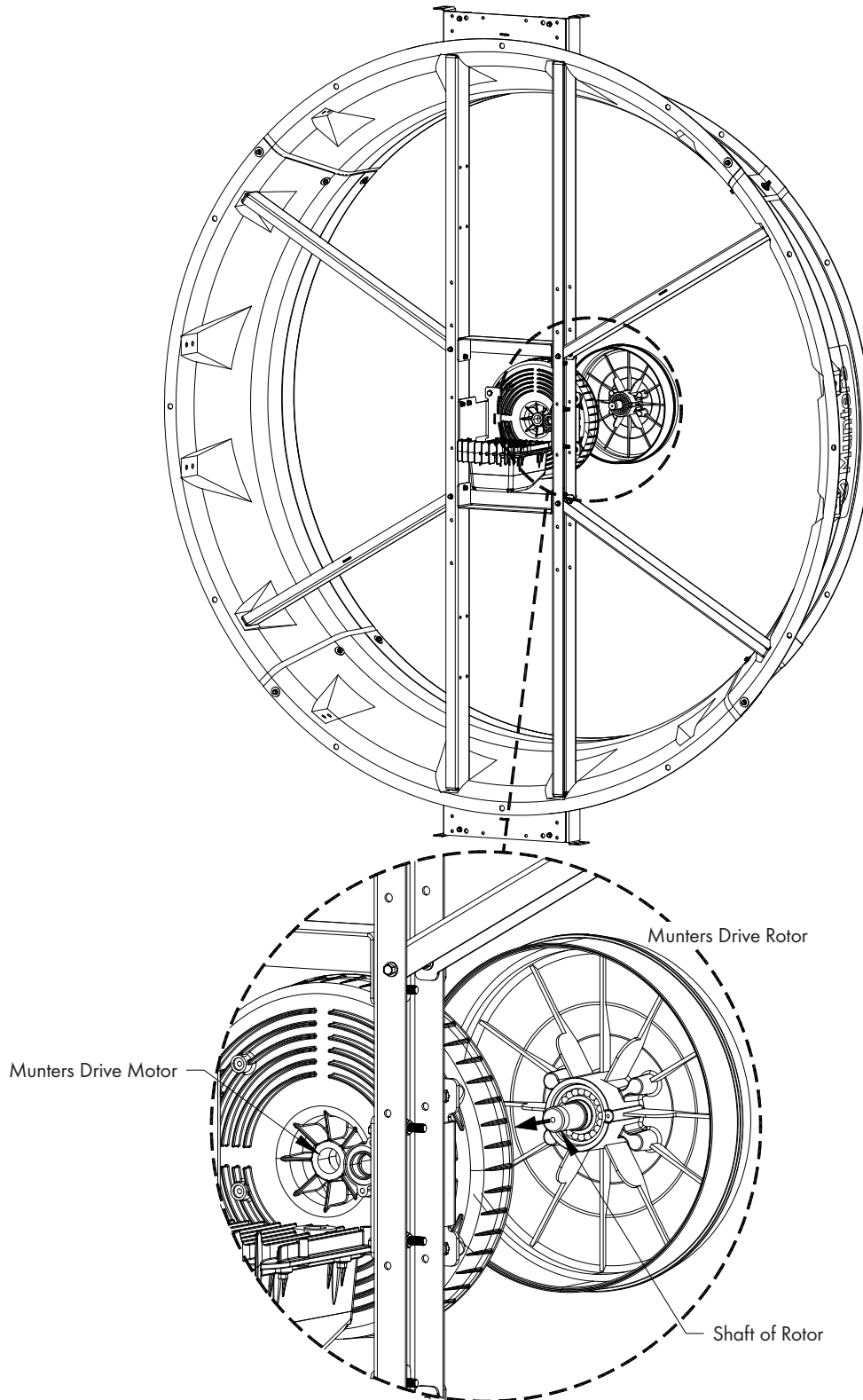

Figure 20

## Step 21

Secure New Rotor with Prop Adapter to Motor with new M25 Hex Nut [D] and tighten to 210 ft-lbs. [285 N-m] torque. Then replace Black Cover Cap over M25 Hex Nut and secure in place with Phillips Screw removed in Step 4. See Figure 21. Make sure the O-Ring is seated in the groove around the Wiring Entrance into the Motor.

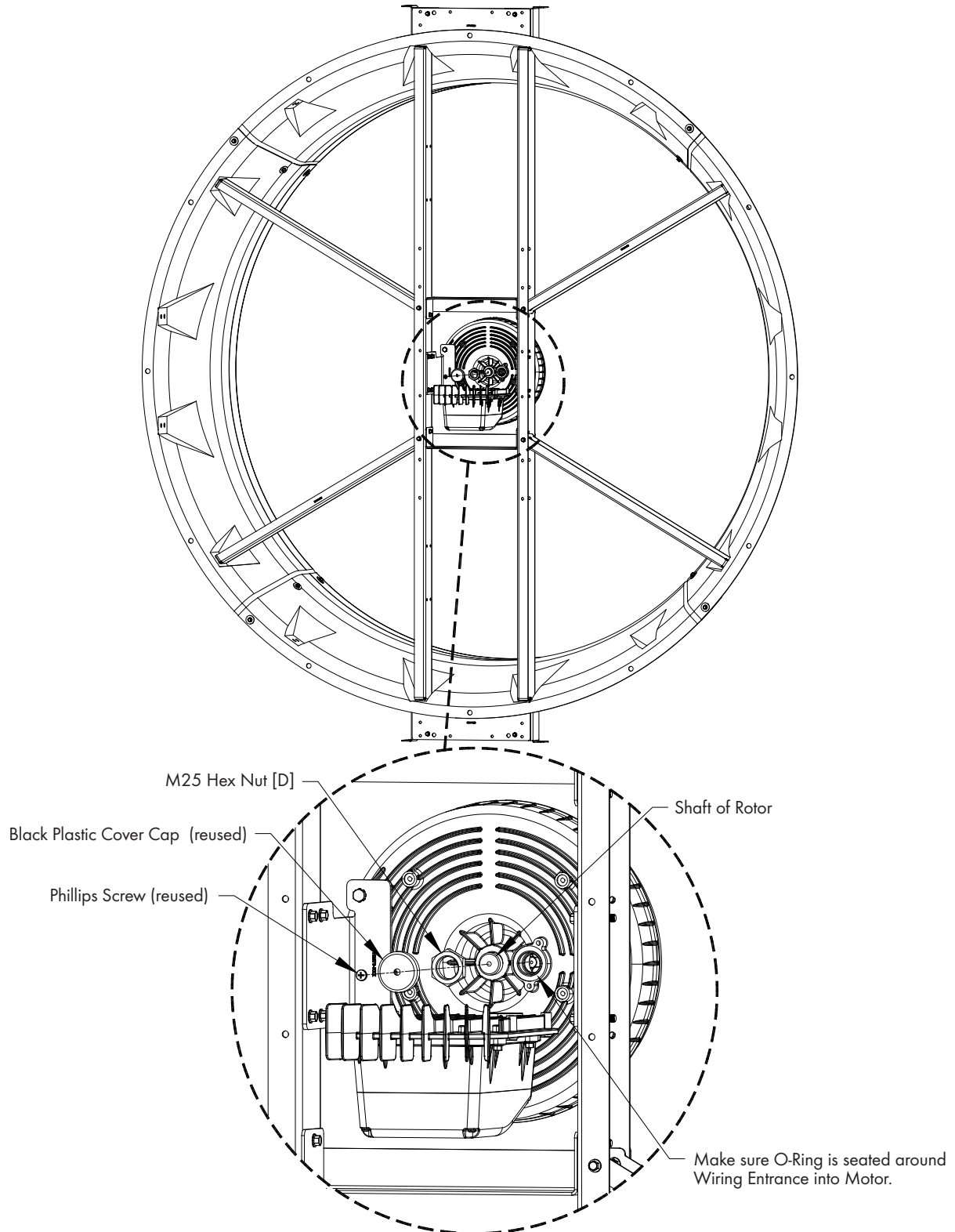

Figure 21

**Step 22**

Align the Wiring Entrance and (4) mounting holes in the Heat Sink with the Wiring Entrance and (4) mounting holes in the back of the Munters Drive Motor and secure in place with (4) Bolts [C]. Tighten Bolts to 60 in-lbs. [6.8 N-m] of torque. See Figure 22.

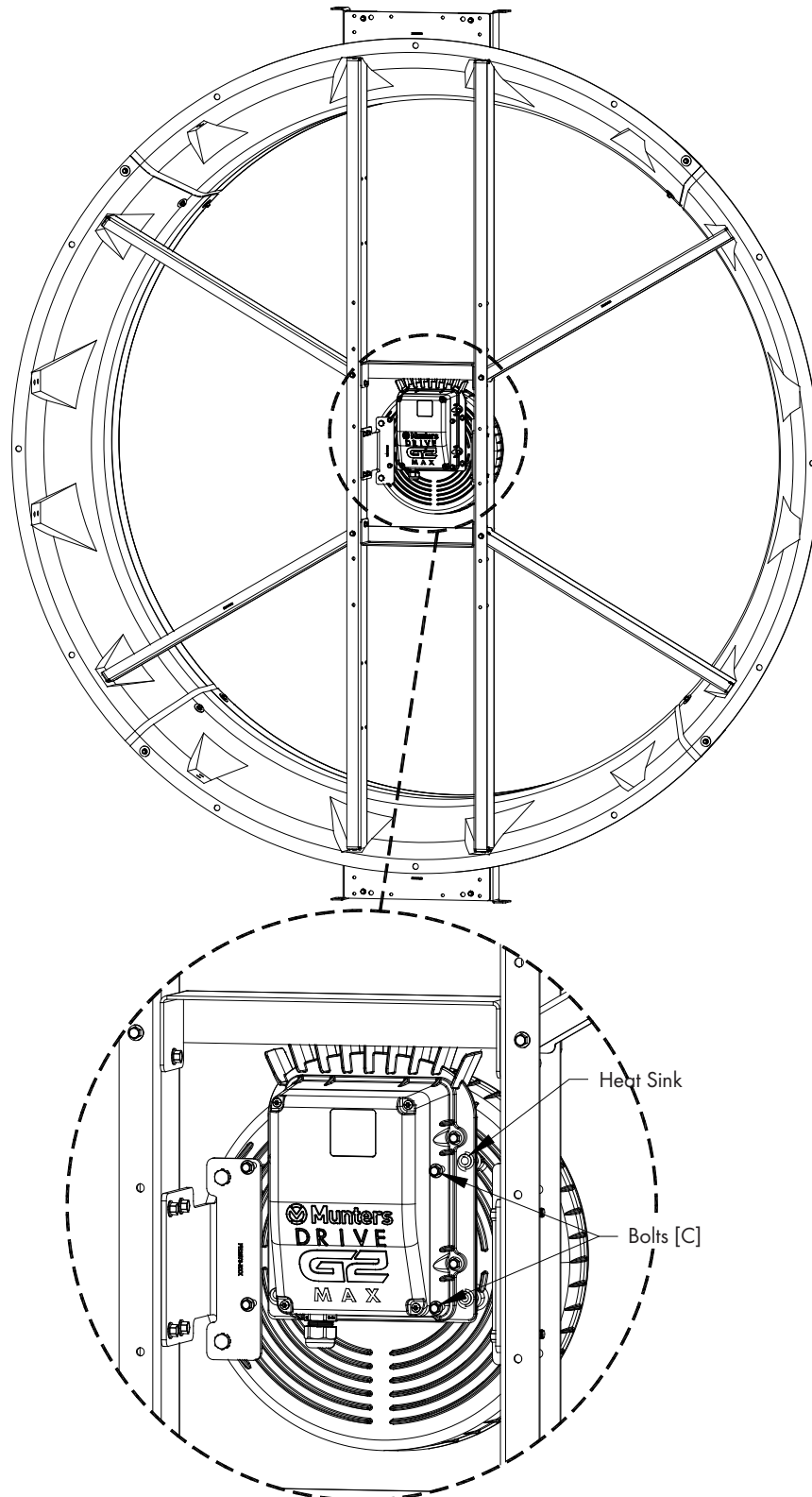
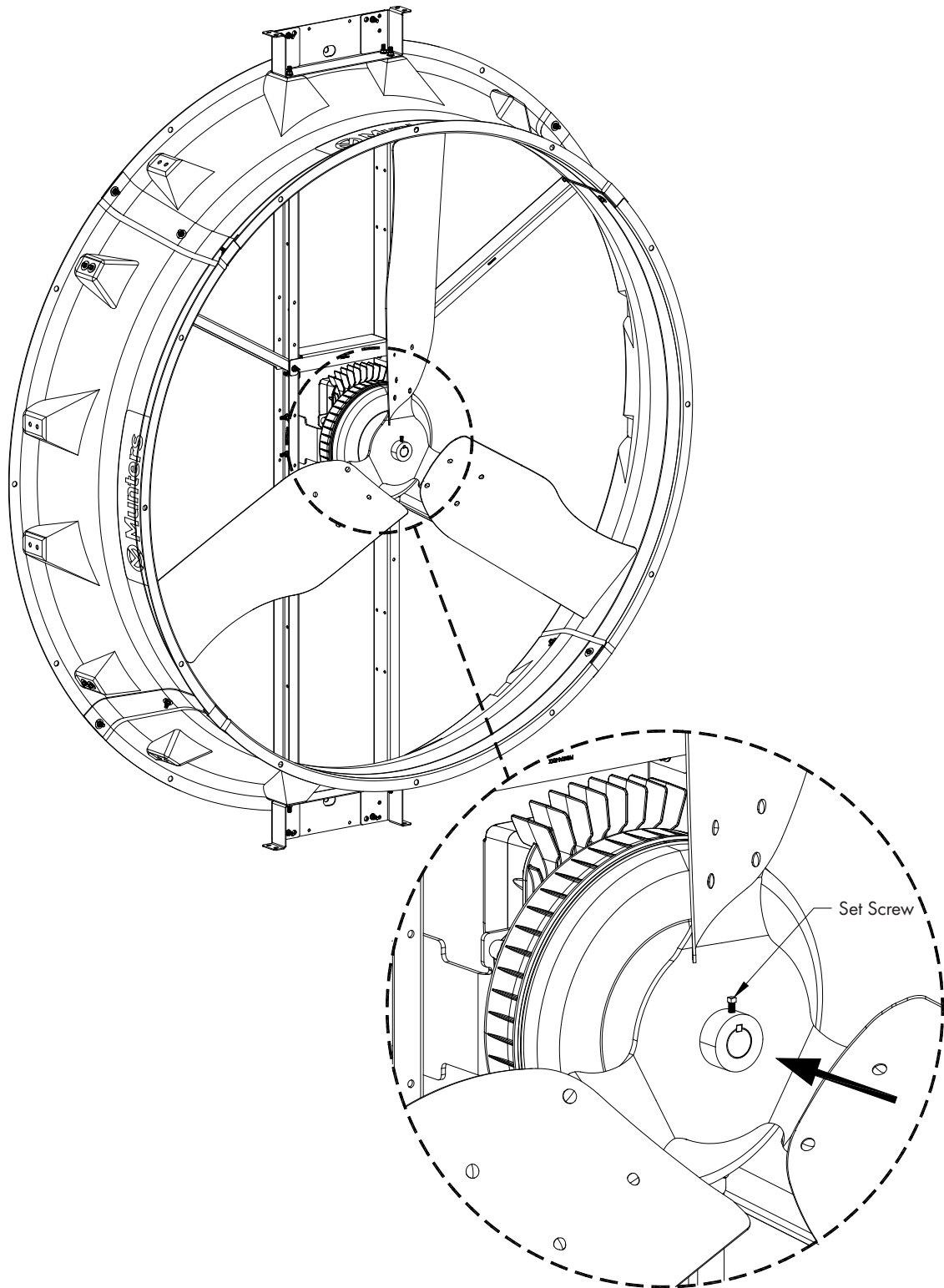

Figure 22



**Step 23**

Reinstall propeller onto the reinstalled Prop Adapter, replacing the key removed in Step 2. Tighten the Set Screw to 80 in-lbs. [9.0 Nm] of torque. See [Figure 23](#). If guards were removed previously, reinstall them at this time.



**Figure 23**

Munters Drive Rotor replacement kit is developed and produced by Munters Corporation, Lansing, Michigan U.S.A. 1-800-227-2376



Munters Europe AB, Isafjordsgatan 1, P.O. Box 1150, SE-164 26 Kista, Sweden. Phone +46 08 626 63 00, Fax +46 8 754 56 66.

Munters Corporation 2691 Ena Drive Lansing, MI 48917 U.S.A. Phone +1 800-227-2376, Fax +1 517-676-7078

[www.munters.us](http://www.munters.us)

[Australia](#) Munters Pty Limited, Phone +61 2 6025 6422, [Brazil](#) Munters Brasil Industria e Comercio Ltda, Phone +55 41 3317 5050, [Canada/US](#) Munters Corporation Lansing, MI Phone +1 517 676 7070, [China](#) Munters Air Treatment Equipment (Beijing) Co. Ltd, Phone +86 10 80 481 121, [Denmark](#) Munters A/S, Phone +45 9862 3311, [India](#) Munters India, Phone +91 20 3052 2520, [Indonesia](#) Munters, Phone +62 818 739 235, [Italy](#) Munters Italy S.p.A., Chiusavecchia, Phone +39 0183 52 11, [Japan](#) Munters K.K., Phone +81 3 5970 0021, [Korea](#) Munters Korea Co. Ltd., Phone +82 2 761 8701, [Mexico](#) Munters Mexico, Phone +52 818 262 54 00, [Russia](#) Munters AB, Phone +7 812 448 5740, [Singapore](#) Munters Pte Ltd., Phone +65 744 6828, [South Africa and Sub-Sahara Countries](#) Munters (Pty) Ltd., Phone +27 11 997 2000, [Spain](#) Munters Spain S.A., Phone +34 91 640 09 02, [Sweden](#) Munters AB, Phone +46 8 626 63 00, [Thailand](#) Munters Co. Ltd., Phone +66 2 642 2670, [Turkey](#) Munters Form Endüstri Sistemleri A.Ş., Phone +90 322 231 1338, [USA](#) Munters Corporation Lansing, MI Phone +1 517 676 7070, [Vietnam](#) Munters Vietnam, Phone +84 8 3825 6838, [Export & Other countries](#) Munters Italy S.p.A., Chiusavecchia Phone +39 0183 52 11