

Installation manual

Coanda Inlet



Coanda inlet

IS 600

IS 800

Munters reserves the right to make alterations to specifications, quantities, dimensions etc. for production or other reasons subsequent to publication.

The information contained herein has been prepared by qualified experts within Munters. While we believe the information is accurate and complete, we make no warranty or representation for any particular purpose. The information is offered in good faith and with the understanding that any use of the units or accessories in breach of the directions and warnings in this document is at the sole discretion and risk of the user.

Contents

IS 600 / 800 - INLET THROUGH THE LOFT

1. Assembly instruction	4
2. Assembly instruction: regulator arm on Star diffusor	6
3. Mounting the Inlet in the ridge	7
4. Mounting the Inlet in the ridge - through the loft	8
5. Mount the inlet on one side of the roof	9
6. Mount the inlet on one side of the roof - through the loft	10
7. Mount the flashing in the ridge	11
8. Mount the flashing on one side of the roof	12
9. Mount flexible flashing	13
10. Assembly instruction - Inlet with fan	14

IS 600 / 800 - INLET FROM LOFT

11. Assembly instruction - Air inlet from loft	15
12. Assembly instruction - Regulator arm on Star diffusor	16
13. Assembly instruction - Inlet from loft	17
14. Assembly instruction - Inlet Jupiter with fan	18

IS 600 / 800 - AIR DISTRIBUTOR - WIRE PULLING SYSTEM

15. Mount the air distributor under the inlet Saturn	19
16. Mounting the wire pulling system on diffusor placed in two rows	20
17. Mounting the wire pulling system on diffusor placed in one row	21
18. Mount the Nepronic on the diffusor	22

1 Assembly instruction - Inlet



Tools:

- 1 Drilling machine
- 1 Drill (5 mm)
- 1 Screwdriver (Philip)
- 1 Diagonal cutting nipper

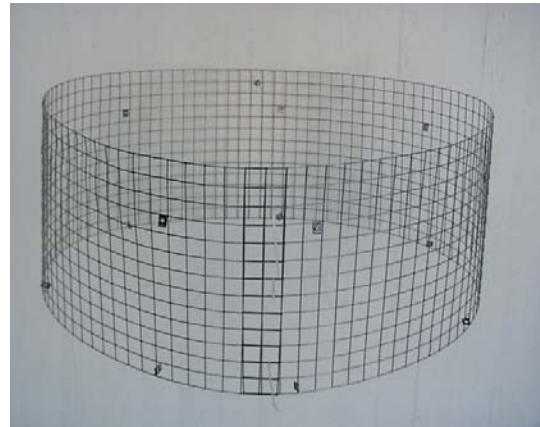

Fold the net into a circle and assemble with cable clips 2,5x98 (N131-063)



Place the bird net in the conic top.
Drill holes at each steel-clips.
Fasten with drilling screw 4,9x16
w/washer (H71-004)



Place the bird net onto the top.
Drill holes at each steel-clips.
Fasten with drilling screw 4,9x16
w/washer (H71-004)



Top complete

Assembly instruction - Inlet

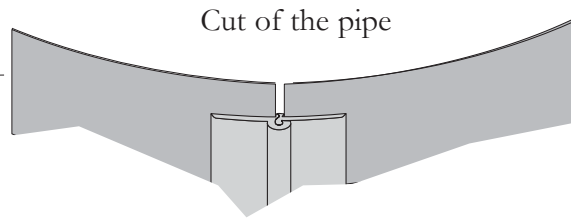
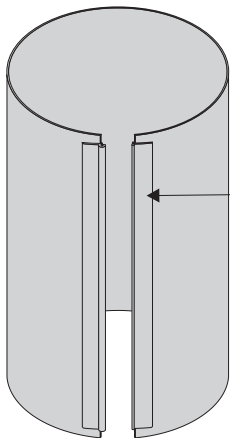

Click the two rolling junctions together

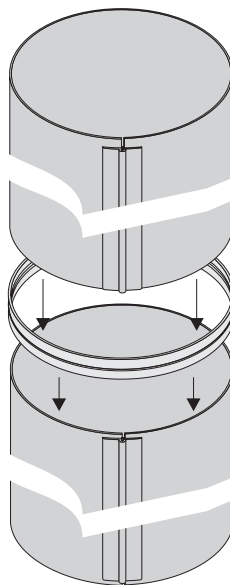

Push the sleeve down the pipe, and fasten it with 8 pcs. of sheet metal screws 4,8x16 (N136-121) and washers 5,3x15 stainless (02-420). Then push the next pipe into the sleeve and fasten with 8 pcs. of sheet metal screws 4,8x16 (N136-121) and washers 5,3x15 stainless (02-420).

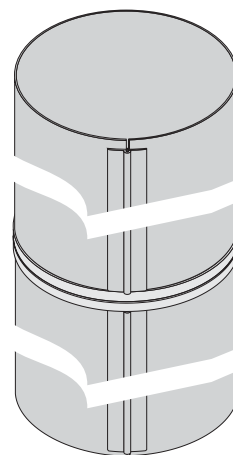

Assembled pipes

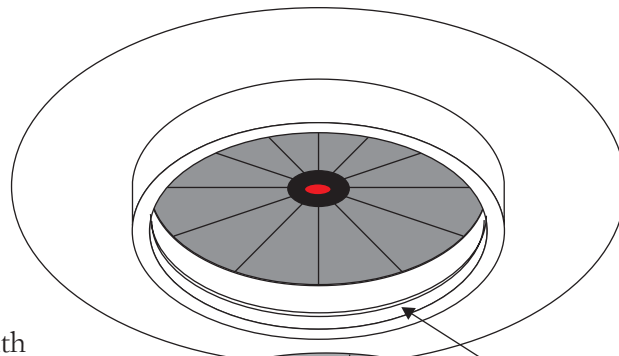

Screw 8 pcs. sheet metal screw 4,8x16 (N136-121) into the pipe and diffuser on level with the inlet suspension in the middle of the fold on the diffuser approx 12 cm from the edge of the diffuser.

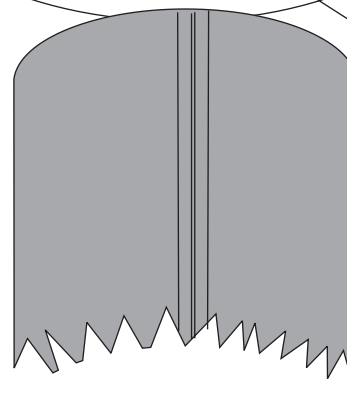
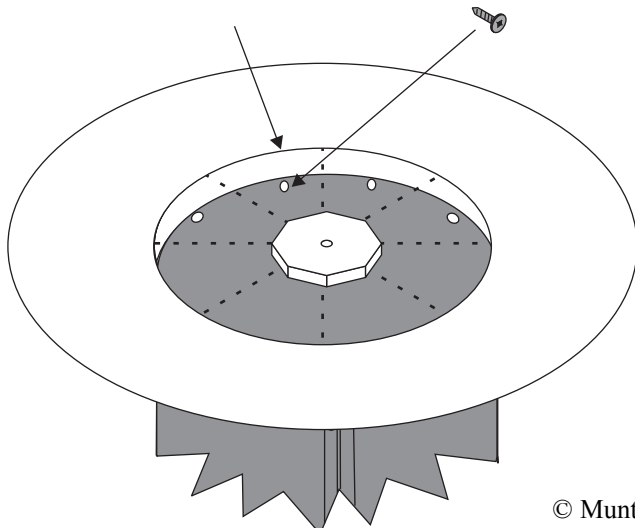

The pipe must be placed in the fold in the diffuser, so that the pipe is on level with the inside of the diffuser

2 Assembly instruction - Regulator arm on Star diffusor

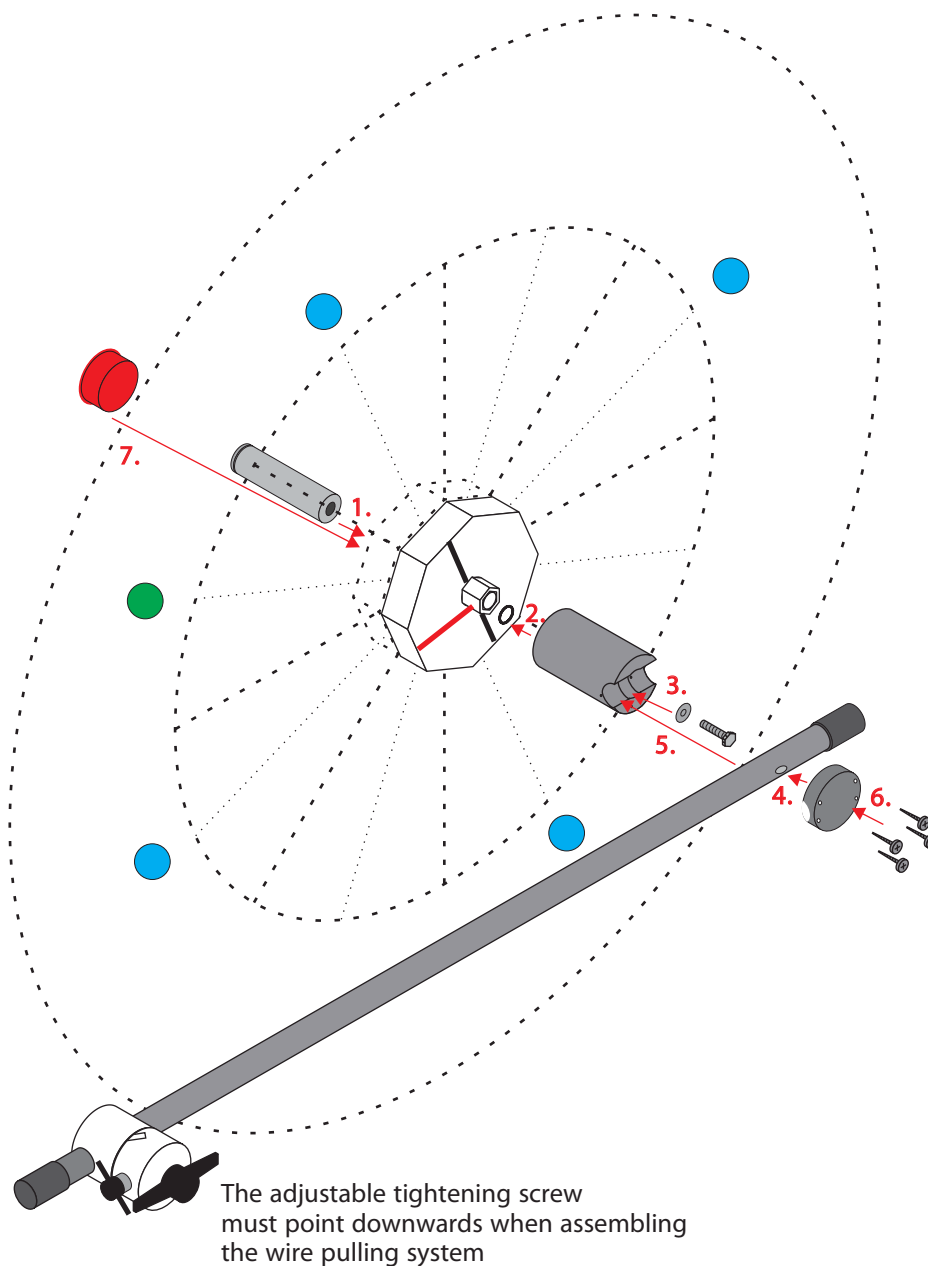

Place the Regulator arm in parallel with the red line on the hub (closed diffusor)

- The inlet suspension is placed on level with this point
- The cross-stiffening on the backside of the star diffusor is fastened on level with this point. This point must be placed so that a line can be drawn perpendicular to the side wall.

N.B.!! When the star diffusor is hung up, the Regulator arm must be placed to the left side, when you are standing faced to the wire pulling control center. (see page 12)

3 Mounting the inlet in the ridge

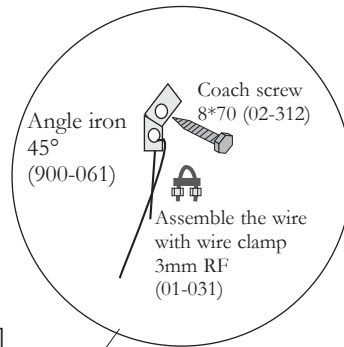
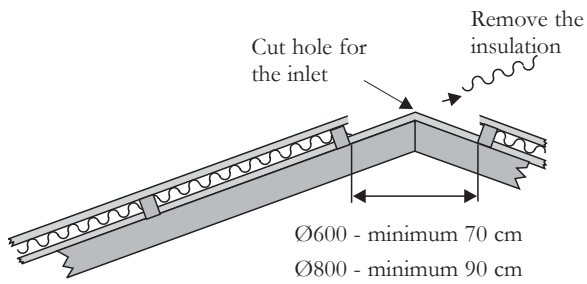

NB! If a fan in the inlet (see page 11)

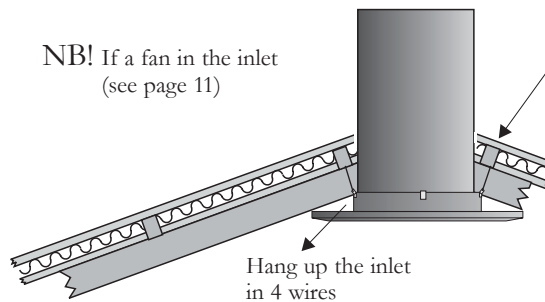

Mount as high up against the rafters as possible

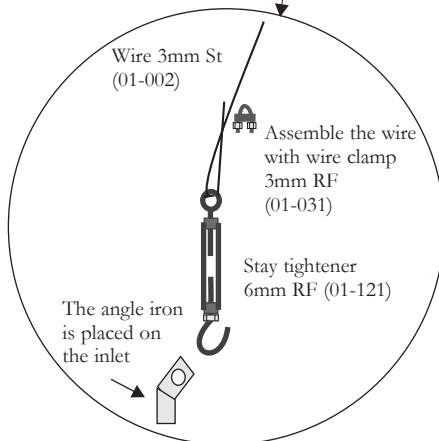

4 Mount the inlet in the ridge - through the loft

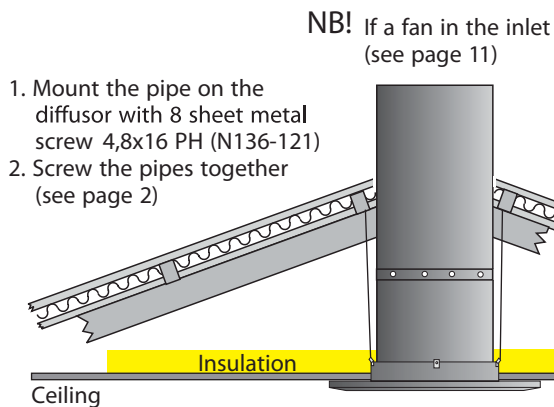
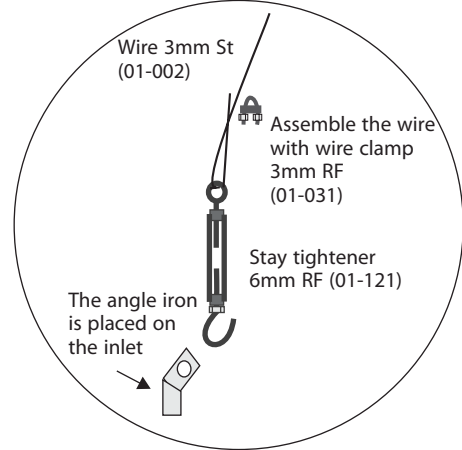
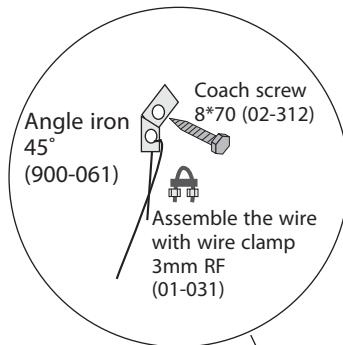
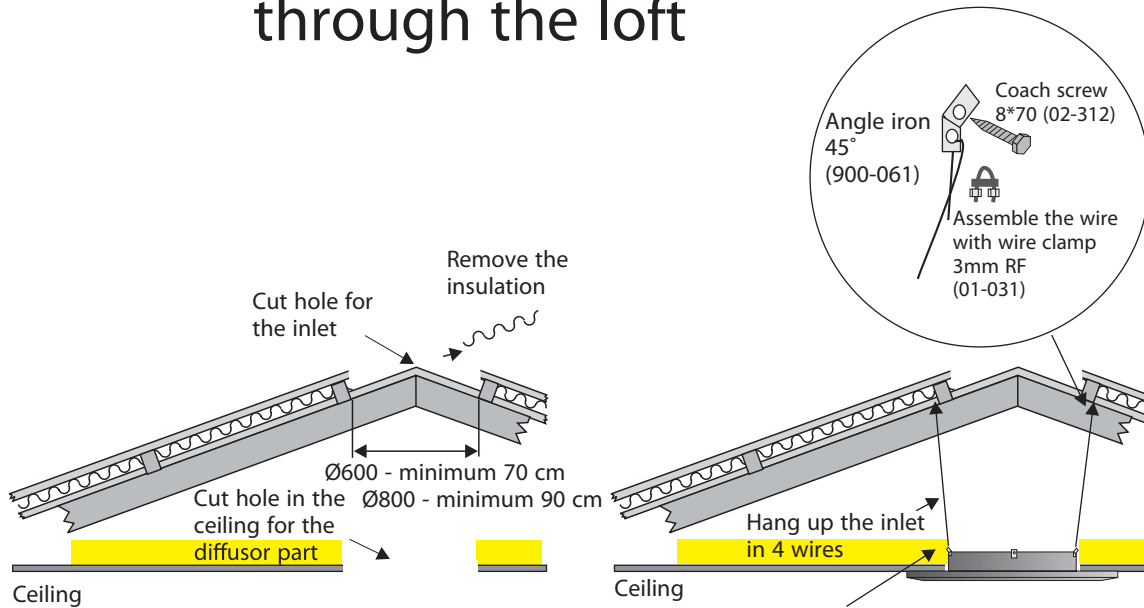

5 Mount the Inlet on one side of the roof

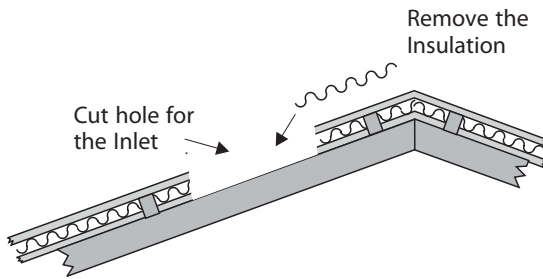

Hole size for Inlet

	TU 600	TU 800
25° Roof	687 mm	913 mm
20° Roof	662 mm	882 mm
15° Roof	645 mm	857 mm
	623 mm	828 mm

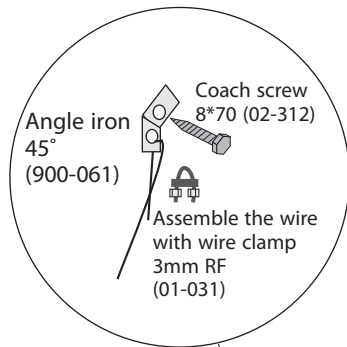

NB! If fan in the inlet (see page 11)

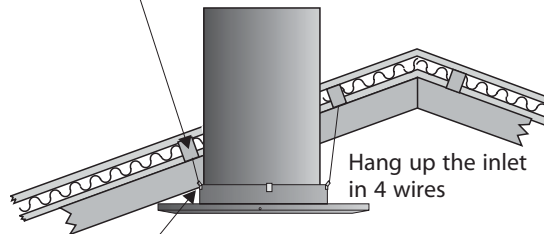

Mount as high up against the rafters as possible

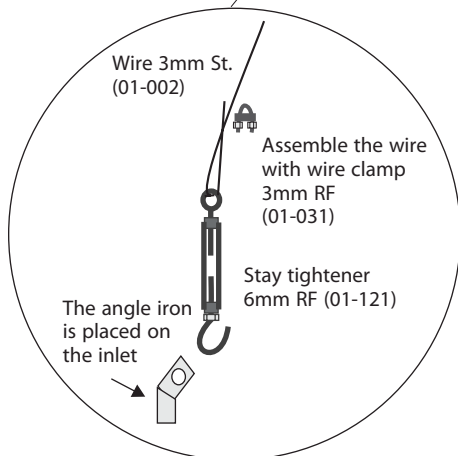

6 Mount the inlet on one side of the roof through the loft

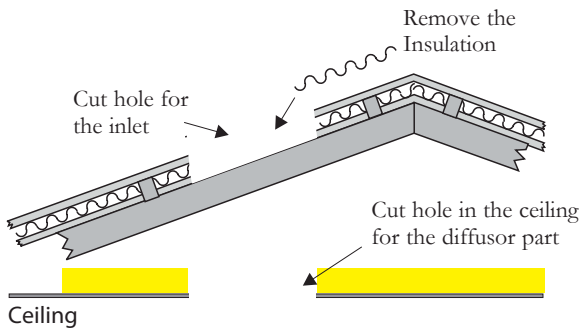

Hole size for Inlet

TU 600		TU 800	
25° Roof	687 mm	25° Roof	913 mm
20° Roof	662 mm	20° Roof	882 mm
15° Roof	645 mm	15° Roof	857 mm
623 mm		828 mm	

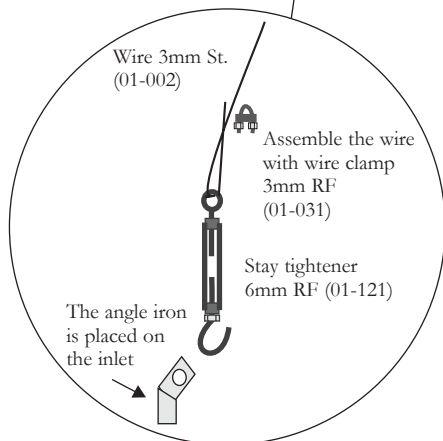
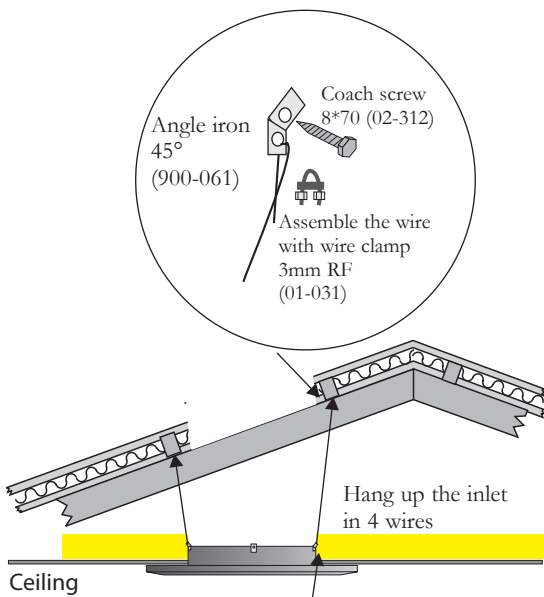

NB! If fan in the inlet (see page 11)

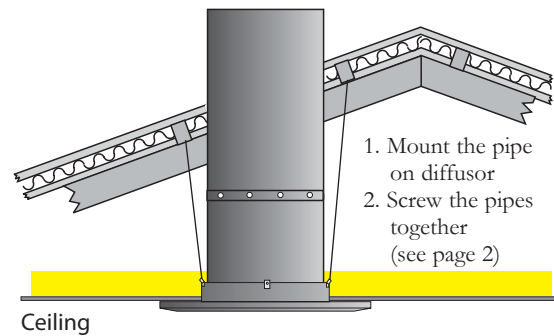

7 Mount the flashing in the ridge

Multiflex Ridge can be used for slopes of 10°, 15° and 20°



Multiflex ridge flashing placed on the pipe

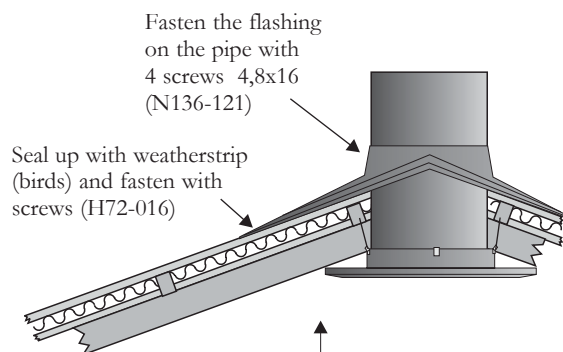

Push the rubber band over the pipe and flashing. Remove the white edging, and press the rubber band onto the pipe

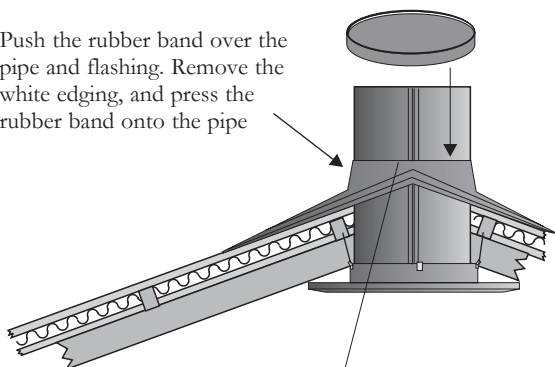

Important! Fasten the rubber band at 6 points both on the pipe and the flashing with screws, except the screws at the rolling junctions. Fasten with screws close to the edge of the rolling junctions

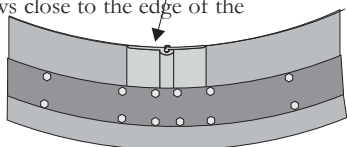

The same procedure

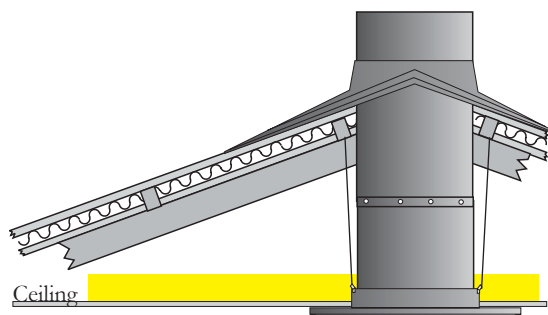

Push the top 60 mm down over the pipe and fasten with drilling screw 4,8x19 w/washer (H71-002)

Mounted Inlet

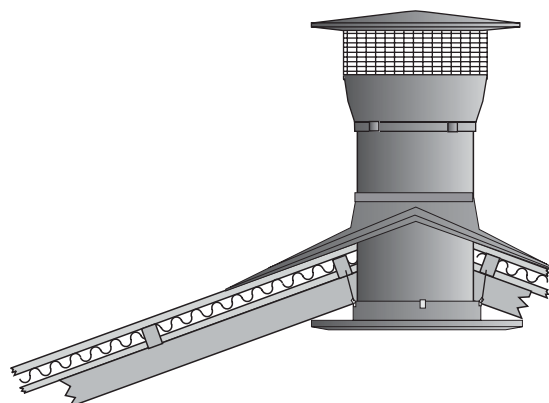

8 Mount the flashing on one side of the roof

Multiflex can be used for slopes of 10°, 15° and 20°

NB! If the roof is made of asbestos cement, put intermediate plate under the slit, and the procedure is the same as with steel plates

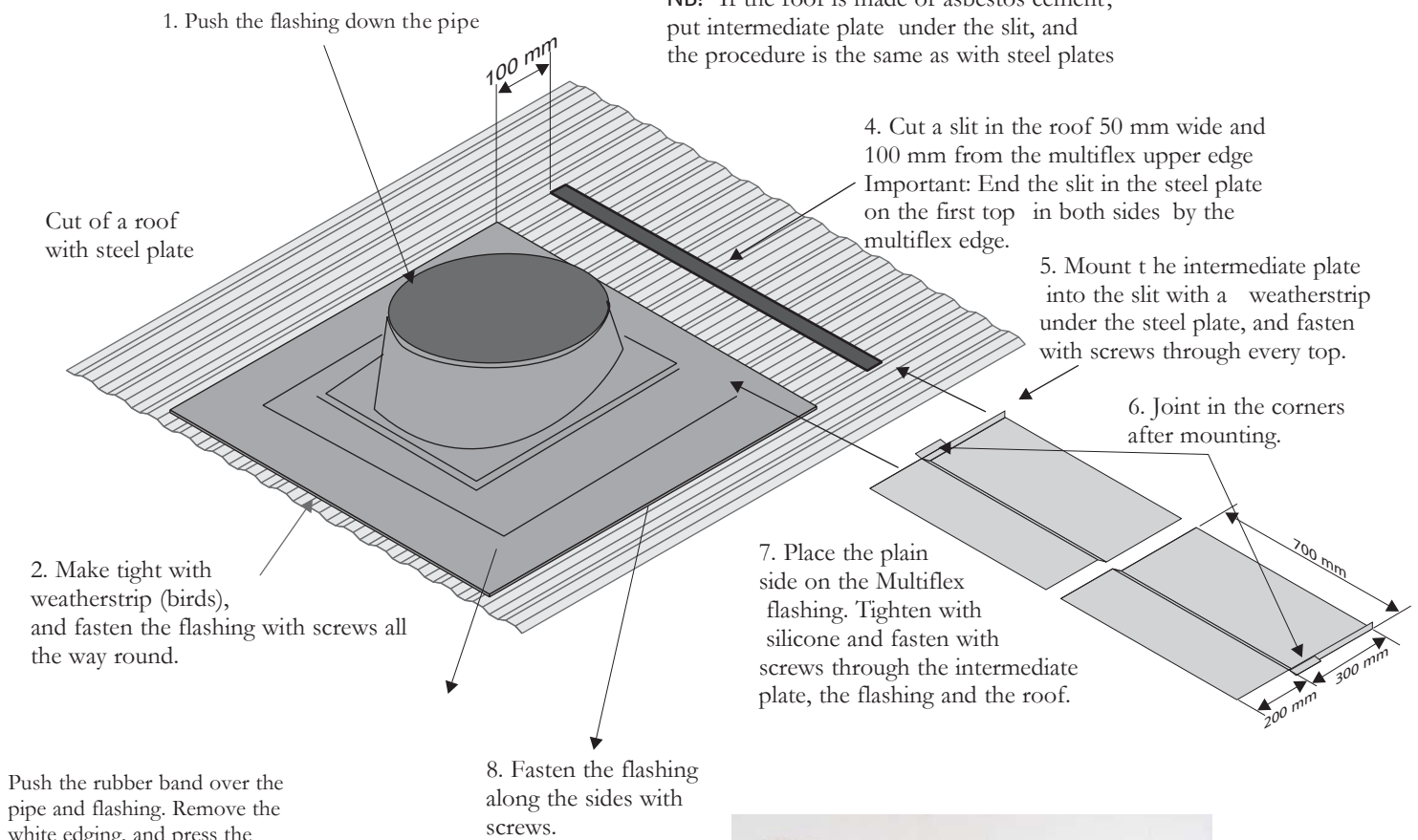

Push the rubber band over the pipe and flashing. Remove the white edging, and press the rubber band onto the pipe

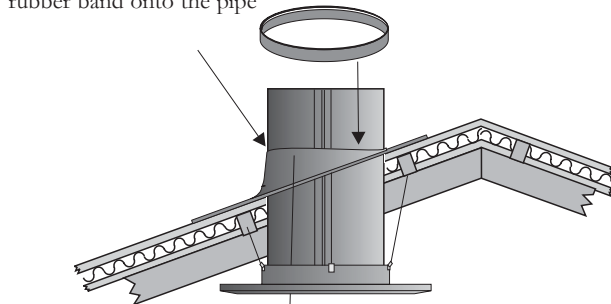

Important! Fasten the rubber band at 6 points both on the pipe and the flashing with screws, except the screws at the rolling junctions. Fasten with screws close to the edge of the rolling junctions

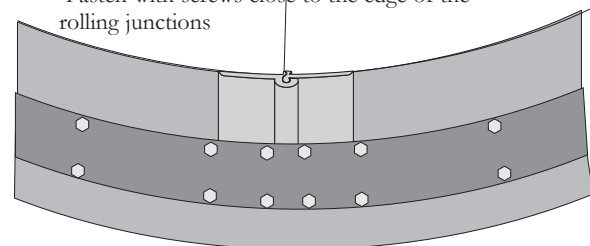

Push the top 60 mm down over the pipe and fasten with drilling screw w/washer 4,8x19 (H71-002)

Mounted flashing

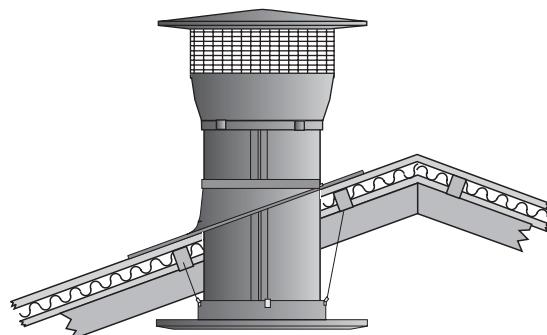

9 Mounting flexible flashing

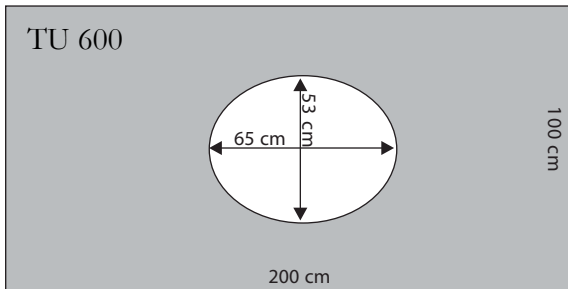

Cut a hole in the flashing according to the size in the drawing. The hole can be moved.

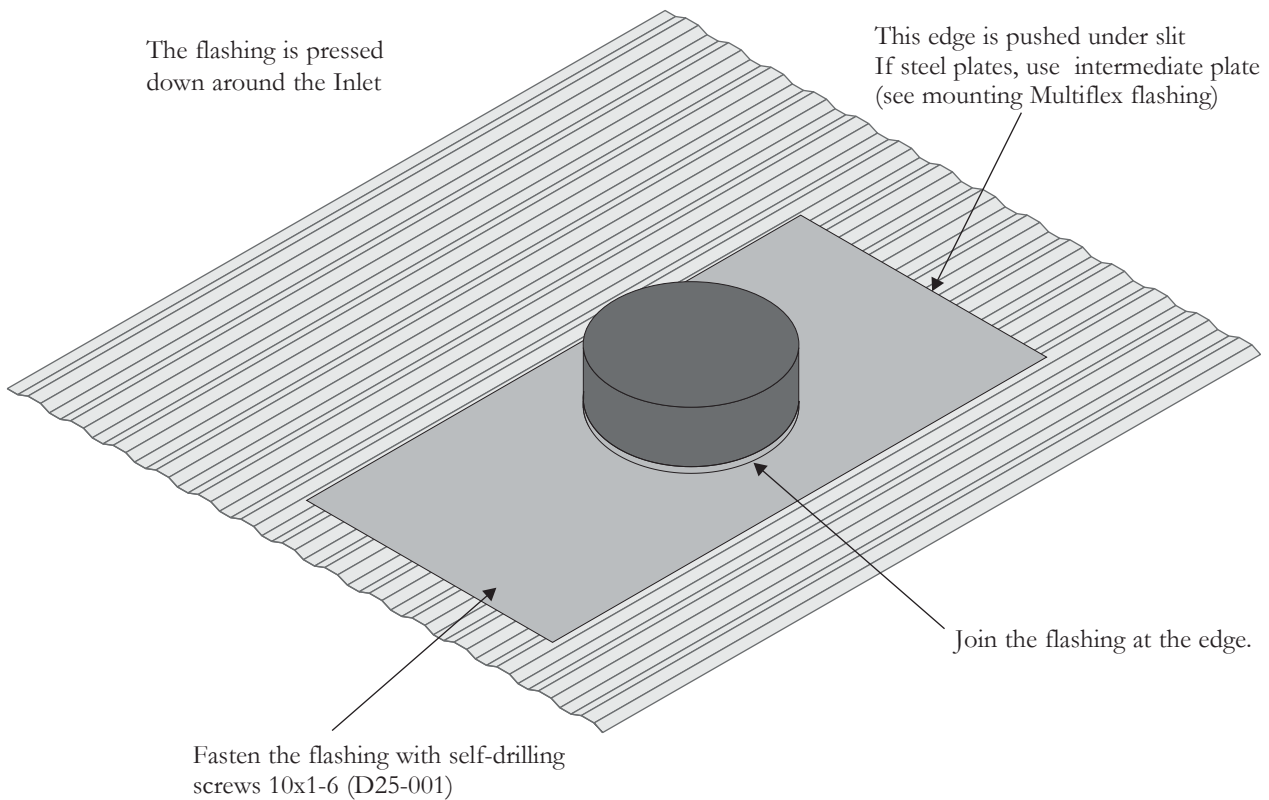
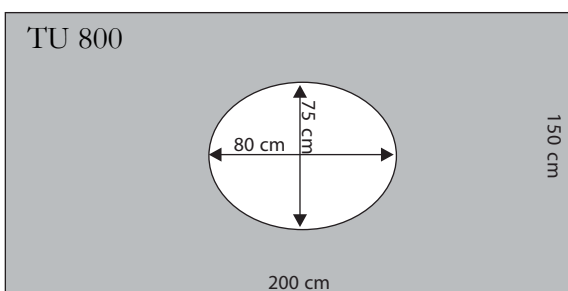

10 Assembly instruction - Inlet with fan



Fasten the fan on the shaft

Mount the flange on the motor with 4 set screw 6x16

Air inlet Ø600

NB! The fan blades are placed under the motor

Support-ring is mounted together with motor fittings and 45° angle iron

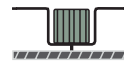
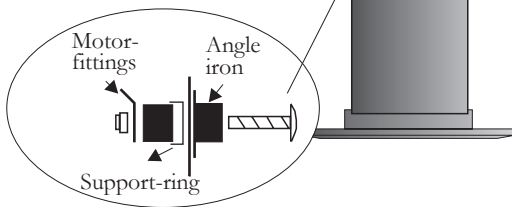

2. Mount the fan on motor suspensions which are mounted in the pipe

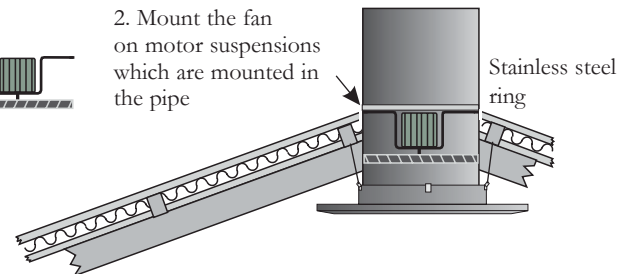

Air inlet Ø800

Mount 3- 4 pcs. motor fittings inside the pipe in rough-bored holes

Motor suspension

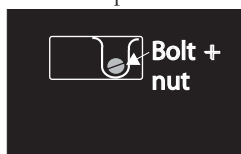

cut of the pipe

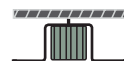

2. Mount the fan on motor suspensions which are mounted in the pipe in rough-bored holes

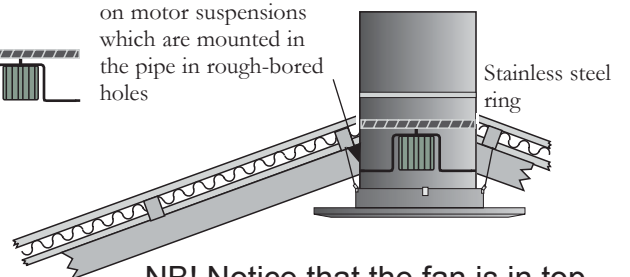

NB! Notice that the fan is in top at Ø800

11 Assembly instruction - Air inlet from loft

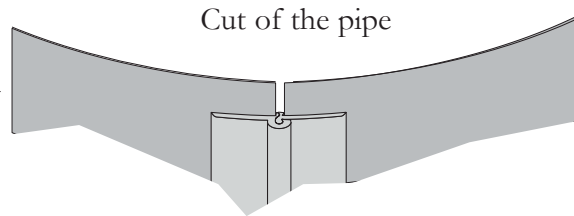
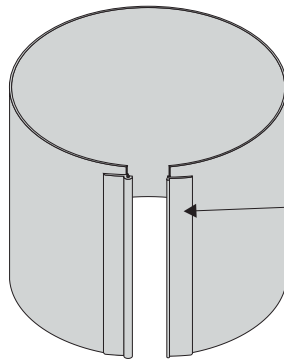

Click the two rolling junctions together

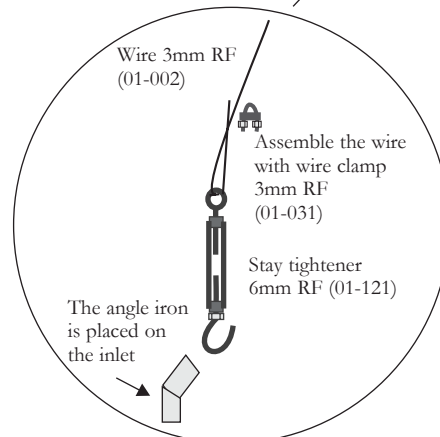
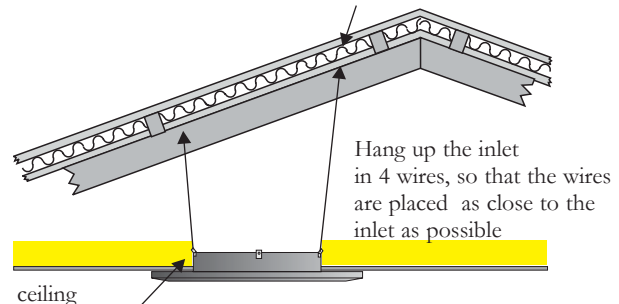
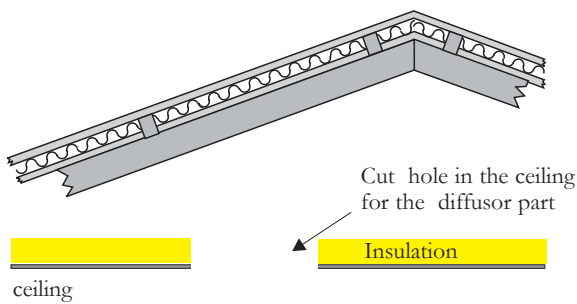
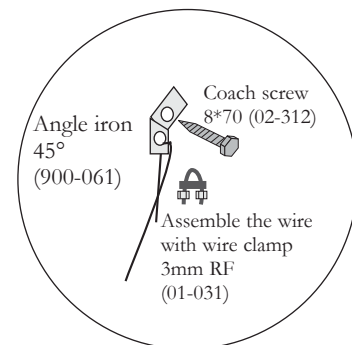
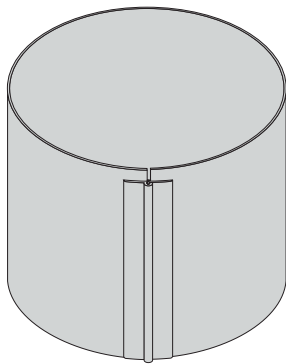

12 Assembly instruction - Regulator arm on Star diffusor

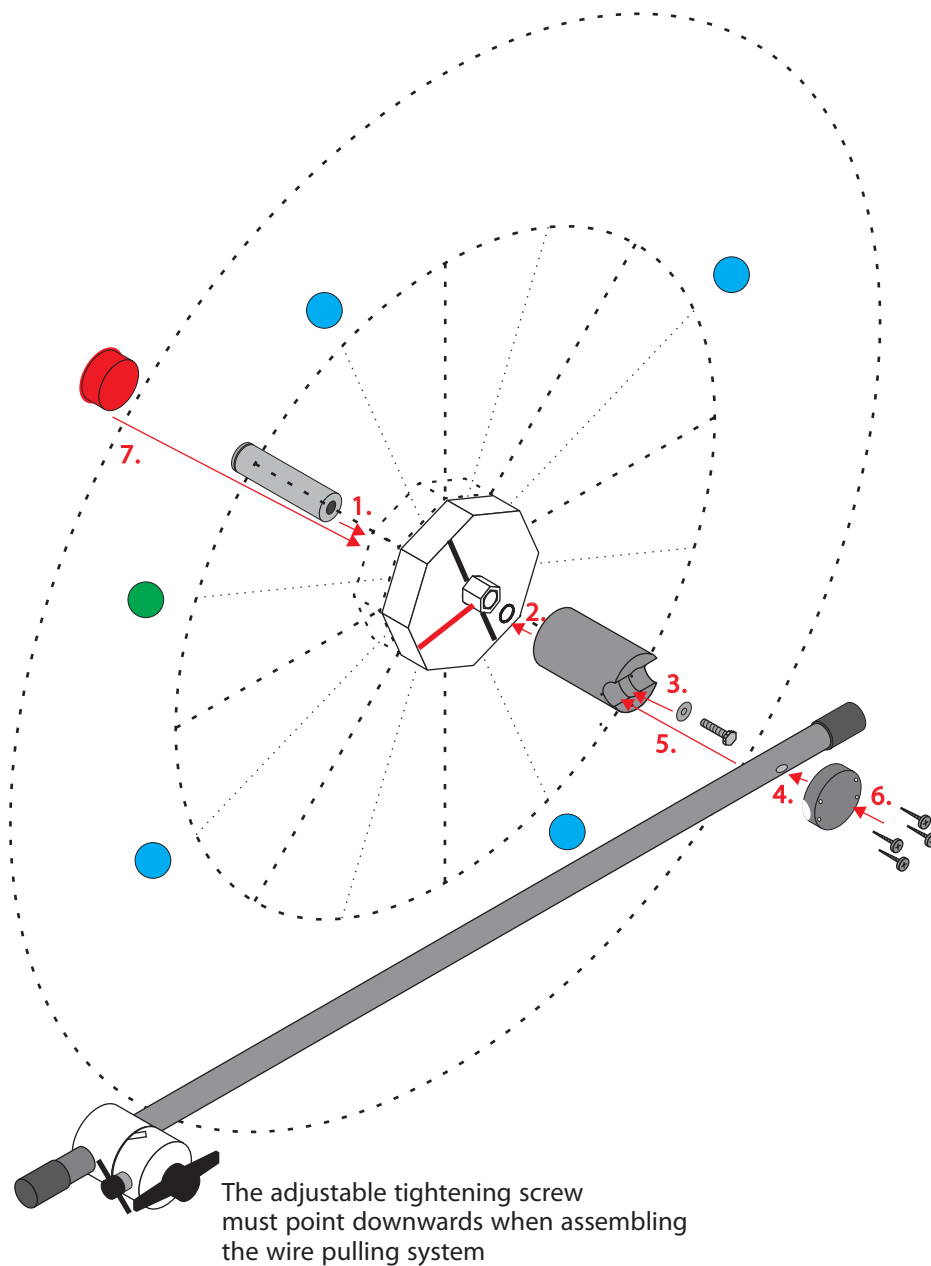

Place the Regulator arm in parallel with the red line on the hub (closed diffusor)

- The inlet suspension is placed on level with this point
- The cross-stiffening on the backside of the star diffusor is fastened on level with this point. This point must be placed so that a line can be drawn perpendicular to the side wall.

N.B.!! When the star diffusor is hung up, the Regulator arm must be placed to the left side, when you are standing faced to the wire pulling control center. (see page 12)

13 Assembly instruction - Inlet from loft

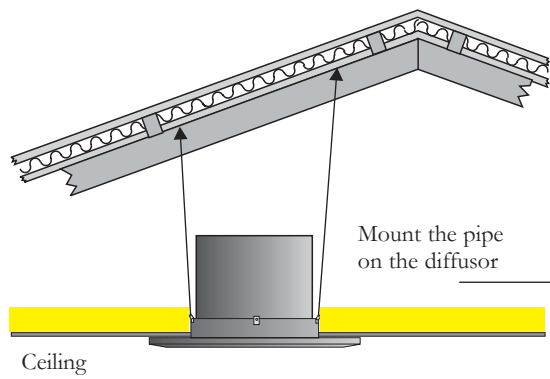

1. The pipe must be placed in the fold in the diffuser, so that the pipe is on level with the inside of the diffuser

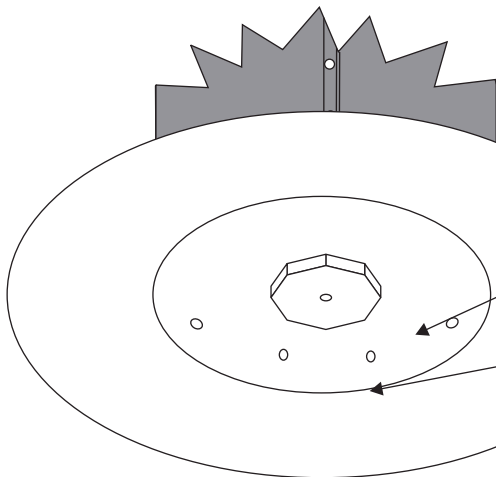
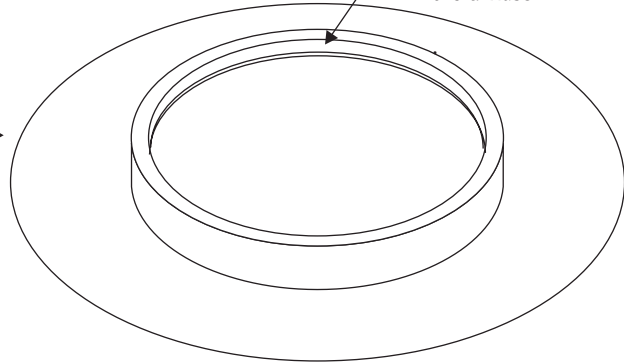

2. Screw 8 pcs. sheet metal screw 4,8x16 (N136-121) into the pipe and diffuser on level with the inlet suspension in the middle of the fold on the diffuser approx. 12 cm from the edge of the diffuser.

14 Assembly instruction - Inlet Jupiter with fan

Mount 3 pcs. motor fittings inside the pipe in rough-bored holes

Motor suspension

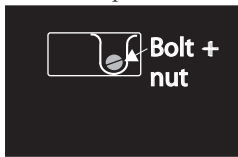

cut of the pipe

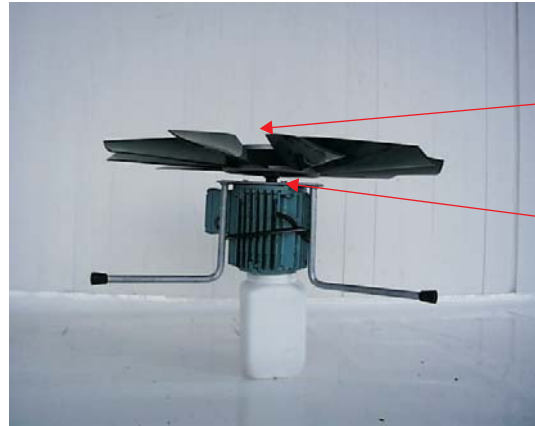

Fasten the fan on the shaft

Mount the flange on the motor with 4 set screw 6x16

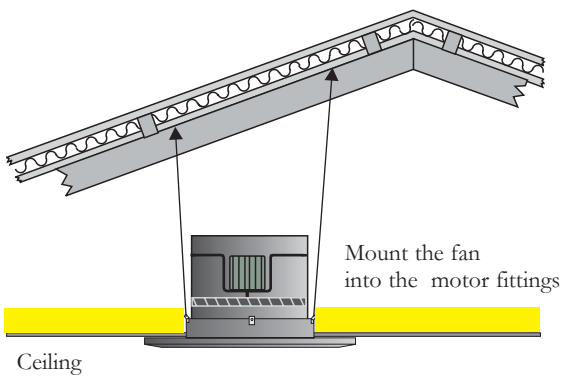

Mount the fan into the motor fittings

Ceiling

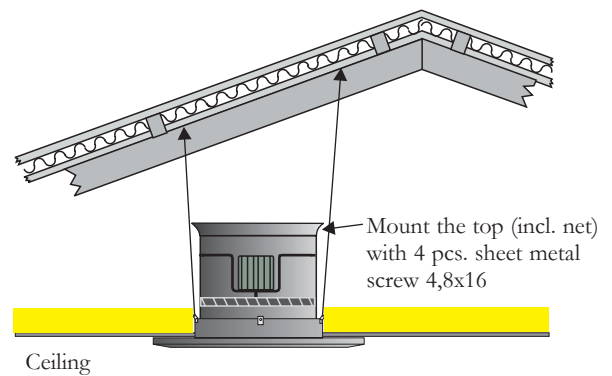

Mount the top (incl. net) with 4 pcs. sheet metal screw 4,8x16

Ceiling

NB !! The fan blades must be placed under the motor

15 Mount the air distributor under the inlet Saturn

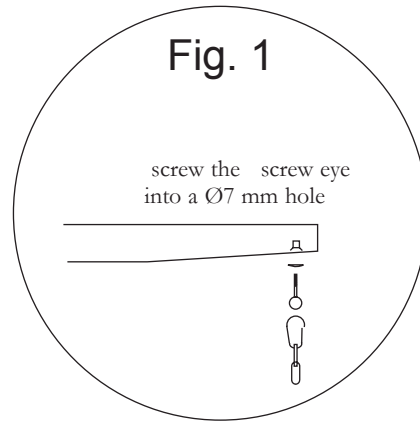
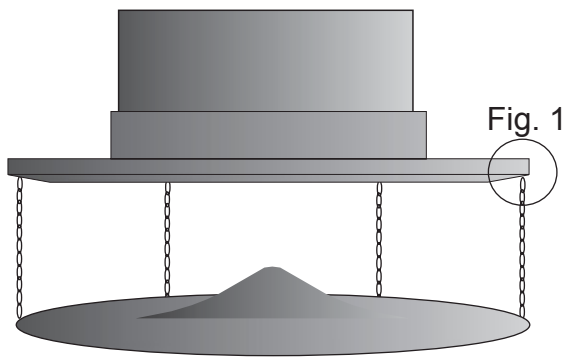

16 Mounting the wire pulling system on diffusers placed in 2 rows

Important!! When the diffuser is suspended, the Regulator arm must be on the left, when you face the damper controller (fig. 1 or 2)

NB!

The diffuser must be closed when mounting the wire. The Regulator arm will then be in a position of approx. 15° to the wire. Fasten the wire on the Regulator arm 55 cm from the center of the diffuser.

Fig. 4

Put the wire through a snap hook and fasten with 2 clamps. Hang the weight in the snap hook

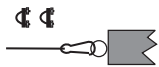
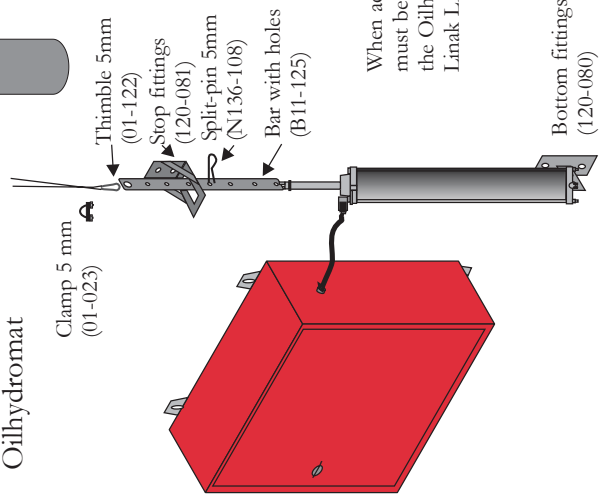
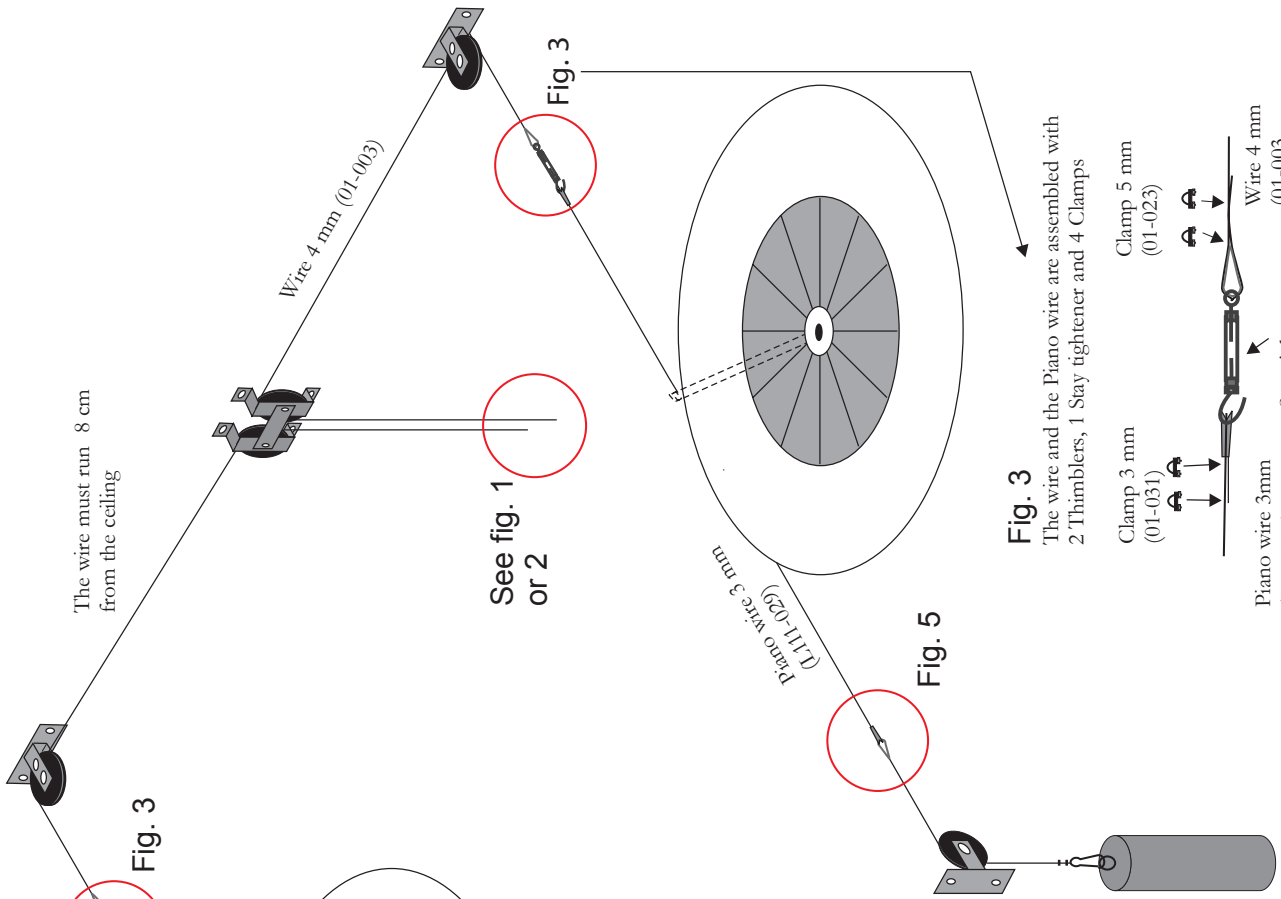
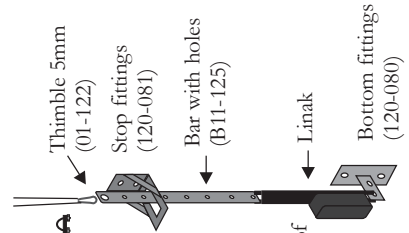

Fig. 1
Oilhydromat



When adjusting, the actuator rod must be down (closed). The stroke of the Oilhydromat and Linak LA32 are 32 cm.

Fig. 2
Linak LA32



See fig. 1 or 2

Fig. 3

The wire and the Piano wire are assembled with 2 Thimblers, 1 Stay tightener and 4 Clamps

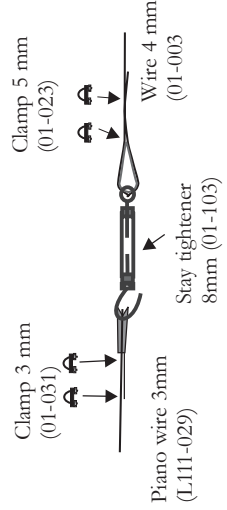

Fig. 5

17 Mounting the wire pulling system on diffusers placed in 1 row

Important!! When the diffuser is suspended, the Regulator arm must be on the left, when you face the damper controller (fig. 1 or 2)

NBI!

The diffuser must be closed when mounting the wire. The Regulator arm will then be in a position of approx. 15° to the wire. Fasten the wire on the Regulator arm 55 cm from the center of the diffuser.

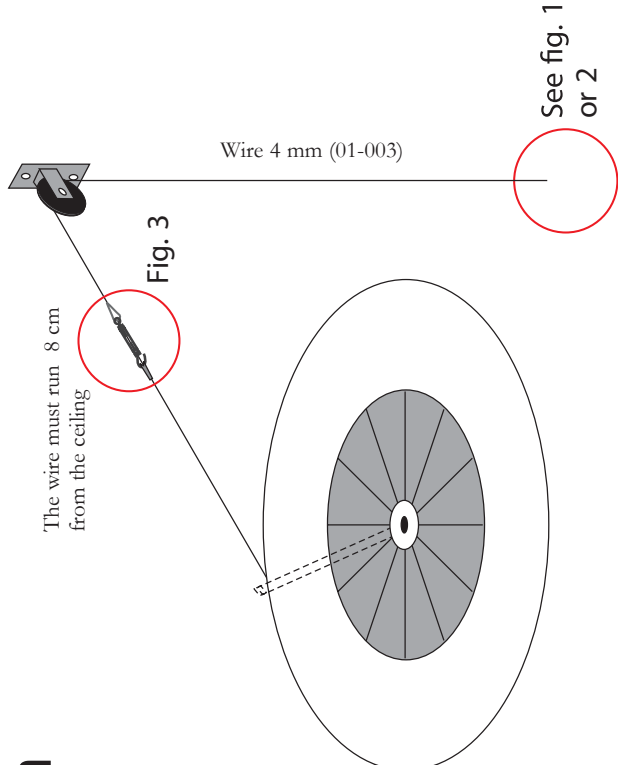

Fig. 5

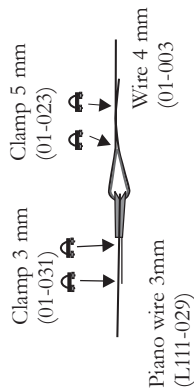

Fig. 4

Put the wire through a snap hook and fasten with 2 clamps. Hang the weight in the snap hook

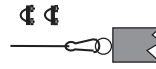

Fig. 5



Fig. 4

The wire and the Piano wire are assembled with 2 Thimbles, 1 Stay tightener and 4 Clamps

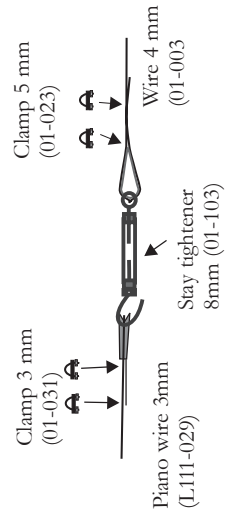
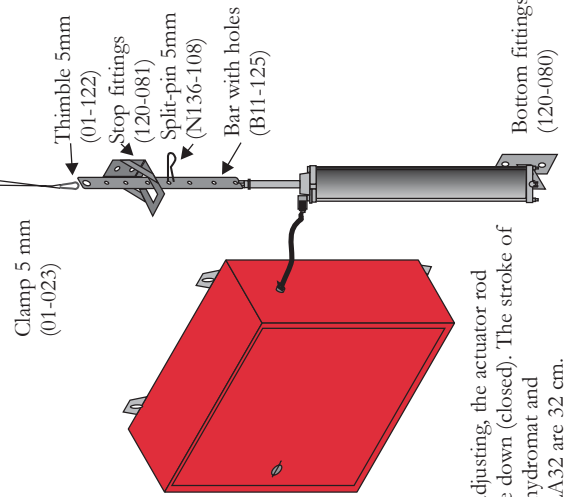

Fig. 3

Fig. 1 Oilhydromat



When adjusting the actuator rod must be down (closed). The stroke of the Oilhydromat and Linak LA32 are 32 cm.

Fig.2 Linak LA32

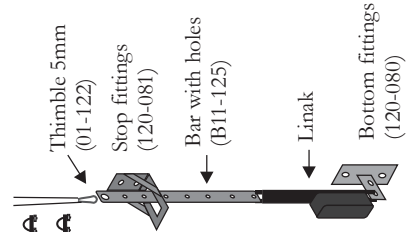

18 Mount the Neptronic on the diffusor

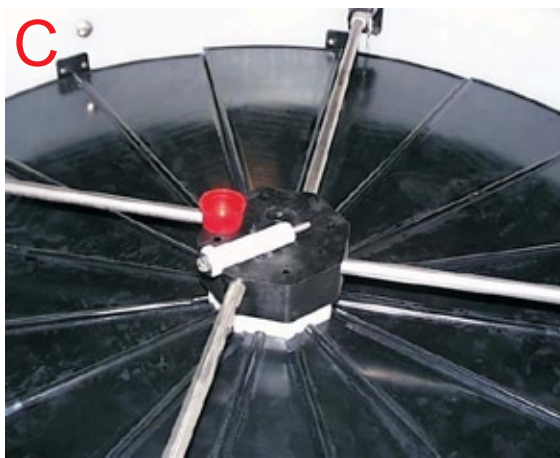

IS Coanda fan is developed and produced by Munters Turbovent A/S, Denmark



Munters Europe AB, HumiCool Division, Isafjordsgatan 1, P O Box 1150, SE-164 26 KISTA, Sweden.
Phone +46 08 626 63 00, Fax +46 8 754 56 66. www.munters.com

Australia Munters Pty Limited, Phone +61 2 6025 6422, **Brazil** Munters Brasil Industria e Comercio Ltda, Phone +55 11 5054 0150, **Canada** Munters Incorporated, Phone + 1 905 858 5894, **China** Munters Air Treatment Equipment (Beijing) Co., Ltd., Phone +86 10 80 481 121, **Denmark** Munters Turbovent, Phone +45 98623311, **Finland** Munters Oy, Phone +358 9 83 86 030, **France** Munters France S.A., Phone +33 1 34 11 57 50, **Germany** Munters Euroform GmbH, Phone +49 241 89 0 00, **India** Munters India, Phone +91 20 30522520, **Indonesia** Munters Phone +62 21 9105446-7, **Italy** Munters Italy S.p.A., **Chiusavecchia** Phone +39 0183-52 11, Munters Italy S.p.A., **Mondovi** Phone +39 0174 560 600 **Japan** Munters K.K., Phone +81 3 5970 0021, **Kingdom of Saudi Arabia and Middle East** Hawa Munters, Phone +966 1 477 15 14, **Korea** Munters Korea Co., Ltd, Phone +82 2 761 8701, **Mexico** Munters Mexico Phone +52 722 270 40 30, **Russia** Munters Europe AB, Phone +7 812 4485740, **Singapore** Munters Pte Ltd +65 744 6828 **South Africa and Sub-Sahara Countries** Munters (Pty) Ltd, Phone +27 11 971 9700, **Spain** Munters Spain S.A., Phone +34 91-640 09 02, **Sweden** Munters Europe AB, Phone +46 8 626 63 00, **Thailand** Munters (Thailand) Co. Ltd., Phone +66 2 645 2708-12, **United Kingdom** Munters Ltd, Phone +44 845 644 3980, **USA** Munters Corporation **Fort Myers**, Phone +1 239 936 1555, Munters Corporation **Mason**, Phone +1 888 335 0100, **Vietnam** Munters Vietnam Phone +84 8 825 6838 **Export & Other countries** Munters Europe AB, Phone +46 8 626 63 00

Munters reserves the right to make alterations to specifications, quantities, etc., for production or other reasons, subsequent to publication.
© Munters AB, 2008