



ATLAS 74

Belt Drive and Munters Drive G2 MAX

Sustainable performance, for a comfortable, healthy herd.

Features

- Top combined CFM and CFM/Watt performance: 53,000 cfm and 21.0 CFM/Watt @ .10 SP- the perfect combination of airflow and energy savings.
- Now available with Munters Drive. Experience the power of the longest-running EC motor technology for agriculture, with over 35,000 drives sold worldwide.
- North American made belt drive motor offers exceptional performance and up to 88% efficiency.
- Integrated control box: Enjoy hassle-free setup with plug-and-play programming, saving you hours of valuable set up time.
- Munters Drive G2 handles high static pressure better than other fans in its class, with the ability to operate efficiently up to .30 SP.
- Durable fiberglass housing: Rely on the robustness of fiberglass housing for long-lasting performance.
- PVC shutters and pre-assembled extreme weather support kit: Save time and effort during installation and maintenance with our convenient pre-assembled kit.
- Qualifies for energy rebates: Take advantage of regional energy rebates helping you save on costs while investing in efficiency.
- Munters Lift Bracket reduces installation labor by 25 minutes per fan and minimize the risk of damage during installation, for a smoother and more efficient process.

Longevity and value matter when choosing a ventilation system. Munters is the global leader in agricultural ventilation systems bringing a depth of expertise to our processes. But our commitment remains to US made products.

The Atlas 74 and Munters Drive are designed, engineered and built in the USA with premium American-made parts for the demanding conditions of a modern dairy operation. Featuring a corrosion-resistant fiberglass housing that is easy to clean and built to withstand tough conditions.

Atlas is available with a belt drive or with Munters Drive G2 MAX:

- Lowers electrical usage—saving up to 40% annually
- Qualifies for rebates from local utility companies
- Decreases the need for complex wiring systems
- Virtually maintenance-free

Atlas is designed to provide the best airflow for fewer fans to install and maintain. Ask for our Total Cost of Ownership calculation tool and you will see for yourself that Munters is the best value when it comes to your dairy operation.

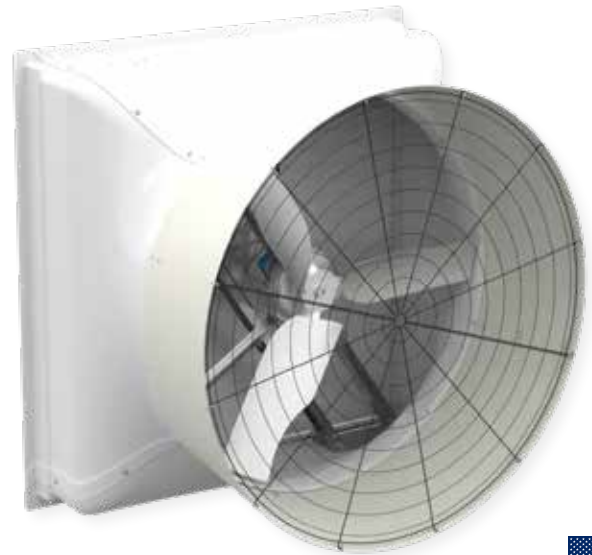

Munters Drive G2 MAX



Integrated lift bracket

ATLAS 74

Sustainable performance, for a comfortable, healthy herd.

Technical specifications

Dimensions

Fan Diameter	74"
A	5½"
B	21½"
C	44½"
D	89"
E	89"
F	13⅞"
G	35¾"
H	60⅜"
J	2⅝"
K - Diameter	85⅜"
Wall Opening	85"Wx85"H

Measurement diagram for reference only.

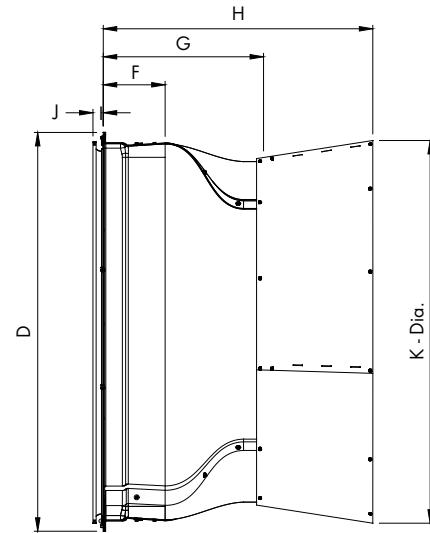

Belt Drive Performance[◊]

Static Pressure	Premium Belt		Efficient Belt	
	CFM	CFM/WATT	CFM	CFM/WATT
0.00"	57,700	27.5	54,900	29.3
0.05"	54,100	24.1	51,200	25.6
0.10"	50,400	21.2	47,400	22.4
0.15"	46,500	18.7	43,100	19.4
0.20"	42,100	16.2	38,200	16.5
0.25"	36,700	13.6	33,000	13.7
0.30"	28,700	10.5	22,400	9.3
Airflow Ratio	0.78		0.75	

[◊]Tested in accordance with AMCA Standard 210

Munters Drive G2 MAX Performance[◊]

Static Pressure	High Output (HO)		High Efficiency (HE)	
	CFM	CFM/WATT	CFM	CFM/WATT
0.00"	59,800	27.0	56,700	29.1
0.05"	56,400	23.7	53,000	25.3
0.10"	53,000	21.0	49,100	21.9
0.15"	49,000	18.5	44,500	18.8
0.20"	44,800	16.2	39,800	16.0
0.25"	39,900	13.7	33,200	12.7
0.30"	31,700	10.75	21,900	8.3
Airflow Ratio	0.79		0.75	

[◊]Tested in accordance with AMCA Standard 210

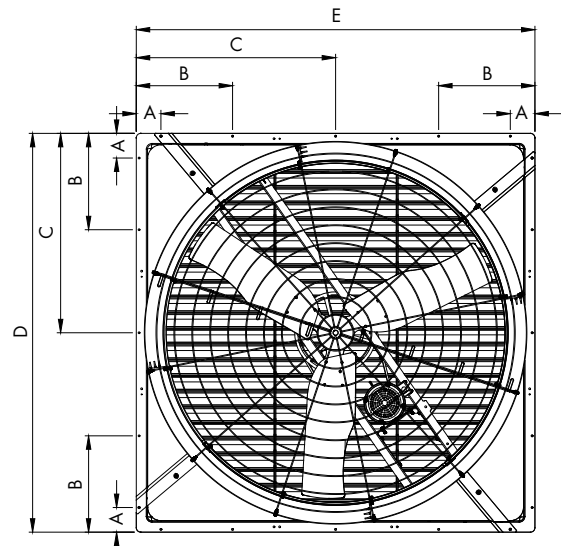

Find your nearest Munters office at www.munters.com

Munters reserves the right to make alterations to specifications, quantities, etc., for production or other reasons, subsequent to publication. © Munters Corporation, 2023