

Munters Plate PVX

Indirect air-side economizer with dry heat exchanger technology

Features

- Up to 80,000 CFM airflow
- Up to 500kW cooling capacity per unit
- 3 modes of operation:
 - Economizer
 - Economizer + DX
 - Full DX
- Munters aluminum plate heat exchanger technology
- Annualized pPUE typically less than 1.15
- Rooftop or perimeter mount
- Close side-by-side install option

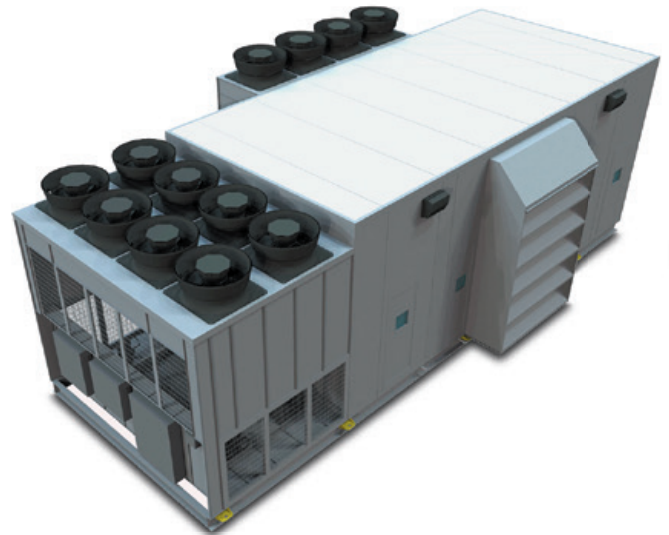

Munters Plate PVX indirect air-side economizer provides energy efficient data center heat rejection and low total cost of ownership.

Plate PVX units use an aluminum air-to-air heat exchanger to indirectly cool warm data center air towards ambient air, while keeping the ambient air separated from the recirculating room air. These heat exchangers provide 100% indirect economizer cooling during cooler ambient conditions. As ambient conditions become warmer, the Plate PVX system stages refrigeration on as required to maintain the target supply temperature. Economizer cooling remains as long as the ambient temperature is cooler than the warm air from the data center. The PVX aluminum plate heat exchanger contains no moving parts and essentially zero air leakage affording owners with reliable, low maintenance operation with no intrusion of ambient humidity or pollution into the data center.

Munters is a trusted leader in data center cooling technologies, and we make it our goal to provide reliable and efficient solutions that maximize energy savings for our customers.

Rooftop mount

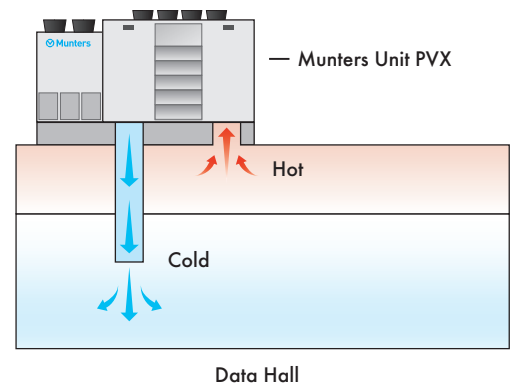

Perimeter mount

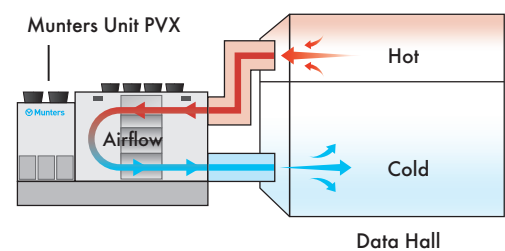

Munters Plate PVX

Indirect air-side economizer with dry heat exchanger technology

Options

- DX or chilled water supplemental cooling
- Right hand and left hand access models
- Modbus or BACnet® compatible controls
- Isolation dampers
- EC motor driven process, scavenger, and condenser fans
- Corrosion resistant coating on condenser coils
- Automatic transfer switch
- Controls power UPS

Mode 1 - Economizer

During cooler ambient conditions, the PVX system operates exclusively as an indirect air side economizer with no refrigeration.

Mode 2 - Economizer + DX

As ambient conditions become warmer, the PVX system stages refrigeration on to supplement the indirect air side economizer.

Mode 3 - Full DX

As ambient conditions no longer support any economizer cooling, the PVX system operates exclusively with refrigeration cooling.

Sample Perimeter Mount Installation

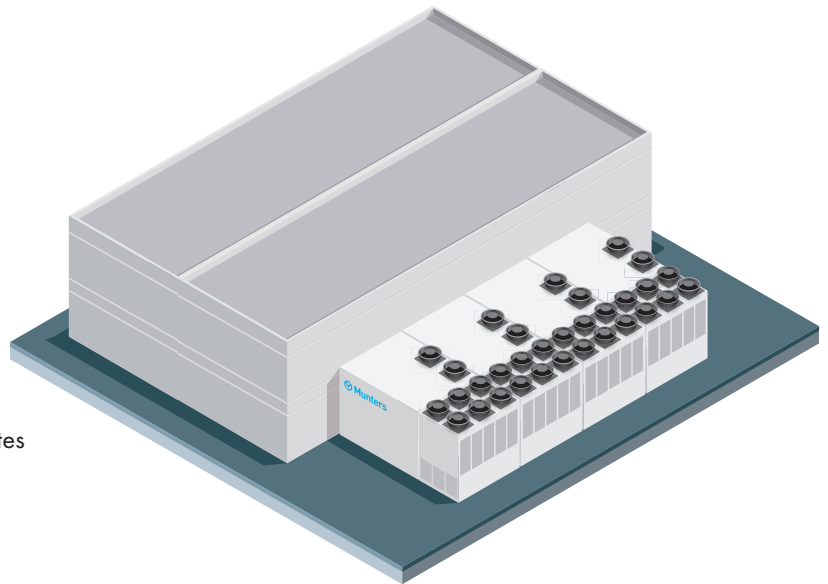

Sample Rooftop PVX Air Handler*

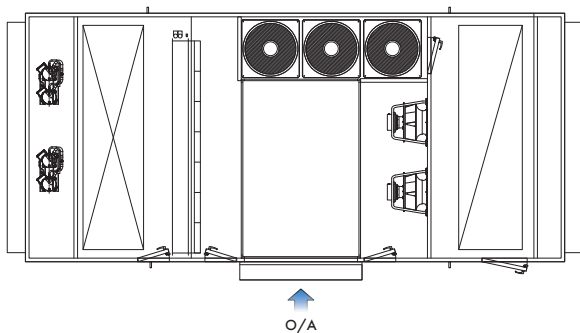

Plan View - Roof Removed

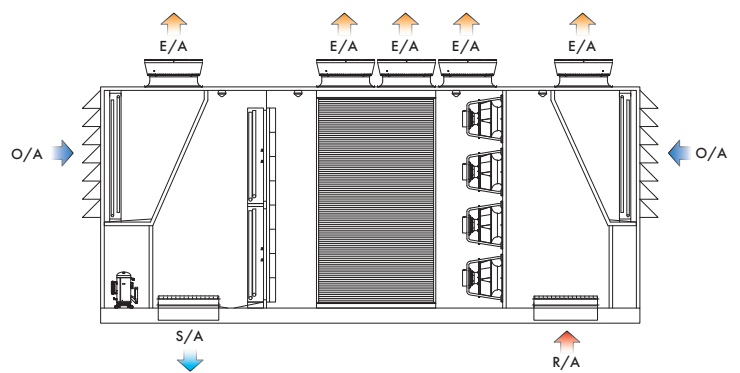

Elevation View - Wall Removed

*Patented design

Find your nearest Munters office at www.munters.com

Munters reserves the right to make alterations to specifications, quantities, etc., for production or other reasons, subsequent to publication. © Munters AB, 2021