

Munters VariMax[®] OTH

Indirect-fired gas heaters

Features

- Efficiencies up to 88%
- Indirect gas heat
- All-welded stainless steel heat exchanger
- Gas train and controls available
- Complete packages

The VariMax[®] Once-Through Heater (OTH) is a high-efficiency, industrial, indirect-fired gas heater used to heat process air streams without contaminating the air with the products of combustion. The OTH is particularly useful for recirculating ovens, make-up air applications in cold environments and industrial processes with moderate temperature rises.

The counterflow configuration, four-pass design, and optimized secondary tubular heat exchanger, result in efficiencies up to 88%. The heater uses a Maxon[®] industrial gas burner for clean, reliable combustion. Standard OTH heat exchangers are constructed of heavy-duty stainless steel for strength, durability, and corrosion resistance. Units are available with FM or XL GAP certified gas trains and complete heater controls.

Munters can also provide complete heating packages, including filters, dampers, fans, and duct sections or separate housings.



Munters VariMax[®] OTH

Indirect-fired gas heaters

VariMax description

VariMax OTHs are available in six sizes from 500 to 3,500 MBH, with a minimum 3:1 turndown ratio (exact turndown depends on condensing conditions in the heat exchanger), and are capable of handling airflows from 2,000 to 65,000 scfm. The maximum outlet temperature is 600°F and the maximum temperature rise is 150°F. Efficiencies are in the 70% to 88% range, depending on the flow volume, inlet temperature, and firing rate.

Design features

VariMax OTH features a drum and tube heat exchanger with a four-pass, counterflow design to optimize efficiency. The drum, or firing chamber, is constructed of at least 12 gauge 316L stainless steel for long life under high temperatures. The rest of the heat exchanger is composed of 304L or 316L stainless steel, depending on design temperatures, to provide exceptional durability and resistance to heat and corrosion. Munters is the leader in the design and manufacture of air-to-air tubular heat exchangers and this expertise has been utilized to create a highly efficient secondary tubular heat exchanger. The all welded construction, leak tested for every unit, ensures separation of the products of combustion from the process air stream.

Heat exchangers are “free floating,” to allow for thermal expansion, and mounted either to a 1/4" plate or in a pre-fabricated duct section. The flue gas duct can be attached to the unit via a collared or flanged exhaust connection.

OTH incorporates a Maxon OvenPak[®] gas burner, a reliable burner with many years of service. The burner features a cast iron body, integral combustion air blower and gas control valve, and low turndown ratio. Burners can be mounted with combustion filters, control linkages, and either flame rods or UV scanners. Emissions can be determined via a sampling port that feeds directly off the combustion chamber.

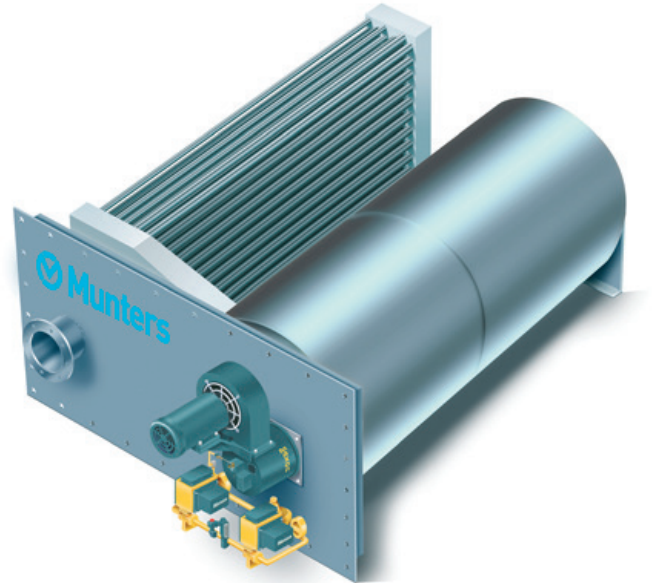

Munters VariMax[®] OTH

Indirect-fired gas heaters

Dimensions and performance

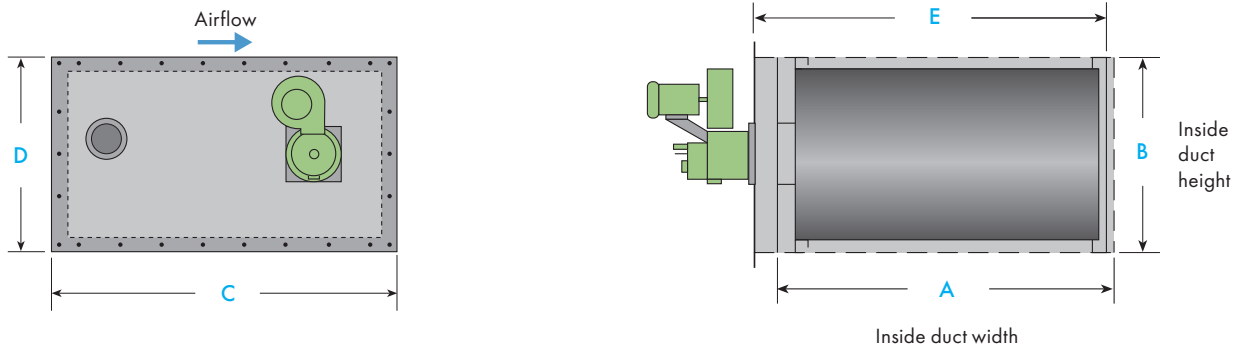

Dimension (inches)	Model					
	OTH - 0500	OTH - 0800	OTH - 1250	OTH - 1750	OTH - 2500	OTH - 3500
A	44.50	53.00	59.79	80.50	103.50	128.50
B	27.00	32.00	46.50	49.00	56.00	66.50
C	53.00	65.50	86.00	86.00	102.00	118.50
D	32.00	37.00	51.50	54.00	61.00	71.50
E	47.96	56.25	62.75	83.50	106.21	130.75
Weight	600 lbs.	800 lbs.	1,100 lbs.	1,350 lbs.	2,000 lbs.	3,610 lbs.

Note: Standard thickness of insulated plug is 4". Consult factory for other thickness. Units can be mirrored for flow from right to left. These dimensions are for reference only and are subject to change without notice. Consult factory for certified drawings. Weight does not include burner or shipping frame.

Nominal performance at 70°F inlet temperature

OTH Model	Input MBH	Output MBH	Min scfm	Max scfm	Process Air Temperature Rise (°F)				
					50	80	100	125	150
					scfm				
0500	590	500	2,000	9,500	9,260	5,790	4,630	3,700	3,090
0800	940	800	3,000	15,000	14,800	9,260	7,410	5,930	4,940
1250	1,470	1,250	4,800	24,000	23,150	14,470	11,570	9,260	7,720
1750	2,060	1,750	7,200	33,000	32,400	20,250	16,200	12,960	10,800
2500	2,940	2,500	10,200	47,000	46,300	28,900	23,150	18,520	15,430
3500	4,120	3,500	14,400	65,000	64,800	40,500	32,400	25,930	21,600

*Units cannot be operated at maximum gas input with minimum scfm.

Munters VariMax[®] OTH

Indirect-fired gas heaters

Configurations

OTH can handle airflows from 2,000 to 65,000 scfm and produce air temperature rises from 20°F to 150°F*, with a maximum outlet temperature of 600°F. The heaters may be placed in series or in parallel as long as the temperature restrictions are not exceeded. Heaters can also be coupled with dampers to provide variable volume systems.

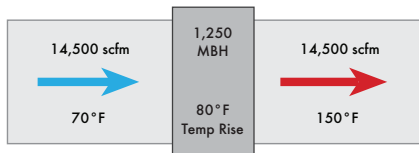

Single

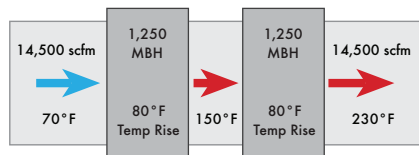

Series

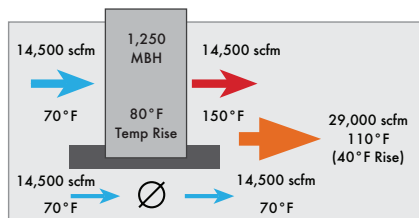

Variable volume

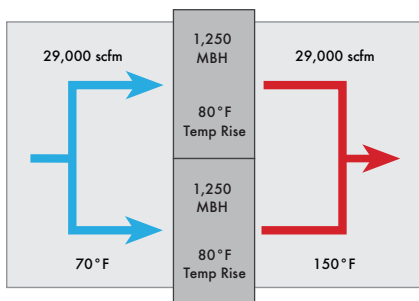

Parallel

Options

OTH can be supplied with a gas train, in either FM or XL GAP configurations, and a complete controls package. It is also available in a mirrored design for flow from right to left and in a pre-packaged, insulated duct section.

As a leader in custom air-handling systems, Munters can also provide complete heating systems including fans, dampers, filters, and controls. Consult factory for details.

Optional: Complete packaged units

Munters can provide complete packaged units incorporating the OTH, as shown below.

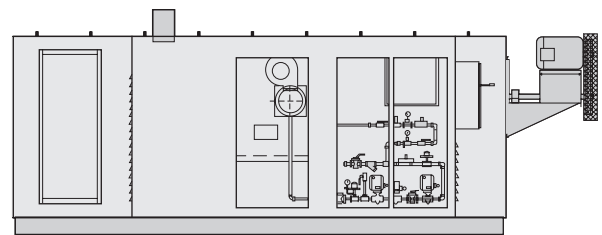

Side view

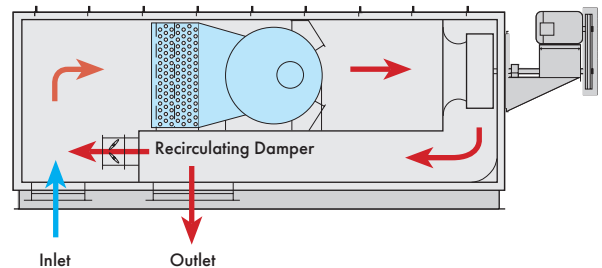

Side section

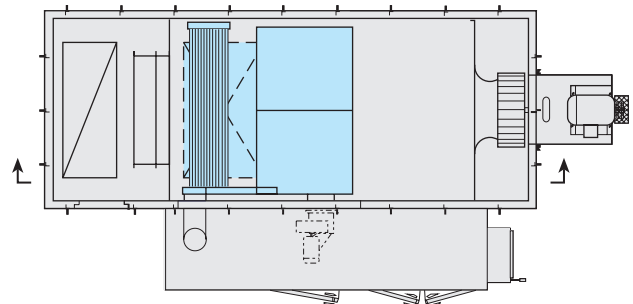

Plan view

See factory regarding distances between heaters.

*If temperature rises greater than 150°F are required, consult Munters for information regarding the VariMax[®] IFRG (Indirect-Fired Recirculating Gas) heater.

Munters VariMax[®] OTH

Indirect-fired gas heaters

Options

Burner options

Filter, silencer, manual handle with locking device or control bracket and linkage (CB&L), high and low fire switches.

Gauge package

Gas pressure gauges for: pilot before regulator (inlet pressure to gas train), pilot after regulator, main after regulator, and main before burner. Includes needle valves and piping.

Gas train and controls options are available with components especially selected for automotive standards; consult factory for details.

FM gas train

One main manual shut-off valve with locking device, one main safety shut-off valve, main pressure regulator, high and low gas

pressure switches, pilot manual shut-off valve, pilot safety shut-off valve, pilot pressure regulator, flame safeguard (flame rod or UV scanner), ignition transformer, and leak test valves.

XL GAP gas train

FM gas train components plus: second safety shut-off valve, vent valve, additional leak test valve, second pilot manual shut-off valve, additional vent piping and couplings.

Control package

Honeywell[®] combustion controller with flame safeguard amplifier, purge timers, temperature controller, burner controller, actuator, high and low fire switches for burner, control transformer, CB&L, electrical panel and all wiring.

Technical specifications

OTH Model	Burner Model	Max Gas Input (MBh)	Gas Inlet Pressure ("W.C.)	Motor HP	Motor Amps for 115/1/60	Motor Amps for 460/3/60
0500	OP 412M (OP LE 10)	600	4.5 (8.1)	½ (1)	9.8 (N/A)	1.1 (2.1)
0800	OP 415 (OP LE 10)	950	4.2 (8.1)	1/3 (1)	7.2 (N/A)	0.7 (2.1)
1250	OP 425 (OP LE 15)	1500	3.6 (8.5)	¾ (1½)	13.8 (20)	1.6 (3.0)
1750	OP 432M (OP LE 25)	2100	4.9 (8.4)	¾ (2)	13.8 (24)	1.6 (3.4)
2500	OP 445M (OP LE 30)	3000	4.5 (8.8)	1 (3)	16 (34)	2.1 (4.8)
3500	OP 470M (OP LE 45)	4200	5.2 (9.2)	2 (5)	N/A (N/A)	3.4 (7.6)

Note: Values in parenthesis are for optional OP-LE Burner.

Find your nearest Munters office at www.munters.com

Munters reserves the right to make alterations to specifications, quantities, etc., for production or other reasons, subsequent to publication. © Munters AB, 2021