



Munters IL 100 / 200 / 300

Air inlets

IL air inlets are designed to be used as ceiling mounted air inlets in livestock structures and they are made of durable white UV stabilized polystyrene. They are suitable for winter and summer months.

Advantages

- Easy installation
- Main flap moulded in 2 pieces preventing deformation
- Main flap has an insulated core, preventing condensation on inside
- Integrated aluminium profiles prevent main door warping
- Main flap has rubber seal on the sides for tight sealing
- Integrated eyelet for supporting of cabling
- Withstands cleaning with a high pressure cleaner



IL Air Inlet

Winter ventilation

A critical time for ventilation of livestock structures is during cold periods, when it is necessary to ventilate the structures to supply fresh air to the animals without causing cold drafts over them; a process commonly known as minimum ventilation. The only way of performing minimum ventilation effectively is by directing the cold fresh air along the ceiling of the structure so that it can mix thoroughly with the hot air inside the structure before it descends into the occupied zone of the animals and replaces the stale air. Failure to perform minimum ventilation effectively could cause a build-up of noxious gases, such as ammonia or carbon dioxide, inside the structure; or, a fatal reduction in oxygen levels. Another problem commonly associated with ineffective minimum ventilation is cold air dropping onto the animals, disturbing animal behaviour. The IL air inlets are designed to perform minimum ventilation perfectly; maintaining a healthy environment for the animals without disrupting normal animal behaviour.

Summer ventilation

During warmer periods the emphasis of ventilation shifts towards heat removal and cooling of the animals. In such conditions the air entering the structure can be directed down towards the animals, allowing heat removal from the animals' skins through a wind chill process. Once again the IL can be adjusted to ensure that the air reaches the animals.



IL Air Inlet mounted into a pig stable.

Munters IL 100 / 200 / 300

Air inlets

Dimensions

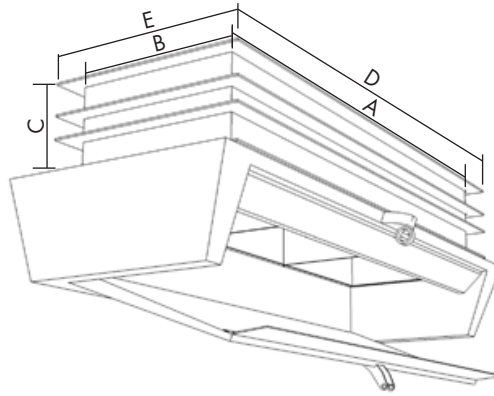

	A	B	C	D	E
IL 200	650 mm	260 mm	150 mm	690 mm	300 mm

Technical specifications

		IL 100	IL 200	IL 300
Air flow 10 Pa	[m ³ /h]	1,320	1,440	1,415
Air flow 20 Pa	[m ³ /h]	1,870	2,015	2,000

Airflow data are measured at standard conditions (20°C, 1,013hPa)

Optimised technology

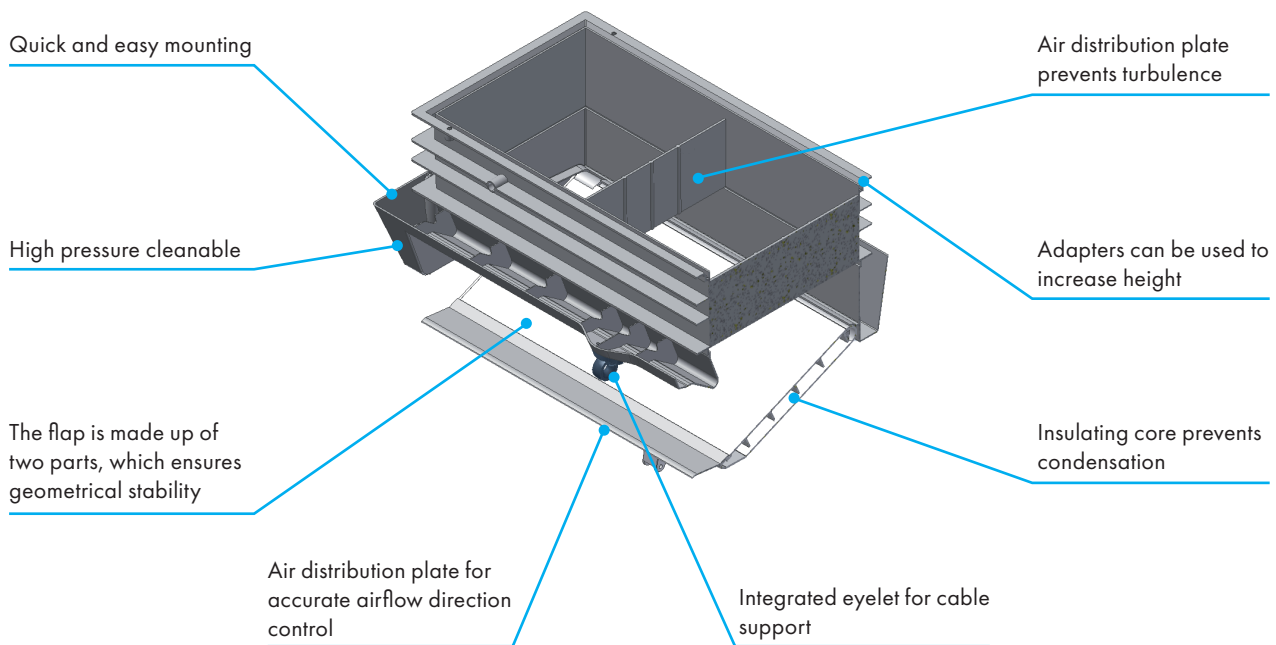

Added benefits

With the use of top grade polystyrene it is possible to maintain hygienic conditions around the animals since the polystyrene has anti soiling properties; is high pressure cleanable; is corrosion resistant; maintains its physical properties for many years; and will withstand temperature extremes and UV radiation. The design of the IL air inlet allows for the precise adjustment of the air distribution pattern to ensure

animal comfort at all times. The insulated main door can be automatically opened and closed to adjust the ventilation rate. An integrated eyelet provides an easy support for the cabling associated with the automatic opening of the inlets. Safety is always an important consideration and therefore the main door opens under gravity, a feature that makes emergency ventilation easily possible in case of power failure.

Find your nearest Munters office at www.munters.com

Munters reserves the right to make alterations to specifications, quantities, etc., for production or other reasons, subsequent to publication. © Munters AB, 2022