



Munters EM 30-36 and ED 24

Air extraction fans

EM 30-36 and ED 24 are among the most well-known exhaust box fans designed and produced by Munters, able to combine high airflow capacity with reliability in any livestock farming (broiler, layer, swine, dairy) and greenhouse application.

Features

- Superior durability with Munters Protect coating, 3 years warranty against corrosion
- Reliable and robust, proven in the market
- High airflow capacity
- Energy efficient solution
- Suited for minimum and tunnel ventilation

Munters EM 30-36 and ED 24 are the ideal exhaust fans whenever a high and stable airflow is required, even in high static pressure environments. They feature the housing, conveyor and shutters made in Munters Protect coated steel for extra strength and resistance against corrosion.

The belt drive system of EM 30-36 enables low speed propeller, which results in reduced energy consumption and noise level, assuring a comfortable environment for both animals and operators. On the other hand, ED 24 is characterized by direct drive motor that provides a high and steady airflow, while making maintenance easier.

The patented centrifugal system provides an energy efficient solution and powerful springs keep shutters tightly closed when the fan is not turned on, avoiding air leakage and blocking light.

As market leader in ventilation solutions for more than 60 years, Munters guarantees quality and is ISO 9001 certified.

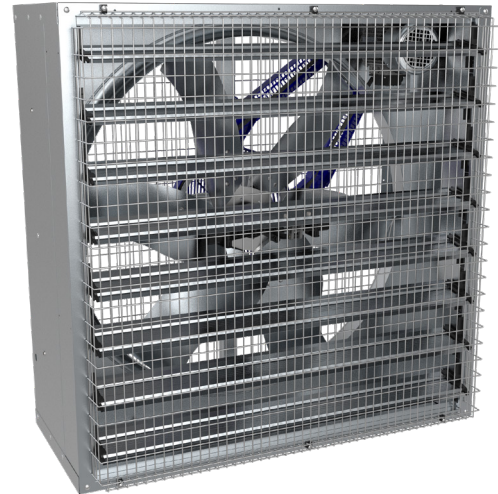

EM36 front view

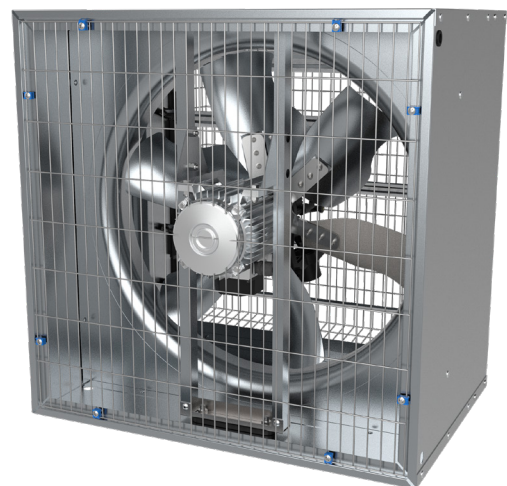

ED24 rear view

Munters EM 30-36 and ED 24

Air extraction fans

Dimensions

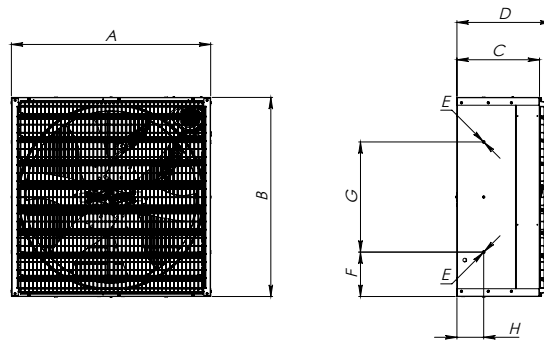

	A	B	C	D	E	F	G	H
EM30	950 mm	950 mm	450 mm	540 mm	M8	240 mm	475 mm	154 mm
EM36	1090 mm	1090 mm	450 mm	520 mm	M8	245 mm	600 mm	145 mm
ED24	750 mm	750 mm	510 mm	640 mm	-	-	-	-

Technical specifications

		EM30		EM36		ED24	
Nominal power	Hp	0.5	0.75	0.5	0.75	1	0.5
Propeller diameter	mm [inch]	770 [30]		915 [36]		660 [24]	
Number of blades/material		6/Munters Protect		6/Munters Protect		6/Munters Protect	
Number of shutter blades		7		8		5	
Transmission		Belt drive		Belt drive		Direct	
Weight of fully equipped fan	kg	55	56	64	65	67	51
Max power consumption/max current ¹	W/A	570/1.1	870/1.6	570/1.1	870/1.6	1150/2.1	790/1.4
Max operating temperature	°C [°F]	50 [122]		50 [122]		50 [122]	
Max operating pressure	Pa	50		50		50	
Motor insulation grade/protective class		F/IP55		F/IP55		F/IP55	
Noise level ²	Db(a)	63.4	66.9	62.1	63.9	68.4	69.5

¹150 Hz 400 V specification, 60 Hz available upon request, ²Noise measure made according to ISO 3744

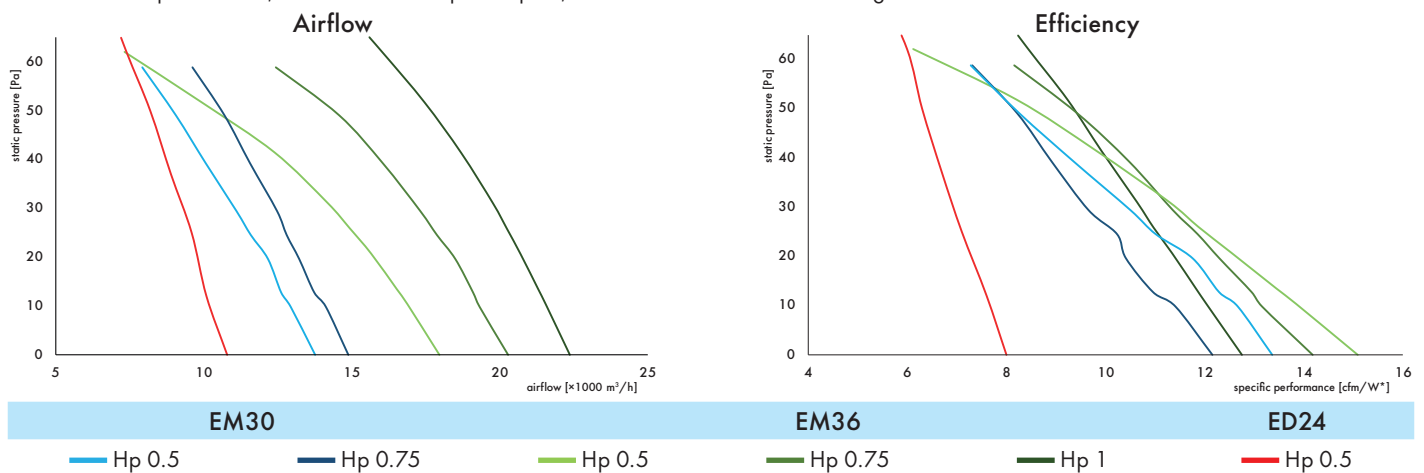

Airflow and efficiency data measured at standard conditions (20°; 1013 hPa). *1 cfm/W = 1.7 m³/hW

Load capacity

	EM36		EM30	ED24
	Unassembled	Assembled	Assembled	Assembled
20' Container	170 (130 ¹)	50	60	55
40' Container	-	104	120	115
40' HC Container	300	104	120	115
Truck	360	120	140	170

Pyramidal mesh for installation below 2.7 m available upon request. ¹With CE plastic protection

Find your nearest Munters office at www.munters.com

Munters reserves the right to make alterations to specifications, quantities, etc., for production or other reasons, subsequent to publication. © Munters AB, 2021