

EQUIPMENT

DF 4200

- High separation efficiency
- Specifically designed for high liquid volume
- Corrosion resistant
- Simple installation
- Low maintenance cost due to simple operating principle and long lifetime
- Wide face velocity range
- Tailor made sizes and designs
- Hygienic design
- Wide range of highest quality material
- In house ISO 9001 certified manufacturing

DF 4200

Droplet Separator

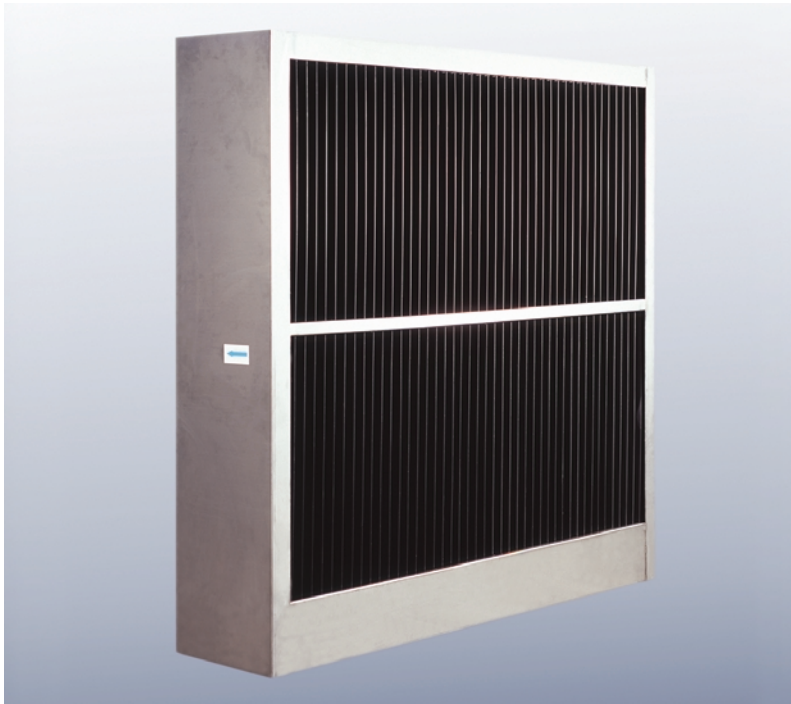

DF 4200 is a ready-to-install droplet separator for use in many application areas. It is available in various material combinations and configurations to fit a wide range of operating conditions.

DF 4200 droplet separator provides high efficiency droplet separation even under harsh operating conditions. The droplet separator can be configured to most individual performance and installation situations, providing a cost effective solution. Alternative material choices and drainage systems, as well as add-on features like flanges and protection mesh are just some of the configuration options.

DF 4200 droplet separator is designed for use in many applications, for example: air washers, spray humidifiers and low velocity air intakes. The unit is suitable for use at face velocities between 1 and 4 m/s.

Separation technology

The streamlined separator deflects the droplet laden gas stream, as a result the momentum of the droplets causes them to impinge onto the profile surface. The droplets coalesce together and form a liquid film, the influence of gravity causes the liquid to drain to the bottom of the profiles. Specially shaped separation chambers improve performance by enhancing the separation of finer droplets and ensuring problem free discharge of liquid.

To avoid “flooding” of the profiles and the possibility of re-entrainment of the separated liquid, the height of the profile sections, droplet separator is normally limited to 2,500 mm.

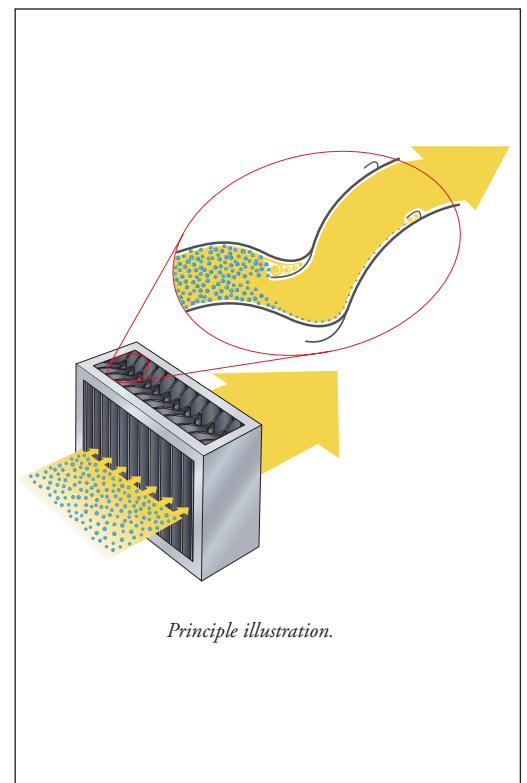

Principle illustration.

Performance

The limit drop size represents a performance characteristic of the profile, at the relevant velocity and operating conditions it is the size of the smallest droplet that is completely separated. The diagram showing limit drop size has been calculated for an air/water system at 20 °C and 1 bar.

The pressure drop is measured at ambient conditions (20 °C and 1 bar) through a number of assembled profiles and under ideal conditions.

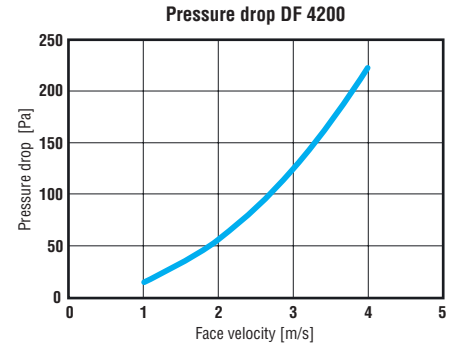
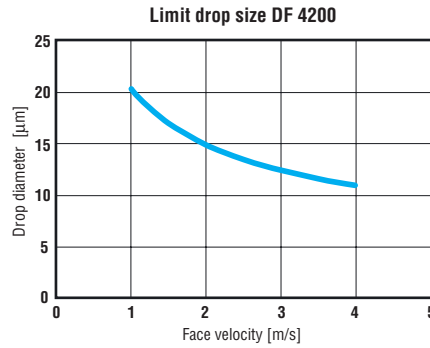

— 25 mm pitch/spacing between profiles

For any data outside the specified range, please contact your nearest Munters representative.

Liquid load

Maximum liquid load; 300 gram water/kg air, measured under ideal conditions at 20 °C, 1 bar and a face velocity of 4.0 m/s with a pitch/spacing of 25 mm between the profiles.

Type, material and dimension specifications

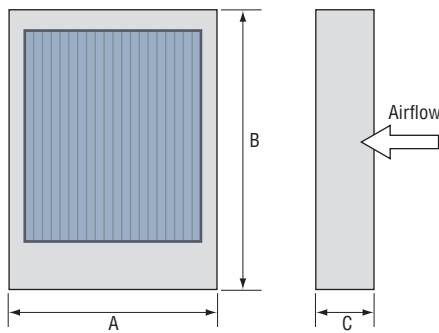

Type code	Material		Pitch/spacing between profiles mm	Width** A mm min-max	Height** B mm min-max	Depth C mm	Operating temp °C min-max
	Frame*	Profile					
1b	304	PPTVb***	25	300-2,500	300-2,500	186	+5 - +100
1w	304	PPTVw	25	300-2,500	300-2,500	186	+5 - +100
3b	316Ti	PPTVb***	25	300-2,500	300-2,500	186	+5 - +100
3w	316Ti	PPTVw	25	300-2,500	300-2,500	186	+5 - +100

PPTV = Talcum reinforced polypropylene (b = black, w = white)
 304 = Stainless steel (AISI 304, DIN 1.4301)
 316Ti = Stainless steel (AISI 316Ti, DIN 1.4571)

* All frames can be painted on request (specify RAL code).

** Standard tolerance on width and height: +0, -5 mm.

*** Special polypropylene compound for min temperature -40 °C on request.

Drainage positions

Code for drainage position, put P before the position number, e.g., P9 or P6,8,9,10 if more outlets are to be used.

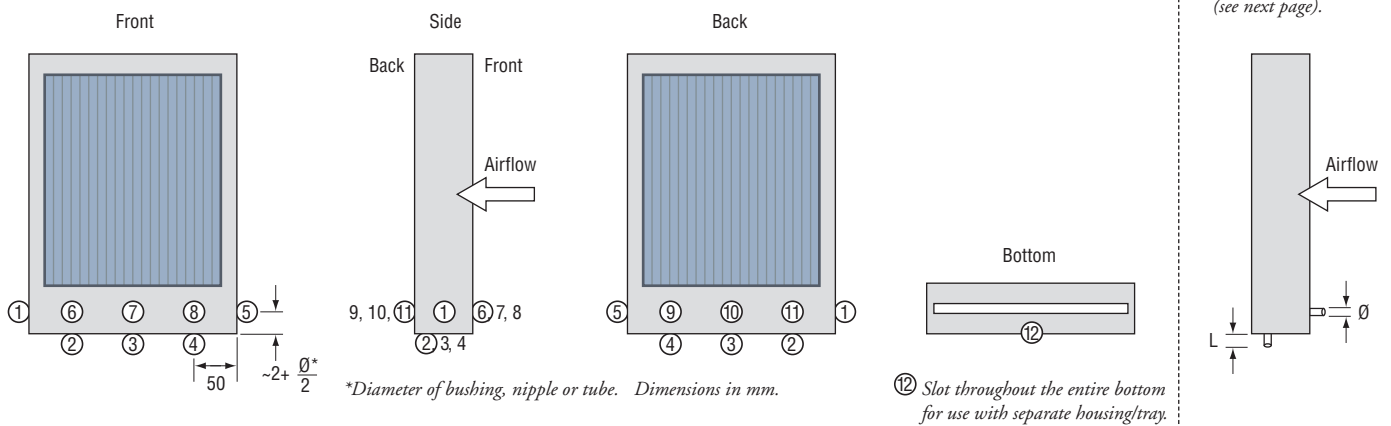

Fittings specifications

For stainless steel frames

Fitting code	Ø inch	L mm
B1	1/2	34
B2	3/4	36
B3	1	43
B4	1 1/2	48
B5	2	56
B6	2 1/2	70
B7	3	95

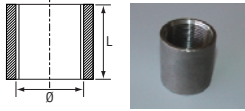

Fitting code	Ø inch	L mm
C1	1/2	15
C2	3/4	17
C3	1	19
C4	1 1/2	22
C5	2	26

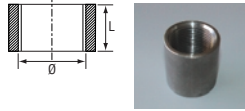

Fitting code	Ø inch	L mm
D1	1/2	35
D2	3/4	40
D3	1	40
D4	1 1/2	50
D5	2	50
D6	2 1/2	60
D7	3	65

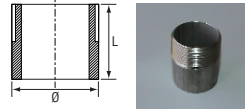

Fitting code	Ø inch	L mm
E1	1/2	25
E2	3/4	40
E3	1	35
E4	1 1/2	38
E5	2	45

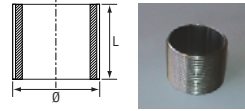

Bushing according to DIN 2986, nipples DIN 2982, material 316Ti (AISI 316Ti, DIN 1.4571), witworth – thread according to DIN 259.

* In combination with bushing (fitting code B).

N.B. The required cross-section of the water outflow depends on both application and liquid load. Most frequently used fitting sizes are 3/4" and 1" and corresponding tube sizes.

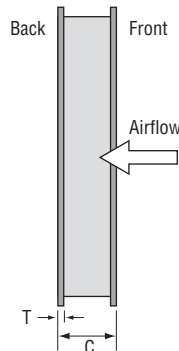
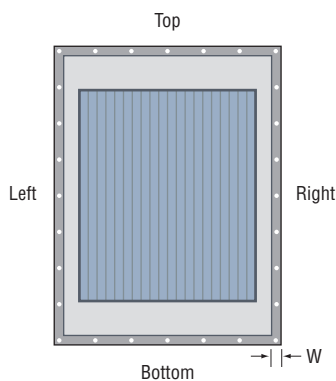

Hole configurations in flanges are delivered according to Eurovent, DIN 24193, Norsok or other trade, national or international standards (specify according to individual requirements are also delivered (specify drill pattern and hole diameter, provide drawing or use sketch on last page).

N.B. Depths [C] is the same with or without flanges.

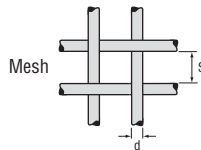
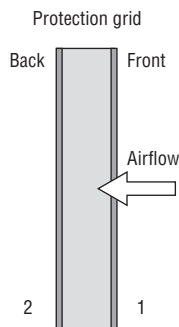

Flanges specifications

Flange code		Position	Thickness*, T	
Continuous welded	Spot welded		code	mm
F1	F11	Top & bottom front	T2	2
F2	F12	Left & right front	T3	3
F3	F13	All sides front	T5	5
F4	F14	Top & bottom back	T8	8
F5	F15	Left & right back	Width*, W	
F6	F16	All sides back		
F7	F17	Top & bottom, front & back	code	mm
F8	F18	Left & right, front & back	W30	30
F9	F19	All sides front & back	W50	50
			W60	60

Material: Stainless steel in accordance with the frame material selected.

* Other thickness or width on request.

Protection grid and mesh type specifications

Protection grid code	Position	Mesh width, S		Mesh type, wire diameter, d Ø [mm]			
		inch	mm	1.0	1.2	1.5	2.0
G1	Front	1/4 x 1/4	5 x 5	Q1			
G2	Back	1/4 x 1/4	6 x 6	Q2	X2		
		1/3 x 1/3	8 x 8	Q3	X3		
		1/2 x 1/2	10 x 10	Q4	X4		
		1/2 x 1/2	12 x 12	Q5		Y5	
		3/4 x 3/4	16 x 16	Q6	X6	Y6	
		3/4 x 3/4	20 x 20	Q7		Y7	Z7
		1 x 1	25 x 25			Y8	Z8

Material: Stainless steel 304 (AISI 304, DIN 1.4301).

N.B. Protection grid is mainly used as trash screen on air inlets. Pressure drop over wire mesh is negligible.

DF 4200

DF 4200 droplet separator is developed to suit a wide range of applications. The various outfit options cover the most typically occurring installation variations. However, tailor made droplet separators are frequently delivered based on customers' individual specifications.

Material certificates can be delivered for most materials upon request.

For hygienic-proof HVAC equipment DF 4200 droplet separator can be delivered in accordance with the standards VDI 6022, VDI 3803, DIN 1946 (specify H in order code).

DF 4200 is developed and produced by Munters Euroform GmbH, Germany.

Order information

DF 4200-X-X-X-X-X-X-X-X-X-X-X-X

Type code	_____	_____
Pitch/spacing, mm	-----	-----
Width, mm	_____	_____
Height, mm	-----	-----
Options	Drainage position(s) code	_____
	Fitting code	-----
	Flange position code	_____
	Flange thickness code	-----
	Flange width code	_____
	Protection grid position(s) code	-----
	Mesh type code	_____
	Hygienic design code	-----

e.g., DF 4200-1b-25-1820-1200-P9-B5-F2-T2-W30-G2-Q4-H

Examples of installation

1. The droplet separator is flanged onto a wall opening and the water drains vertically outside of the wall.
2. The droplet separator is flanged into a wall opening and the water drains controlled into an internal tray (not shown in the drawing)
3. The droplet separator is installed in an air duct and stands in between angled profiles that are connected to the air duct. The water drains through the bottom into a tray that is below the air duct.

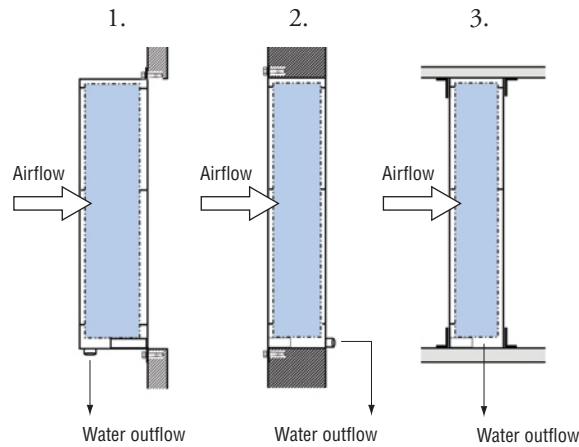

Drill pattern sketch

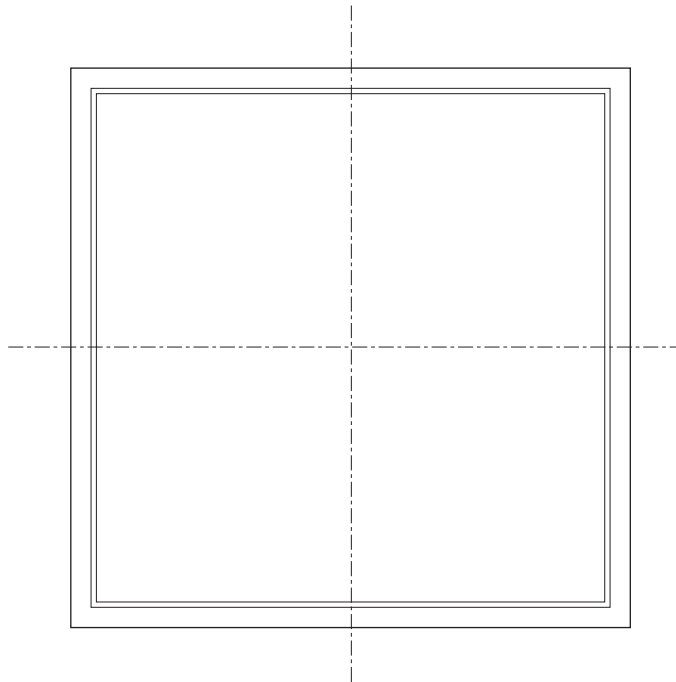

Munters Europe AB, HumiCool Division, Kung Hans Väg 8, P O Box 434, SE-191 24 Sollentuna, Sweden. Phone +46/(0)8/626 63 00, Fax +46/(0)8/754 56 66.
Munters Euroform GmbH, Süsterfeldstrasse 65, PO Box 1089, DE-52011 Aachen, Germany. Phone +49/(0)241/89 00 0, Fax +49/(0)241/89 00 199.

www.munters.com

Austria via sales organization in Germany, Munters Euroform GmbH, Phone +49/(0)241/89 00 0, Fax +49/(0)241/89 00 199, **Denmark** via sales organization in Sweden, Munters Europe AB, Phone +46/(0)8/626 63 00, Fax +46/(0)8/754 56 66, **Finland** Munters Oy, Phone +358/(0)9/83 86 0330, Fax +358/(0)9/83 86 0336, **France** Munters France S.A., Phone +33/(0)1/34 11 57 50, Fax +33/(0)1/34 11 57 51, **Germany** Munters Euroform GmbH, Phone +49/(0)241/89 00 0, Fax +49/(0)241/89 00 199, **Italy** Munters S.R.L., Phone +39/(0)2/488 6781, Fax +39/(0)2/488 1171, Munters euroemme S.p.A., Phone +39/(0)183/52 11, Fax +39/(0)183/521 333, **Kingdom of Saudi Arabia and Middle East** Hawa Munters, c/o Hawa United Cooling Syst. Co. Ltd., Phone +966/(0)1/477 15 14, Fax +966/(0)1/476 09 36, **Norway** via sales organization in Sweden, Munters Europe AB, Phone +46/(0)8/626 63 00, Fax +46/(0)8/754 56 66, **South Africa & Sub-Sahara Countries** Munters (Pty) Ltd, Phone +27/(0)11/455 2550/1/2, Fax +27/(0)11/455 2553, **Spain** Munters Spain S.A., Phone +34/91/640 09 02, Fax +34/91/640 11 32, **Sweden** Munters Europe AB, Phone +46/(0)8/626 63 00, Fax +46/(0)8/754 56 66, **Switzerland** via sales organization in Germany, Munters Euroform GmbH, Phone +49/(0)241/89 00 0, Fax +49/(0)241/89 00 199, **United Kingdom** Munters Ltd, Phone +44/(0)1480/442 340, Fax +44/(0)1480/411 332, **Export & Other countries** Munters Europe AB Phone +46/(0)8/626 63 00, Fax +46/(0)8/754 56 66, **Region Americas** Munters Corporation, Phone +1/(0)978 241 1100, Fax +1/(0)978 241 1214, **Region Asia** Munters K.K., Phone +81/(0)3/5970 0021, Fax +81/(0)3/5970 3197

Munters reserves the right to make alterations to specifications, quantities, etc., for production or other reasons, subsequent to publication.

© Munters Europe AB, 2003