

## EQUIPMENT

# DF 3800

- High separation efficiency
- Extremely thin design (65–70 mm)
- Very low pressure drop leading to lower operating costs
- Corrosion resistant
- Very easy installation
- Low maintenance cost due to simple operating principle and long lifetime
- Wide face velocity range
- Tailor made sizes and designs
- Hygienic design
- Wide range of highest quality material
- In house ISO 9001 certified manufacturing

# DF 3800

## Droplet Separator



DF 3800 is a ready-to-install droplet separator for use in many application areas. It is available in stainless steel and aluminium combinations and configurations to fit a wide range of operating conditions.

DF 3800 droplet separator provides high efficiency droplet separation and extreme low pressure drop even at medium face velocities giving energy saving operation.

The droplet separator can be configured to most individual performance and installation situations, providing a cost effective solution. Alternative material choices and drainage systems, as well as add-on features like flanges and protection mesh are just some of the configuration options.

DF 3800 droplet separator is an excellent choice for keeping rain, mist and larger fog water droplets out of building or marine ventilation systems. This helps to reduce corrosion, to increase filter lifetime and to reduce moisture throughout the system.

DF 3800 droplet separator is designed for use in many applications and for an easy integration into the superstructure. The unit is suitable for use at face velocities between 1 and 4 m/s.

### Separation technology

The streamlined separator deflects the droplet laden gas stream, as a result the momentum of the droplets causes them to impinge onto the profile surface. The droplets coalesce together and form a liquid film, the influence of gravity causes the liquid to drain to the bottom of the profiles. Specially shaped separation chambers improve performance by enhancing the separation of finer droplets and ensuring problem free discharge of liquid.

To avoid “flooding” of the profiles and the possibility of re-entrainment of the separated liquid, the height of the profile sections, droplet separators is normally limited to 2,500 mm.

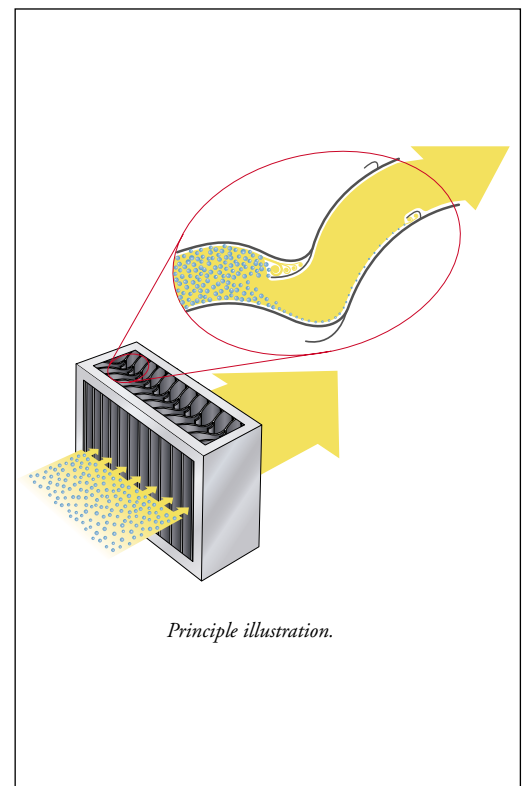

*Principle illustration.*

## Performance

The limit drop size represents a performance characteristic of the profile, at the relevant velocity and operating conditions it is the size of the smallest droplet that is completely separated. The diagram showing limit drop size has been calculated for an air/water system at 20 °C and 1 bar.

The pressure drop is measured at ambient conditions (20 °C and 1 bar) through a number of assembled profiles under ideal conditions.

The fractional efficiency indicates the percentage of droplets, removed from an airstream, that are smaller than the limit drop size.

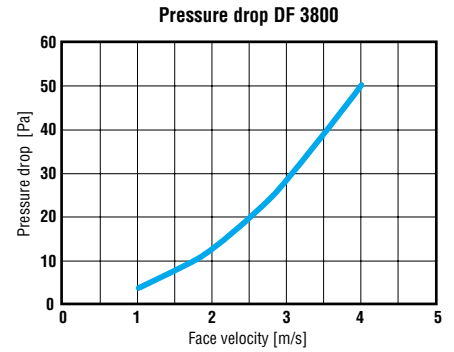
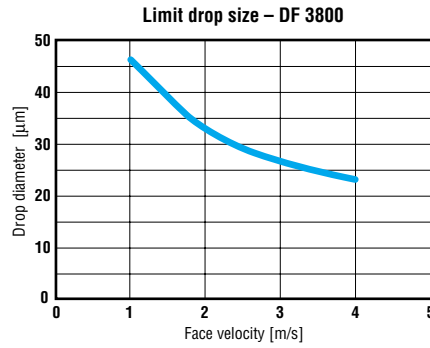

For any data outside the specified range, please contact your nearest Munters representative.

## Liquid load

Maximum liquid load is fully sufficient for removing rain and spray completely under even harsh weather conditions.

## Type, material and dimension specifications

| Type code | Material |            | Width***<br>A mm<br>min-max | Height***<br>B mm<br>min-max | Depth<br>C mm | Operating temp °C<br>min-max |
|-----------|----------|------------|-----------------------------|------------------------------|---------------|------------------------------|
|           | Frame**  | Profile    |                             |                              |               |                              |
| 8a        | AlMg3*   | AlMgSi0.5* | 300-2,500                   | 300-2,500                    | 65-70         | -                            |
| 9m        | 304      | 304        | 300-2,500                   | 300-2,500                    | 65-70         | -                            |
| 9l        | 316L     | 316L       | 300-2,500                   | 300-2,500                    | 65-70         | -                            |
| 9s        | 316Ti    | 316Ti      | 300-2,500                   | 300-2,500                    | 65-70         | -                            |

AlMg3 = Aluminium alloy

AlMgSi0.5 = Aluminium alloy

304 = Stainless steel (AISI 304, DIN 1.4301)

316L = Stainless steel (AISI 316L, DIN 1.4404)

316Ti = Stainless steel (AISI 316Ti, DIN 1.4571)

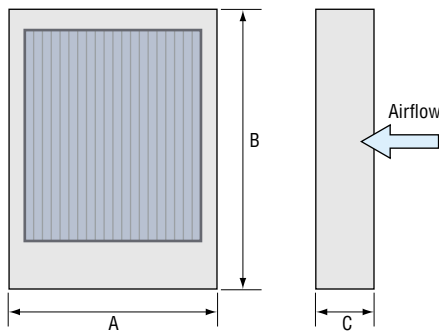

- \* Anodised or coloured material on request.
- \*\* All frames can be painted on request (specify RAL code).  
All frames powder coated on request.  
Aluminium frames of other aluminium alloys on request.  
All frames can be brushed to give a frosted appearance, stainless steel can be obtained polished.
- \*\*\* Standard tolerance on width and height: +0, -5 mm.  
Materials specified are standard - other materials on request).

## Drainage positions

Code for drainage position, put P before the position number, e.g., P9 or P6,8,9,10 if more outlets are to be used.

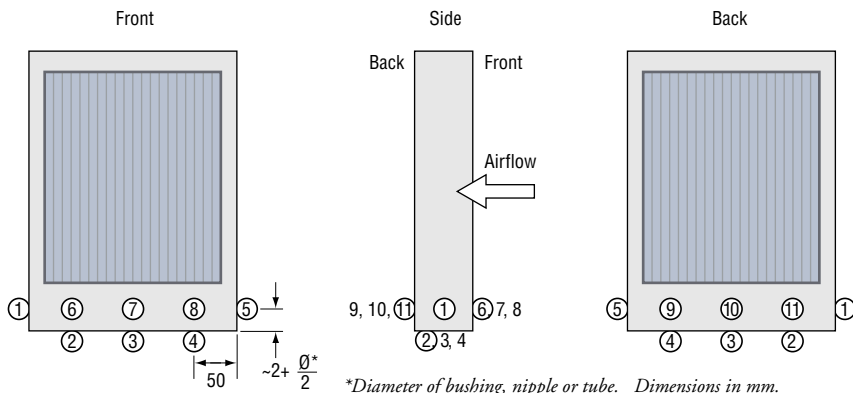

Drawing for fittings (see next page).

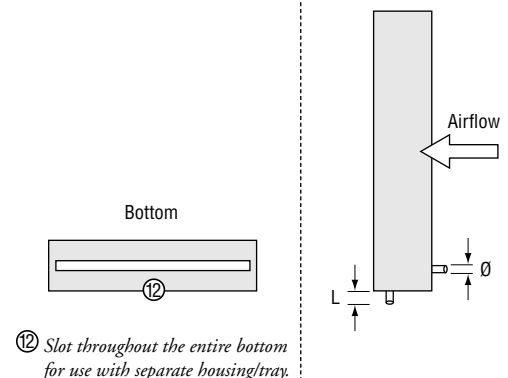

# Fittings specifications

## For aluminium frames

### Tubes

| Fitting code | Ø mm | L mm |
|--------------|------|------|
| A1           | 16   | 50   |
| A2           | 20   | 50   |
| A3           | 30   | 50   |
| A4           | 42   | 50   |
| A5           | 54   | 75   |
| A6           | 65   | 75   |
| A7           | 76   | 75   |

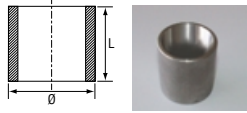

Fitting material AlMgSi0.5 aluminium alloy.

## For stainless steel frames

### Bushing

| Fitting code | Ø inch | L mm |
|--------------|--------|------|
| B1           | 1/2    | 34   |
| B2           | 3/4    | 36   |
| B3           | 1      | 43   |
| B4           | 1 1/2  | 48   |
| B5           | 2      | 56   |
| B6           | 2 1/2  | 70   |
| B7           | 3      | 95   |

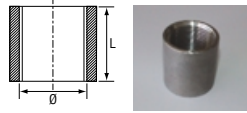

Bushing according to DIN 2986, nipples DIN 2982, material 316Ti (AISI 316Ti, DIN 1.4571), witworth – thread according to DIN 913. \* In combination with bushing (fitting code B).

### Half bushing

| Fitting code | Ø inch | L mm |
|--------------|--------|------|
| C1           | 1/2    | 15   |
| C2           | 3/4    | 17   |
| C3           | 1      | 19   |
| C4           | 1 1/2  | 22   |
| C5           | 2      | 26   |

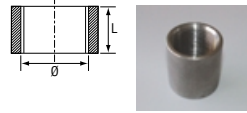

### Weld-on nipple

| Fitting code | Ø inch | L mm |
|--------------|--------|------|
| D1           | 1/2    | 35   |
| D2           | 3/4    | 40   |
| D3           | 1      | 40   |
| D4           | 1 1/2  | 50   |
| D5           | 2      | 50   |
| D6           | 2 1/2  | 60   |
| D7           | 3      | 65   |

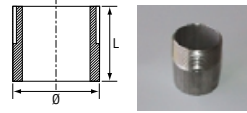

### Nipple\*

| Fitting code | Ø inch | L mm |
|--------------|--------|------|
| E1           | 1/2    | 25   |
| E2           | 3/4    | 40   |
| E3           | 1      | 35   |
| E4           | 1 1/2  | 38   |
| E5           | 2      | 45   |

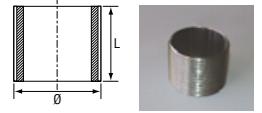

N.B. The required cross-section of the water outflow depends on both application and liquid load. Most frequently used fitting sizes are 3/4" and 1" and corresponding tube sizes.

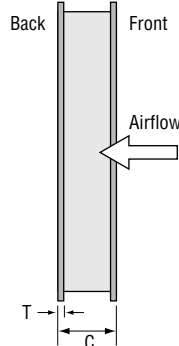
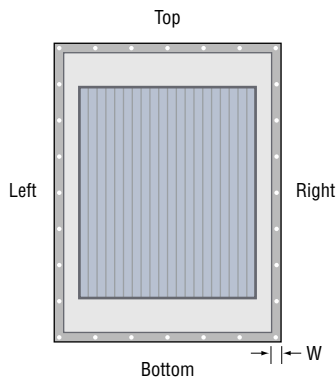

N.B. Depths [C] is the same with or without flanges.

Hole configurations in flanges are delivered according to Eurovent, DIN 24193, Norsok or other trade, national or international standards (specify according to individual requirements are also delivered (specify drill pattern and hole diameter, provide drawing or use sketch on last page).

| Code | [mm] min-max |
|------|--------------|
| R    | 50-500       |



Code for radius, put R before the dimension, e.g. R150

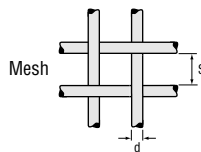
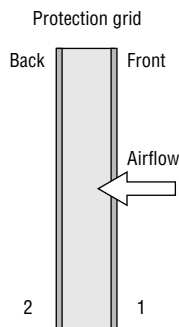

## Flanges specifications

| Flange code       |             | Position                   | Thickness*, T |    |
|-------------------|-------------|----------------------------|---------------|----|
| Continuous welded | Spot welded |                            | code          | mm |
| F1                | F11         | Top & bottom front         | T2            | 2  |
| F2                | F12         | Left & right front         | T3            | 3  |
| F3                | F13         | All sides front            | T5            | 5  |
| F4                | F14         | Top & bottom back          | T8            | 8  |
| F5                | F15         | Left & right back          | Width*, W     |    |
| F6                | F16         | All sides back             | code          | mm |
| F7                | F17         | Top & bottom, front & back | W30           | 30 |
| F8                | F18         | Left & right, front & back | W50           | 50 |
| F9                | F19         | All sides front & back     | W60           | 60 |

Material: Aluminium and stainless steel in accordance with the frame material selected. \* Other thickness or width on request.

## Protection grid and mesh type specifications

| Protection grid code | Position | Mesh width, S |         | Mesh type, wire diameter, d Ø [mm] |     |     |     |
|----------------------|----------|---------------|---------|------------------------------------|-----|-----|-----|
|                      |          | inch          | mm      | 1.0                                | 1.2 | 1.5 | 2.0 |
| G1                   | Front    | 1/4 x 1/4     | 5 x 5   | Q1                                 |     |     |     |
| G2                   | Back     | 1/4 x 1/4     | 6 x 6   | Q2                                 | X2  |     |     |
|                      |          | 1/3 x 1/3     | 8 x 8   | Q3                                 | X3  |     |     |
|                      |          | 1/2 x 1/2     | 10 x 10 | Q4                                 | X4  |     |     |
|                      |          | 1/2 x 1/2     | 12 x 12 | Q5                                 |     | Y5  |     |
|                      |          | 3/4 x 3/4     | 16 x 16 | Q6                                 | X6  | Y6  |     |
|                      |          | 3/4 x 3/4     | 20 x 20 | Q7                                 |     | Y7  | Z7  |
|                      |          | 1 x 1         | 25 x 25 |                                    |     | Y8  | Z8  |

Material: Stainless steel 304 (AISI 304, DIN 1.4301). N.B. Protection grid is mainly used as trash screen on air inlets. Pressure drop over wire mesh is negligible. Aluminium grids can be delivered on request.

## DF 3800

DF 3800 droplet separator is developed to suit a wide range of applications. The various outfit options cover the most typically occurring installation variations. However, tailor made droplet separators are frequently delivered based on customers' individual specifications.

Material certificates can be delivered for most materials upon request. Fractional efficiency curves for given face velocities are delivered on special request.

For hygienic-proof HVAC equipment DF 3800 droplet separator can be delivered in accordance with the standards VDI 6022, VDI 3803, DIN 1946 (specify H in order code).

DF 3800 is developed and produced by Munters Euroform GmbH, Germany.

## Order information

DF 3800-X-X-X-X-X-X-X-X-X-X-X

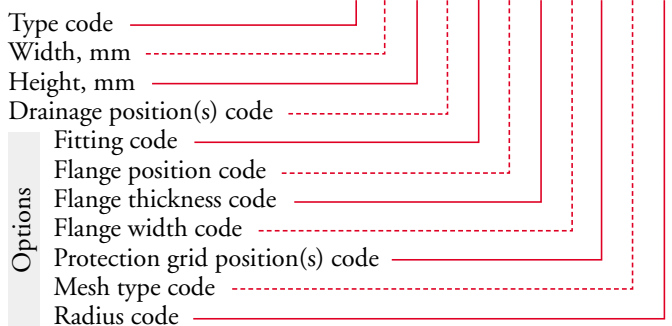

e.g., DF 3800-8a-1820-1200-P9-A5-F2-T2-W30-G2-Q4-R150

## Examples of installation

1. The droplet separator is flanged onto a wall opening and the water drains vertically outside of the wall.
2. The droplet separator is flanged into a wall opening and the water drains controlled into an internal tray (not shown in the drawing)
3. The droplet separator is installed in an air duct and stands in between angled profiles that are connected to the air duct. The water drains through the bottom into a tray that is below the air duct.
4. Galvanic separation of carbon steel structure from the mist eliminator (made of stainless or aluminium).

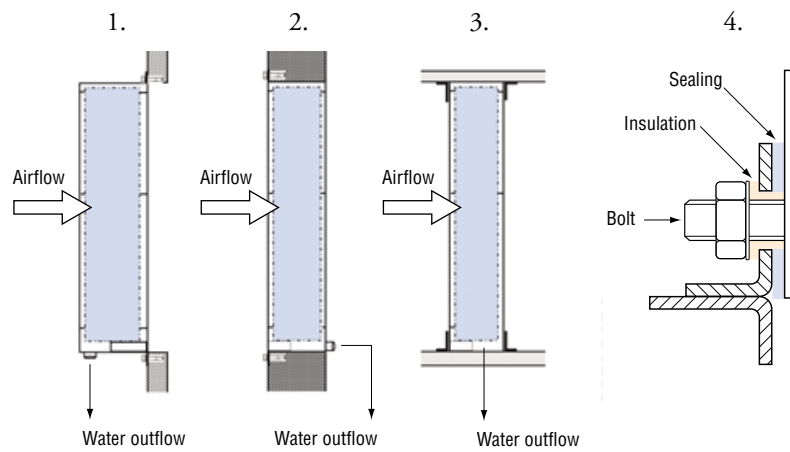

## Drill pattern sketch

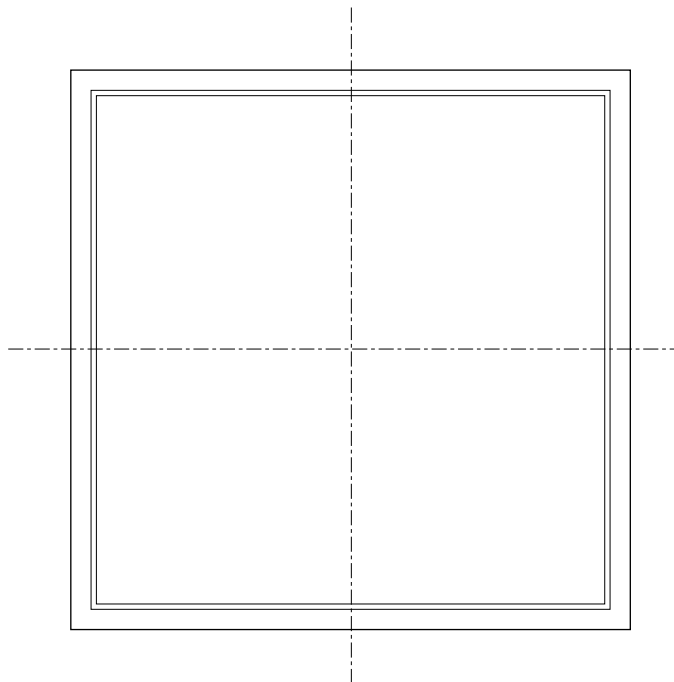

Munters Europe AB, HumiCool Division, Kung Hans Väg 8, P.O. Box 434, SE-191 24 Sollentuna, Sweden. Phone +46 (0)8-626 63 00, Fax +46 (0)8-754 56 66.  
Munters Euroform GmbH, Philipsstrasse 8, DE-52068 Aachen, Germany. Phone +49 (0)241-89 000, Fax +49 (0)241-89 00 199.

[www.munters.com](http://www.munters.com)

**Austria** via sales organization in Germany, Munters Euroform GmbH, Phone +49 (0)241-89 000, Fax +49 (0)241-89 00 199, **Denmark** via sales organization in Sweden, Munters Europe AB, Phone +46 (0)8-626 63 00, Fax +46 (0)8-754 56 66,  
**Finland** Munters Oy, Phone +358 (0)9-83 86 0330, Fax +358 (0)9-83 86 0336, **France** Munters France S.A., Phone +33 (0)1-34 11 57 50, Fax +33 (0)1-34 11 57 51,  
**Germany** Munters Euroform GmbH, Phone +49 (0)241-89 000, Fax +49 (0)241-89 00 199, **Italy** Munters euroemme S.p.A., Phone +39 0183-52 11, Fax +39 0183-521 333,  
**Kingdom of Saudi Arabia and Middle East** Hawa Munters, c/o Hawa United Cooling Syst. Co. Ltd., Phone +966 (0)1-477 15 14, Fax +966 (0)1-476 09 36, **Norway** via sales organization in Sweden, Munters Europe AB,  
Phone +46 (0)8-626 63 00, Fax +46 (0)8-754 56 66, **South Africa & Sub-Sahara Countries** Munters (Pty) Ltd, Phone +27 (0)11-971 9700, Fax +27 (0)11-971 9701, **Spain** Munters Spain S.A., Phone +34 91-640 09 02,  
Fax +34 91-640 11 32, **Sweden** Munters Europe AB, Phone +46 (0)8-626 63 00, Fax +46 (0)8-754 56 66, **Switzerland** via sales organization in Germany, Munters Euroform GmbH, Phone +49 (0)241-89 000, Fax +49 (0)241-89 00 199,  
**United Kingdom** Munters Ltd, Phone +44 (0)845-644 3980, Fax +44 (0)845-644 3981, **Export & Other countries** Munters Europe AB Phone +46 (0)8-626 63 00, Fax +46 (0)8-754 56 66,  
**Region Americas** Munters Corporation, Phone +1 (0)978-241 1100, Fax +1 (0)978-241 1219, **Region Asia** Munters K.K., Phone +81 (0)3-5970 0021, Fax +81 (0)3-5970 3197.

Munters reserves the right to make alterations to specifications, quantities, etc., for production or other reasons, subsequent to publication.

© Munters Europe AB, 2005