



# Munters Exhaust air duct

## Exhaust air systems

The contaminated stable air is optimally transported outside with the proven ventilation system. Irrespective of the individual farm size, the meets all requirements for an efficient exhaust air system. That saves energy and provides for animal-friendly climate.

### ADVANTAGES

- Large selection of duct diameters from 370mm (14,5 inch) to 1,270 mm (50 inch)
- Air capacity from 5,000 m<sup>3</sup>/h (2,900 cfm) up to 52,000 m<sup>3</sup>/h (30,600 cfm)
- Sound reduction with the Munters duct silencer up to 12 dB(A)
- Perfect insulation of 0.022W/mK to avoid condensation
- Covering layers made from reinforced polyester, chemical resistant and easy to clean
- Extensive components programme



The ducting system is comprised of a „sandwich construction“ with highly insulated polyurethane rigid foam in the core and a hard GRP outer and inner coating. Perfect insulation impedes the formation of condensation water.

The air duct is available in lengths of 1,000 mm (39,4 inch) and 1,500 mm (59,1 inch). At 1,500 mm (59,1 inch), fewer adhesive joints are required, which shortens the installation pro-cess. In addition to our extensive duct portfolio, scope of service includes the most important components for efficient exhaust air conveyance:

- Diffusers
- Roofing panels
- Economical fans as module cartridge
- Module seal flaps
- Intake nozzles, etc.

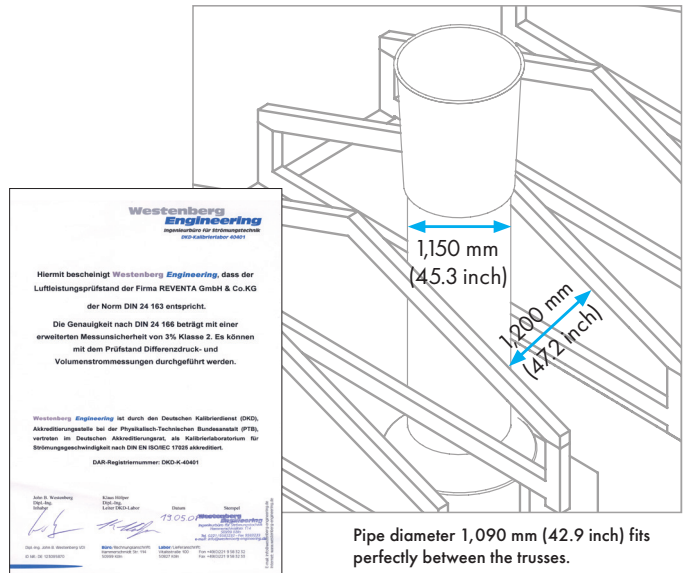

Pipe diameter 1,090 mm (42.9 inch) fits perfectly between the trusses.

Tested on the certified Munters test bench

### Extras + accessories



Formed pieces/curve



Light trap

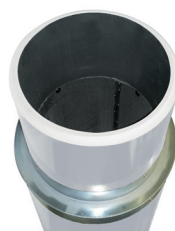

Duct silencers



PU adaptor ring Transition "Full duct" to AGROFLEX® and »vario-clip«



Shutter module with measuring fan

# Munters Exhaust air duct

## Exhaust air systems

### The duct system »AGROFLEX«®



With groove and tongue system

The »AGROFLEX«® duct system comprises of a "sandwich construction" with a highly insulated polyurethane rigid foam at the core and a rigid GRP exterior and interior coating. It is available in the lengths 1,000 mm (39,4 inch) and 1,500 mm (59 inch) and duct diameters 370 (14,6 inch) to 1,270 mm (50 inch).

- Air capacity: 5,000 – 52,000 m<sup>3</sup>/h (2,900 – 36,600 cfm) [0 Pa]
- Lengths 1,000 mm (39,4 inch) and 1,500 mm (59 inch)
- No condensation
- Easy to install
- Hygienically cleaned easily
- Safety through the »Pro assembly kit«

### The duct system »vario clip«®



With groove and tongue system

That transport-optimised variant of the »AGROFLEX«® system: As half-pipe segments, the transportation volume of the pipes is reduced by more than 50%. The segments are »clipped« without additional duct clips or duct clips by means of a PVC profile.

- Safe clip connection
- Easy to assemble
- Reduction of the transport volume by up to 50%!

### Optionally available:

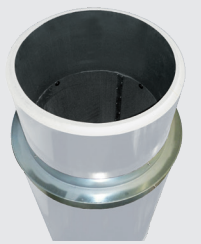

#### Duct silencers

It reduces the sound pressure level demonstrably by up to 12 dB(A)! Already 3 dB(A) means a reducing the perceived loudness.

- TÜV tested
- Retrofitting in existing exhaust air duct systems possible



#### Light trap

The light trap is made of high quality plastic and it reduces the penetration of daylight. Due to the special geometry, the air flow is reduced by only 10 – 15% depending on the fan.

- From high quality, durable plastic profiles
- For all air duct diameters
- Flow optimised geometry

### Pro assembly kit

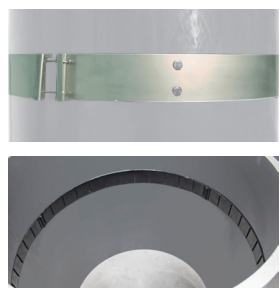

The assembly kit Pro comprises an HP segment ring, which is installed inside the duct and a duct clamp, which is attached from outside via the duct connection. As such the duct joint connections are also better protected with frequent cleaning. There is no need to seal the duct on the inside.

- Highly robust
- Rapid assembly
- Adapter for all duct diameters
- Few parts

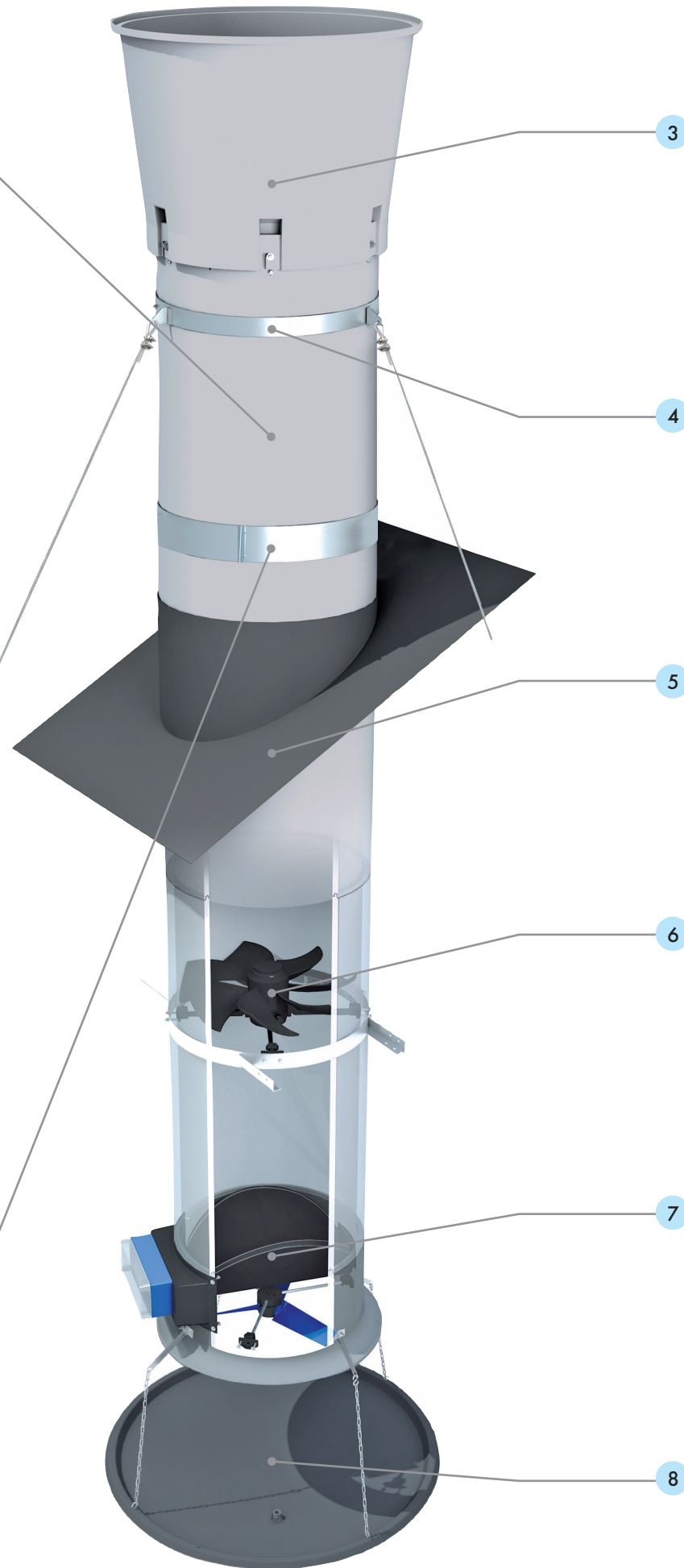

### 3 Intake nozzle and diffuser

The airflow is optimally guided through the diffuser and intake nozzle. In the diffuser, the new contour with integrated support points provides for an even simpler assembly.

- Increase of the air flow by up to 15%
- This means an energy saving of up to 15%



### 4 Anchoring ring and storm bracing

With the anchoring ring and the suitable bracing, each static-prescribed bracing can be implemented reliably.

- We would be happy to support you with the precise planning and development of your respective project.

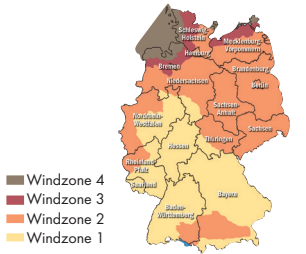

Windzone 4  
Windzone 3  
Windzone 2  
Windzone 1

### 5 GFK roofing panel

The roofing panel made of UV-stabilised, glass fibre reinforced polyester is specifically adapted to the existing roof.

- Appropriate aesthetics and leak-tightness (approved in accordance with DIN E 12691)

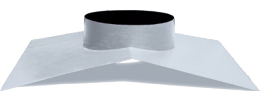

### 6 »Fan module« fan cartridge

Completely pre-assembled module for duct diameters 420 – 1,270 mm (16,5 – 50 inch) / 5,000 – 52,000 m<sup>3</sup>/h (2,900 – 30,600 cfm) [0 Pa] with integrated fan ready for connection. Also available with integrated intake nozzle.

- Increases the air capacity
- For a reduction in costs during planning and assembly
- Easily cleaned



### 7 Shutter module MVSK with measuring fan

As a measuring and throttling unit in the exhaust air duct. The measuring fan is universally usable on every suitable climate computer and measures the exact airflow of every exhaust air unit.

- Better climate control
- Optimal exhaust air rate
- Higher saving potential



### 8 Water collecting basin

As UV-stabilisiertem, glasfaser-verstärktem Polyester zum Aufhängen unterhalb des Lüftungsrohres.

- Collects penetrating water
- Optional with drain for the easy draining of water



# Munters Exhaust air duct

## Exhaust air systems

»AGROFLEX«® – duct (3 m / 9,8 ft) with PUR intake nozzle, diffuser and shutter

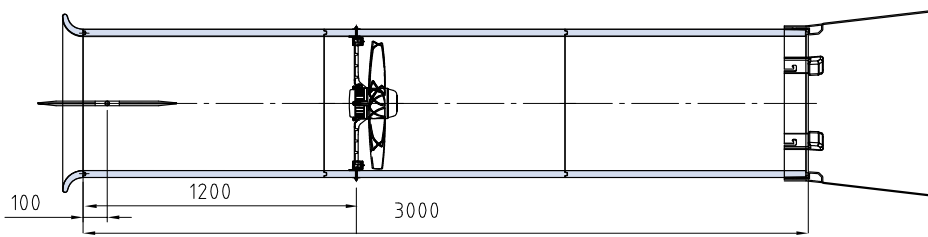

Connection circuit diagram

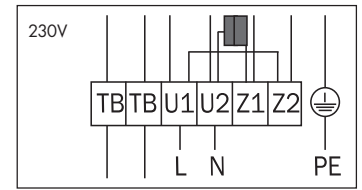

1 ~ Motor with operating capacitor  
U1 brown / U2 blue / Z1 black / Z2 orange

Technical specifications »Fan module« three-phase / alternating current

Type	Module Internal ø mm	Speed revs per min	Current A <sup>1</sup>	Capacity W <sup>2</sup>	Sound power level suction side LwA5 dB(A) <sup>3</sup>	Sound pressure level in 7m distance 45° dB(A) <sup>3</sup>	Air flow m <sup>3</sup> /h Pressure (Pa)						
							0	0	30	30	50	50	80
<b>3-phase current 400V</b>							R	AGROFLEX	R	AGROFLEX	R	AGROFLEX	R
M500-ST-D4-A7	520	1,360	1.10	530	78	53	8,300	9,100	7,800	8,300	7,500	7,600	6,800
M560-ST-D6-A7	580	890	0.74	360	71	46	9,000	10,000	8,000	8,800	7,100	7,600	—
M630-FF-D6-A7	650	930	1.25	540	72	47	12,300	14,200	11,100	12,500	10,200	10,600	—
M710-ST-D6-A7	730	890	1.80	890	81	56	17,000	19,500	15,800	17,600	14,800	16,000	13,100
M800-ST-D6-A7	820	900	2.70	1,350	80	55	22,900	26,000	21,400	23,900	20,300	22,000	18,700
M910-FF-D6-A3	920	880	1.90	920	75	50	23,500	26,100	20,900	23,100	19,100	20,700	15,600
M910-FN-D6-A5	920	880	4.00	1,950	78	53	27,300	31,100	25,500	29,000	24,600	27,400	22,400
M1070-ST-D6-A3	1,090	870	6.20	3,400	93	68	—	48,100	—	45,100	—	43,100	—
M1070-ST-D8-A3	1,090	700	3.60	1,600	87	62	—	39,900	—	35,500	—	32,700	—
M1070-ST-D10-A5	1,090	540	3.20	1,300	82	57	—	34,500	—	30,400	—	27,300	—
M1250-ST-D10-A7	1,270	500	4.50	2,200	83	58	46,100	52,300	41,700	46,200	38,900	42,500	33,100
<b>Alternating current 230V</b>													
M500-ST-W4	520	1,310	2.30	510	76	51	8,000	8,700	7,400	7,900	7,000	7,300	6,500
M560-ST-W6	580	880	1.95	430	74	49	8,900	9,900	8,000	8,600	7,100	7,200	—
M630-FF-W6	650	890	2.50	520	71	46	12,200	13,900	10,700	12,400	9,700	10,500	—
M710-ST-W6	730	850	4.10	890	79	54	16,100	18,500	15,000	16,600	14,000	14,800	12,000
M800-FF-W6	820	830	3.40	760	75	50	18,600	20,900	16,300	18,100	14,700	15,000	11,800
M910-FF-W6	920	940	4.20	940	75	50	22,800	25,300	19,700	22,000	17,500	18,600	13,400

<sup>1</sup> Rated current at the separation point of the fan characteristic curve / <sup>2</sup> Rated power consumption / <sup>3</sup> Measured in full duct without contact protection, version A per ISO 5801 at 30 Pa; R = Framed fan measured in full duct without contact protection, version A per ISO 5801

»AGROFLEX«® duct (3m) with PUR intake nozzle, diffuser and shutter (measured per the above drawing)

FF = owl pinions ST = standard impeller FN = owl sickle impeller W = 230V/50Hz D = 400V/50Hz

### Air capacities

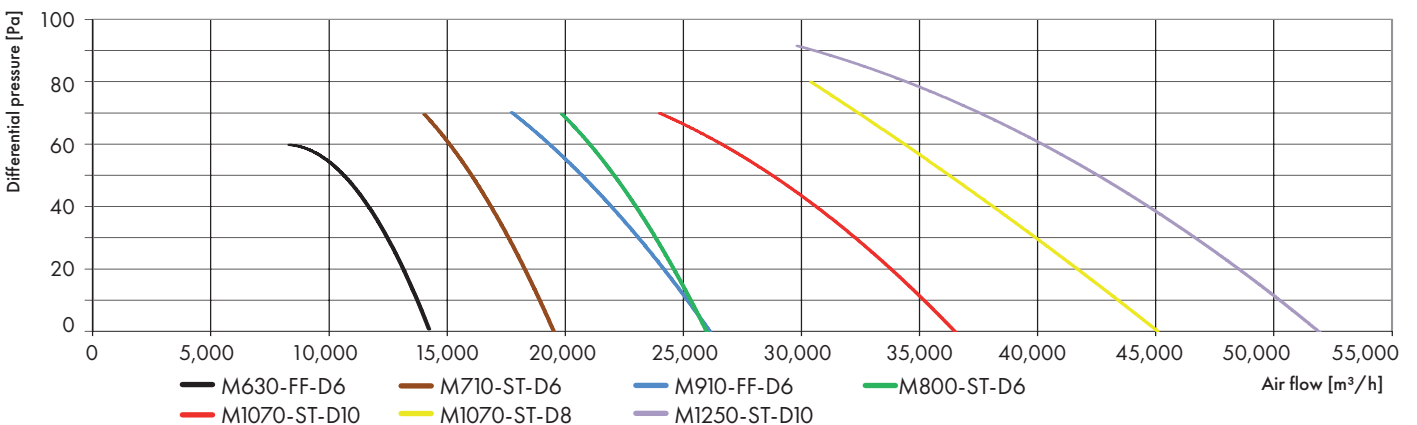

Find your nearest Munters office at [www.munters.com](http://www.munters.com)

Munters reserves the right to make alterations to specifications, quantities, etc., for production or other reasons, subsequent to publication. © Munters AB, 2021