

Munters »ZEW« basic 1600/1600-M

Air inlets

Developed according to the latest technology, the wall inlet »ZEW« basic 1600 offers decisive advantages compared to standard inlets available on the market.

Advantages

- Designed for poultry and swine farming
- The wavy structure of the frame idealizes air flow and throwing range, especially at minimum ventilation
- Flap with drip edge and sealing to avoid icing
- High volume flow thanks to air inlet nozzle
- Integrated slot for optional bird protective grid and air conduction sheet
- Available in standard version or differentiated air flow version
- Made of heat-insulated polyurethane

»ZEW« basic 1600's special wavy shape optimizes the airflow as well as the throwing range with minimum ventilation. Additionally to the wave contour, the air entrance is improved by an integrated air inlet nozzle. This nozzle increases the volume flow and thus contributes to a reduction in energy costs.

Another feature is the special drip edge in combination with a seal at the flap's lower end. This secures that even at temperatures below freezing point the flap does not freeze due to condensate.



»ZEW« basic 1600-M wall air inlet for differentiated air flow

Due to the special position of the flap, it is possible to divert part of the air flow directly downwards. The air is fed directly into the animal area above and below the flap, through the two-part guide. This is particularly advantageous in summer. The flap opening can be infinitely adjusted via the pull rope.

a) closed



b) half open

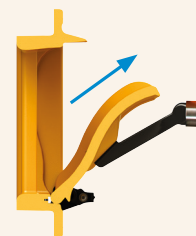

c) open

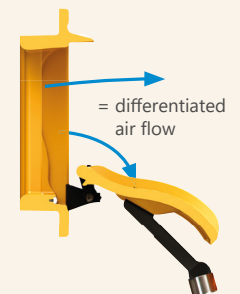

Munters »ZEW« basic 1600/1600-M

Air inlets

Dimensions

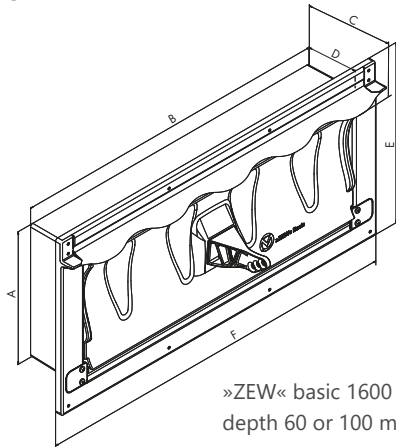

»ZEW« basic 1600 a.c.
depth 60 or 100 mm

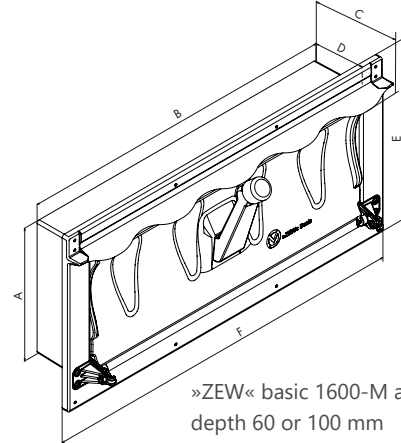

»ZEW« basic 1600-M a.o.
depth 60 or 100 mm

A	B	C	D	E	F
270 mm	650 mm	114/154 mm	60/100 mm	351 mm	731 mm

Technische Daten

		»ZEW« basic 1600		»ZEW« basic 1600-M
		a.o.	a.c.	a.o.
Airflow at 10 Pa	[m ³ /h]	1.600		1.500
Airflow at 20 Pa	[m ³ /h]	2.300		2.200
Airflow at 30 Pa	[m ³ /h]	2.800		2.700
Traction	[N]	15		15
Stroke way	[mm]	420	425	440
Mounting dimension	[W x D/ mm]	650 x 270		650 x 270
Wall opening	[W x D/ mm]	670 x 290		670 x 290

a.o. = automatic opening; a.c. = automatic closing

Verpackungsinformationen

	»ZEW« basic 1600		»ZEW« basic 1600-M	
	60 mm	100 mm	60 mm	100 mm
Quantity	120	84	120	84
Pallet size [W x L x H]	0,78 x 2,3 x ca. 2,25 m	0,78 x 2,3 x ca. 2,25 m	0,78 x 2,3 x ca. 2,25 m	0,78 x 2,3 x ca. 2,25 m

Air capacity

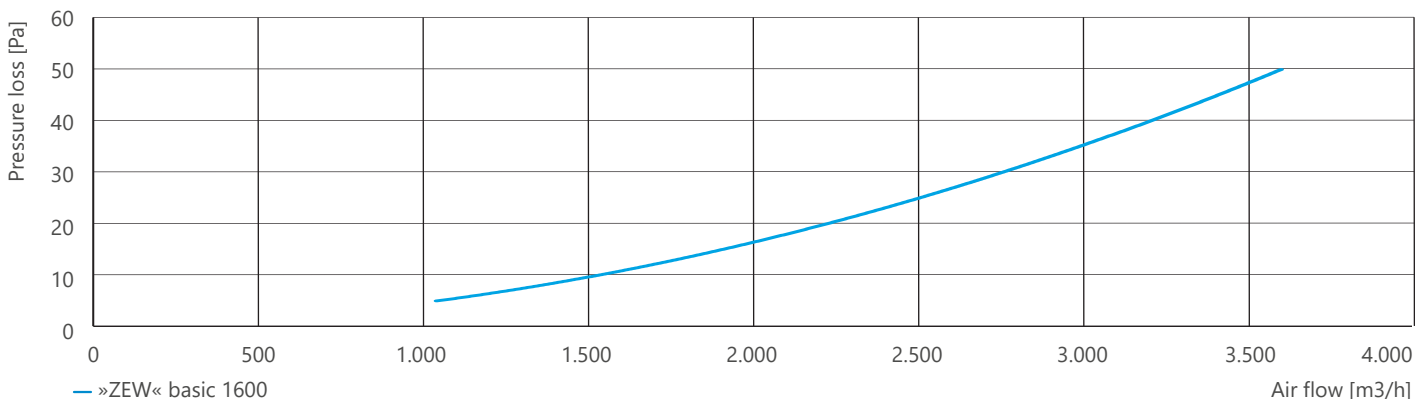

Find your nearest Munters office at www.munters.com

Munters reserves the right to make alterations to specifications, quantities, etc., for production or other reasons, subsequent to publication. © Munters AB, 2024