

Mass Transfer Solutions

Munters mass transfers your
problems into solutions





The evolution of Munters' mass transfer offering

Clean Technologies:

- Meet customer demand in mist elimination, mass transfer and VOC abatement
- Enhance process productivity, lower emissions, and aim for zero environmental impact
- Help create a healthier planet

Since 1955, Munters has provided innovative, state-of-the-art solutions in climate control and mist elimination. Munters also offers a complete range of mass transfer equipment, with solutions to all process industry separation challenges.

Munters added the mass transfer portfolio with the acquisition of KEVIN Enterprises in 2017. KEVIN Enterprises has consistently delivered exceptional mass transfer equipment design and manufacturing to their customers. KEVIN's strong technical capabilities and expertise have been developed as a licensee of Saint Gobain – Nor Pro Corporation (formerly Norton Chemical Corporation) and through their independent experience built over a span of five decades.

Now the mass transfer solutions are part of the new Munters' Clean Technologies segment. Also featuring VOC abatement and mist elimination, Clean Technologies deliver solutions that enhance process productivity, lower emissions, and bring us closer to achieving our zero environmental impact goal.

We serve customers in the traditional processes such as fertilizer, petroleum refinery, oil and gas, petrochemical, fine chemical, pharmaceutical industries, etc throughout the world and many green technologies such as biogas, bio refinery/bio diesel; offering highly customized solutions that solve their most critical separation challenges.

Installation of our cost-effective products improves the performance of our customers' critical distillation, absorption, liquid-liquid extraction, stripping and heat transfer processes.

Products

Munters offer a broad range of mass transfer products to help you attain a high-performance system. A tower that contains well matched components that optimize fractionation, absorption, stripping and extraction performance.

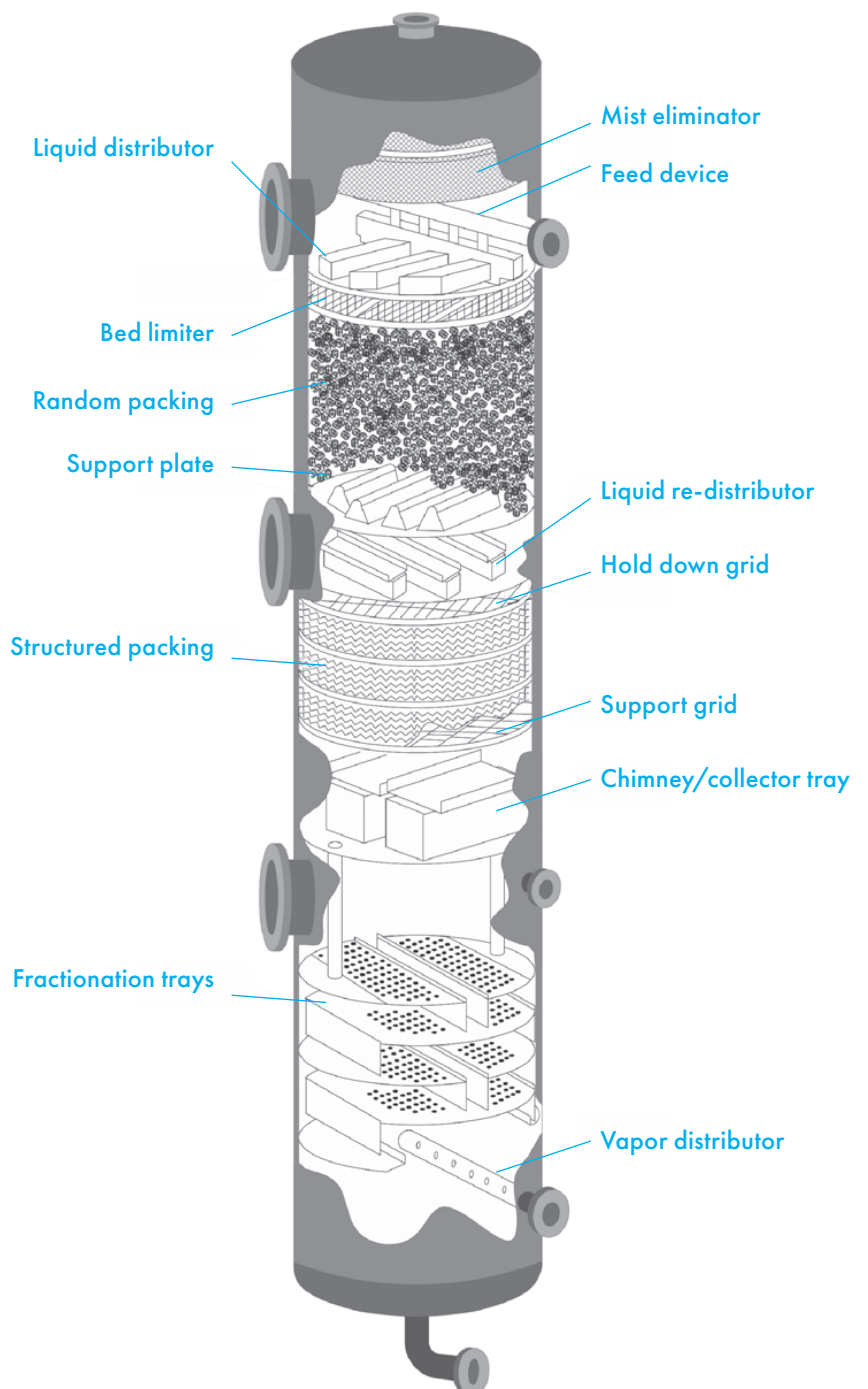



Tower trays

Trays are used where pressure drop limitations are not critical such as high-pressure distillation operations. However, there are a few atmospheric, moderate pressure and vacuum operations where tower trays are used.

Munters offers sieve trays, valve trays, baffle trays, bubble cap trays and high-capacity trays. They are also available in segmental, or cartridge type construction based on diameters to suit customer requirements.

- Valve tray
- Sieve tray
- High-capacity tray
- Bubble cap tray
- Baffle tray
- Hardwares and fasteners
- Custom tray design

Types of tray valves

With technical expertise acquired over decades, Munters offers wide range of floating and fixed valves. Incorporating suitable combination of valves, Munters make sure that these trays serve you well.

Munters also provides tray valve customizations :

- Directional valves: direct liquid towards downcomer, avoiding eddy formation at periphery
- Anti-spin valves: prevent dislodging of valves during operation
- Venturi deck: reduced pressure drop at liquid entrance and reversal areas

Floating valves:

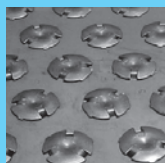

KFV series

- Circular floating valves
- Available with sharp and venturi orifice



KCV3 valves

- Circular disc moving inside cage
- Lower pressure drop



KFRV series

- Rectangular floating valves available in different sizes
- Minimal weeping due to parallel orientation of valves to liquid flow

Fixed valves:

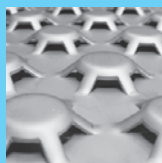

KRVH valves

- Circular, fixed on tray deck
- High-capacity handling and lower pressure drop per theoretical stage



KHV® series

- Rectangular shape, available in different sizes
- High-capacity valves



KEP® series

- Tapered design for better vapor liquid contact
- Flexibility of operation within wide range
- Optimum performance in fouling service

Valve tray

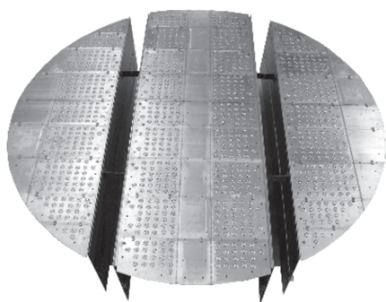

As the name suggests, valve trays are provided with valves to cover tray perforations. Valves are either moveable (conventional) or fixed. They provide extra resistance to rising vapors, which get discharged laterally. This helps provide better contact with the liquid on the tray and increases efficiency. Valve trays have better turn-down.

The valves are either round or rectangular. Floating valves move vertically to create variable lateral openings for vapors to bubble through the liquid pool. An increase in vapor energy moves the valve upwards and the valves sit on the deck when vapor energy is very low. Cage valves are part of the cage structure and a lighter movable disk that sits on the perforation. The disk provides slower pressure drop as it gives less resistance to the rising vapors. The valve trays are also available with venturi deck.



High-capacity tray

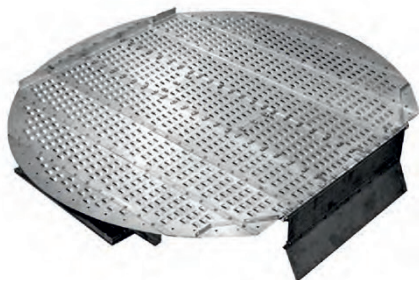

Munters also provides high-capacity trays with additional features on the trays that aide column capacity. Munters has successfully replaced conventional trays with high-capacity trays in quite a few instances. One of the aspects to achieve high capacity is using fixed valves instead of floating. The fixed valve tray is a valve tray whose valve units are fixed in the fully open position. Because of their ability in handling high capacity, they don't handle a wide turn-down ratio but are relatively better than sieve trays. The absence of the moving disk eliminates wear and sticking. The valves can be circular, flat-dome shaped, triangular or rectangular.

Sieve tray

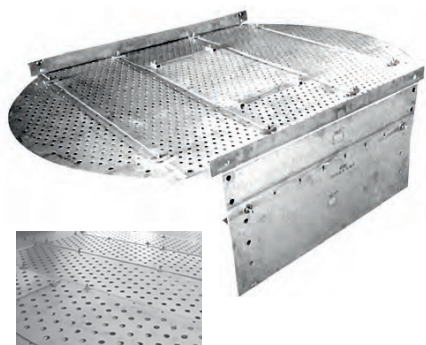

The sieve tray is a flat perforated plate with no moving parts or covers. Vapor rises from the holes/perforations to the tray above, mixing cross-current with the liquid flow. The vapor energy keeps the liquid from flowing down through the holes. The latter moves across the tray and travels to the tray below through the down-comer. Sieve trays have better capacity and moderate efficiency than valve and bubble cap trays but have limited operating range flexibility. The sieve size typically ranges from 0.5 to 2.5 cm. Smaller sieves reduce weeping while larger sieves are used in fouling services.

The major advantages of sieve trays are low maintenance costs and low fouling tendency when compared to other conventional trays. Also, sieve trays are simple and easy to fabricate when compared to other mass transfer trays.

Bubble cap tray



Bubble cap trays feature a flat perforated plate with risers (like pipes) around the perforations and caps in the form of inverted cups over the risers. The caps are usually equipped with slots or holes, where vapor comes out. The cap is mounted so there is a space between the riser and cap to let vapor pass. These are the oldest form of mass transfer trays. Vapor rises through the riser and is directed downward by the cap where it passes through slots in the cap, finally bubbling through the liquid on the tray. As vapor must pass through many passages this leads to higher pressure drop and lower capacity than other conventional trays, but with higher efficiency. Liquid and froth are filled on the tray to a depth at least equal to the weir height or riser height, giving the bubble-cap tray a unique ability to be used for reaction applications.



Baffle tray



Baffle trays are the simplest type of trays where liquid and vapor travel through the same passage. They have excellent capacity, however very low efficiency. There are numerous types of baffle trays, namely dual flow, shower deck, side to side pan, disc, and donut, etc. These trays operate with liquid continuously weeping through the holes. Due to the absence of downcomers, they offer more area and therefore greater capacity. Hence, they are useful in revamps if some efficiency can be sacrificed.

Hardware and fasteners

No installation is complete without use of effective hardware and fasteners on equipment. Munters provides a wide range of hardware and fasteners available to suit all requirements.

Our Universal Vantage® Lock eliminates the needs for bolts and speeds up the installation process. Vantage hook clamp eliminates the need for traditional rods for fixing of mist eliminators. Vantage Universal clamp can be used with any support ring irrespective its thickness.



Custom tray design



Cartridge tray

These are used when column diameter is small, and it's impossible for a person to enter inside the column. Cartridge trays are a bundle of multiple trays and downcomers held together on a rod assembly. Each bundle is typically 3 to 3.5 meters long consisting of 10–15 trays. Cartridge sieve, valve or bubble cap are available.



ERD trays

For towers which are prone to upsets, it's recommended that trays should be designed for heavy-duty uplift resistance. This is achieved by providing Explosion-Hatch Resistance Doors (ERD) on the trays. The door design is based on the opening force provided (amount of protection) calculated in terms of pressure. An explosion-proof door arrangement prevents upsets due to sudden upthrust from the rising vapor, maintaining optimum functionality of trays. When frequent upsets are expected, the upgraded design reduces the risk of equipment damage (panel dislodgement) which can lead to significant losses in production.

Reverse flow tray

These types of trays are mainly suitable for low liquid flowrate operations. There is a central baffle in place and liquid is forced to flow around that baffle to the inlet and outlet i.e., downcomer pouring the liquid to the below tray and downcomer carrying the liquid from above tray are on the same side of the tray. The advantage is longer liquid flow path length and increased vapor liquid contact, which is especially useful when there is less liquid flowrate.

Reverse flow bubble cap trays are most used since bubble caps are the preferred choice for lesser liquid flowrate operations, however reverse flow valve trays or sieve trays can also be designed to requirement.

We are also approved sub-contractors for manufacturing and supply of:

- M/s. UOP, UK for their proprietary MD™ trays.
- M/s. Stone & Webster now TechnipFMC, USA for their proprietary Ripple™ trays.
- M/s. Aker Kvaerner Process Systems Ltd. for their proprietary base trays.
- M/s. Engineers India Ltd. (EIL) for mass transfer equipment.



Random packings

While packed towers have been in existence for over a century, many improvements have been developed to maximize column performance. To derive enhanced yields from a packed tower, one must select and install matched components to optimize distillation, absorption, or stripping performance.

- Pall ring
- Tall-Pak®
- Tierce ring
- Medal-Pak®
- Omni-Pak®
- Saddles

Pall ring

Pall rings are traditional ring type random packing with global installed base and a well-documented performance history. They are available in metal and plastic.



Item/Size	Surface area m ² m ³ (ft ² /ft ³)	Voidage (%)
Pall ring 10 mm (3/8")	482 (147.0)	92.8
Pall ring 16 mm (5/8")	344 (104.9)	93.1
Pall ring 25 mm (1")	206 (62.8)	94.8
Pall ring 38 mm (1.5")	130 (39.7)	96.0
Pall ring 50 mm (2")	102 (31.1)	95.9

Tall-Pak®

Tall-Pak® (formerly sold as Hy-Pak®) is an excellent substitute for traditional pall rings and is one of the most efficient ring-type random packings. At almost the same efficiency, it provides lower pressure drop than a pall ring. It also increases the interfacial area available for gas-liquid contact. Its unique design incorporates strength reinforcing ribs that offer lower thickness and taller beds, thus reducing procurement costs when compared to traditional pall rings.



Item/Size	Surface area m ² m ³ (ft ² /ft ³)	Voidage (%)
Tall-Pak® # 1 (30 mm)	171 (52.2)	96.5
Tall-Pak® # 1.5 (45 mm)	118 (36.0)	97.0
Tall-Pak® # 2 (60 mm)	84 (25.6)	97.8
Tall-Pak® # 3 (90 mm)	57 (17.4)	98.0



Tierce ring



Tierce rings are also ring type random packings but with an approximate diameter to height aspect ratio of 3:1 and are further flared along the periphery for strengthening of packing.

Item/Size	Surface area m ² m ³ (ft ² /ft ³)	Voidage (%)
Tierce ring # 1	250 (76.2)	96
Tierce ring # 1.5	190 (57.9)	96
Tierce ring # 2	150 (45.7)	97
Tierce ring # 2.5	125 (38.2)	97
Tierce ring # 3	102 (31.1)	98

Medal-Pak®



Medal-Pak® (formerly sold as IMTP®) offers the best of both the worlds in terms of performance (i.e., low-pressure drop and high efficiency). It can be effectively used in both high pressure and vacuum towers. Other advantages include large effective interfacial area, high mechanical strength, and low cost. It overcomes the problem of “opening out” at the ends as can be monolithic construction experienced with ring shaped packings.

Medal-Pak® is available in an array of sizes to provide multiple combinations of efficiency and pressure drop. Medal-Pak® can be fabricated from a variety of metals including, but not limited to, carbon steel, stainless steel, copper, aluminum, titanium, zirconium, etc.

Item/Size	Surface area m ² m ³ (ft ² /ft ³)	Voidage (%)
Medal-Pak® # 15	291 (88.8)	95.6
Medal-Pak® # 25	225 (68.6)	96.6
Medal-Pak® # 40	150 (45.7)	97.7
Medal-Pak® # 50	100 (30.5)	98.0
Medal-Pak® # 60	74 (22.6)	98.0
Medal-Pak® # 70	60 (18.3)	98.5

Omni-Pak®

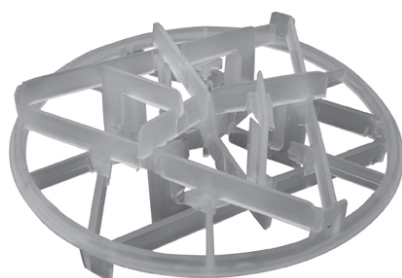

Omni-Pak® (formerly sold as Snowflake®) is a high-performance plastic packing. It offers superior efficiency and capacity in environmental application such as scrubbing and stripping. Its distinctive shape lowers the pressure drop, which significantly reduces electrical energy consumption. Its various applications include fume scrubbing, acid gas absorption, VOC stripping, wastewater treatment, flue gas scrubbing, etc. It provides higher efficiency compared to pall rings 38 mm (1.5”) and plastic super saddles and larger.

Item/Size	Surface area m ² m ³ (ft ² /ft ³)	Voidage (%)
Omni-Pak®	100 (30.5)	95

Saddles

Plastic super saddles (PSS) are the improvised version of the original saddles. They are designed to give enhanced internal gas and liquid distribution. The unique scalloped edge is the key to the product's high performance in terms of high capacity and improved mass transfer rate, when compared to traditional plastic saddles. It also overcomes the problem of nesting that is commonly encountered with ordinary saddles. Saddles are also available in ceramic material. They feature a glazed construction to enhance capacity and reduce porosity. Saddles are typically used in processes requiring high temperature and chemical attack resistance.



Item/Size	Surface area m ² m ³ (ft ² /ft ³)	Voidage (%)
Plastic super saddles # 1	199 (60.7)	90.0
Plastic super saddles # 2	105 (32.0)	93.3
Plastic super saddles # 3	89 (27.1)	94.0

Item/Size	Surface area m ² m ³ (ft ² /ft ³)	Voidage (%)
Ceramic saddles 1"	255 (77.7)	73.0
Ceramic saddles 1.5"	176 (53.6)	74.0
Ceramic saddles 2"	120 (36.6)	75.0

Note: The above packing are also available in custom sizes from 6 mm to 75 mm.

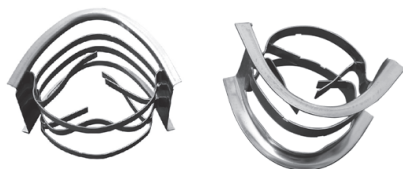

Metallic random packing range:

AISI 304/L, AISI 316/L, AISI 430, AISI 410/S, hestalloxy, copper, aluminium, duplex, inconel and other metallic grades.

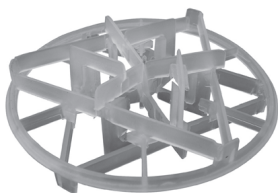

Non-metallic random packing range:

PP (various grades), HDPE, PVC, ceramic, carbon, and other non-metallic materials.

Engineering companies we associate with

- Air Liquide
- Air Products
- Aker Solutions
- Amec Foster Wheeler
- BHEL
- Black & Veatch
- Chemtex
- CTCI
- Descon Engineering
- Engineers India Ltd.
- Fluor Daneil
- GASCO
- GE
- Haldor-Topsoe
- IBI Chematur
- KBR
- L&T
- Linde
- MHI
- Mott MacDonald
- Petrofac
- Refinex
- Saipem/Snamprogetti
- Samsung
- SNC Lavalin
- TCE
- Technicas Reunidas
- TechnipFMC
- Tecnimont
- Thyssenkrupp/UHDE
- Toyo Engineering
- Worley Parsons
- Zeeco



Structured packings

Structured packings are constructed from corrugated and textured metal sheets. The angle of inclination of the corrugations of adjacent sheets is reversed with respect to the vertical column axis, forming mixing cells at every point where the corrugations intersect.

This set-up ensures an excellent, uniform wetting under low and high liquid loads. Column operation at low liquid loads requires specially designed distributors to ensure adequate surface wetting.

- ME-II® series
- Vantage® series
- Vantage® Additional® series (high capacity)
- ME-II® Wire Mesh series
- Grid packing series

Packings

Each layer of structured packing is rotated 90° so that the sheets of one layer are perpendicular to the sheets of the layer above and below. While passing through each layer, gas and liquid are thoroughly mixed in the direction parallel to the plane of the sheets. By rotating subsequent layers, excellent mixing and spreading, both side-to-side and front-to-back, of fluids are obtained over the entire cross-section of the tower. Perforations and surface texturing maximize liquid spread. These characteristics tend to show significant performance benefits in low pressure and low irrigation rate application..

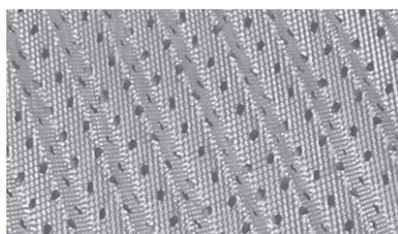
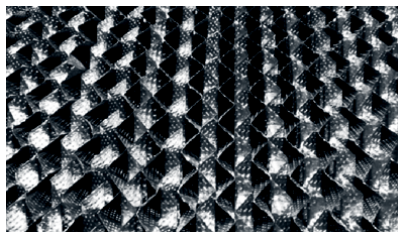

Structured packings are available in two different inclination angles, i.e., type "X" and type "Y". "Y" packings have an inclination angle of about 45° from the horizontal axis, and are the most widely used. They provide higher efficiency over their corresponding "X" counterpart, but at the cost of a higher pressure drop/lower capacity. "X" packings have an inclination angle of 60° from horizontal axis and are used in high capacity and low pressure drop applications.

High throughput (type "X")

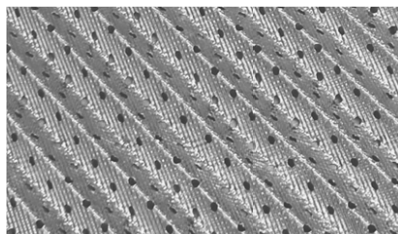

Standard (type "Y")



ME-II® series

ME-II® structured packing, is an efficient and economical structured packing that is widely used in the industry today. ME-II® structured packing has all the desirable characteristics like predictable throughput, low pressure drop, good efficiency and flexibility; which plays a vital role in separations. ME-II® structured packing is available in an array of surface areas (corrugation crimp sizes) and we can also provide inter mediate sizes to suit a particular case.

Packing type	Specific surface area (m ² /m ³)
ME-II® 65 X	65
ME-II® 125 X	125
ME-II® 170 X	170
ME-II® 200 X	210
ME-II® 250 X	250
ME-II® 350 X	350
ME-II® 500 X	500
ME-II® 750 X	750

Packing type	Specific surface area (m ² /m ³)
ME-II® 65 Y	65
ME-II® 125 Y	125
ME-II® 170 Y	170
ME-II® 200 Y	210
ME-II® 250 Y	250
ME-II® 350 Y	350
ME-II® 500 Y	500
ME-II® 750 Y	750

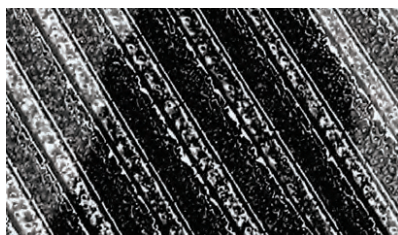

Vantage® texture

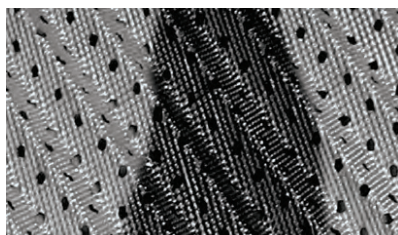

Competitor's texture

Vantage® series

We also offer the Vantage series structured packing, which exceeds the performance of almost all other standard structured packing due to its exceptional liquid spreading characteristic. Vantage series structured packing sheets have innumerable fine perforations (pierced but not punched holes) throughout the surface. This is a distinct advantage over other structured packings that have punched holes resulting in loss of valuable surface area that reduces the potential efficiency of the product. It is available in same sizes as regular ME-II structured packing.

Vantage® series structured packing has the added advantage of surface treatment, which is expected to enhance performance.

Vantage series structured packings are also available in two inclination angles, "X" and "Y".

Vantage® Additional® series (high capacity)

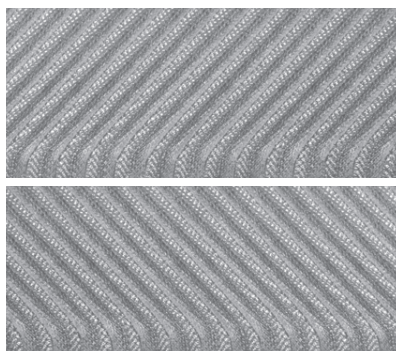

Our high-capacity structured packing belonging to the Vantage® series, has a unique texture to provide an excellent liquid spread and thus lateral distribution. Due to its fluid-dynamic curved shape, our Vantage® Additional® structured packing smoothens the gas passage and minimizes localized hold-up. It reduces premature flooding at the inter-layer transfer zone. This salient feature provides significant margin at higher loads compared to the traditional product. The Vantage series is available in the following sizes:

Vantage® 200 Additional®	Vantage® 450 Additional®
Vantage® 250 Additional®	Vantage® 750 Additional®
Vantage® 350 Additional®	Vantage® WM BX Additional®

We can also provide intermediate sizes to suit a particular application.

ME-II® Wire Mesh series



ME-II® Wire Mesh packing has enhanced self-wetting characteristics as the fiber is woven from fine diameter wires. The packing element consists of parallel-perforated corrugated sheets of wire mesh.

These packings are particularly suited in separations that require many separation stages, which typically operate under high vacuum and therefore low liquid loads. The capillary action of the wire mesh ensures complete surface wetting and provides a low HETP. Typically, 5 to 10 theoretical stages per meter of packed height can be achieved with this packing when complemented with high efficiency internals.

Characteristics:

High separation efficiency almost up to capacity limits

- High throughput
- Low pressure drop
- Liquid loads as low as approximately 0.1 m³/m².hr
- Can be adapted to any fractionating task by variable specific surface.

ME-II® Wire Mesh packing is available in following two types

Packing type	Specific surface area (m ² /m ³)
ME-II® Wire Mesh BX	500
ME-II® Wire Mesh CY	750

Grid packing series

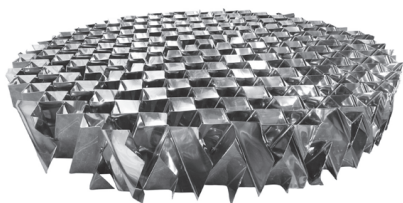

Grid packing are recommended for applications with fouling, coking and solid contents.

The grid packing has robust mechanical structure, fabricated in modules for ease of installation and cleaning.

The grid packing offers minimum pressure drop and higher capacity.

Packing type	Specific surface area (m ² /m ³)
K-grid 40Y	40
K-grid 64X	64
K-grid 64Y	64
K-grid 90X	90

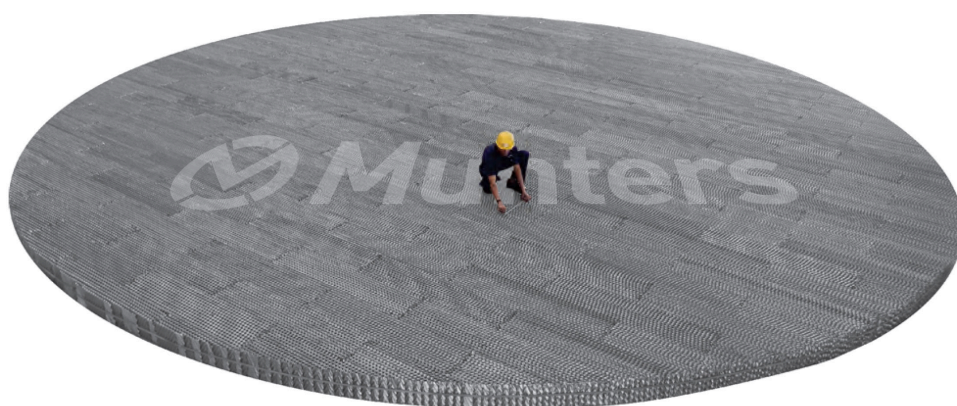



Liquid distributors

Packed tower design is based on the fundamental concept of equal liquid and gas superficial velocity across the column section. It is important to manage and ensure very uniform liquid distribution at the top of the bed.

Distributors are internals installed above a packed bed, which provide finite liquid distribution over the packed bed. A distributor allows liquid to be distributed over the packed bed in discrete streams and provides a separate passage for upward flowing gas.

- Pan type distributor/redistributor
- Deck type distributor/redistributor
- Trough type distributor with parting box
- Trough type distributor/redistributor with sump
- Distributor/redistributor with enclosure
- Distributor/redistributor with flow multiplier
- Distributor/redistributor with V-Weir
- Spray nozzle distributor
- Pipe arm distributor

Tower internals

Packed tower design is based on the fundamental concept of equal liquid and gas superficial velocity across the column section. The pressure drop across the packing provides an impetus for the upward flowing gas to become uniformly distributed across the column area. The liquid flows down the packed bed via gravity and unlike gas, liquid has poorer cross-mixing tendencies. It is therefore imperative to manage and ensure very uniform liquid distribution at the top of the bed. Distributors are internals installed above a packed bed, which perform the job of providing finite liquid distribution over the packed bed. A distributor allows liquid to be distributed over the packed bed in discrete streams and provides a separate passage for the upward flowing gas.

Once liquid travels certain bed height it starts losing the initial distribution tendency. Hence liquid redistributors are provided to collect all the down flowing liquid and redirect it uniformly into the next packed bed.

A packed bed irrigated by a good distributor allows one to realize full separation potential (number of stages) of the packed bed.

Distribution quality

Quantifying the uniformity of liquid distribution is done by calculating the distribution quality (DQ) of a distributor. It relates the liquid flux across the column area at the top of the packed bed by marking circles proportional to the liquid flow through a particular orifice and then considering the irrigated, overlapping, and un-irrigated areas of the circles. An ideal distributor should have a DQ of 100%, but practical considerations restrict the DQ to about 95% maximum. A low DQ indicates a high degree of maldistribution, and some portions of the column cross sectional area may receive substantially different volumes of liquid when compared to other portions of cross-sectional area. In large diameter columns, proper irrigation of areas near the column wall becomes a very crucial factor in maintaining a good DQ.

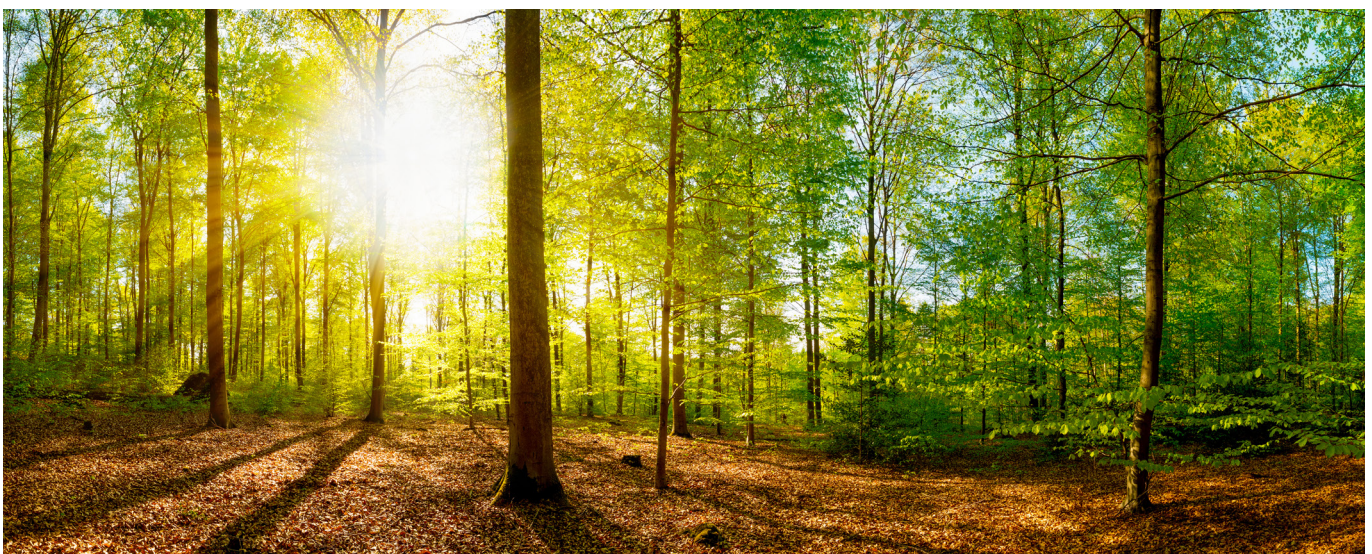

A distributor with a very good DQ (85–95%) helps to exploit the full separation efficiency of a packed bed. As the DQ decreases the number of stages that can be realized from the packed bed decreases, thus decreasing the separation efficiency. Various factors to consider in the design of liquid distributors/redistributors are:

1. Point count

This indicates the number of irrigation points provided per square meter (foot) of the column area and is primarily a function of packing size, the liquid load, and the desired DQ. Smaller, highly efficient packings (that provide a very low HETP), require a larger number of drip points and vice-versa.

2. Hydraulic design

This is the most important aspect of the distributor design wherein the designer determines the various dimensional details of the distributor to ensure its efficiency over the desired range of working conditions.

A distributor can feed the liquid to the packing top either under pressure, as in a pressure feed distributor, or by gravity, as in a gravity flow distributor, where the liquid falls through the distributor by virtue of the liquid head on the distributor deck. Pressure feed distributors can be categorized as either ladder arm or of spray nozzle distributors. These distributors are used for very specific applications, such as heat transfer services. Because these distributors operate under pressure, the orifice sizes in these distributors are usually small. Pressure feed distributors should not be used with flashing feed. The major advantage of using a pressure feed distributor is the total wetting of the surface of the packed bed. High point to point flow variation and high cost are some of the disadvantages to these types of distributors.

Unless otherwise requested we always recommend a gravity flow distributor. These distributors offer excellent uniformity and control of liquid flow to the packed bed. A gravity feed distributor can utilize either orifices or V-Weirs to feed the liquid. The orifices can be located on the floor of the deck/trough or on the side wall of a trough (single level or multilevel). Passage for gas rising upwards is either provided by riser boxes/pipes or through the gaps between the troughs.

Orifices are sized to maintain a minimum liquid head at desired turn down conditions and to avoid distributor flooding/overflow during turn up conditions (maximum desired flow rates). Very small orifice diameters are avoided to prevent fouling. Distributor levelness, liquid gradient due to cross flow, aeration of the liquid from falling liquid streams, and the ledge/support ring levelness are considered during the orifice sizing, so that even at very low flows, the orifice-to-orifice flow variation is maintained in acceptable limits.

For highly fouling services, which can occur in processes with a high level of sediments in the feed stream, coking, debris, polymerization, etc., orifices on the deck floor are avoided. Depending on the service, V-weirs or orifices on the side wall are recommended.

Multilevel orifices help distributor operation over a wide range of flows and are typically used whenever a very high turn-up/turn down range is required.

3. Distribution quality (DQ)

The drip points are laid out to meet specified drip point requirements. Design considerations for distribution quality include the service and separation efficiency required from the packed bed and packing size. During this stage of the distributor design, allowances are made for the distributor construction details such as support beams, gas risers, etc., to obtain the required DQ for a particular distributor.

Major factors guiding selection of distributor model:

- Tower size and mechanical constraints
- Type of service
- Turn down ratio/operating range
- Type and size of packing
- Vapor/gas pressure drop requirements
- Riser layout to control the liquid cross flow velocity across the deck and vapor distribution across the distributor.
- Available method of attaching the distributor to the column.



Pan type distributor/redistributor (model DPC501/RPC502)

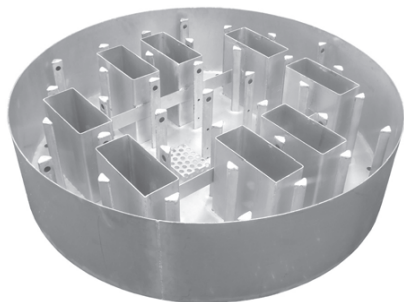

This model is used for small towers. It is a high-performance distributor consisting of meticulously sized orifices, uniformly laid out on the base of the pan for proper liquid down flow, and adequate open area for upward flow of vapor either in the form of risers and/or annular space between column wall and pan. This distributor can be made in both single and multi-piece construction. In multi-piece construction, all joints are gasketed.

Attachment to the tower wall is usually achieved by bolting to tower attachment clips. It can also be sandwiched between body flanges. Alternatively, it can be suspended from a ring, sandwiched between the body flanges. Mounting methods for the distributor will depend upon the location of other internals and in case of revamps, the type of attachments already present in the column.

A redistributor employs riser caps and when the attachment is to clips, a wall wiper is also required.

Selection criteria*:

- Column diameter between 150–900 mm (6–36 inches)
- Maximum turndown ratio 2:1
- Liquid rates $> 5 \text{ m}^3/\text{m}^2.\text{hr}$ (2.0 GPM/ft²)
- Low fouling

Riser deck distributor/redistributor (model DRD503/RRD504)

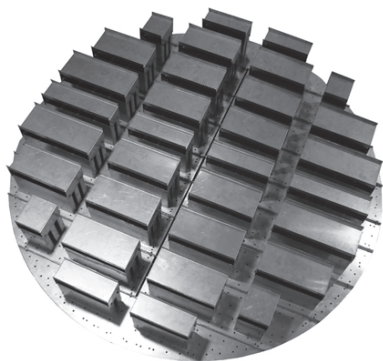

The riser deck distributor is a deck type distributor where orifices are located on the base/deck. Gas risers located between the orifices propagate liquid crossflow, thereby enhancing distribution quality.

This type of distributor is generally supplied in multi-piece construction and all joints are sealed with gaskets. Attached by clamping to a ledge/support ring that is welded to a column wall. This distributor can be provided with anti-migration bars in the risers to eliminate the requirement for a bed limiter. Redistributor risers are capped to prevent bypassing of liquid through risers from liquid raining down from the packed bed above.

Selection criteria*:

- Column diameter $> 600 \text{ mm}$ (24 inches)
- Maximum turndown ratio 2:1
- Liquid rates $> 5 \text{ m}^3/\text{m}^2.\text{hr}$ (2.0 GPM/ft²)
- Low fouling

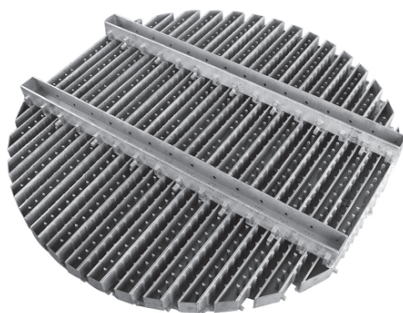

Trough type distributor with parting box (model DTP505)

The trough type distributor consists of long tunnels called troughs, and one or more parting boxes, which feed liquid to the troughs. The parting box helps control feed velocity to the troughs and ensures proportional distribution of the liquid. The space between the troughs is available for vapor passage. Number and location of the parting boxes depends on the column diameter. Orifices can be located either on the wall or on the base of the troughs. When orifices are located on the wall, conductor tubes are provided at the wall to guide the flow of liquid.

The trough style distributor usually rests on a ledge/support ring. It can also be suspended from beams. The advantage of parting box is the absence of joints, thus providing excellent liquid seal. Redistributors are not available in this model.

Selection criteria*:

- Column diameter > 250 mm (10 inches)
- Maximum turndown ratio 10:1
- Liquid rates between 2–30 m³/m².hr (0.5–12.25 GPM/ft²)
- Low to medium fouling

Trough type distributor/redistributor with sump (model DTS506/RTS507)

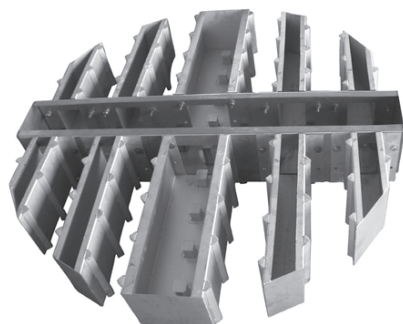

This distributor is like model DTP505 except for the parting box, which is replaced by a sump. Feed enters the sump, which divides it proportionately to the troughs. Orifice for liquid can be located either on the base or on the wall of the troughs. Distribution points are also located at the centerline of the distributor by providing tubes in the center of the sump.

Achieving adequate sealing is critical because of the large number of joints at the sump to trough connection. All joints are gasketed for adequate sealing.

This distributor rests on a ledge/support ring. The redistributor includes riser caps and a wall wiper.

Selection criteria*:

- Column diameter > 250 mm (10 inches)
- Maximum turndown ratio 10:1
- Liquid rates between 2–30 m³/m².hr (0.5–12.25 GPM/ft²)
- Low to medium fouling

Trough type distributor/redistributor with end closure (model DTE508/RTE509)

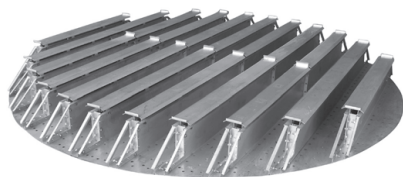

This type of distributor consists of long risers that are made from the deck itself, giving it a trough type look with end closure plates for liquid balancing between the troughs. The orifices are laid either in square pitch or triangular pitch on the deck. This distributor is clamped to a ledge/support ring.

Selection criteria*:

- Column diameter > 300 mm (12 inches)
- Low fouling tendency
- Liquid rates between 2.0–120 m³/m².hr (0.8–50 GPM/ft²)
- Maximum turndown ratio 2.5:1

Flow multiplier distributor/redistributor (model DFM510/RFM511)



This type of Distributor is primarily used in very low liquid flow. Flow multipliers are used below each orifice to increase the drip point density. Construction is like the riser deck distributor/trough type distributor except that the orifices are located on the wall of the tubes instead of the deck. Tubes are welded to and extend below the deck. At the end of the tubes, liquid is divided into three or more streams by means of flow point multipliers. This distributor is clamped on a ledge/support ring.

Selection criteria*:

- Column diameter > 250 mm (10 inches)
- Maximum turndown ratio 3:1
- Liquid rates between < 30 m³/m².hr (12.25 GPM/ft²)
- Medium fouling

V-Weir distributor (model DVW512/RVW 515)

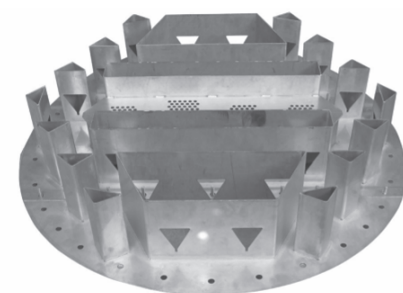

V-Weir distributors are used when the fouling tendency of the system is high. A wide turn down range is possible due to the weirs, which permit greater flow rates as liquid head increases. With this type of distributor, the liquid and gas share the same flow area. The gas velocity through the risers usually limits the maximum flow rate of this style distributor. These distributors provide low distribution quality compared to other distributors.

V-Weir distributors are made either in pan construction (for small columns) or deck/trough construction (for larger columns). This style distributor is clamped to or is rested on a ledge/support ring.

Selection criteria*:

- Column diameter > 250 mm (10 inches)
- Maximum turndown ratio 20:1
- Liquid rates between 2.5–100 m³/m².hr (1–40 GPM/ft²)
- High fouling

Spray nozzle distributor (model DSN513)

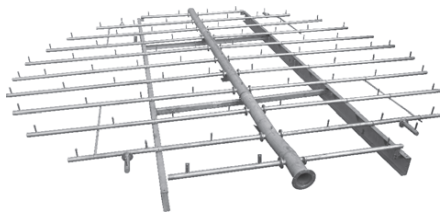

As the name indicates, this type of distributor consists of spray nozzles arranged on pipe assembly. It is generally used for shallow beds in heat transfer applications, in scrubbing services, and applications where a large vapor handling capacity is most important. It can also handle low liquid flow rates.

The quality of distribution is somewhat inferior compared to orifice type distributors because the spray cones create areas of uneven irrigation, and a significant amount of liquid is directed towards the tower wall. The main header is flanged at one end and clamped to a column wall clip at the opposite end. Depending on the column diameter, the individual laterals may also be clamped to column wall clips.

Selection criteria*:

- Column diameter > 250 mm (10 inches)
- Maximum turndown ratio 3:1
- Liquid rates between 0.5–120 m³/m².hr (0.2–50 GPM/ft²)
- Clean service

Pipe arm distributor (model DPA514)

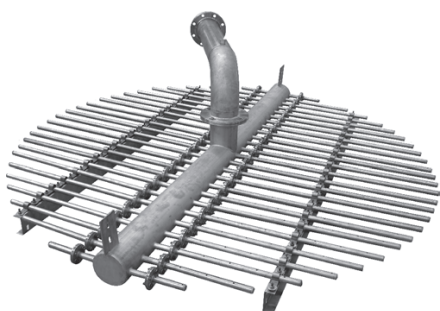

This is a very simple distributor consisting of a header and lateral assembly. It requires very little column height and provides high open area resulting in very low pressure drop. It does not provide very high distribution quality, and thus, finds limited applications. The main header is flanged at one end and clamped to a column wall clip at the opposite end.

Selection criteria*:

- Column diameter > 250 mm (10 inches)
- Maximum turndown ratio 3:1
- Liquid rates: 4.0–25 m³/m².hr (1.0–10.25 GPM/ft²)
- Clean service

* General note on selection criteria:

Selection criteria guidelines given here are typical but not limiting. Under certain conditions special design provisions can be made for accommodating varied hydraulic and mechanical requirements.

These are custom made equipment. Photos given are for representation purpose only.



Vapor distributors

There are various types of gas distributors that help attain optimum mass transfer in the packed bed, distribution of liquid and gas are equally important.

The significant role of liquid distribution is generally well understood, while the importance of vapor/gas distribution requires more emphasis

Vapor-only feed devices are mainly required for reboiler returns. If the column offers adequate pressure drop, the packings themselves tend to mix the vapors. In the event of very low pressure drop across the packed beds, vapor channelling can become a serious problem. The kinetic energy of the vapor and its composition at the point of introduction are the two main factors considered in designing the vapor entry device.

- Vapor feed distributor
- Vapor distributor plate
- Vapor inlet device

Vapor feed distributor (model VFD546)

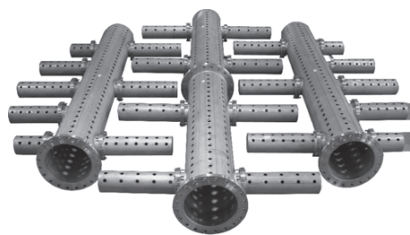

This is a pipe arm vapor distributor, used when a vapor feed is required to reach uniformly throughout the entire cross section of the column and mix well with vapor already present in the column. Typical applications include introduction of a vapor feed into the column or introduction of vapor into the bottom of larger diameter columns. This distributor would be supported using an internal pipe flange and/or wall clips.

Vapor distributor plate (model VDP547)

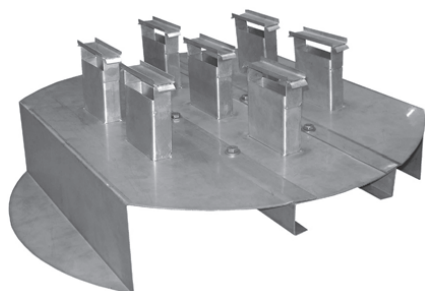

This is a vapor distributor plate, used when vapor enters the bottom of a column with very high kinetic energy. This distributor will break the velocity of vapor and bring down its kinetic energy and ensure good distribution across the packed bed. This model can be manufactured in any weldable sheet-metal. It is gasketed and is supported by a ledge/support ring. Mid-span support beams may be required in large columns. This distributor is supplied with liquid downpipes or a sump for removal of the liquid.

Vapor inlet device (model VID808)



This model is extensively used whenever a very high-velocity vapor flow is anticipated. The construction breaks the momentum of vapor feed and then evenly distributes it across the cross section. This is achieved by dividing the feed mixture into a horizontal stream that reduces the vertical vapor velocity within a shorter distance from its discharge into the tower. Typically, it is in the bottom section of the column where re-boiler feed is entering in the tower or between the tray and packing section. Kinetic energy of the inlet vapor and the vapor fraction are the two factors considered while designing.





Feed devices

Processes demand various feeds to be introduced into the column at appropriate locations. The feeds being introduced could be:

- Liquid-only
- Liquid and vapor above a packed bed (flashing or suppressed flash) or between the trays
- Vapor only below a packed bed
- Reboiler returns

Liquid-only feed devices are required to introduce liquid into the column, either as feed or as reflux. The liquid is fed into/onto the distributor and its design depends on the distributor type, liquid flow, operation range, degree of sub-cooling, etc.

For liquid and vapor feed devices above a distributor, separating the two phases is of primary importance. The primary design factors are the feed flow rate, the type of flow at feed (flashing or suppressed), desired turndown, column height needed for flashing vapor distribution and mixing of the inlet liquid with overhead liquid.

- Single stream liquid pipe
- Multi stream liquid pipe
- Flash feed gallery
- Flash feed chamber
- Flash feed pipe

Liquid feed pipe (model LFP541/LFP542)

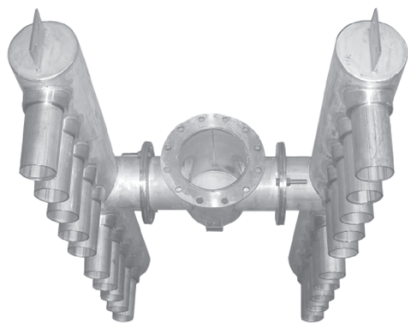

The model LFP541 feed pipe is a piping system of headers, lateral branches, and down pipes, and is used when liquid is fed from outside the column onto a distributor/redistributor. Each feed pipe meters flow to one or more appropriate feed areas, matching the hydraulic requirements of the distributor to prevent excessive turbulence and control the horizontal flow velocity in the distributor.

The LFP542 feed system employs a feed pipe that feeds a parting box or a calming box, which in turn feeds a distributor. It can operate over a wider range of flow rates as compared to the model LFP541, but it may require slightly more tower height. The LFP541/542 is attached to an internal column flange and/or by tower wall clips.

Single stream feed pipe (model LFP543)



This model is used in small columns to irrigate distributor. In the form of long or short elbow, it can be attached using a flange inside a column or a bayonet construction, which facilitates easy installation.

For small diameter column we also provide single point feed pipe as per customer requirement.

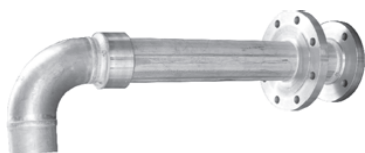

Flash feed gallery (model FFG543)

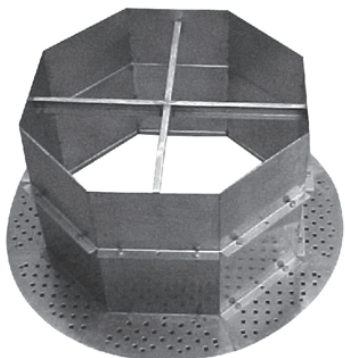

The model 543 Flash feed gallery is a two-phase feed device fed by a tangential inlet tower nozzle or a radial nozzle with a flow deflector. A gallery below provides the residence time necessary to disengage the gas and the liquid. Liquid is then fed to a distributor or into pre-distributor (parting box). This model is recommended in towers > 900 mm (36 inches) ID. It can handle any liquid to vapor feed ratio.

The inside of a gallery may be round or polygonal. The gallery is clamped to a ledge/support ring. Our flash feed galleries are typically seal welded after installation but fully gasketed construction is also available.

Flash feed chamber (model FFC544)

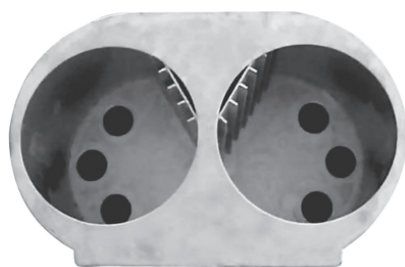

The model 544 Flash feed chamber is a two-phase feed device used in small columns, typically < 1200 mm (48 inches) ID. The feed enters through a radial inlet and is centrifuged in the chamber with the vapors coming out of the top. Disengaged liquid is fed from the bottom of the flashing feed chamber to a distributor/redistributor below. For towers between 250–530 mm (10–20 inches) ID, the 544 is constructed in one piece; multi-piece construction is used for larger towers.

The model can be attached to an internal column flange and further supported by the tower wall clips.

Flashing feed pipe (model FFP545)

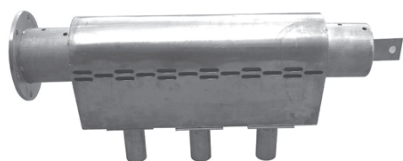

The model 545 Flashing feed pipe is used to separate two phase feed when the inlet flow is in a separated flow region. Here, the two-phase flow enters a center pipe, the vapors are released from the upper area of the pipe, and the liquid flows to the outer chamber where it is fed to the distributor/pre-distributor below.

The compact design of this model makes good use of available tower height.

The model 545 is connected to an internal tower flange and is commonly supported by a tower wall clip. This device is constructed in one piece, provided access diameter is sufficient. Alternately, multi-piece construction with gasketing can be supplied.



Collectors/Chimney trays

Liquid collection between packed beds and trays is frequently required. Liquid collectors are used in three main applications:

- For total draw-off of liquid as a product, to provide the feed to a reboiler, or for pump-around sections
- Partial draw-off of liquid with overflow of the remaining liquid continuing down the tower
- Collection of liquid for mixing

- Riser deck collector tray
- Vane collector tray

Collector trays come in different design styles to meet the needs of specific applications.

Liquid collector tray (model LCT551)



This deck type liquid collector is versatile and can be used in all towers. Liquid volume and residence time are controlled by utilizing tall risers on the tray deck. Sumps can be added on one side, both sides, or across the center to facilitate liquid withdrawal. This collector can provide 25 to 40% open area. Mid-span support beams are required in large columns > 2000 mm (78 inches) ID.

The deck and optional sump(s) rest on a ledge/tray support ring and the plate can be seal welded. Gas risers can be made in sections/pieces to allow installation through a manhole where they can be subsequently welded to the seal welded deck.

Vane collector tray (model VCT552)

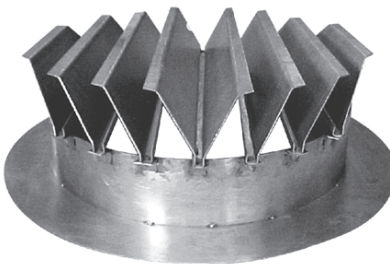

The model is used in towers that process high vapor loads and low liquid loads (vacuum service). The vane blades collect the overhead liquid and direct it into an annular sump, which may then be withdrawn from the tower or fed to a distributor below using an appropriate feeding system. It offers minimal pressure drop and it can provide open areas from 40–75%. It also minimizes entrainment, even at high vapor rates as is common with traditional gas risers in this type of service. The vanes rest on an annular sump and are fastened to clips provided on the sump. The sump is welded to tower wall and is generally supplied by the column vendor as a tower attachment. For larger towers and high liquid rates, one or more collection troughs are added, spanning across the annular sump to reduce liquid gradients.





Support plates

Support plates are provided to physically support the cumulative weight of the random/structured packings and the operating “liquid hold-up” in the packed bed. Support plates are shaped and designed to provide maximum open area and minimal pressure drop. Factors that influence the choice and design of the support plate include the column diameter, design loads (mechanical and hydraulic), packing type, liquid hold up, and system corrosivity.

Gas injection support plates used extensively in random packed beds, provide separate pathways for gas and liquid, thus reducing pressure drop across the support plate. These are the preferred type of random packing support plate and are used in majority of process applications. An available light duty support plate is used only for very small columns and where mechanical and hydraulic loading is not severe.

All support plates rest directly on a ledge/support ring since the weight of the packing is usually sufficient to keep the support plate in place. If required however, they can be clamped to the support ring. This is typically done for services where pressure surges may dislodge a packed bed. We can supply support plates in metal or thermo plastic materials.

- Support plate for random packing
- Support grid for structured packing

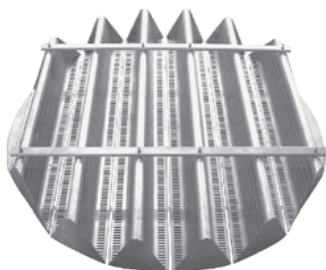

Support plate (model SPL521)

- Recommended for plastic and metallic random packed towers with more than 900 mm diameter.
- Supported with I beams for tall beds along with support ring.

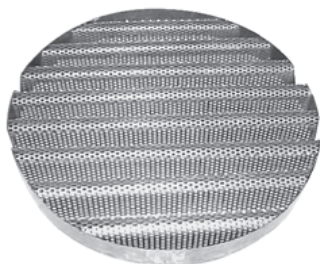

Support plate (model SPM522)

- Recommended for plastic and metallic random packed towers with less than 900 mm diameter.
- Can rest freely on the ledge or be clamped to support ring.



Support plate (model SPS523)

- Recommended for plastic and metallic random packed towers with less than 900 mm diameter.
- Can rest freely on the ledge or be clamped to support ring.



Support grid (model SGS524)

- Recommended for structured packed towers for various sizes.
- Supported with I beams for tall beds along with support ring.



Bed limiters

Bed limiters and hold down plates are retaining devices used above packed beds to prevent fluidization and restrict packing movement, which can occur during upset conditions. Bed limiters are used for metal and plastic random packings as well as structured packings.

They are fastened to the column wall by means of a support ring or bolting clips. They can also be suspended on tie rods from the liquid distributor. In place of bed limiters, anti-migration bars may also be used at the bottom of the gas risers of a distributor. They do not prevent fluidization of the bed but prevent the random packing elements from being blown up through the gas risers.

Bed limiters are designed to provide high open-area and reduce interference to liquid flow. They should be designed to withstand upward forces acting on the packed bed.

Hold down plates are used for ceramic and carbon packings. They rest directly on packings and prevent packings from breaking up due to fluidization when operated at high pressure drops or during temporary surges.

- Bed limiter for random packing
- Hold down grid for structured packing

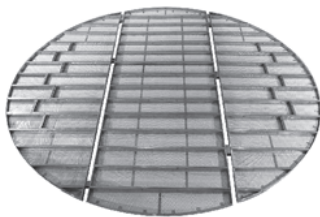

Bed limiter (model BLR531)

- Recommended for plastic and metallic random packing.
- Can be clamped to ledge/support ring or can be expandable with jack screws tighter on column wall.



Hold down grid (model BLS532)

- Recommended for structured packing.
- Bolted to column wall with vertical clips.

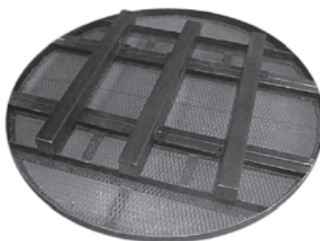

Hold down plate (model HDP533)

- Recommended for ceramic or carbon random packing.
- No clamping arrangement needed, held by weight bars in place.





Internals for liquid – liquid extraction

Packing is used in counter-current liquid/liquid contactors to facilitate mass transfer. The heavier phase is introduced from the top, flows downward and exits the column at the bottom. The lighter phase on the other hand, enters at the bottom and exits the column at the top.

Depending on the process, one of the liquids is the continuous Phase and the other is dispersed phase. Special internals are used to introduce the two liquid phases, especially the dispersed phase. Selection & arrangement of the internals depends on which phase (light or heavy) is continuous, and which is dispersed. In all cases, the use of feed pipes for directing the feed, light and heavy, to the disperser are recommended to control velocity.

In contactors where the light phase, feed which enters the bottom of the tower, is dispersed, packed beds are supported by the model 561 disperser support plate. In addition to supporting the packing, the plates allow proper dispersion or formation of small droplets that rise through the continuous phase. In breaking the dispersed liquid into small droplets, the model 561 are recommended where a total of more than 8 ft (2.5 m) of packing is required.

When the heavy phase, feed which enters the top of the tower, is dispersed, the model 562 disperser plate is used above the top bed. When multiple beds are required, the model 562 is also used to support the upper beds, collect, and disperse the heavy phase to the beds below.

The bottom bed is supported by conventional support plate (see models SPL521 or SPM522). The model 562, although structurally different, is hydraulically inverted when compared to the model 561. In heavy phase dispersed contactors, the same bed depth recommendations apply as with light phase dispersion.

It is generally recommended to disperse the phase with the higher flow rate to generate maximum interfacial contact. The exception to this rule is when the higher volumetric flow rate phase has higher viscosity or preferentially wets the packing surface or at extreme conditions (like flammable/exotic nature etc.)

- Disperser plates
- Feed pipes

Light phase disperser (model LLE561-LP)

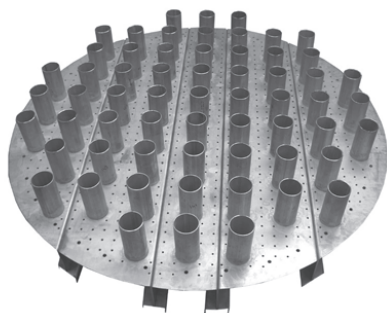

This model is used when the heavier phase is dispersed (the lighter phase is continuous) and therefore, must be located at the bottom of the packed bed. It serves the twin purposes of a disperser and a support plate. Downcomer tubes allow the heavy phase to travel downward through the plate. The light phase forms a pool or a coalesced layer under the plate and orifices generate droplets. The plate design depends on interfacial surface tension, viscosity, and differential densities. This plate also acts as a re-disperser and a support plate in multi-bed towers. In case of random packing bed, bed limiter can be provided only for top bed. In case of structured packing bed, need of hold down grid can be eliminated as no fluidization is expected.

This plate is supported by a full ledge/support ring and is designed to support the packings. Tube restrictors of different sizes are used to prevent the packing from falling through the heavier phase downpipes.

Heavy phase disperser (model LLE562-HP)

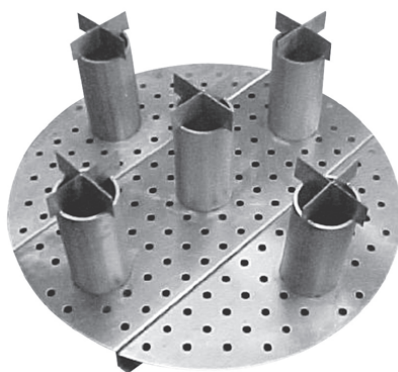

This model is used when the heavier phase is dispersed (the lighter phase is continuous) and is located at the top of the packed bed. Only a disperser plate and a standard packing support plate have to be used to support the packed bed. Riser tubes allow the light phase to travel upward through the plate. The heavy phase forms a pool or a coalesced layer above the plate and orifices generate droplets. The plate design depends on interfacial surface tension, viscosity, and differential densities. Re-disperser plates are provided in multi-bed towers. Need of bed limiter (for random packing bed) or hold down grid (for structured packing bed) can be eliminated, however in case of random packing, anti-migration is to be provided for disperser plate's up-comer pipes.

This plate is supported by a full ledge/support ring. Tube restrictors of different sizes are used to prevent the packing from passing up ward through the riser pipes for the lighter phase.

Dispersed phase feed pipe (model LFP563)



A special feed pipe arrangement for entry of dispersed phase flow inside the column. It is with header/lateral and downpipe/up-comer pipe and to be placed as per location of dispersed phase. If light phase is dispersed, model LFP563 will be at bottom below the light phase disperser plate (model 561-LP). If heavy phase is dispersed, model LFP563 will be at top of the column above heavy phase disperser plate (model 562-HP). The downpipe or up-comer pipe on header/laterals are placed such that incoming dispersed phase flow does not hinder the path of continuous phase flow through disperser plate risers.

Continuous phase feed pipe (model LFP564)

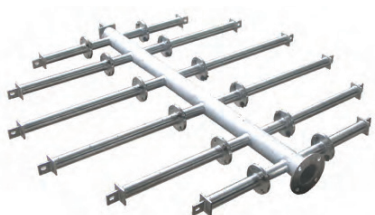

It is special feed pipe arrangement for entry of continuous phase flow inside the column. It is more like pipe arm distributor (i.e., header/laterals and orifices on it). The location of this pipe is based on which phase is continuous. If the light phase is continuous then model LFP564 shall be at the bottom of the column, below the conventional support plate (SPL521/SPM522). If heavy phase is continuous then model LFP564 shall be at the top of the column above conventional bed limiter (BLR531/BLS532). The orifice on header/laterals are placed in such a way that it covers maximum cross-sectional area.



Plastic internals

Munters offers complete solutions for Tower internals in Plastics & are capable to render various designs for Packing supports, bed limiters, distributors , collector trays & vapor feed inlet device as per specific flow requirement. With decades of experience in mass transfer solutions you can be certain our proven plastic internals products give you efficient operation & better service life.

We are well equipped with all resources in terms of design, expertise & experience required for Plastic tower internals which find their application in highly corrosive & moderate temperature service. Munters has wide range of offerings for plastic internals in various materials like PP, PVDF, PTFE, FRP, CPVC, PVC etc. which are designed to not only provide optimum performance, but are also designed for variable loadings. Other attributes of internals made from plastic are light in weight & chemical resistance which makes it the ultimate choice for process engineers in variety of applications.

Munters can offer both standard as well as customized designs of internals for towers, and able to carry out calculations along with review of column drawings and tower attachments for our customers.

- Bed Limiter
- Support Plate
- Liquid distributors
- Feed pipe arrangement
- Collector Tray

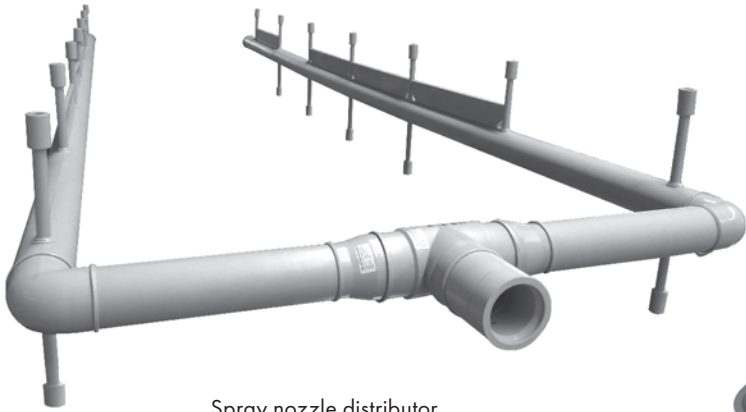

Spray nozzle distributor

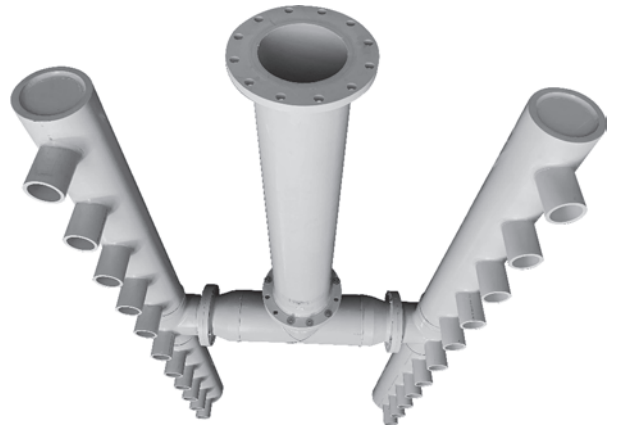

Liquid feed pipe

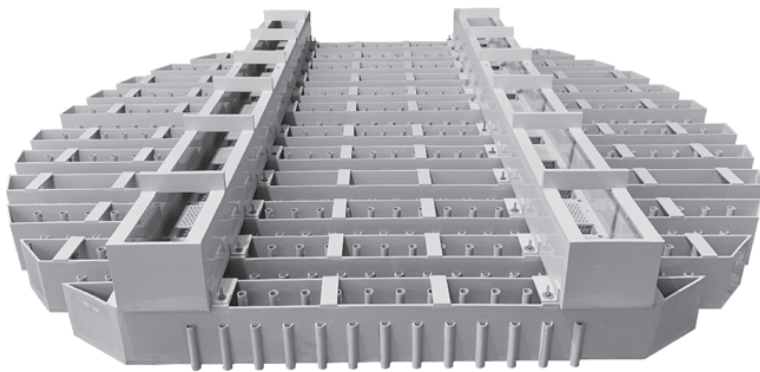

Trough type distributor with parting box



Deck type re-distributor

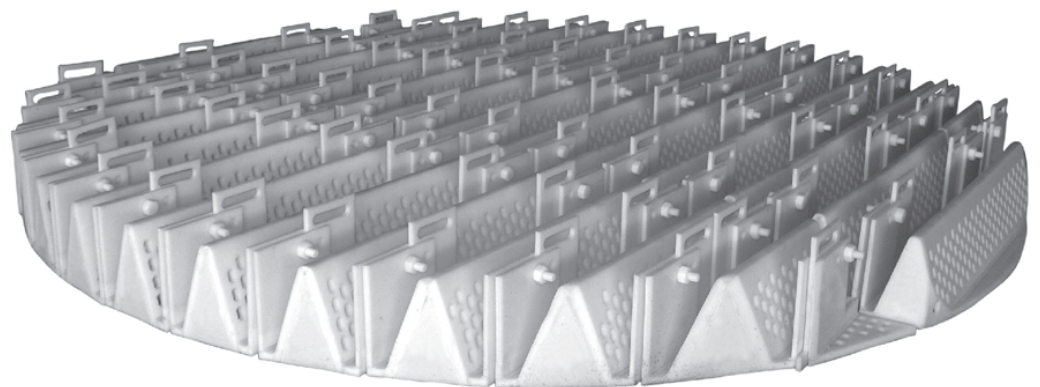

Support plate



Mist eliminators

Often in industrial applications, gaseous streams carry mist, this is known as entrainment. Mist causes severe technical problems in a process such as reduced process efficiency, physical damage to downstream components and loss of product and process fluids.

A mist eliminator is a device used to remove these entrained liquid droplets from the fluid stream.

Please refer to our *Mist eliminators* catalogue for detailed product information.



Services

With Munters as your service partner, you will achieve the longest possible lifetime for your mass transfer equipment.

No matter what phase of the life cycle your Munters equipment is in, our service solutions and products will provide optimal operation and performance for as long as you need, and beyond.

- Feasibility study
- Design and drafting
- Site installation
- Troubleshooting

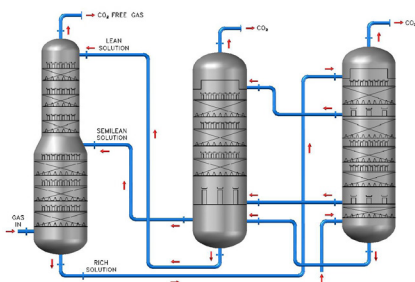

Feasibility study

We are equipped to carry out complete feasibility studies for new and revamp projects. Our range of services include process simulation, hydraulic design of columns, mechanical design, and preparation of drawings. Whether it is the design or rating of absorbers, strippers, fractionators or extractors, our vast experience in varied industries has helped us develop a strong database in various mass transfer applications.

Design and drafting

Appropriate selection and sizing of equipment for new projects or capacity increase/de-bottlenecking of existing plants are of utmost importance for optimum operation, success, and viability of the plant. Munters caters to the process design needs of these plants. With in-house software, Munters is fully capable of providing hydraulic rating to packed columns, tray columns, and column internals.

The availability of modern design software and in-house high-tech automation allows us to select the best option to perform design and drafting service for any type of mass transfer equipment. We have experience in designing and drafting various types of packed column internals and trays, including high-performance distributors/Re-distributors, chimney trays, high-capacity valve trays, baffle trays, and more. Our in-house engineering and manufacturing capabilities promote efficient lines of communication between our mechanical and production departments.

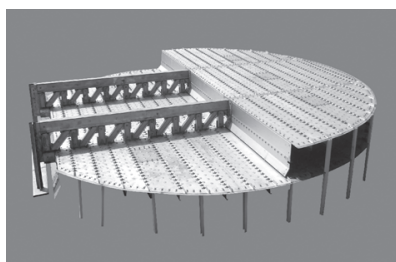

Site installation

We provide installation services for new projects and revamp jobs pertaining to packings, trays, and internals. Our team are experts in the installation of all our own products and if the need arises, we also assist in the installation of products not designed and supplied by us.

Installation consulting services are available upon request when the installation of our mass transfer products is performed by others. We aim to provide quick and reliable solutions to unforeseen problems that may arise during installation. Please contact our sales representative for more details related to this service.

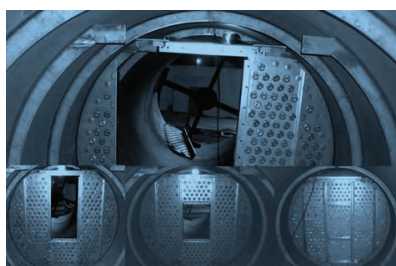

Troubleshooting

You can rely on us for guidance on any design, operation, and maintenance-related problems. Our mass production manufacturing capabilities for components such as packings, valves, etc. will ensure emergency replenishment requirements can be met during planned and unplanned shutdowns.



End users

Munters has supported many companies all over the world over the years. Our profound expertise has helped them mass transfer their problems into solutions.

Some companies using Munters supplied mass transfer equipment include:

Abu Dhabi Gas Industries (GASCO)	GE Water	Petrobras, Paulina Refinery (REPLAN)
Abu Dhabi National Oil Company	GM Green Methane S.R.L.	Petroleo Brasileiro SA (Petrobras)
Abu Dhabi Oil Refinery (TAKREER)	Godrej Industries Ltd.	Petroleos Mexicanos (PEMEX)
Abu Dhabi Polymers Co. Ltd. (Borouge)	Grande Pariosse	Petronas Carigali Sdn Bhd (PCBS)
Acron Refinery	Grasim Industries Ltd.	Petroquimica Uniao sa (PQU)
Advanced Vacuum Systems, Inc.,	Gujarat Fluorochemicals Ltd.	Petrovietnam Fertilizer & Chemicals Corporation
A.H.Lundberg System Ltd.	Haldia Petrochemicals Ltd.	Potencial Biodiesel (Lapa-PR)
Air Products And Chemicals INC	Heavy Industries Enterprise (HIE)	Praxair
Airgas (Air Liquide)	Heavy Water Board	Qatar Fertilizer Co. S.A.Q. (QAFCO)
Arkema	Hexion INC	Qatar Petrochemical Company (QAPCO)
Axiall Corporation	Hindustan Petroleum Corporation Ltd.	Rashtriya Chemicals & Fertilizers Ltd.
Babcock & Wilcox MEGTEC LLC	HPCL-Mittal Energy Ltd.	Reliance Industries Ltd.
Bahrain Petroleum Company	Idemitsu Kosan Global	Repsol YPF, Cartagena Refinery
BASF	Indian Farmers Fertilizers Co-Operative Ltd.	Rubicon LLC.
Bharat Oman Refineries Ltd.	Indian Oil Corporation Ltd.	Rukun Al Yamaani Environmental Services LLC
Bharat Petroleum Corporation Ltd.	Indorama Eleme Fertilizers & Chemicals	Ruwais Fertilizers Industries Ltd. (FERTIL)
BHP Nickel West	Intercell	Saudi Arabian Fertilizer Co. (SAFCO), National Chemical Fertilizer Co.
Brahmaputra Cracker and Polymer Limited	JSC Mozyr Oil Refinery	Saudi Basic Industries (SABIC), IBN Zahr Plant
Burrup Fertilizers	Jubail Chevron Phillips Co (JCP)	Saudi Formaldehyde Chemicals Co Ltd.
Cadila Healthcare Limited	Krishak Bharti Cooperative Ltd.	Sepeco Process Inc.
Canadian Natural Resources Limited.	Kuwait National Petroleum Company, Mina Al-Ahamadi Refinery	Sharptech
Cheminova	Kuwait Oil Company	Socar LLC
Chennai Petroleum Corporation Limited	Lamprell Energy Ltd. (Aker Floating Production)	Sohar aluminium LLC/ Sohar Power
Cofco International	Lukoil	Solvay
Coromandel International Limited	Mangalore Refinery & Petrochemicals Ltd.	Southern Ionics LLC, Willamsport, Marylands
Dangote Oil Refining Company	Marathon Petroleum	State Oil Company of Azerbaijan Republic
Dolphin Energy Ltd.	Methanex	Syzran Refinery
Dow Chemical Company	Mitsubishi Chemicals	TCI Sanmar Chemicals LLC
Dr. Reddy's Laboratories Ltd.	Molecular Rebar	Teva Pharmaceuticals Works Pvt. Ltd.
Dupont Agricultural Caribe Ind. Ltd.	Naftan Refinery	Thai Peroxide Limited
Eco Oils Sdn. Bhd.	NALCO Pacific Pt. Ltd., Jurong Island	The Bahrain Petroleum Co Ltd.
Ecomar Energy Solutions FZC	National Fertilizers Ltd.	The Dow Chemical Company
EMAS Offshore Construction & Production PTE. Ltd.	Numaligarh Refineries Ltd.	The National Titanium Dioxide Co. Ltd. (CRISTAL)
Emperador Distiller Inc.	Oil & Natural Gas Corporation Ltd.	UOP
Energy Oil	Oman India Fertilizer Co (OMIFCO)	Yara Fertilizer
ENI Sannazaro Refinery	Oman Refineries and Petrochemicals Company (ORIPIC), Sohar Refinery Co LLC	
Essar Projects Ltd.	Palm - Oleo (Klang) Sdn. Bhd.	
Eurocan SRL.	PBF Energy	
Ezz Rolling Mill		
Falcon Chemicals L.L.C.		
Galaxy Chemicals		
Gazpromneft		



Munters Services – With you all the way

With Munters as your service partner, your air treatment equipment will receive the attention, care and maintenance needed to reach its maximum life expectancy. Throughout each phase of the equipment life cycle, the knowledge and expertise of Munters Services will insure optimal operation, minimum energy consumption, and extension of the life of your investment.

Our range of services available through our global network of Munters Services Engineers and Technicians include:

- Comprehensive installation and start-up services
- PrimaCaire™ (extended warranty) agreement
- Flexible ServiceCaire™ maintenance agreements to fit your specific needs
- Performance checks and optimization
- Numerous upgrade options for substantial energy savings and improved performance

Find your nearest Munters office at www.munters.com

Munters reserves the right to make alterations to specifications, quantities, etc., for production or other reasons, subsequent to publication. © Munters AB, 2021