

Each Crate includes:

- 1 - 36" Belt Drive or Direct Drive Fan or 48" Belt Drive Fan
- 1 - Hardware Package (HP1082) includes:
12 - ¼" x 1.5 Lag Screw, ZP

Fan Specifications:

Power: 120/240 VAC or 208-240/480 VAC
Phase: 1 or 3
Hertz: 60 or 60

NOTE: Crate may contain Fan Accessories.

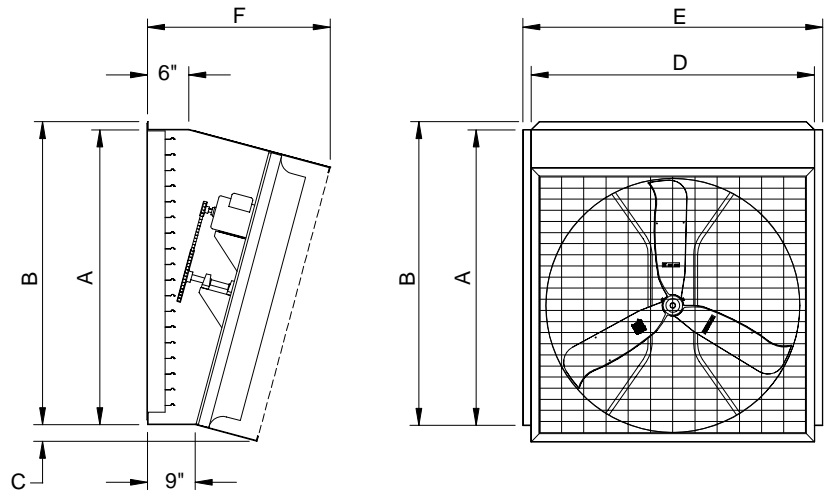

CAT. NO.	FAN DIA.	A	B	C	D	E	F	Wall Opening (I.D., framed)
xx36T	36"	44¼"	45¾"	3¼"	42¼"	45¼"	34"	43" W. x 45" H.
xx365T	36"	44¼"	45¾"	3¼"	42¼"	45¼"	34"	43" W. x 45" H.
xx481T	48"	56¾"	58¼"	4"	54¼"	57¼"	36½"	55" W. x 57½" H.
xx4815T	48"	56¾"	58¼"	4"	54¼"	57¼"	36½"	55" W. x 57½" H.

UNPACKING THE EQUIPMENT

Before beginning installation, check the overall condition of the equipment. Remove packing materials, and examine all components for signs of shipping damage. Any shipping damage is the customer's responsibility and should be reported immediately to the freight carrier.

INSTALLATION INSTRUCTIONS

⚠ WARNING

ROTATING FAN BLADES.
Operation of fan without wire screens or guards may result in direct contact with blades and cause severe personal injury or death.

- 1) Construct the framed opening to correct size according to the above chart and your fan size. **See Figure 1.**

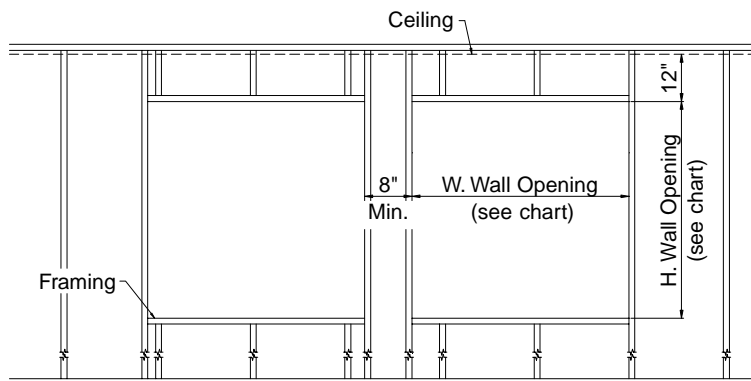

Figure 1

- 2) Insert fan into the framed opening from the inside and fasten with 1/4" x 1.5 Lag Screws (provided). Install flashing around opening tight to fan and caulk around fan to seal. **See Figure 2.** Proceed to Electrical Wiring Section before installing the shutter.

SHUTTER INSTALLATION:

- 3) Insert shutter into housing **See Figure 3.** Rotate shutter clips down over shutter flange to secure it in place. Gently push shutter blades open by hand, checking for smooth operation. **See Figure 4.**

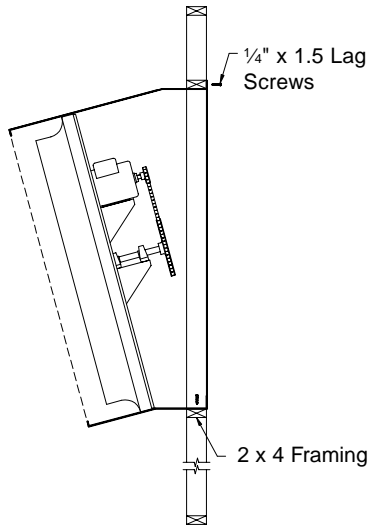

Figure 2

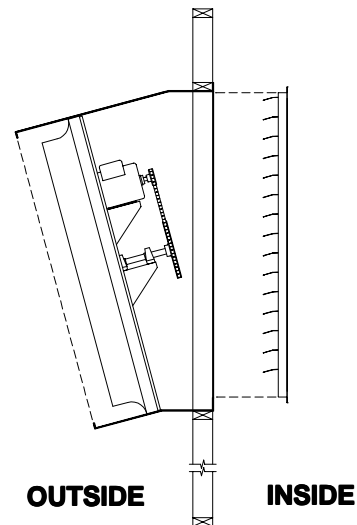

Figure 3

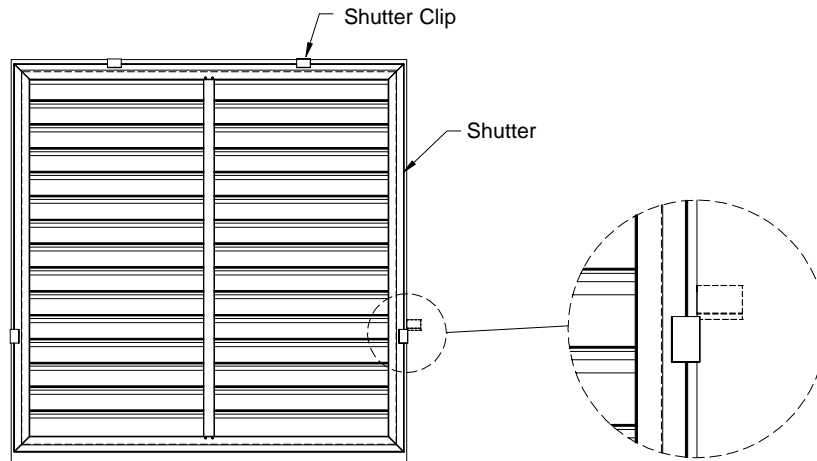

Figure 4

ELECTRICAL WIRING



All wiring should be installed in accordance with National, State, and Local electrical codes. Fans used to ventilate livestock buildings or other rooms where continuous air movement is essential should be connected to individual electrical circuits, with a minimum of two circuits per room. For electrical connection requirements, refer to diagram on motor nameplate and to information enclosed with the Aerotech environmental control to be used.

Single Phase Fans: motor overload protection should be provided for each fan. A Circuit Breaker Switch or slow blow motor type fuses must be used **See Figure 5 (on page 3).** See Aerotech form **QM1400** for proper size. **NOTE:** A safety cut-off switch should be located adjacent to each fan.

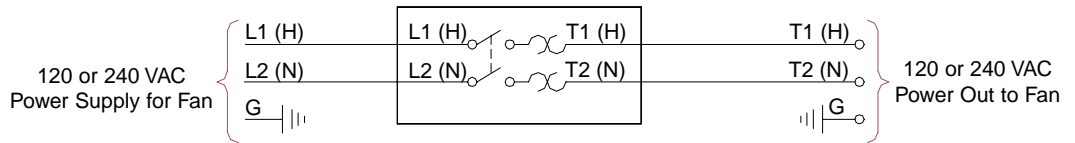

Figure 5

Single Phase - Motor Overload Protection with Disconnect (SY2000 or Equivalent)

KEY:

L1 = Line 1 H = Hot
 L2 = Line 2 N = Neutral
 G = Ground

NOTE: Information in parenthesis refers to 120 VAC control.

Three Phase Fans:

- 1) 36" Direct Drive, 3 Phase fan is not suitable for frequency drive.
- 2) The use of a quality frequency drive and the installation of line reactors is recommended to reduce voltage spikes and harmonic distortion.
- 3) Minimum operating frequency of 30 Hz.
- 4) Will require three pole contactors with overload protection (by others) if a frequency drive is not used.

»Install shutter at this time, go back to Step 3 in the Installation Instructions Section.

OPERATION



- 1) **INITIAL START-UP:** With electrical power off, verify that the fan propeller turns freely and that all fasteners are secure. Turn on electrical power and confirm that the fan operates smoothly.
- 2) **ADJUSTMENTS:** Set the fan control to the temperature shown on your Aerotech ventilations system drawing, or to a value which will provide the desired environmental conditions.
- 3) **BELT ADJUSTMENTS:** After 3 days of operation you must tighten fan belt. See Maintenance Section: Belt Tension.

Single Phase Fans: When variable speed controls are used, the fan's idle speed will need to be set to the recommended minimum airflow rate. Refer to the procedures included with each control. The table below provides airflow rates for **AX36T** at various propeller speeds for fans wired for 240 VAC.

A = Fan with cone & shutter B = Fan with hood & shutter

CFM	0.02" Static Pressure				0.05" Static Pressure			
	A		B		A		B	
	RPM	VOLTS	RPM	VOLTS	RPM	VOLTS	RPM	VOLTS
750	—	—	—	—	—	—	350	121
1000	—	—	—	—	370	123	390	128
1250	330	117	330	119	390	127	410	130
1500	360	123	360	125	410	131	430	134
1750	370	125	370	127	425	136	440	136
2000	380	128	390	130	450	137	460	139
2500	410	131	420	135	470	141	480	143
3000	430	135	440	138	490	145	500	146
4000	470	142	480	145	520	149	530	151
5000	520	148	530	152	560	156	570	158
6000	560	154	580	159	590	161	600	162
7000	610	159	640	165	640	166	680	172
8000	650	166	700	173	690	172	750	179
9000	710	172	760	185	740	178	810	209
10,000	770	179	840	225	790	195	—	—
11,300	840	223	—	—	—	—	—	—

MAINTENANCE

⚠ WARNING



High Voltage,
disconnect power
before servicing.

⚠ WARNING



Moving parts,
disconnect power
before servicing.

⚠ WARNING



Do not power wash
electrical devices.

⚠ WARNING



Moving parts,
disconnect power
before servicing.

The following inspection and cleaning procedures should be performed monthly:

- 1) **INSPECT PROPELLER:** Check that propeller is secure on motor shaft and that there are no signs of damage. The blades are of a self-cleaning design and should not require maintenance.
- 2) **CLEAN** regularly for best results:
 - **FAN MOTOR:** Remove any dust accumulation from motor using a brush or cloth. (**DO NOT** use a pressure washer). A clean motor will run cooler and last longer. At the same time, verify that the motor is secure in its mount.
 - **SHUTTER:** Carefully clean dust from shutter blades and frame so that shutter opens and closes freely. A brush or cloth should be used.
 - **GUARD:** Clean any dust or feathers from fan guards using a brush. Dirty guards can reduce airflow.
- 3) **CHECK FASTENERS:** For safety, all fasteners should be inspected. Tighten any loose connections.
- 4) **INSPECT FAN CONTROL:** With power disconnected, inspect all electrical connections. Wiring should be secure and in good condition. Remove any dust build-up from control case and sensor using a soft brush or cloth. **NEVER CLEAN ELECTRICAL EQUIPMENT WITH A PRESSURE WASHER!**

- 5) **GREASE BEARINGS:** Grease bearings every 4-6 months. Use no more than 2 shots when greasing fan.

- A premium non-water based grease is recommended:

- Shell Alvania #2	- Mobil Mobilux #2
- Exxon Unirex N2	- Texaco Premium RB
- Mobil 532	- Texaco Multifak #2

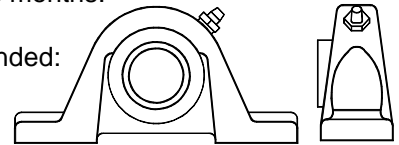

- 6) **CHECK DRIVE ALIGNMENT:** Use a straight edge to check the alignment of the pulleys. If an adjustment is needed, remove the belt, then loosen the set screw in one pulley and move it. Remember to tighten the set screw after making an adjustment. Drive alignment is very important for long belt life and proper operation.

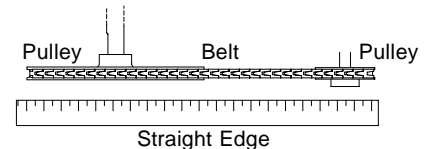

- 7) **CHECKING PULLEYS:** Roll the belt off and look at both pulleys. If the pulley has grooves in it or is no longer smooth, it needs replacement. A loose or slipping belt will reduce fan performance up to 60% and cause premature belt failure.

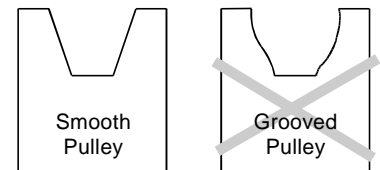

- 8) **BELT TIGHTENING:** All belts must be checked for proper tension after the first 3 days of fan operation and every 4-6 months thereafter.

- Roll the belt off the pulleys by forcing it side ways off the larger pulley as you turn the drive by hand.
- Reinstall the belt by wrapping it around the smaller pulley and then starting it over the larger pulley.
- As you continue rolling it onto the larger pulley, the belt should become taut in the position shown below.
- If the belt becomes taut before reaching the position shown, add one link and try again.
- If the belt is still loose when in the position shown, remove one link and try again.

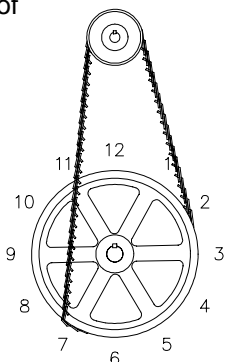

Apex & Grower Fans

AEROTECH, INC.

4215 Legion Dr. Mason, MI 48854-1036 USA
(517) 676-7070 Fax (517) 676-7078

FORM: QM1060

Rev. 1, January 1999
Page 4 of 5

WINTERIZING FAN

In most climates, it is probable that the ventilation system will never need to operate at a total capacity during the colder winter months. Consequently, it is advisable to "winterize" those fans which will not be used in cold weather to avoid unnecessary heat loss and condensation.

To winterize, turn fan control "off". Install the insulated closure panel over the fan intake. If you don't have an insulated closure panel, a piece of rigid insulation material can be used. **Remember the insulation panel must be removed before warmer weather returns.**

NOTE: At least one single speed fan should be left uncovered and with power available to provide air movement in the event of variable speed control difficulties.

TROUBLE SHOOTING

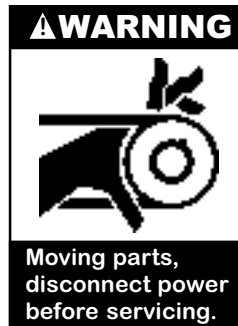

SYMPTOM	POSSIBLE CAUSES	CORRECTIVE ACTION
Fan Not Operating	<ol style="list-style-type: none"> 1. Fan control set above room temperature 2. Blown fuse or open circuit breaker 3. Propeller blade contacting fan housing 4. Fan control defective 5. Motor defective 	<ol style="list-style-type: none"> 1. Set to a lower temperature 2. Replace fuse or reset breaker 3. Realign propeller in fan housing 4. Repair or replace control 5. Repair or replace motor
Fan Operating-Insufficient Airflow	<ol style="list-style-type: none"> 1. Variable speed control improperly adjusted 2. Shutter jammed 3. Guard dirty 4. Incorrect Belt Tension 	<ol style="list-style-type: none"> 1. See Operation, Step 2 for adjustment guidelines 2. Clean shutter & fan housing 3. Clean guard 4. See Maintenance Section, Belt Tightening
Excessive Fan Noise	<ol style="list-style-type: none"> 1. Variable speed control idle speed set to low 2. Variable speed control defective 3. Propeller blade contacting fan panel 4. Motor bearing defective 	<ol style="list-style-type: none"> 1. Increase idle speed setting 2. Repair or replace control 3. Realign propeller in fan housing 4. Repair or replace motor
Excessive Fan Vibration	<ol style="list-style-type: none"> 1. Motor loose in mount 2. Propeller damaged 3. Motor shaft bent 	<ol style="list-style-type: none"> 1. Tighten fasteners 2. Replace propeller 3. Repair or replace motor
Fan Never Turns Off	<ol style="list-style-type: none"> 1. Override thermostat set incorrectly 2. Control set for continuous operation 	<ol style="list-style-type: none"> 1. Set to the correct temperature 2. Set speed control correctly

WARRANTY: See Aerotech, Inc. Limited Warranty Statement

AEROTECH, INC.

4215 Legion Dr. Mason, MI 48854-1036 USA
(517) 676-7070 Fax (517) 676-7078

FORM: QM1060

Rev. 1, January 1999
Page 5 of 5