



Munters mass transfer products

We mass transfer your problems into solutions



About Munters mass transfer 04

Products 05

TOWER TRAYS

Valve Trays	06
Sieve Trays	07
Bubble Cap Trays	07
Hardwares & Fasteners	08

TOWER PACKINGS

RANDOM PACKINGS

Medal-Pak	09
Tierce Ring	09
Tall-Pak	10
Pall Ring	10
Omni-Pak	10
Saddles	11
Raschig Ring	11

STRUCTURED PACKINGS

ME-II Series	13
Vantage Series	13
Vantage <i>Additional</i> Series (High Capacity)	14
ME-II Wire Mesh Series	15
Grid Packing Series	15

TOWER INTERNALS

LIQUID DISTRIBUTORS

Importance of Liquid Distribution	16
Pan Type Distributor/Redistributor (Model DPC501/RPC502)	18
Riser Deck Distributor/Redistributor (Model DRD503/RRD504)	18
Trough Type Distributor with Parting Box (Model DTP505)	19
Trough Type Distributor/Redistributor with Sump (Model DTS506/RTS507)	19
Trough Type Distributor/Redistributor with End Closure (Model DTE508/RTE509)	20
Flow Multiplier Distributor/Redistributor (Model DFM510/RFM511)	20
V-Weir Distributor/Redistributor (Model DVW512/RVW515)	20
Spray Nozzle Distributor (Model DSN513)	21
Pipe Arm Distributor (Model DPA514)	21

VAPOR DISTRIBUTORS

Importance of Vapor Distribution	22
Vapor Feed Distributor (Model VFD546)	22
Vapor Distribution Plate (Model VDP547)	22
Vapor Inlet Device (Model VID808)	22

TABLE OF CONTENTS

FEED DEVICES

Liquid Feed Pipe (Model LFP541/LFP542)	23
Flash Feed Gallery (Model FFG543)	24
Flash Feed Chamber (Model FFC544)	24
Flashing Feed Pipe (Model FFP545)	24

COLLECTORS/CHIMNEY TRAYS

Liquid Collector Tray (Model LCT551)	25
Vane Collector Tray (Model VCT552)	25

SUPPORT PLATES

Support Plate (Model SPL521)	26
Support Plate (Model SPM522)	27
Support Plate (Model SPS523)	27
Support Grid (Model SGS524)	27

BED LIMITERS

Bed Limiter for Random Packing (Model BLR531)	28
Bed Limiter for Structured Packing (Model BLS532)	29
Hold Down Plate (Model HDP533)	29

INTERNALS FOR LIQUID - LIQUID EXTRACTION

Lighter Phase Dispenser (Model LLE561-LP)	30
Heavier Phase Dispenser (Model LLE562-HP)	31

PLASTIC INTERNALS

32

MIST ELIMINATORS

WIN - Mesh Type	33
WIN - Vane Type	34
DV 270 (T-271) Vane Type	36
Liquid Coalescers	36

CATALYST BED SUPPORTS

Alumina/Inert Balls	37
---------------------	----

Services

Feasibility Study	38
Design & Drafting	38
Site Installation	38
Trouble Shooting	38

About Munters mass transfer

We **mass transfer** your problems into **solutions**

Munters offers the complete range of mass transfer equipment, enabling solutions to all separation challenges in the process industry.

The installation of our cost effective products serve to improve the performance of our valued customer's critical distillation, absorption, liquid extraction, stripping and heat transfer processes. We serve customers in industries such as fertilizers, petroleum refineries, oil and gas, petrochemicals, fine chemicals, and pharmaceuticals throughout the world. We offer highly customized

solutions to our customers, solving the most critical separation challenges.

Munters acquired Kevin Enterprises in 2017 to broaden the scope of mass transfer equipment. The company was founded in 1972 and has consistently delivered exceptional quality of design, manufacturing and installation of mass transfer equipment to their customers. KEVIN's strong technical capabilities and expertise have been developed over a period of 15 years as a licensee of Saint Gobain - NorPro Corporation (formerly

Norton Chemical Process Products Corporation) and through their independent experience built over the period of 40 years.

During this time, KEVIN has grown to become Asia's pre-eminent mass transfer equipment company as well as preferred supplier in North America and the Middle East. Kevin Enterprises is an ISO 9001 certified company.



PRODUCTS

We offer a broad range of mass transfer products to provide you with high performance system - a tower that contains well matched components to optimize its fractionation, absorption, stripping and extraction performance.

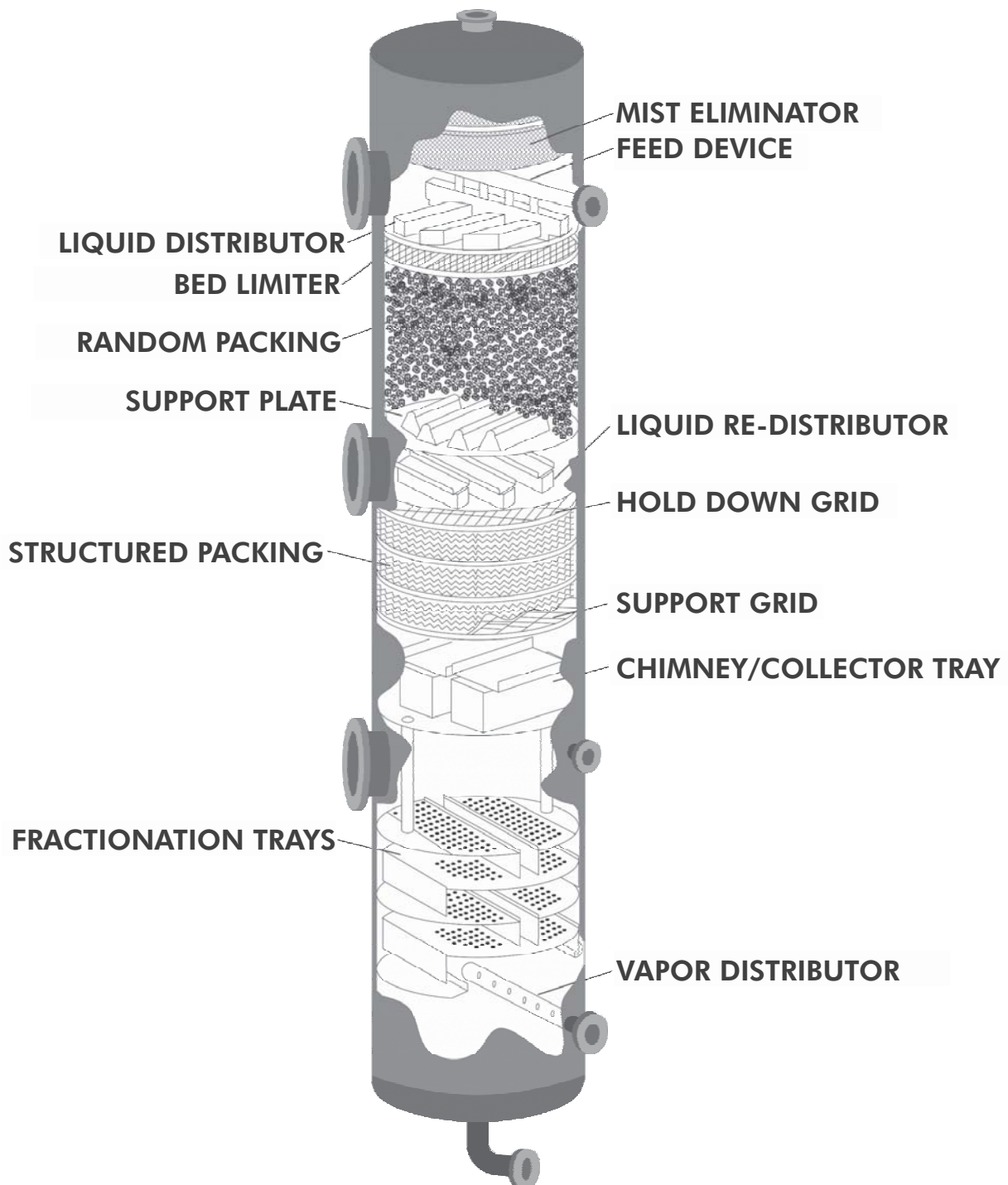

TOWER TRAYS

Trays are used in mass transfer operations where pressure drop limitations are not critical. They are mainly used in high-pressure distillation operations. However, there are a few atmospheric, moderate pressure and vacuum operations where trayed towers are used. Trays are available in segmental or cartridge type construction to suit customer's requirements.

VALVE TRAYS

The valve trays are typically with the covers provided to the perforations of the sieve trays. The valves are either moveable (conventional) or fixed. The valves provide extra resistance to the rising vapors, which are discharged laterally. This helps better interactions

with the liquid on the tray and increases efficiency. Valve trays have better turndown.

Conventional Valve Tray

The valves are either round or rectangular in shape, which moves vertically up/down to create variable lateral openings for the vapors to bubble through the liquid pool. Increase in vapor energy will move the valve in upward direction and the valves sit on the deck when vapor energy is very low. The cage valves are with the caging structure and a lighter movable disk which sits on the perforation. The disks provide lower pressure drop as it gives less resistance to the rising vapors.

These valve trays are also available with venturi option.



High Capacity Valve Tray

The fixed valve tray is a valve tray whose valve units are fixed in the fully open position and is a low-cost stationary assembly which imitates the shape of valve. They have better turn-down ratio than sieve trays. The absence of the moving disk eliminates wear and sticking, but at the expense of turndown as compared to other valve trays. The valve can be flat-dome shaped, triangular or rectangular.

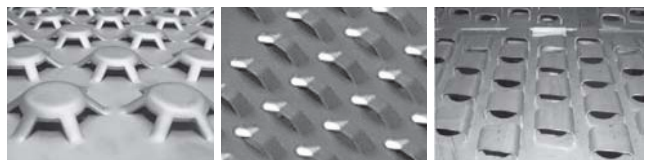

SIEVE TRAY

The sieve tray is a flat perforated plate with no moving parts. Vapor rises from the holes/ perforations to the tray above, cross-current to the liquid flow. The vapor energy keeps the liquid from flowing down through the holes. The latter moves across the tray & travels to tray below through down-comer. Sieve tray has good capacity & moderate efficiency than Valve tray & Bubble cap tray but has limited flexibility in the operating range.

The sieve size typically ranges from 1/4" to 1". Smaller sieves reduce weeping whereas larger sieves are employed in fouling services.

The major advantages of sieve tray is low maintenance cost and low fouling tendency when compared to other conventional tray. Also, Sieve tray is simple and easy to fabricate, and is relatively inexpensive as compared to other mass transfer trays.

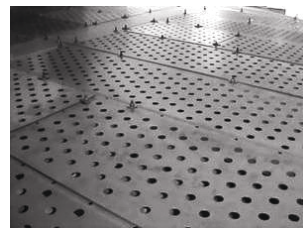
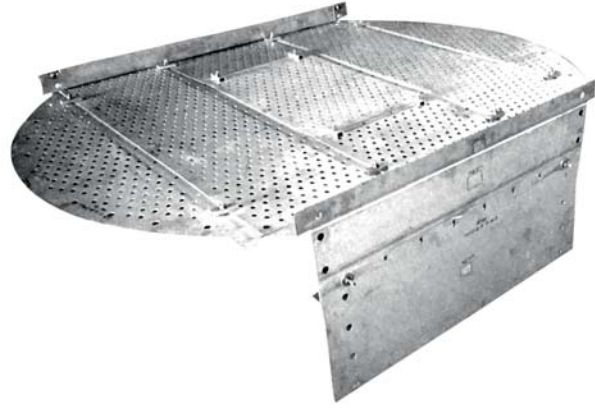

BUBBLE CAP TRAY

Bubble cap tray is a flat perforated plate with risers (like pipes) around the perforations and caps in the form of inverted cups over the risers. The caps are usually equipped with slots or holes through, which vapor comes out. The cap is mounted so that there is a space between riser and cap to allow the passage of vapor. Vapor rises through the riser and is directed downward by the cap passing through slots in the cap, and finally bubbling through the liquid on the tray. As vapor has to pass through many passages this leads to higher pressure drop & lower capacity than other conventional trays. Liquid and froth are held on the tray to a depth at least equal to the weir height or riser height, giving the bubble-cap tray a unique ability to be used for reaction applications.

Due to its construction this tray is expensive than sieve & valve trays.

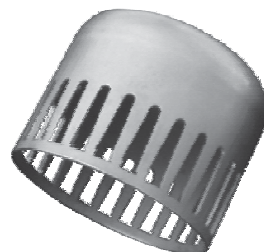

HARDWARES & FASTENERS

We also maintain a larger inventory of various types of valves and hardware for emergency delivery during your planned or unplanned shutdown



WE ARE ALSO APPROVED SUB-CONTRACTORS FOR MANUFACTURE AND SUPPLY FOR:

M/s. UOP, UK for their proprietary MD™ Trays.
M/s. Stone & Webster now "TechnipFMC", USA for their proprietary Ripple™ Trays.
M/s. Aker Kvaerner Process Systems Ltd. for their proprietary Baqe Trays.
M/s. Engineers India Ltd. (EIL) for mass transfer equipment.

TOWER PACKINGS

RANDOM PACKINGS

While packed towers have been in existence for over a century, many improvements have been developed to maximize column performance. In order to derive enhanced yields from a packed tower, one must select and install well matched components to optimize distillation, absorption or stripping performance.

MEDAL-PAK

Medal-Pak (formerly sold as IMTP[®]) gives the best of both the worlds in terms of performance (i.e. low-pressure drop and high efficiency). It can be effectively used in both high pressure and vacuum towers. Other advantages include large effective interfacial area, high mechanical strength and low cost. Its monolithic construction overcomes the problem of "opening out" at the ends as can be experienced with ring shaped packings.

Medal-Pak is available in an array of sizes to provide multiple combinations of efficiency and pressure drop. Medal-Pak can be fabricated from a variety of metals including, but not limited to, Carbon Steel, Stainless Steel, Copper, Aluminum, Titanium, Zirconium, etc.

ITEM / SIZE	SURFACE AREA m ² /m ³ (ft ² /ft ³)	VOIDAGE (%)
Medal-Pak # 15	291 (88.8)	95.6
Medal-Pak # 25	225 (68.6)	96.6
Medal-Pak # 40	150 (45.7)	97.7
Medal-Pak # 50	100 (30.5)	98
Medal-Pak # 60	74 (22.6)	98
Medal-Pak # 70	60 (18.3)	98.5



TIERCE RING

Tierce Rings are also ring type random packings but with an approximate diameter to height aspect ratio of 3:1 and are further flared along the periphery for strengthening of packing.

ITEM / SIZE	SURFACE AREA m ² /m ³ (ft ² /ft ³)	VOIDAGE (%)
Tierce Ring # 1	250 (76.2)	96
Tierce Ring # 1.5	190 (57.9)	96
Tierce Ring # 2	150 (45.7)	97
Tierce Ring # 2.5	125 (38.2)	97
Tierce Ring # 3	102 (31.1)	98



TALL-PAK

Tall-Pak (formerly sold as Hy-Pak®) is an excellent substitute for traditional Pall Rings and is considered to be one of the most efficient ring-type random packings. At almost the same efficiency, it provides lower pressure drop than a Pall Ring. It also increases the interfacial area available for gas-liquid contact. Its unique design incorporates

strength reinforcing ribs that allow for lower thickness and taller beds, thus reducing procurement costs when compared to traditional Pall Rings.

ITEM / SIZE	SURFACE AREA m ² /m ³ (ft ² /ft ³)	VOIDAGE (%)
Tall-Pak # 1 (30mm)	171 (52.2)	96.5
Tall-Pak # 1.5 (45mm)	118 (36.0)	97
Tall-Pak # 2 (60mm)	84 (25.6)	97.8
Tall-Pak # 3 (90mm)	57 (17.4)	98



PALL RING

Pall Rings are traditional ring type random packing with global installed base and well documented performance history. They are available in metal & plastic material.

ITEM / SIZE	SURFACE AREA m ² /m ³ (ft ² /ft ³)	VOIDAGE (%)
Metal Pall Ring 10mm (3/8")	482 (147.0)	92.8
Metal Pall Ring 16mm (5/8")	344 (104.9)	93.1
Metal Pall Ring 25mm (1")	206 (62.8)	94.8
Metal Pall Ring 38mm (1.5")	130 (39.7)	96.0
Metal Pall Ring 50mm (2")	102 (31.1)	95.9
Metal Pall Ring 90mm (3.5")	66 (20.2)	95



OMNI-PAK

Omni-Pak (formerly sold as Snowflake®) is a high-performance plastic packing. It offers superior efficiency and capacity in environmental application such as scrubbing and stripping. Its distinctive shape lowers the pressure drop, which significantly reduces electrical energy consumption. Its various applications include fume scrubbing, acid gas absorption, VOC stripping, wastewater treatment, flue gas scrubbing, etc. It gives higher efficiency compared to Pall Rings 38 mm (1.5") and Plastic Super Saddles and larger.

ITEM / SIZE	SURFACE AREA m ² /m ³ (ft ² /ft ³)	VOIDAGE (%)
Omni-Pak	100 (30.5)	95

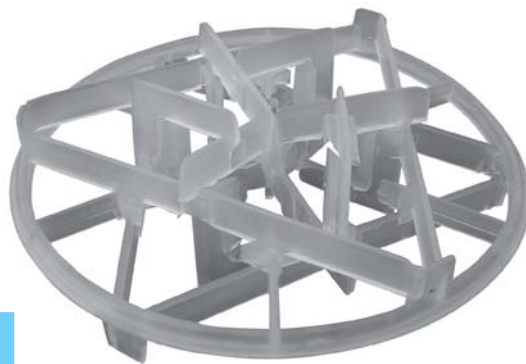

SADDLES

Plastic Super Saddles (PSS) are the improvised version of the original saddles. They are designed to give enhanced internal gas and liquid distribution. The unique scalloped edge is the key to the product's high performance in terms of high capacity and improved rates of mass transfer when compared to traditional plastic saddles. It also serves to overcome the problem of nesting that is commonly encountered with ordinary saddles. Saddles are also available in ceramic material. We offer these with a glazed construction to enhance capacity and reduce porosity. Super Saddle typically find their application in processes requiring high temperature and chemical attack resistance.



120 (36.6)	SURFACE AREA m ² /m ³ (ft ² /ft ³)	VOIDAGE (%)
Plastic Super Saddles # 1	199 (60.7)	90
Plastic Super Saddles # 2	105 (32.0)	93.3
Plastic Super Saddles # 3	89 (27.1)	94
Ceramic Saddles 1"	255 (77.7)	73
Ceramic Saddles 1.5"	176 (53.6)	74
Ceramic Saddles 2"	120 (36.6)	75

Note :

The above packing are also available in custom sizes from 6mm to 75mm.

RASCHIG RING

Raschig Rings are generic random packing available in metallic, ceramic, graphite and carbon material. It is supplied in many sizes ranging from 5mm to 100mm (1/4" - 4"). Raschig Rings made from carbon or graphite are used in specific applications demanding good corrosion and thermal shock resistance. They are resistant to most acids, alkalis and solvents at high temperatures. They also have high crushing strength and thus, a longer life.



ENGINEERING COMPANIES WE HAVE WORKED WITH:

Air Liquide	Foster Wheeler	MHI
Air Products	GE	Petrofac
Aker Solutions	Haldor-Topsoe	Saipem/Snamprogetti
Black & Veatch	IBI Chematur	Samsung
Chemtex	Jacobs	SNC Lavalin
CTCI	KBR	Technip/FMC
Danieli	L&T	Tecnimont
Descon Engineering	Linde	Thyssenkrupp/UHDE
Engineers India Ltd.	Lurgi	Toyo Engineering
Fluor	Mott MacDonald	WorleyParsons



STRUCTURED PACKINGS

Structured packings are constructed from corrugated & textured metal sheets. The angle of inclination of the corrugations of adjacent sheets is reversed with respect to the vertical column axis, forming mixing cells at every point where the corrugations intersect. The result is a very open honeycomb structure with inclined flow channels giving a relatively high surface area but with very low resistance to gas flow. This structure ensures an excellent and uniform wetting under low and high liquid loads. Column operation at low liquid loads call for specially designed distributors to ensure adequate surface wetting.

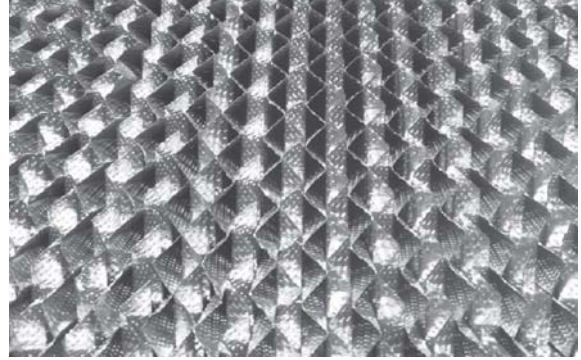

Each subsequent layer of structured packing is rotated 90° so that the sheets of one layer are perpendicular to the sheets of the layer above and below. While passing through each layer, gas and liquid are thoroughly mixed in the direction parallel to the plane of the sheets. By rotating subsequent layers, excellent mixing and spreading, both side-to-side and front-to-back, of fluids are obtained over the entire cross-section of the tower.

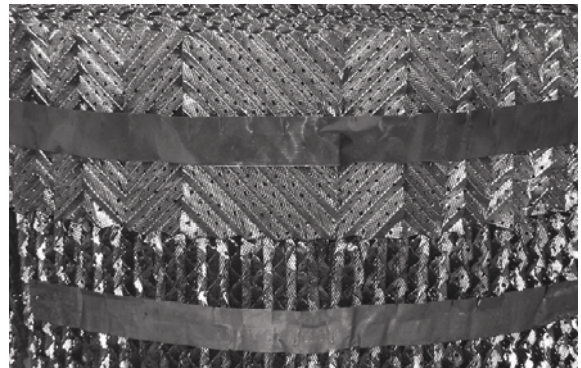

Perforations and surface texturing maximize liquid spreading. These characteristics tend to show significant performance benefits in low pressure and low irrigation rate application.

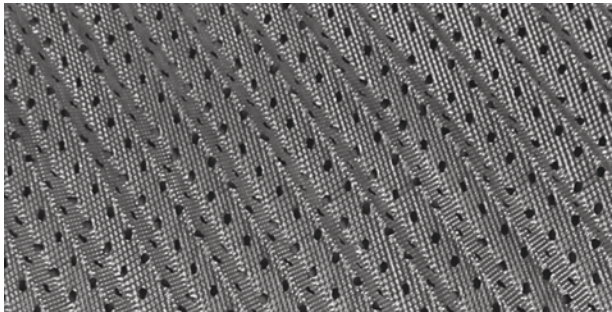

HIGH THROUGHPUT (TYPE "X")

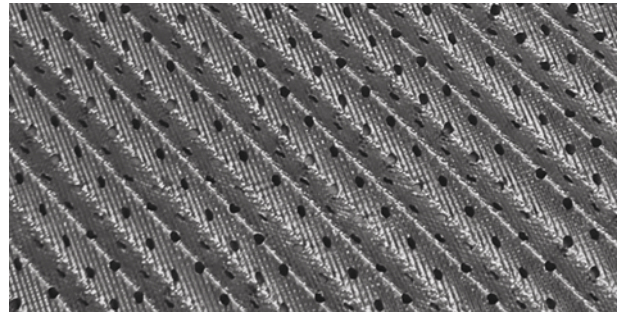

STANDARD (TYPE "Y")

Structured packings are available in two different inclination angles, i.e. Type 'X' and Type 'Y'. The 'Y' type packings have an inclination angle of about 45° from the horizontal axis, and are the most widely used. They provide higher efficiency over their corresponding

'X' counterpart, but at the cost of a higher pressure drop/lower capacity. The 'X' type packings have an inclination angle of 60° from horizontal axis and are used in high capacity and low pressure drop applications.

ME-II SERIES

ME-II Structured Packing, is an efficient and economical structured packing that is widely used in the industry today. ME-II Structured Packing has all the desirable characteristics like predictable throughput, low pressure drop, good efficiency and flexibility; which plays vital role in separations. ME-II Structured packing is available in an array of surface areas (corrugation crimp sizes) & we can also provide intermediate sizes to suit a particular case.



PACKING TYPE	SPECIFIC SURFACE AREA m ² /m ³
ME-II 65 X	65
ME-II 125 X	125
ME-II 170 X	170
ME-II 200 X	210
ME-II 250 X	250
ME-II 350 X	350
ME-II 500 X	500
ME-II 750 X	750

PACKING TYPE	SPECIFIC SURFACE AREA m ² /m ³
ME-II 65 Y	65
ME-II 125 Y	125
ME-II 170 Y	170
ME-II 200 Y	210
ME-II 250 Y	250
ME-II 350 Y	350
ME-II 500 Y	500
ME-II 750 Y	750

VANTAGE SERIES

We also offer the Vantage Series structured packing, a better option, which exceeds the performance of almost all other standard structured packing due to its exceptional liquid-spreading characteristic. Vantage Series structured packing sheets have innumerable fine perforations (pierced but not punched holes) throughout the

surface. This is a distinct advantage over other structured packings that have punched holes resulting in loss of valuable surface area that in turn reduces the potential efficiency of the product.

It is available in same sizes as regular ME-II structured packing.

VANTAGE SERIES structured packing has the added advantage of surface treatment, which is expected to enhance performance.

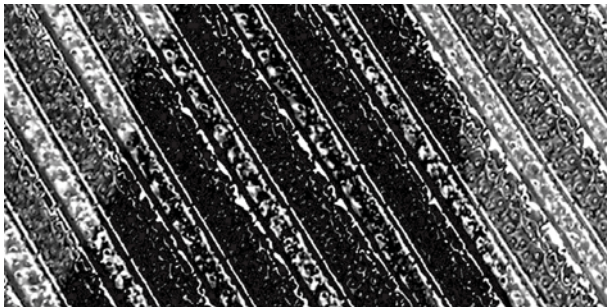

VANTAGE TEXTURE

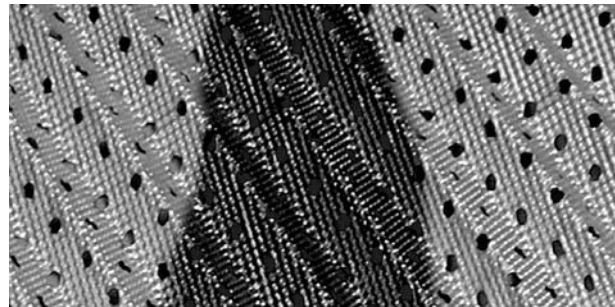

COMPETITOR'S TEXTURE

Vantage Series structured packings are also available in two inclination angles, "X" and "Y".

VANTAGE *ADDITIONAL* SERIES (HIGH CAPACITY)

Our high capacity structured packing belonging to the Vantage Series, has a unique texture to provide an excellent liquid spread & thus lateral distribution.

Owing to it's fluid-dynamic curved shape, our Vantage *Additional* structured packing smoothens the gas passage and minimizes localized hold-up, thus compounding the advantage further.

It reduces the premature flooding at the inter-layer transfer zone. This salient feature provides significant margin at higher loads compared to the traditional product.

The Vantage series is available in the following sizes:

Vantage 200 *Additional*

Vantage 250 *Additional*

Vantage 350 *Additional*

Vantage 450 *Additional*

Vantage 750 *Additional*

Vantage WM BX *Additional*

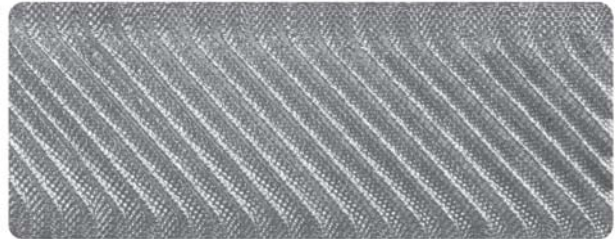
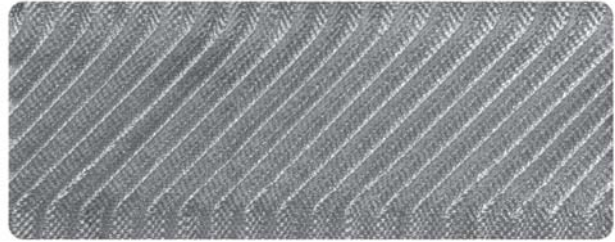

We can also provide intermediate sizes to suit a particular size.

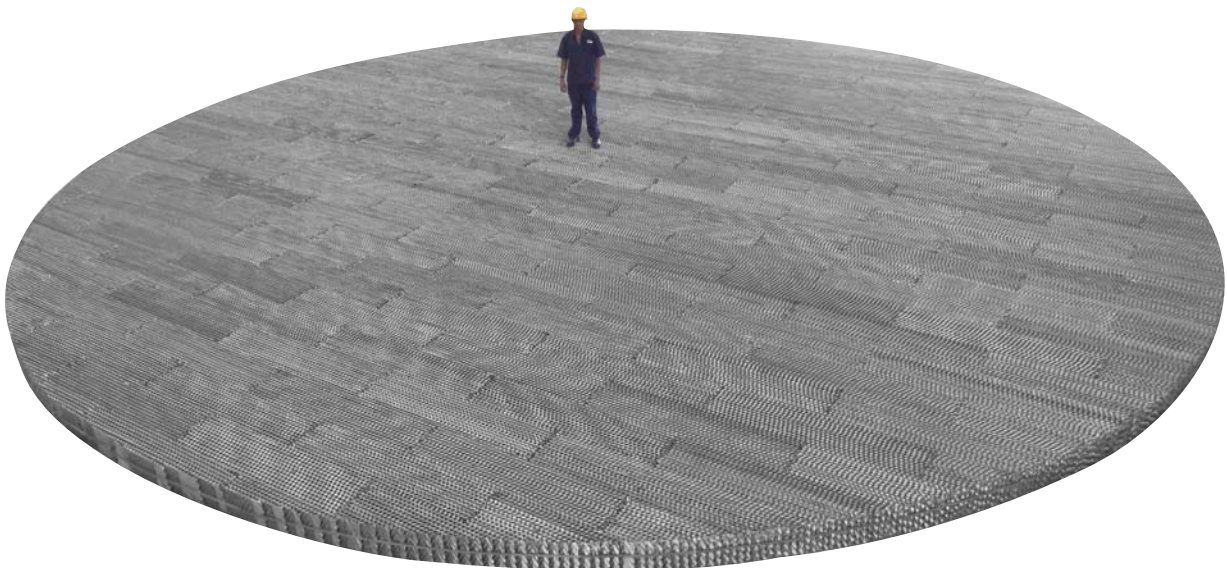

ME-II WIRE MESH SERIES

ME-II Wire Mesh Packing has enhanced self-wetting characteristics; as the fiber is woven from fine diameter wires. The packing element consists of parallel-perforated corrugated sheets of wire mesh.

These packings are particularly suited in separations that require a large number of separation stages, which typically operate under

high vacuum and therefore low liquid loads. The capillary action of the wire mesh ensures complete surface wetting & hence provides a low HETP. Typically 5 to 10 number of theoretical stages per meter of packed height can be achieved with this packing when complemented with high efficiency internals.

ME-II Wire Mesh Packing is available in following two types

ME-II WIRE MESH BX - 500 m²/m³ specific surface area

ME-II WIRE MESH CY - 750 m²/m³ specific surface area



Characteristics:

High separation efficiency almost upto capacity limits

- High throughput
- Low pressure drop
- Liquid loads as low as approximately 0.1 m³/m².hr
- Can be adapted to any fractionating task by variable specific surface.

GRID PACKING SERIES

Grid Packing are recommended for applications with fouling, coking and solid contents.

The Grid Packing has robust mechanical structure, fabricated in modules for ease of installation and cleaning.

The Grid Packing offers minimum pressure drop & higher capacity.

- Specific Surface Area from 40-90 m²/m³
- Material thickness 0.5 to 2 mm

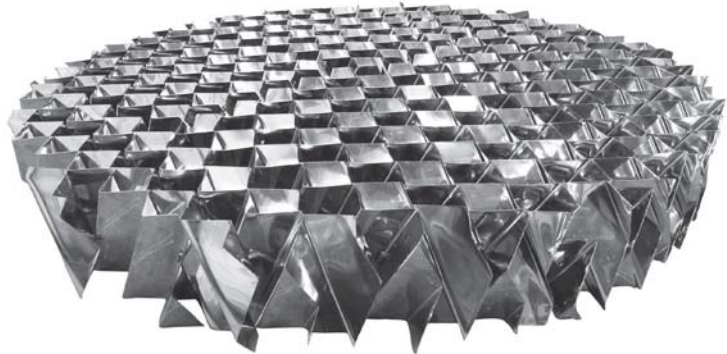

TOWER INTERNALS

LIQUID DISTRIBUTIONS

IMPORTANCE OF LIQUID DISTRIBUTION

Packed tower design is based on the fundamental concept of equal liquid and gas superficial velocity across the column section. The pressure drop across the packing provides an impetus for the upward flowing gas to become uniformly distributed across the column area. The liquid flows down the packed bed by gravity and unlike a gas, the liquid has poorer cross-mixing tendencies. It is therefore imperative to manage and ensure very uniform liquid distribution at the top of the bed. Distributors are internals installed above a packed bed, which perform the job of providing a finite liquid distribution over the packed bed. A distributor allows liquid to be distributed over the packed bed in discrete streams. This can be done either through orifices or V-weirs located on/in the distributor. Distributors also provide a separate passage for the upward flowing gas.

Once liquid enters the packed bed, the packing tends to redistribute the liquid by virtue of dispersion and after some height, the liquid profile adapts to the natural distribution tendency of the packings, which generally, is worse than the initial liquid distribution provided by the distributor. Because of this, liquid distribution in packed beds tends to break down after fixed heights and liquid redistributors are provided to collect all the downward flowing liquid and redirect it uniformly into next packed bed.

A packed bed irrigated by a very good distributor allows one to realize the full separation potential (Number of stages) of the packed bed.

Distribution Quality:

Quantifying the uniformity of liquid distribution is done by calculating the distribution quality (DQ) of a distributor. It relates the liquid flux across the column area at the top of the packed bed by marking circles proportional to the liquid flow through a particular orifice and then considering the irrigated, overlapping and un-irrigated areas of the circles. An ideal distributor should have a DQ of 100%, but practical considerations restrict the DQ to about 95% maximum. A low DQ indicates a high degree of maldistribution and some portions of the column cross sectional area may be receiving substantially different volumes of liquid when compared to other portions of cross-sectional area. In large diameter columns, proper irrigation of areas near the column wall becomes a very crucial factor in maintaining a good DQ.

A distributor with a very good DQ (85-95%) helps to exploit the full separation efficiency of a packed bed. As the DQ decreases the number of stages that can be realized from the packed bed decreases, thus decreasing the separation efficiency.

Various factors to consider in the design of liquid distributors/re-distributors are:

1. Point count :

This indicates the number of irrigation points provided per square meter (foot) of the column area and is primarily a function of packing size, the liquid load and the desired DQ. Smaller, highly efficient packings (that provide a very low HETP), require a larger number of drip points and vice-versa.

2. Hydraulic Design :

This is the most important aspect of the distributor design wherein the designer determines the various dimensional details of the distributor to ensure its efficiency over the desired range of working conditions.

A distributor can feed the liquid to the packing top either under pressure, as in a pressure feed distributor, or by gravity, as in a gravity flow distributor, where the liquid falls through the distributor by virtue of the liquid head on the distributor deck.

Pressure feed distributors can be categorized as either ladder arm type or of spray nozzle type distributors. These distributors are used for very specific applications, such as, heat transfer services. Because these distributors operate under pressure, the orifice sizes in these distributors are usually small. Pressure feed distributors should not be used with flashing feed. The major advantage of using a pressure feed distributor is total wetting of the surface of the packed bed. High point to point flow variation and high cost are some of the disadvantages to these type of distributors.

Unless otherwise requested we always recommend a gravity flow distributor. These distributors offer excellent uniformity and control of liquid flow to the packed bed. A gravity feed distributor can utilize either orifices or V-Weirs to feed the liquid. The orifices can be located on the floor of the deck/trough or on the side wall of a trough (single level or multilevel). Passage for gas rising upwards is either provided by riser boxes/pipes or through the gaps between the troughs.

Orifices are sized to maintain a minimum liquid head at desired turn down conditions and to avoid distributor flooding/overflow during turn up conditions (maximum desired flow rates). Very small orifice diameters are avoided to prevent fouling. Distributor levelness, liquid gradient due to cross flow, aeration of the liquid from falling liquid streams, and the ledge/support ring levelness are considered during the orifice sizing, so that even at very low flows, the orifice to orifice flow variation is maintained in acceptable limits.

For highly fouling services, which can occur in processes with high level of sediments in the feed stream, coking, debris, polymerization etc., orifices on the deck floor are avoided. Depending on the service, V-weirs or orifices on the side wall are recommended.

Multilevel ori?ces help in the distributor operation over a wide range of ?ows and are typically used whenever a very high turn-up/turn down range is required.

3. Distribution Quality (DQ) :

The drip points are laid out to meet speci?ed drip point requirements. Design considerations for Distribution Quality include: the service and separation e?iciency required from packed bed and packing size. During this stage of the distributor design, allowances are made for the distributor construction details such as support beams, gas risers etc., so as to obtain the required DQ for a particular distributor.

Major factors guiding selection of Distributor Model:

- Tower size and mechanical constraints
- Type of service
- Turn down ratio/operating range
- Type and size of packing
- Vapor/Gas pressure drop requirements
- Riser layout to control the liquid cross ?ow velocity across the deck and vapor distribution across the Distributor.
- Available method of attaching the Distributor to the column.



PAN TYPE DISTRIBUTOR/REDISTRIBUTOR (MODEL DPC501/RPC502)

This simple looking device for small towers is actually a high performance distributor consisting of critically sized ori?ces, uniformly laid out on the base of the pan for proper liquid down ?ow, and adequate open area for upward ?ow of vapor.

This distributor can be made in both single and multi-piece construction. In multi-piece construction, all joints are gasketed.

Attachment to the tower wall is usually achieved by bolting to tower attachment clips. It can also be sandwiched between body ?anges. Alternatively, it can be suspended from a ring, sandwiched between the body ?anges. Mounting methods for the distributor will depend upon the location of other internals and in case of revamps, the type of attachments already present in the column.

A Redistributor employs riser caps and when the attachment is to clips, a wall wiper is also required.

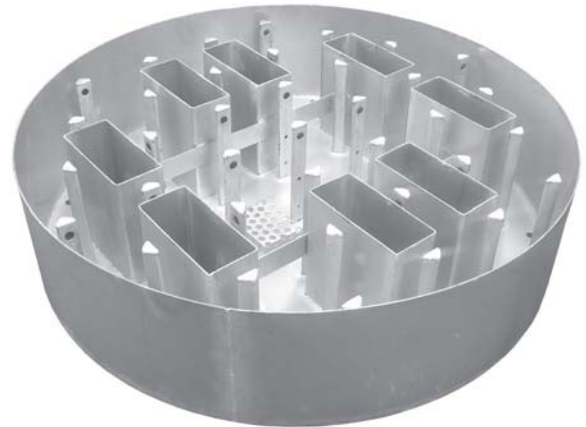

Selection criteria*:

- Column diameter between 150-900 mm (6-36 inches)
- Maximum Turndown ratio 2:1
- Liquid rates $> 5 \text{ m}^3/\text{m}^2.\text{hr}$ (2.0 GPM/ft²)
- Low fouling

RISER DECK DISTRIBUTOR/REDISTRIBUTOR (MODEL DRD503/RRD504)

The Riser Deck Distributor is a deck type distributor where ori?ces are located on the base/deck of the distributor. Gas risers located between the ori?ces propagate liquid cross-?ow, thereby enhancing distribution quality.

This style of distributor is generally supplied in multi-piece construction and all joints are sealed with gaskets. Attachment is by clamping to a ledge/support ring that is welded to column wall. This distributor can be provided with anti-migration bars in the risers to eliminate the requirement for a bed limiter. Redistributor risers are capped to prevent bypassing of liquid through risers from liquid raining down from the packed bed above.

Selection criteria*:

- Column diameter $> 600 \text{ mm}$ (24 inches)
- Maximum Turndown ratio 2:1
- Liquid rates $> 5 \text{ m}^3/\text{m}^2.\text{hr}$ (2.0 GPM/ft²)
- Low fouling



TROUGH TYPE DISTRIBUTOR WITH PARTING BOX (MODEL DTP505)

The Trough Style Distributor consists of long tunnels called troughs, and one or more parting boxes, for feeding liquid to the troughs. The parting box helps in controlling the feed velocity to the troughs and ensures proportional distribution of the liquid. The space between the troughs is available for vapor passage. Number and location of the parting boxes will depend on the column diameter. Orifices can be located either on the wall or on the base of the troughs. When orifices are located on the wall, conductor tubes are provided at the wall to guide the flow of liquid.

The Trough Style Distributor usually rests on a ledge/support ring. It can also be suspended from beams. The advantage of parting box is the absence of joints, thus providing excellent liquid seal. Redistributors are not available in this model.



Selection criteria*:

- Column diameter > 250 mm (10 inches)
- Maximum Turndown ratio 10:1
- Liquid rates between 2-30 m³/m².hr (0.5-12.25 GPM/ft²)
- Low to medium fouling

TROUGH TYPE DISTRIBUTOR/REDISTRIBUTOR WITH SUMP (MODEL DTS506/RTS507)

This distributor is similar to Model DTP505 except for the parting box, which is replaced by a sump. Feed enters the sump, which divides it proportionately to the troughs. Orifice for liquid can be located either on the base or on the wall of the troughs. Distribution points are also located at the centerline of the distributor by providing tubes in the center of the sump.

Achieving adequate sealing is critical because of the large number of joints at the sump to trough connection. All joints are gasketed for adequate sealing.

This distributor rests on a ledge/support ring. The redistributor includes riser caps and a wall wiper.



Selection criteria*:

- Column diameter > 250 mm (10 inches)
- Maximum Turndown ratio 10:1
- Liquid rates between 2-30 m³/m².hr (0.5-12.25 GPM/ft²)
- Low to medium fouling

TROUGH TYPE DISTRIBUTOR/REDISTRIBUTOR WITH END CLOSURE (MODEL DTE508/RTE509)

This style Distributor consists of long risers that are made from the deck itself, giving it a trough type look with end closure plates for liquid balancing between the troughs. The ori?ces are laid either

in square pitch or triangular pitch on the deck. This distributor is clamped to a ledge/support ring.

Selection criteria*:

- Column diameter > 300 mm (12 inches)
- Maximum Turndown ratio 2.5:1
- Liquid rates between 2.0-120 m³/m².hr (0.8-50 GPM/ft²)
- Low fouling tendency



FLOW MULTIPLIER DISTRIBUTOR/REDISTRIBUTOR (MODEL DFM510/RFM511)

This type of Distributor is primarily used in very low liquid flow. Flow multipliers are used below each ori?ce to increase the drip point density. Construction is similar to the Riser Deck Distributor/Trough type Distributor except that the ori?ces are located on the wall of the

tubes instead of the deck. Tubes are welded to and extend below the deck. At the end of the tubes, liquid is divided into three or more streams by means of flow point multipliers. This distributor is clamped on a ledge/support ring.

Selection criteria*:

- Column diameter > 250 mm (10 inches)
- Maximum Turndown ratio 3:1
- Liquid rates < 30 m³/m².hr (12.25 GPM/ft²)
- Medium fouling



V-WEIR DISTRIBUTOR (MODEL DWV512/RVW 515)

V-Weir distributors are used when the fouling tendency of the system is high. A wide turn down range is possible due to the weirs, which permit greater flow rates as liquid head increases. With this style distributor, the liquid & the gas share the same flow area. The gas velocity through the risers usually limits the maximum flow rate of this style distributor. These distributors provide low quality of distribution compared to other distributors.

V-Weir distributors are made either in pan construction (for small columns) or deck/trough construction (for larger columns). This style distributor is clamped to or is rested on a ledge/support ring.

Selection criteria*:

- Column diameter >250 mm (10 inches)
- Maximum Turndown ratio 20:1
- Liquid rates between 2.5-100 m³/m².hr (1-40 GPM/ft²)
- High fouling

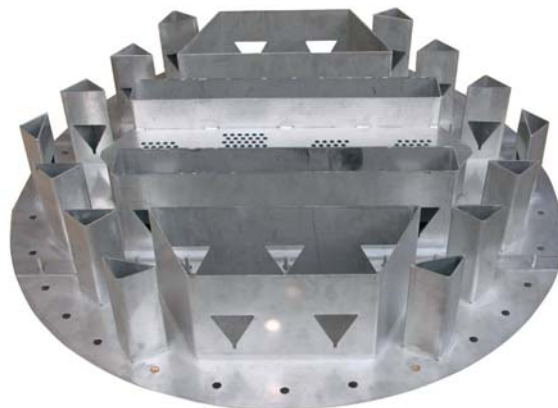

SPRAY NOZZLE DISTRIBUTOR (MODEL DSN513)

As the name indicates, this style distributor consists of spray nozzles arranged on pipe assembly. It is generally used for shallow beds in heat transfer applications, in scrubbing services, and applications where a large vapor handling capacity is most important. It can also handle low liquid flow rates.

The quality of distribution is somewhat inferior compared to orifice type distributors because the spray cones create areas of uneven irrigation and a significant amount of liquid is directed towards the tower wall. The main header is angled at one end and clamped to a column wall clip at the opposite end. Depending on the column diameter, the individual laterals may also be clamped to column wall clips.

Selection criteria*:

- Column diameter >250 mm (10 inches)
- Maximum Turn-down ratio 3:1
- Liquid rates: 0.5-120 m³/m².hr (0.2-50 GPM/ft²)
- Clean service

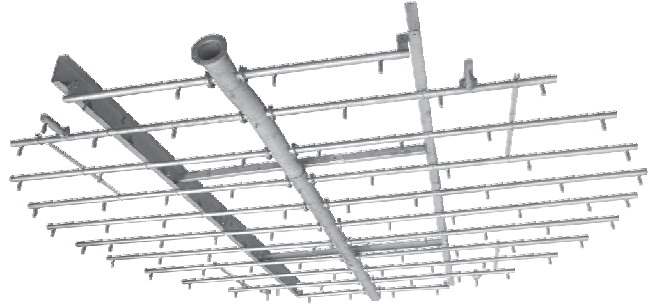

PIPE ARM DISTRIBUTOR (MODEL DPA514)

This is a very simple distributor consisting of a header and lateral assembly. It requires very little column height and provides high open area resulting in very low pressure drop. It does not provide very high distribution quality, and thus, finds limited applications. The main

header is angled at one end and clamped to a column wall clip at the opposite end.

Selection criteria*:

- Column diameter >250 mm (10 inches)
- Maximum Turn-down ratio 3:1
- Liquid rates: 4.0-25 m³/m².hr (1.0-10.25 GPM/ft²)
- Clean service

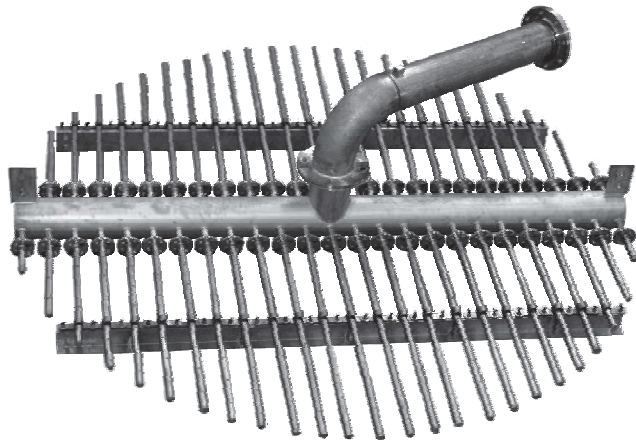

* General Note on Selection Criteria :

Selection criteria guidelines given in the brochure are typical but not limiting. Under certain conditions special design provisions can be made for accommodating varied hydraulic & mechanical requirements.

These are custom made equipment. Photos given are for representative purpose only.

VAPOR DISTRIBUTIONS

IMPORTANCE OF VAPOR DISTRIBUTION

To get the optimum Mass Transfer in the packed bed not only the distribution of liquid but of gas also is important. The significant role of Liquid Distributors is generally well understood, while the importance of Vapor/Gas Distributors requires more emphasis. There are various types of Gas Distributors viz:

VAPOR FEED DISTRIBUTOR (MODEL VFD546)

The model 546 pipe arm Vapor Distributor is used when a Vapor Feed requires uniform distribution over the tower area to ensure a uniform mix with the existing column vapor and to minimize the possibility of liquid/vapor channeling through packed beds. Typical applications include introduction of a vapor feed into the column or introduction of vapor into the bottom of larger diameter columns.

This distributor would be supported using an internal pipe hanger and/or wall clips.



VAPOR DISTRIBUTOR PLATE (MODEL VDP547)

The model 547 Vapor Distributor Plate is used when vapor enters the bottom of a column with a very high kinetic energy. This distributor will consume some pressure drop in the vapor, reduce its kinetic energy, and ensure good distribution below the packed bed. The pressure drop across this distributor can be anywhere between 100-1000 Pa (0.015 - 0.145 psi).

The model 547 is available in any weldable sheet metal, is gasketed, and is supported by a ledge/ support ring. Mid-span support beams may be required in large columns. This distributor is supplied with liquid downpipes or a sump for removal of the liquid.



VAPOR INLET DEVICE (MODEL VID808)

VID 808 is generally required whenever a very high-velocity or unevenly distributed vapor flow is anticipated. The purpose of VID is to decrease the momentum of the vapor feed and evenly distribute the gas across the vessel cross section. The same is obtained by dividing the feed mixture into horizontal streams. This reduces the vertical vapor velocity within a short distance of its discharge into the tower.

Typically it is located in the bottom section of the column where reboiler feed is entering the tower or between the tray and packing section. Kinetic energy of the inlet vapor and the vapor fraction, these two factors, must be considered while designing these devices.

The installation is generally in horizontal inlets in vertical column.



FEED DEVICES

Processes demand various feeds to be introduced into the column at appropriate locations. The feeds being introduced could be:

- Liquid only
- Liquid & vapor above a packed bed (flashing or suppressed flash) or between the trays
- Vapor only below a packed bed
- Reboiler returns

Liquid-only feed devices are required to introduce liquid into the column, either as feed or as reflux. The liquid is fed into/onto the distributor and its design depends on the distributor type, liquid flow, operation range, degree of sub-cooling, etc.

For liquid and vapor feed devices above a distributor, separating the two phases is of primary importance. The primary design factors are the feed flow rate, the type of

flow at feed (flashing or suppressed), desired turndown, column height needed for flashing vapor distribution, and mixing of the inlet liquid with overhead liquid.

Vapor only feed devices are required for reboiler returns or to introduce vapor feed, or gaseous feeds. If the column offers adequate pressure drop, the packings themselves tend to mix the vapors. In event of very low pressure drop across the packed beds, vapor channeling can become a serious problem. The kinetic energy of the vapor and its composition at the point of introduction are the two main factors considered in designing the vapor entry device.

LIQUID FEED PIPE (MODEL LFP541/LFP542)

The model 541 feed pipe is a piping system of headers, lateral branches and down pipes, and is used when liquid is fed from outside the column onto a distributor/redistributor. Each feed pipe meters flow to one or more appropriate feed areas, matching the hydraulic requirements of the distributor to prevent excessive turbulence and control the horizontal flow velocity in the distributor.

The model LFP542 feed system employs a feed pipe which feeds a parting box or a calming box, which in turn feeds a distributor. It can operate over a wider range of flow rates as compared to the model LFP 541, but it may require slightly more tower height.

The model LFP 541/542 is attached to an internal column angle and/or by tower wall clips.

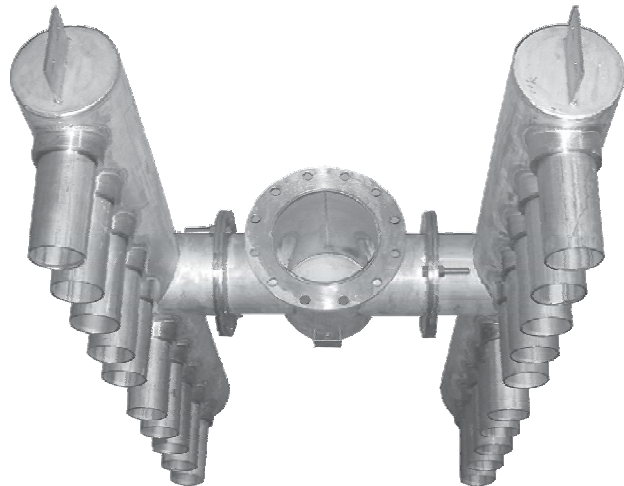

FLASH FEED GALLERY (MODEL FFG543)

The model 543 Flash Feed Gallery is a two phase feed device fed by a tangential inlet tower nozzle or a radial nozzle with a flow deflector. A gallery below provides the residence time necessary to disengage the gas and the liquid. Liquid is then fed to a distributor or into pre-distributor (parting box). This model is recommended in towers > 900mm (36 inches) ID. It is capable of handling any liquid to vapor feed ratio.

The inside of gallery may be round or polygonal. The gallery is clamped to a ledge/support ring. Our Flash Feed Galleries are typically seal welded after installation but fully gasketed construction is also available.

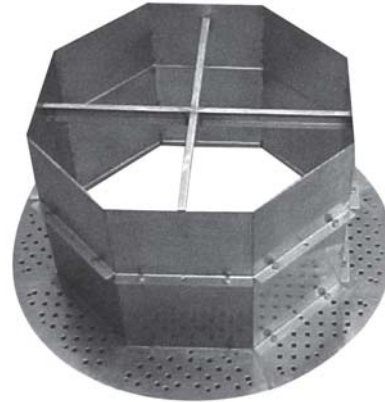

FLASH FEED CHAMBER (MODEL FFC544)

The model 544 Flash Feed Chamber is a two phase feed device used in small columns, typically < 1200 mm (48 inches) ID. The feed enters through a radial inlet and is centrifuged in the chamber with the vapors coming out of the top. Disengaged liquid is fed from the bottom of the Flashing Feed Chamber to a distributor/pre-distributor below.

For towers between 250-530mm (10-20 inches) ID, the model 544 is constructed in one piece; multi-piece construction is used for larger towers.

The model can be attached to an internal column flange and further supported by the tower wall clips.

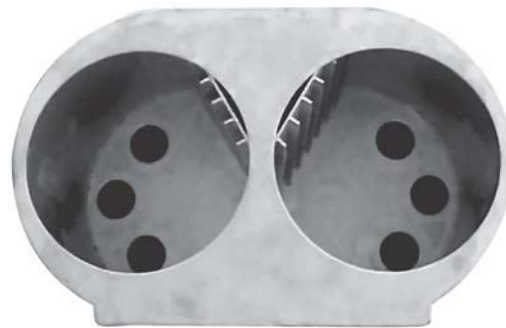

FLASHING FEED PIPE (MODEL FFP545)

The model 545 Flashing Feed Pipe is used to separate two phase feed when the inlet flow is in a separated flow region. Here, the two-phase flow enters center pipe, the vapors are released from the upper area of the pipe, and the liquid flows to the outer chamber where it is fed to the distributor/pre-distributor below.

The compact design of this model makes good use of available tower height.

The model 545 is connected to an internal tower flange and is commonly supported by a tower wall clip. This device is constructed in one piece, provided access diameter is sufficient. Alternatively, multi-piece construction with gasketing can be supplied.



COLLECTORS/CHIMNEY TRAYS

Liquid collection between packed beds and trays is frequently required. Liquid collectors are used in three main applications:

- For total draw-off of liquid as a product, to provide the feed to a reboiler, or for pump-around sections
- Partial draw-off of liquid with overflow of the remaining liquid continuing down the tower
- Collection of liquid for mixing

Collector trays come in different design styles to meet the needs of specific applications. Factors considered in the design of collector trays include:

- Height required/available for the collector tray
- Column pressure (Vacuum) and permissible pressure drop (to determine the required open area)
- Liquid and vapor loads and densities
- Column diameter
- Liquid draw-off quantity
- Residence time

LIQUID COLLECTOR TRAY (MODEL LCT551)

This deck type liquid collector is versatile and can be used in all towers. Liquid volume and residence time are controlled by utilizing tall risers on the tray deck. Sumps can be added on one side, both sides, or across the center to facilitate liquid withdrawal. This collector can provide 25 to 40% open area. Mid-span support beams are required in large columns > 2000mm (78 inches) ID.

The deck and optional sump(s) rest on a ledge/tray support ring and the plate can be seal-welded. Gas risers can be made in sections/pieces to allow installation through a manhole where they can be subsequently welded to the seal welded deck.



VANE COLLECTOR TRAY (MODEL VCT552)

The model 552 is used in towers that process high vapor loads and low liquid loads (vacuum service). The vane blades collect the overhead liquid and direct it into an annular sump, which may then be drawn from the tower or fed to a distributor below using an appropriate feeding system. It offers minimal pressure drop and it can provide open areas from 40-75%. It also minimizes entrainment, even at high vapor rates as is common with traditional gas risers in this type of service.

The vanes rest on an annular sump, and are fastened to clips provided on the sump. The sump is welded to tower wall and is generally supplied by the column vendor as a tower attachment. For larger towers and high liquid rates, one or more collection troughs are added, spanning across the annular sump to reduce liquid gradients.



SUPPORT PLATES

Support plates are provided to physically support the cumulative weight of the random/structured packings and the operating “liquid hold-up” in the packed bed. Support plates are shaped and designed to provide maximum open area and minimal pressure drop. Factors that influence the choice and design of the support plate include the column diameter, design loads (mechanical and hydraulic), packing type, liquid hold up, and system corrosivity.

Gas injection support plates used extensively in random packed beds, provide separate pathways for gas and liquid, thus reducing pressure drop across the support

plate. These are the preferred type of random packing support plate and are used in majority of process applications. An available light duty support plate is used only for very small columns and where mechanical and hydraulic loading is not severe.

All support plates rest directly on a ledge/support ring since the weight of the packing is usually sufficient to keep the support plate in place. If required however, they can be clamped to the support ring. This is typically done for services where pressure surges may dislodge a packed bed. We can supply support plates in metal or thermo plastic materials.

SUPPORT PLATE (MODEL SPL521)

Model SPL521 is a gas injection type support plate designed for random packed beds in towers generally greater than 900 mm (36 inches) diameter. It is designed for higher mechanical strength. The beams are made in single units that pass through a manhole. Special variants of this support plate are available to handle very tall beds. The model SPL521 Gas Injection Support Plate is also available in most metals and in thermo plastic materials.

Very tall beds together with larger column diameters result in higher mechanical loads. In such cases, support plates are supported using I-beams in conjunction with a tray support ring.

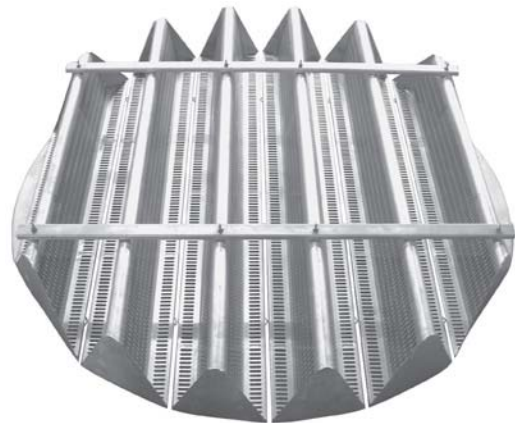

SUPPORT PLATE (MODEL SPM522)

Model SPM522 is a gas injection type support plate designed for towers generally smaller than 900mm (36 inches) diameter. This type of support plate is designed in multi-piece or single piece construction depending upon whether the support plate will be installed through a column manway or through a column body flange. The slot size is based on the size of packing to be supported. These support plates rest freely on a ledge/support ring or can be bolted/clamped directly to a tray support ring.

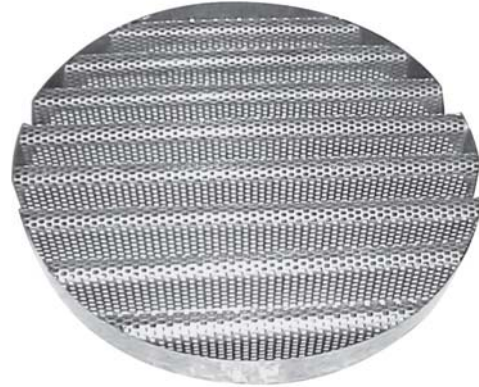

SUPPORT PLATE (MODEL SPS523)

Model SPS523 is a support plate recommended for towers generally smaller than 900mm (36 inches) diameter. This type of support plate is designed using expanded metal and is constructed as a multi-piece or single piece unit depending on the column opening that will be available to install it. These support plates rest freely on, or can be clamped/bolted to, a ledge support ring.



SUPPORT GRID (MODEL SGS524)

Model SGS524 is a support grid used in towers for supporting structured packing. It is designed to allow free passage of gas and liquid. These support plates rest freely or can be clamped to a ledge/support ring.

Very tall beds together with larger column diameters result in higher mechanical loads. In such cases, support grids are supported using I-beams in conjunction with a tray support ring.



BED LIMITERS

Bed limiters and hold down plates are retaining devices used above packed beds to prevent fluidization and restrict packing movement, which can occur during upset conditions. Bed limiters are used for metal and plastic random packings as well as structured packings. They are fastened to the column wall by means of a support ring or bolting clips. They can also be suspended on tie rods from the liquid distributor.

Hold down plates are used for ceramic and carbon packings. They rest directly on packings and prevent packings from breaking up due to fluidization when operated at high pressure drops or during temporary surges.

In place of bed limiters, anti migration bars may also be used at the bottom of the gas risers of a distributor. They do not prevent fluidization of the bed but prevent the random packing elements from being blown up through the gas risers.

Bed limiters are designed to provide high open-area and reduce interference to liquid flow. They should be designed to withstand upward forces acting on the packed bed.

BED LIMITER FOR RANDOM PACKING (MODEL BLR531)

This bed limiter is normally recommended for metal and plastic random packings. It is designed to withstand an upward thrust. The opening size can be varied to suit various packing sizes and the beams can be designed to support a prescribed man-load. The normal bed limiter is clamped on to a ledge/support ring.

In cases where the bed limiter may be located below a high performance distributor, the bed limiter construction can be made expandable, with jack screws provided to tighten on the column wall. This eliminates the need for a ledge/support ring and maintains good distribution near the column wall.



BED LIMITER FOR STRUCTURED PACKING/HOLD DOWN GRID (MODEL BLS532)

This bed limiter is normally recommended for towers using structured packings. Fluidization does not occur with structured packings, but for large diameter columns, sections of packings may be dislodged during upset conditions. Bed limiters for structured packings are designed to reduce interference with liquid distribution. They are bolted to the column wall by vertical clips. For smaller columns, the distributor is provided with an integral retention plate, thereby eliminating need for separate bed limiter.



HOLD DOWN PLATE (MODEL HDP533)

Hold down plates rest directly on the tower packings and are normally recommended for ceramic & carbon random packings or where no tray support rings is available. The opening sizes can be varied to suit various packing sizes & the beams can be designed to support a prescribed man-load. The major advantage of using this type of movable, anti-migration screen is to reduce the crushing of tower packing during surges or bed expansions. Hold down plates are held in place by providing weight bars and do not require any type of clamping arrangement.



INTERNALS FOR LIQUID - LIQUID EXTRACTION

Packing is used in counter-current liquid/liquid contactors to facilitate mass transfer. The heavier phase is introduced from the top, flows downward and exits the column at the bottom. The lighter phase on the other hand, enters at the bottom and exits the column at the top. Depending on the process, one of the liquids is the continuous phase and the other is dispersed phase. Special internals are used to introduce the two liquid phases, especially the dispersed phase. Selection & arrangement of the internals depends on which phase (light or heavy) is continuous and which is dispersed. In all cases, the use of feed pipes for directing the feed, light and heavy, to the disperser are recommended to control velocity.

In contactors where the light phase, feed which enters the bottom of the tower, is dispersed, packed beds are supported by the model 561 disperser support plate. In addition to supporting the packing, the plates allow proper dispersion or formation of small droplets that rise through the continuous phase. In breaking the dispersed liquid into small droplets, the model 561 provides maximum initial contact area between the two phases. Because the droplets tend to coalesce in the packing, beds are typically limited to a depth of 6 to 8 ft (1.5 to 2.5m). Multiple beds, each supported by a model 561

are recommended where a total of more than 8ft (2.5m) of packing is required.

When the heavy phase, feed which enters the top of the tower, is dispersed, the model 562 disperser plate is used above the top bed. When multiple beds are required, the model 562 is also used to support the upper beds, collect, and disperse the heavy phase to the beds below. The bottom bed is supported by conventional support plate (see models SPL521 or SPM522). The model 562, although structurally different, is hydraulically inverted when compared to the model 561. In heavy phase dispersed contactors, the same bed depth recommendations apply as with light-phase dispersion.

It is generally recommended to disperse the phase with the higher flow rate to generate maximum interfacial contact. The exception to this rule is when the higher volumetric flow rate phase has higher viscosity or preferentially wets the packing surface.

Surfactants may alter surface properties to the extent that the performance of a liquid - liquid contactor cannot be predicted.

LIGHT PHASE DISPERSER (MODEL LLE561-LP)

A special feed pipe arrangement (Model LFP 563), which ensures no flow of the lighter dispersed phase through the heavier continuous phase downcomer tubes, is recommended to feed the dispersed phase to the model LLE 561-LP. Similarly a special feed pipe (Model LFP 564) is also provided for the entry of the continuous heavier phase at the top of bed.

This plate is supported by a full ledge/support ring and is designed to support the packings. Tube restrictors of different sizes are used to prevent the packing from falling through the heavier phase downpipes.

This model is used when the lighter phase is dispersed (the heavier phase is continuous) and therefore, must be located at the bottom of the packed bed. It serves the twin purposes of a disperser and a support plate. Downcomer tubes allow the heavy phase to travel downward through the plate. The light phase forms a pool or a coalesced layer under the plate and orifices generate droplets. The plate design depends on interfacial surface tension, viscosity and differential densities. This plate also acts as a re-disperser and a support plate in multi-bed towers.



HEAVY PHASE DISPERSER (MODEL LLE562-HP)

This model is used when the heavier phase is dispersed (the lighter phase is continuous) and hence is located at the top of the packed bed. It serves the purpose of only a disperser plate and a standard packing support plate has to be used to support the packed bed. Riser tubes allow the light phase to travel upward through the plate. The heavy phase forms a pool or a coalesced layer above the plate and ori?ces generate droplets. The plate design depends on interfacial surface tension, viscosity and di?erential densities. Re-disperser plates are provided in multi-bed towers.

A special feed pipe arrangement (Model LFP 563), which ensures no ?ow of dispersed heavy phase through the light phase riser tubes, is recommended to feed the disperser. A special feed pipe (Model LLE 564) is also recommended for the entry of the continuous lighter phase at the bottom of the bed.

This plate is supported by a full ledge/support ring. Tube restrictors of di?erent sizes are used to prevent the packing from passing upward through the riser pipes for the lighter phase.

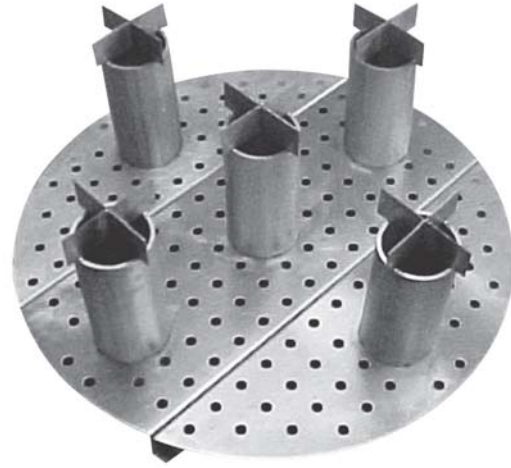

PLASTIC INTERNALS

We supply tower internals (i.e. bed limiters, distributors, support plates, etc.) out of FRP and its composites, with thermoplastic liners such as PP, PVC, CPVC etc. These internals are designed to provide optimum performance and operating conditions. Major advantages of plastic internals are their lightweight construction and chemical resistance.

We can also provide engineered (hydraulic and mechanical) design for packed tower internals (i.e. packing supports, bed limiters, various types of distributors and collector trays, liquid and vapor feed inlet devices etc) fabricated from non-metallic materials. These internals can be supplied up-to a column diameter of 7000 mm (23 feet). We can also review the column drawings and tower attachments required for non-metallic internals.

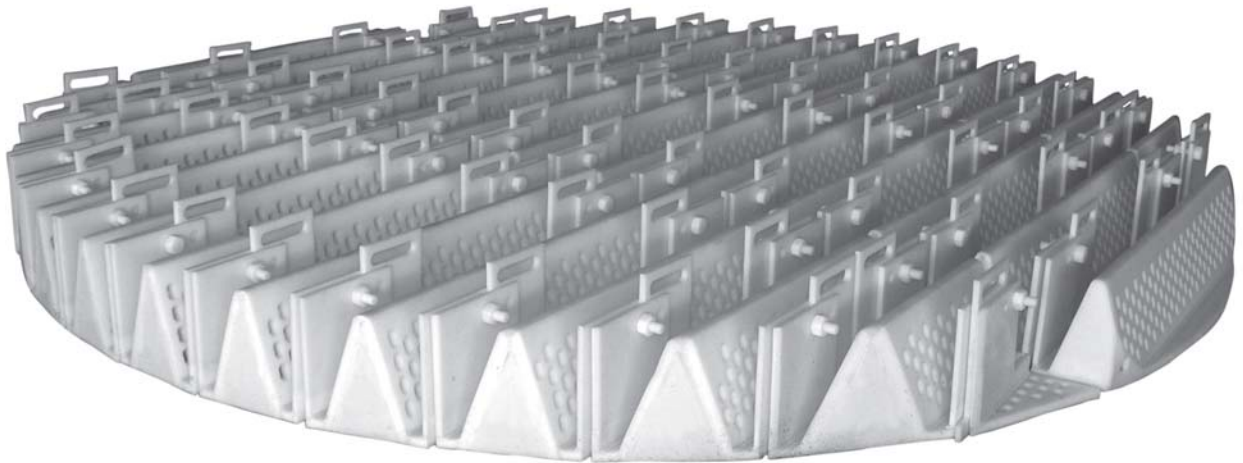

MIST ELIMINATORS

Mist elimination, or the removal of entrained liquid droplets from a vapor stream, is one of the most commonly encountered processes of unit operation. Droplets are removed from a vapor stream through a regardless series of three stages: collision & adherence to a target, coalescence into larger droplets, and drainage from the impingement element.

TYPICAL SIZE RANGE OF MIST DROPLETS CREATED BY VARIOUS PROCESS (MICRONS)

Mechanical

Column packing or trays	5 to 800 μm
Sprays	10 to 1,000 μm
Surface evaporation	3 to 1,000 μm

Chemical

Acid mists	0.1 to 15 μm
------------	-------------------------

Condensation

Blown o^2 heat exchanger surface	3 to 500 μm
In saturated vapor	0.1 to 50 μm



WIN MESH-TYPE

WIN - Mesh Type Mist Eliminators consist of a pad of knitted wire mesh usually sandwiched between grids for mechanical support. Except for units less than about 600mm diameter, they are normally split into sections of between 300 to 400 mm wide to facilitate installation through a vessel man way. The pads are cut slightly oversize to ensure a snug fit and thus eliminate any possible vapor

by-pass either between sections or between pad and vessel wall.

Each mesh pad is formed from crimped layers of knitted fabric with the direction of the crimp rotated 90° in each adjacent layer to provide a uniform voidage together with a high ratio of ϕ lament surface per unit volume of pad.

Specifications:

WIN - Mesh Type Mist Eliminators are manufactured in a variety of materials. The list of WIN standard mesh styles is illustrated herewith: HE - High Efficiency removal of fine mists, GP - General Purpose, DS - Dirty Service where fouling is an issue, HC-High Capacity

WIN - Mesh Type Mist Eliminator Styles:

STYLE	SPECIFICATIONS (FOR SS MATERIALS)		
	BULK DENSITY (Kg/m ³)	SURFACE AREA (m ² /m ³)	FREE VOLUME (PERCENTAGE)
HE-CBA	192	640	97.6
HE	144	480	98.2
HE-CBF	115	383	98.6
GP-DBA	192	350	97.6
GP	173	315	97.8
GP-DCA	144	262	98.2
DS	112	204	98.6
DS-ICA	80	145	99.0
HC-GOH	90	161	98.9
HC-AGB	145	260	98.2
HC-GOI	159	284	98.0
HC-AID	132	377	98.4

Note: We also, make multi-layer Mist Eliminators depending on specific requirements.

We also offer some of the above styles with modified structures for higher capacity and lower pressure drop.

WIN - Mesh Type Mist Eliminator Preliminary Sizing:

Mesh pads should be sized so that the face area provides a vapor rate of approximately 80% of the maximum allowable re-entrainment velocity. For estimation purposes, suitable design velocities occur at a K-factor of 0.11 m/s for vertical flow, or 0.15 m/s for horizontal gas flow (due to better drainage):-

$$V_s = K \cdot \left\{ \frac{P_L - P_V}{P_V} \right\}^{0.5}$$

where V_s = Max vapor velocity (m/s)

P_V = Vapor density (kg/m³)

P_L = Liquid density (kg/m³)

Operating pressure loss across the pad within the above design range is normally less than 50 mmH₂O depending upon mesh density, pad thickness, liquid loading and vapor rate.

An approximate pressure drop can be estimated from the formula:

$$\text{Wet } \Delta P (\text{mmH}_2\text{O}) = C \cdot (P_L - P_V) K^2 \cdot t$$

Where $C = 16.5$ for a typical 'GP-DBA' style WIN - Mesh Type Mist Eliminators, and ' t ' is the pad thickness in meters.

For optimum designs the K-factor should be modified to take into account the operating pressure, liquid viscosity, surface tension, liquid entrainment etc.

WIN - VANE TYPE

WIN - Vane Type Mist Eliminators operate over a wide range of fouling and non-fouling operating conditions.

Characteristics:

WIN - Vane Type Mist Eliminators are made of curved parallel plates with special characteristics related to the particular service to collect and drain the separated liquid.

This construction requires less maintenance due to the robust design and is suitable for wide range of services such as separators and compressor suction scrubbers with lower pressure loss along with high liquid loads.



The "V-C / V-CA" are plain, non-pocketed styles designed for larger droplet removal from vapor in normal, fouling applications with either vertical or horizontal gas flow.



WIN STYLE 'V-D'



WIN STYLE 'V-C'

The "V-D / V-DA" are designed for droplet removal from vapor flowing horizontally. In this configuration, the vanes are fitted with hooks to trap and drain the collected liquid.

WIN - Vane Type Mist Eliminators are fabricated in sections sized to fit through vessel manholes.

WIN - Vane Type Mist Eliminator Styles:

STYLE	SPECIFICATIONS	
	NO OF PASSES	HOOKS
V-C	4	NO
V-CA	3	NO
V-D	4	YES
V-DA	3	YES
V-G	7	NO

WIN - Vane Type Mist Eliminator Preliminary Sizing:

The design of WIN - Vane Type Mist Eliminators depends on many factors, but a preliminary sizing can be undertaken viz:

$$V_s = K \cdot \left\{ \frac{(P_L - P_V)}{P_V} \right\}^{0.5}$$

Where V_s = Max velocity in vanes, m/s

P_V = Density of vapor, kg/m³
 P_L = Density of liquid, kg/m³

Vane Style K-Factor

V-CA (vertical gas flow) 0.175 (m/s)
 V-CA (horizontal gas flow) 0.200 (m/s)
 V-D (horizontal gas flow) 0.225 (m/s)

Special Construction For Fine Mist Removal With High Liquid Loading

Removal of smaller droplets can be achieved using a two stage Mist Eliminator by fitting a mesh pad to the upstream face of the unit to coalesce droplets as small as 1 to 2 microns into droplets in the size range which are easily removed by the WIN - Vane Type Mist Eliminator.

WIN - Vane Type Mist Eliminators are manufactured under strict conformance and quality control guidelines. They are designed to provide optimum performance in a variety of process applications.

DV 270 (T-271) VANE TYPE MIST ELIMINATOR

The DV 270 (T-271) droplet separator is a vane type separator for droplets is directed through separator chambers which vertical flow. The gas flow charged with liquid are designed for maximum effect on the gas flow. As a result of this configuration, inertial droplets. The droplets impinge onto the profiles, where forces act on the they form a liquid film which is subsequently drained off as a result of gravity. V-shaped impressions on the separator plates ensure that the liquid is drained off in the correct manner and returns to the gas flow.



Design

Munters DV 270 (T-271) vertical flow mist eliminator has been engineered to operate at higher velocities, recover expensive chemicals, reduce operating costs and provide performance far superior to any conventional chevron or baffle type eliminator.

Opposing angle chevron collection grooves on each profile surface provide a low velocity zone where collected droplets accumulate and drain to the edges of the profile subsections. Agglomerated liquids then drain from the modules as large droplets forming a liquid stream without risk of being carried back into the separator by the up-flowing gas stream.

- The most established droplet separator for vertical flow scrubber applications
- Extremely low pressure loss
- Suitable for retrofits
- Available in PP, PPGC and stainless steel alloys
- Equipped with flushing / cleaning systems for plugging sensitive applications

LIQUID COALESCERS

WIN liquid Coalescers can solve separation problems involving immiscible liquids. Whether it is capacity constraints, loss of valuable solvents or more stringent environmental compliance, we can help you meet the requirements.

WIN - Liquid Coalescer Types:

TYPE	SPECIFICATIONS	
	MEDIA	DROPLET SIZE (µm)
CP	Corrugated Plates	>40
KM	Knitted Mesh	>20
CK	Co-knits of Wire & Filament / Fiber	>10



CATALYST BED SUPPORTS

The support chosen for a catalyst has a critical impact on catalyst activity, selectivity and ease of catalyst recycling. The support can impart an acidic or basic environment for the active catalyst component. Each support chemistry has different tendencies towards impurities which can poison the desired reaction or enhance a competing reaction. In addition, each support chemistry has a unique range of available pore size distributions and stability to thermal, hydrothermal or acidic conditions.

Functional importance:

The function of the support material is to provide a level surface on which the catalyst or adsorbent rests. The support material either fills the dished end of the reactor or rests on a support grid, if one is installed. The support material is loaded in size-graded layers such that there is relatively large material at the bottom to minimize pressure drop between the bottom of the catalyst or adsorbent bed and the gas outlet from the vessel. This is topped with an additional two or more layers of (4" in depth). The support media in these layers continue to decrease in size with the top layer being slightly smaller than the catalyst or adsorbent particle to avoid mixing of the active material into the support medium. An Active Bed Support may be used to augment inert balls performance in most adsorption applications.

In addition to the active catalysts and adsorbents, each reactor requires inert hold-down and support materials above and below the catalyst or adsorbent. The hold-down and support materials are usually spheres in various sizes of either pure alumina or alumina-silicate depending on the duty.

The function of the hold-down material is twofold. Firstly, it stops the catalyst or adsorbent particles from moving as a result of high gas velocities in the head-space of the vessel. Movement would result in irregular flow through the catalyst or adsorbent bed and in some cases, the active material milling itself to dust, leading to poor performance and rising pressure drop. Secondly, the hold-down material provides a level of protection against any particulates in the feed stream that would poison or foul the catalyst or adsorbent.

ALUMINA / INERT BALLS

Alumina Supports have a wide range of surface areas and pore volumes. The supports can be treated for excellent stability at high temperatures to avoid agglomeration/sintering of surface metals. They are appropriate for intermediate pH.

Alumina Balls are available in following sizes

Nominal sizes - mm:

3, 6, 13, 19, 25, 38, 50

Bulk density range - Kgs/Liter (lbs/ft³):

1.6 to 2.5 (100-156)

Apparent porosity range - %:

1 to 20

Crushing strength range - Kgs (lbs):

50 to 1600 (110 - 3525)

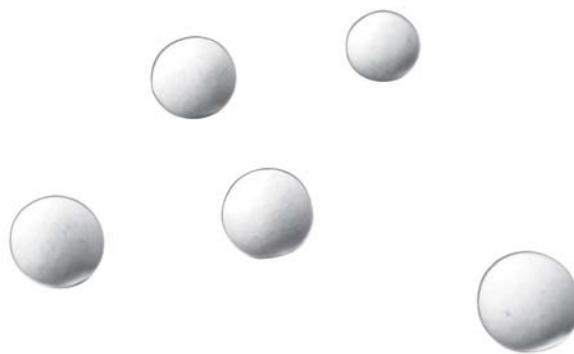

SERVICES

FEASIBILITY STUDY

We are equipped to carry out complete feasibility studies for new and revamp projects. The range of service includes process simulation, hydraulic design of columns, mechanical design and preparation of drawings. Whether it is the design or rating of an absorber, stripper, fractionator or extractor our vast experience in varied industries has helped us develop a strong database in various mass transfer applications.



DESIGN & DRAFTING



The availability of modern design software and in-house high-tech automation allows us to select the best option to perform design and drafting service for any type of mass transfer equipment. We have experience in designing & drafting of various types of packed column internals and trays, including high performance distributors/redistributors, chimney trays, high capacity valve trays, base trays and more. Our in-house engineering and manufacturing capabilities promote efficient lines of communication between our mechanical and production departments.

This permits our mechanical engineers to prepare flawless drawings resulting in fewer design revisions and world-class product quality

We provide custom design expertise for the mass transfer equipment in the new as well as the existing applications and unusual installations.

We have system for design customization and standardization which helps us to shrink the design cycle time, which further helps in reducing the delivery lead time.

SITE INSTALLATION

We provide installation services for new projects and revamp jobs pertaining to packings, trays and internals. Our team is well versed with the installation of all our products and if need arises also assist in the installation of products not designed and supplied by us.

Installation consulting services are available upon request when installation of our Mass Transfer products is performed by others. We aim to provide quick and reliable solutions to unforeseen problems that may arise during installation. Please contact our Sales Representative for more details related to this service.



TROUBLESHOOTING

You can rely on us for guidance on any design, operation and maintenance related problems. Our mass production manufacturing capabilities for components such as packings, valves, etc. will ensure

that your typical emergency replenishment requirements can be met during planned and unplanned shutdowns.

Some companies using KEVIN/MUNTERS supplied equipment include

Abu Dhabi National Oil Company - [UAE](#)
Abu Dhabi Gas Industries (GASCO) - [UAE](#)
Abu Dhabi Oil Refinery (TAKREER) - [UAE](#)
Air Products & Chemicals, Inc. - [USA](#)
Bahrain Petroleum Company - [Bahrain](#)
Bharat Oman Refineries Ltd. - [India](#)
Bharat Petroleum Corporation Ltd. - [India](#)
Brahmaputra Cracker and Polymer Limited - [India](#)
Cadila Healthcare Limited - [India](#)
Canadian Natural Resources - [Canada](#)
Cheminova - [Denmark](#)
Chennai Petroleum Corporation Limited - [India](#)
Coromandel International Limited - [India](#)
Dangote Oil Refining Company - [Nigeria](#)
Dow Chemical Company - [USA](#)
Dr. Reddy's Laboratories Ltd. - [India](#)
DuPont - [USA](#)
Essar Projects Ltd. - [India](#)
Farabi Petrochemicals Pvt. Ltd. - [Saudi Arabia](#)
Formosa Plastics - [Taiwan](#)
Gas Authority of India Ltd. (GAIL) - [India](#)
GE Water - [Kuwait](#)
Godrej Industries Ltd. - [India](#)
Grande Pariosse - [France](#)
Grasim Industries Ltd. - [India](#)
Gujarat Fluorochemicals Ltd. - [India](#)
Haldia Petrochemicals Ltd. - [India](#)
Heavy Water Board - [India](#)
Hindustan Petroleum Corporation Ltd. - [India](#)
Hismelt Kwinana - [Australia](#)
HPCL-Mittal Energy Ltd. - [India](#)
Idemitsu Kosan Global - [Japan](#)
Indian Farmers Fertilizers Co-Operative Ltd. - [India](#)

Indian Oil Corporation Ltd. - [India](#)

Indorama Eleme Fertilizers & Chemicals - [Nigeria](#)

JSC Acron - [Russia](#)

JSC Syzran Oil Refinery - [Russia](#)

Jubail Chevron Phillips Co. - [Saudi Arabia](#)

Krishak Bharti Cooperative Ltd. - [India](#)

Kuwait National Petroleum Company - [Kuwait](#)

Mangalore Refinery & Petrochemicals Ltd. - [India](#)

Mitsubishi Chemicals - [Japan](#)

National Fertilizers Ltd. - [India](#)

Numaligarh Refineries Ltd. - [India](#)

Oil & Natural Gas Corporation Ltd. - [India](#)

Oman India Fertilizer Company S.A.O.C. - [Oman](#)

Petronas - [Malaysia](#)

Qatar Fertilizer Co. S.A.Q. - [Qatar](#)

Qatar Petrochemicals Company (QAPCO) - [Qatar](#)

Rashtriya Chemicals & Fertilizers Ltd. - [India](#)

Reliance Industries Ltd. - [India](#)

Ruwais Fertilizers Industries Ltd. (FERTIL) - [UAE](#)

Saudi Basic Industries Corporation (SABIC) - [Saudi Arabia](#)

Schekinoazot OJSC - [Russia](#)

Sohar aluminium LLC/ Sohar Power - [Oman](#)

Solvay - [India](#)

State Oil Company of Azerbaijan Republic (SOCAR) - [Azerbaijan](#)

TCI Sanmar Chemicals S.A.E. - [Egypt](#)

Thai Peroxide Limited - [Thailand](#)

UOP LLC - [USA](#)

Yara Pilbara Fertilizers Pty. Ltd. - [Australia](#)



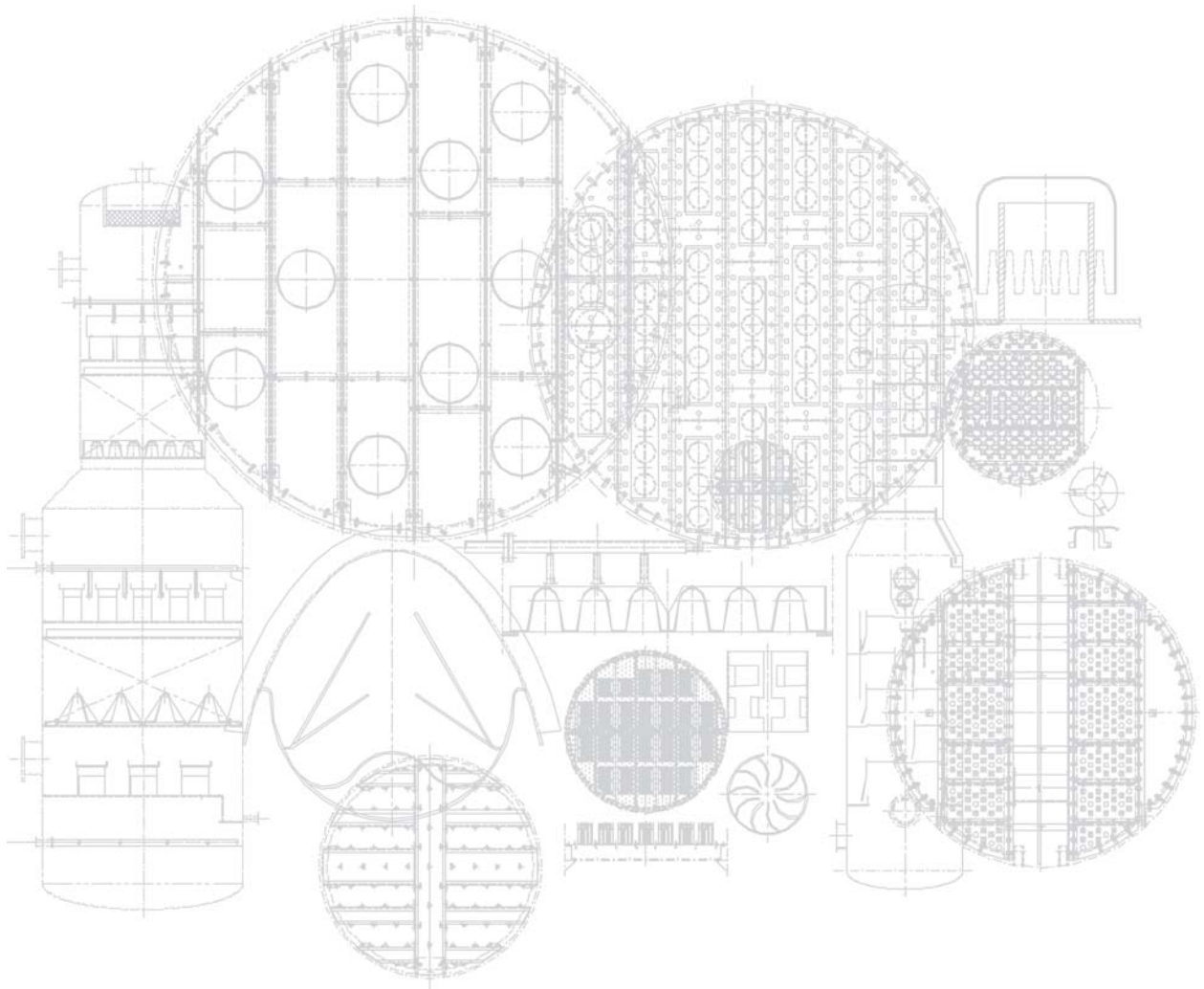

www.munters.com



Europe, Middle East & Africa

Munters Euroform GmbH, Philipsstr. 8 52068 Aachen Germany, Phone: +49 (0) 241 8900 0,
Fax: +49 (0) 241 8900-5134, Email: mst_germany@munters.de

India

Munters India Humidity Control Private Limited, Plot No.11, Street No.10, MIDC, Andheri (E)
Mumbai 400093, India, Phone: +91-(0)22-6147 8000, Fax: +91-(0)22-6147 8001, Email: contact@kevincpp.com

Asia Pacific, Australia & China

Munters Air Treatment Equipment (Beijing) Co., Ltd., No.12 Yu Hua Road, Tianzhu Airport Industrial Zone, Area B
101300 Beijing China, Phone +86 10 80 481 121, Fax +86 10 80483 493, Email: marketing@munters.cn

Americas - North, Central & South

Munters Corporation – Munters Separation Technology, 210 Sixth Street SE, P.O. Box 6428 33907 (33911) Fort Myers
Florida, USA, Phone: +1 239 936 1555, Fax: +1 239 278 1316, Email: usfmycs_me@munters.com

Your closest distributor