

# Wiring Diagram when using a RELAY PANEL CS

(Relay panel with 2 "MODULE" terminals)

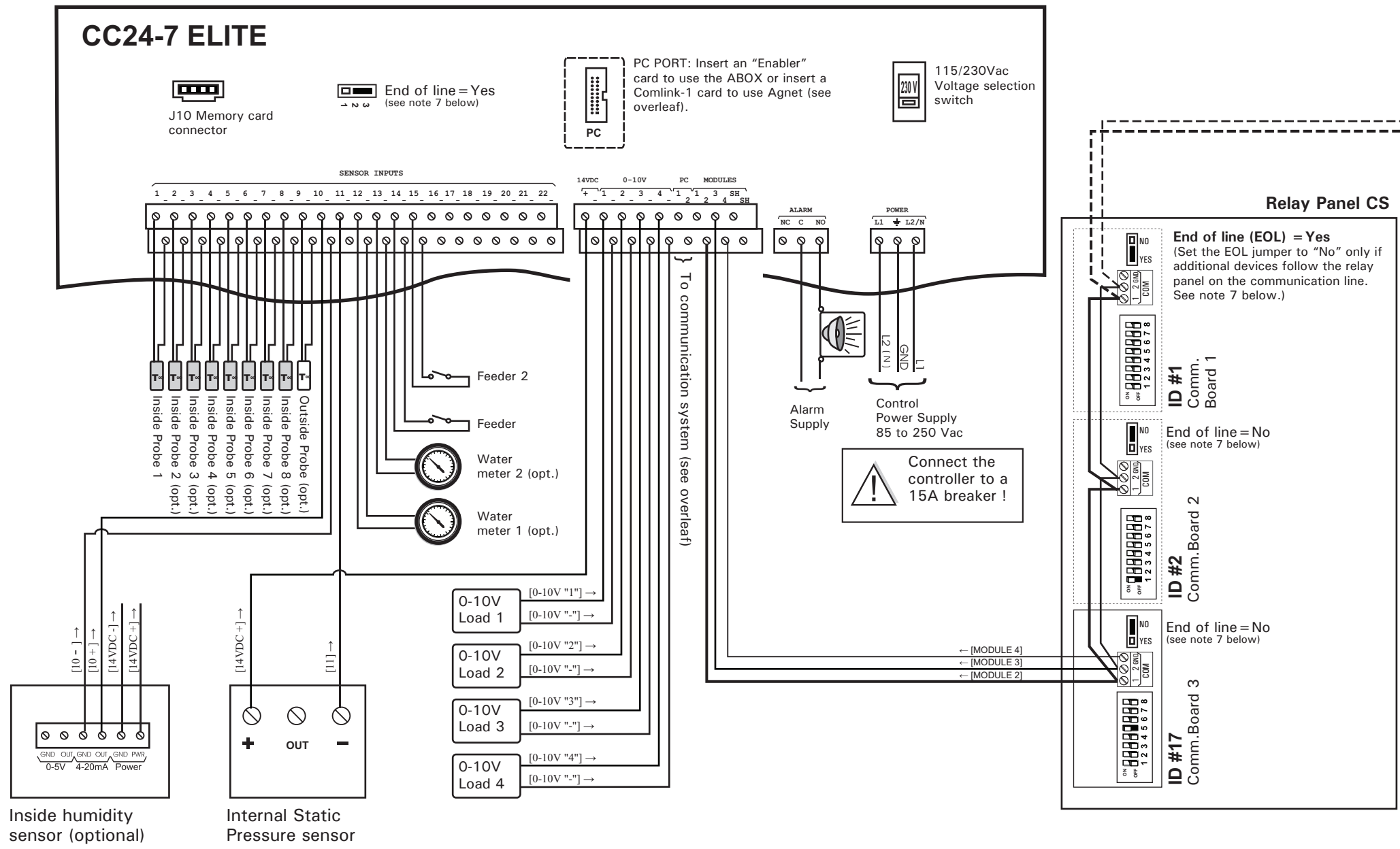

## Relay Panel CS ID Numbers

ID assignment for RP- 8 / 16 / 32 / 40 / 48			
Comm. Board 1	Relays 1-16	ID #1	
Comm. Board 2	Relays 17-32	ID #2	
Comm. Board 3	Relays 33-48 or 33-40	ID #17	
Comm. Board 4	Relays 49-64	ID #18	
Comm. Board 5	Relays 65-80	ID #19	
Comm. Board 6	Relays 81-96	ID #20	

ID assignment for RP-50			
Comm. Board 1	Relays 1-50	ID #1	

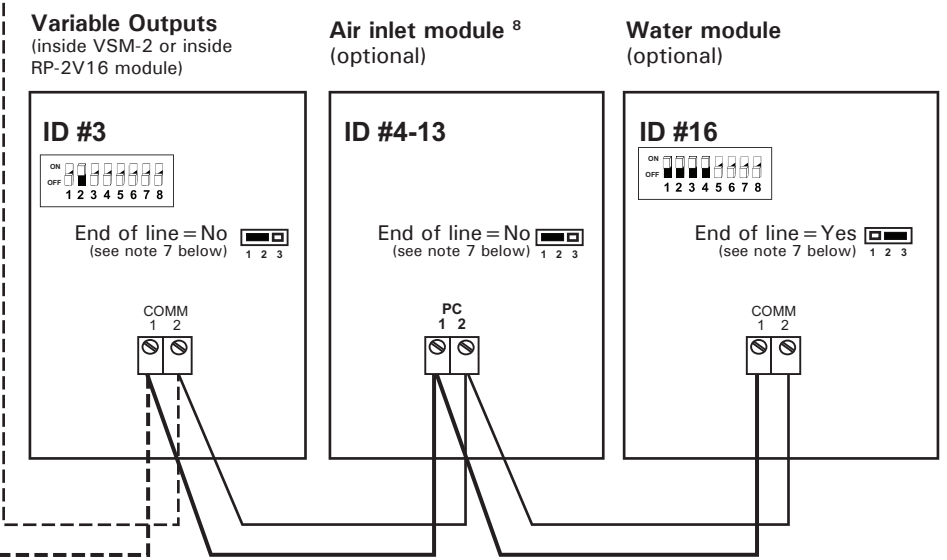

### Installation Notes:

- Mounting Instructions:** Leave a clearance of at least 16" (400 mm) to the left of the controller box to allow the cover to be removed for maintenance.
- Cable Entry:** Punch holes at the bottom of the enclosure to allow wires to be introduced in the controller. Do not drill the top or side panels of the enclosure.
- Alarm System:** Installation of a good quality alarm system is strongly suggested to warn of power failures and high/low temperatures.
- Surge Protection:** Provide a surge protection (including lightning protection) from the power supply to the controller and from the control to the sensors. Consult a certified electrician if required.
- Low Voltage Wires:** Install low voltage wires (probes & 0-10V loads) at least 12 inches (300 mm) away from high voltage wires (230-120VAC, 24Vdc). Always cross low and high voltage wires at a 90° angle.

- Water Meter:** The water meter output should be a dry contact and should not pulse faster than 60 times a second (60Hz). A 22/12 AWG gauge cable no longer than 2000 feet (0.6 km) can be used to connect the water meter. Do not use a cable longer than 2000 feet even if a larger cable is used. Do not run the meter cable outside the building!!

- End of Line Jumper (EOL):** Set the end of line jumper to the "Yes" position on the first and last device of the communication line.

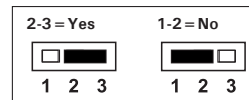

- Air Inlet ID Numbers:** Position the black jumpers properly on the Comlink card of each inlet to assign the inlet's ID number. Assign inlet ID in numerical order starting with ID#4.

- Relay Panel ID Assignment (for RP-16, RP-32 & RP-48 only):** Each group of 16 relays is linked with a communication board. Up to 3 different communication boards can be located inside a relay panel and each board must be given a unique identification number so the controller can communicate with it. Refer to the "RELAY PANEL ID NUMBER" table above to assign these number properly.

WIRING DIAGRAM	
CC24-7 ELITE	
#891-00003	Rev.13

# Wiring Diagram when using a non-CS Relay Panel

(Relay panel with 5 "MODULE" terminals)

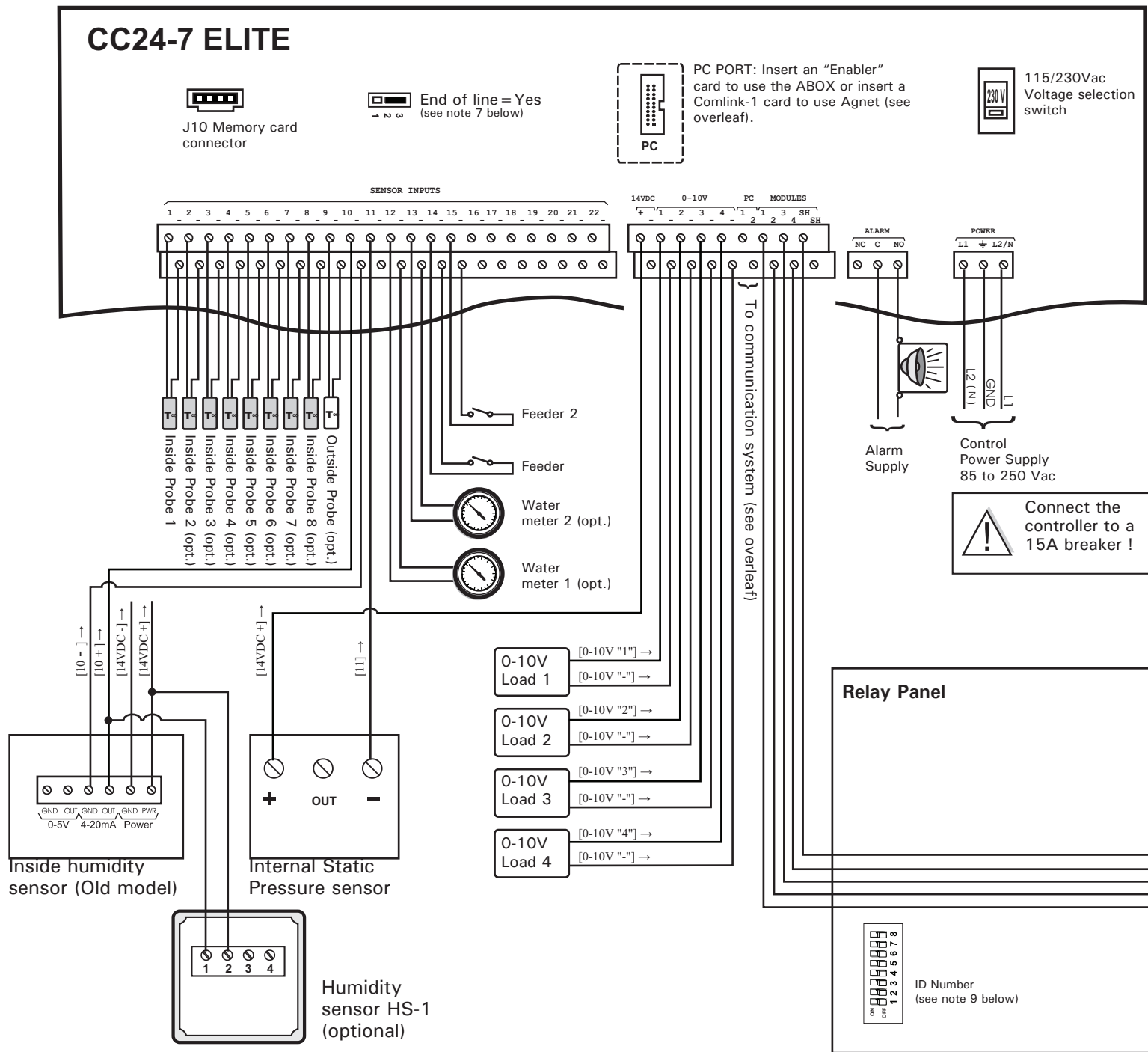

## Relay Panel ID Numbers

ID assignment for RP- 8 /16 / 32 /48			
Comm. Board 1	Relays 1-16	ID #1	
Comm. Board 2	Relays 17-32	ID #2	
Comm. Board 3	Relays 33-48	ID #17	
Comm. Board 4	Relays 49-64	ID #18	

ID assignment for RP-50			
Comm. Board 1	Relays 1-50	ID #1	
Comm. Board 1	Relays 51-100	ID #2	

### Variable Outputs

(inside VSM-2 or inside RP-2V16 module)

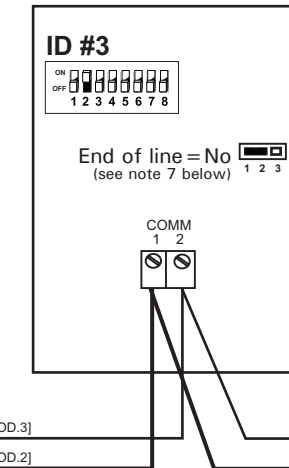

### Air inlet module <sup>8</sup>

(optional)

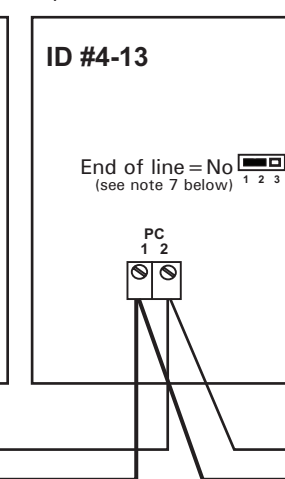

### Water module

(optional)

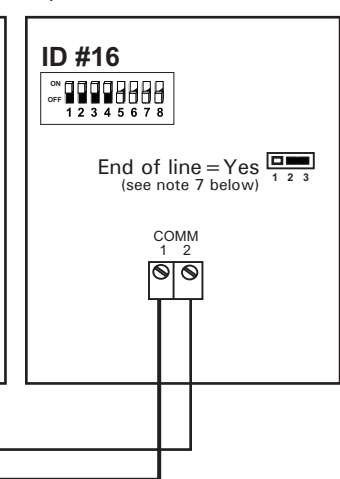

## Installation Notes:

- Mounting Instructions:** Leave a clearance of at least 16" (400 mm) to the left of the controller box to allow the cover to be removed for maintenance.
- Cable Entry:** Punch holes at the bottom of the enclosure to allow wires to be introduced in the controller. Do not drill the top or side panels of the enclosure.
- Alarm System:** Installation of a good quality alarm system is strongly suggested to warn of power failures and high/low temperatures.
- Surge Protection:** Provide a surge protection (including lightning protection) from the power supply to the controller and from the control to the sensors. Consult a certified electrician if required.
- Low Voltage Wires:** Install low voltage wires (probes & 0-10V loads) at least 12 inches (300 mm) away from high voltage wires (230-120VAC, 24Vdc). Always cross low and high voltage wires at a 90° angle.
- Water Meter:** The water meter output should be a dry contact and should not pulse faster than 60 times a second (60Hz). A 22/12 AWG gauge cable no longer than 2000 feet (0.6 km) can be used to connect the water meter. Do not use a cable longer than 2000 feet even if a larger cable is used. Do not run the meter cable outside the building!!
- End of Line Jumper (EOL):** Set the end of line jumper to the "Yes" position on the first and last device of the communication line.

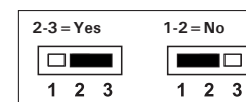

<b>WIRING DIAGRAM</b>	
<b>CC24-7 ELITE</b>	
#891-00003	Rev.13

### A-BOX Communication System Hook-up (optional)

\* Refer to the Surelink manual to set the end of line jumpers (EOL) properly.

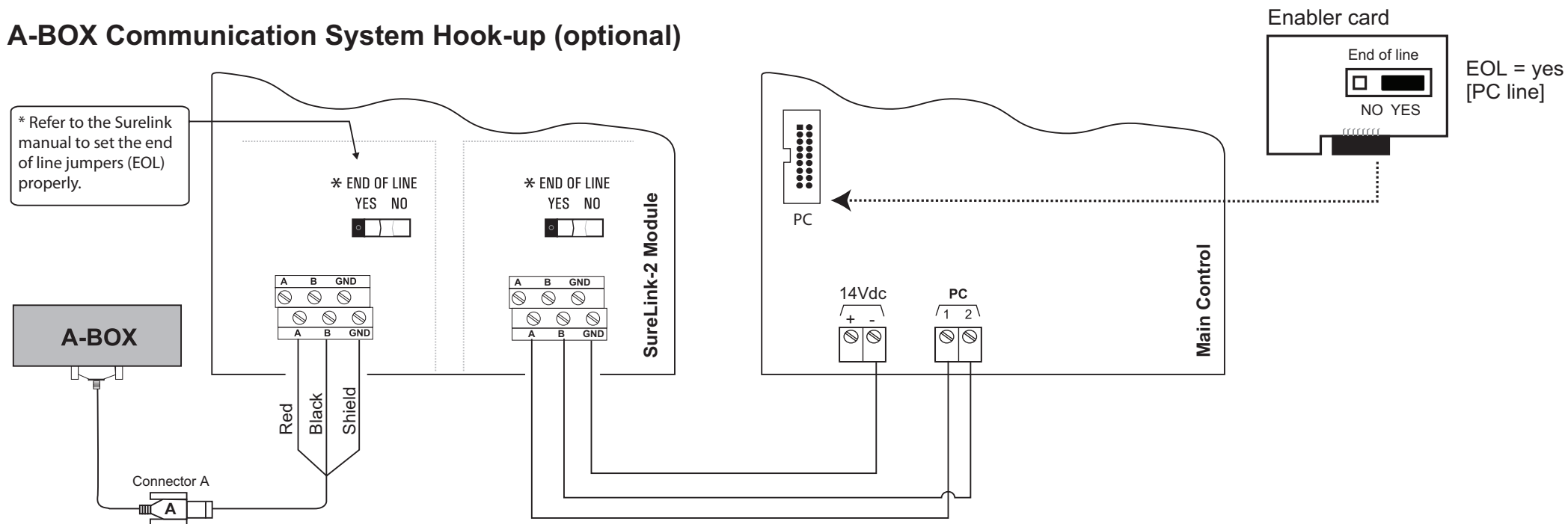

NOTE: In order to connect the CC24-7 Plus to an A-Box, you must use an A-com card 045-11540 rev01.

### AgNet Communication System Hook-up (optional)

