

Manual for use and maintenance

Farm
Center /
Farm
Master



Farm Center / Farm Master

Climate Controller for Pigs

Farm Center and Farm Master

Manual for use and maintenance

Revision: N.2.6 of 23.12.2014

Product Software: Version 1.04

This manual for use and maintenance is an integral part of the apparatus together with the attached technical documentation.

This document is destined for the user of the apparatus: it may not be reproduced in whole or in part, committed to computer memory as a file or delivered to third parties without the prior authorization of the assembler of the system.

Munters reserves the right to effect modifications to the apparatus in accordance with technical and legal developments.

Index

<i>Chapter</i>		<i>page</i>
1	INTRODUCTION -----	6
	1.1 Disclaimer-----	6
	1.2 Introduction-----	6
	1.3 Notes-----	6
2	PRECAUTIONS -----	7
	2.1 Grounding -----	7
	2.2 Filtering -----	7
	2.3 Checking the battery level-----	7
	2.4 Frequency inverters-----	7
3	INTRODUCTION -----	8
	3.1 Components-----	8
	3.2 General description -----	8
	3.2.1 Farm Center.....	8
	3.2.2 Farm Master.....	8
	3.3 Features -----	9
	3.3.1 Farm Center features.....	9
	3.3.2 Farm Master features.....	9
	3.4 Farm Center / Farm Master network connections -----	10
4	GETTING STARTED -----	12
	4.1 10 Step installation guide -----	12
	4.2 Farm Center keyboard -----	13
	4.3 Farm Center main-screen -----	13
	4.4 Hotkeys -----	14
	4.5 Farm Center setup -----	17
5	CONTROL MENU -----	19
	5.1 Temp Curve-----	19
	5.2 Min. Max. Level -----	20
	5.2.1 Soft Min Max Levels by Day levels.....	21
	5.3 Humidity-----	21
	5.4 Static Pressure -----	22

5.5	System Parameters -----	23
5.5.1	System Parameters details	24
5.6	Control Mode-----	26
6	DEVICE MENU -----	27
6.1	Vent Levels -----	27
6.2	Variable Fan Levels-----	29
6.3	Curtain Levels -----	29
6.4	Circulation Fan -----	30
6.5	Cool Pad -----	30
6.6	Foggers -----	31
6.7	Light-----	32
6.8	Feed -----	32
6.9	Extra System-----	32
6.10	Time Clocks-----	33
6.11	Variable Heat-----	33
7	MANAGEMENT MENU-----	34
7.1	Animal Inventory -----	34
7.2	Day & Group -----	34
7.3	Alarm Setting-----	35
7.4	Alarm Reset-----	36
7.5	Version -----	36
7.6	Read From Plug -----	36
7.7	Write To Plug -----	37
8	HISTORY MENU-----	38
8.1	Temperature-----	38
8.2	Humidity-----	38
8.3	Water -----	39
8.4	Feed -----	39
8.5	Mortality-----	39
8.6	Heater-----	40
8.7	Alarm-----	40
8.8	Event-----	41
9	CALIBRATION MENU -----	42
9.1	Temperature-----	42
9.2	Humidity-----	42
9.3	Pressure-----	42
9.4	Water & Feed-----	42

10	INSTALLATION MENU	43
10.1	Relay Layout	43
10.2	Sensors Layout	44
10.3	Digital Input	44
10.4	Analog Output	44
10.5	Variable Speed Fan	45
10.6	Sensor Definition	45
10.7	Curtain Setup	45
11	FARM MASTER	46
11.1	Cold Start	46
11.2	Set unit number	46
11.3	Main Menu	46
11.4	Calibration	46
11.4.1	Temperature sensor calibration	46
11.4.2	Calibration procedure	47
11.5	Test	47
12	SPECIFICATIONS	48
13	MECHANICAL INSTALLATION GUIDE	49
13.1	Sensors and shielded wiring	49
13.2	Installation and electrical connections	49
13.3	Mechanical installation guide	50
13.4	Environmental protection	50
13.5	Metal sheet assembly diagram	51
13.6	Communication wiring diagrams	53
14	WARRANTY	55

1 Introduction

1.1 Disclaimer

Munters reserves the right to make alterations to specifications, quantities, dimensions etc. for production or other reasons, subsequent to publication. The information contained herein has been prepared by qualified experts within Munters. While we believe the information is accurate and complete, we make no warranty or representation for any particular purposes. The information is offered in good faith and with the understanding that any use of the units or accessories in breach of the directions and warnings in this document is at the sole discretion and risk of the user.

1.2 Introduction

Congratulations on your excellent choice of purchasing an Farm Center / Farm Master set!
In order to realize the full benefit from this product it is important that it is installed, commissioned and operated correctly. Before installation or using the fan, this manual should be studied carefully. It is also recommended that it is kept safely for future reference. The manual is intended as a reference for installation, commissioning and day-to-day operation of the Munters Controllers.

1.3 Notes

Date of release: July 2010

Munters cannot guarantee to inform users about the changes or to distribute new manuals to them. All rights reserved. No part of this manual may be reproduced in any manner whatsoever without the expressed written permission of Munters. The contents of this manual are subject to change without notice.

2 Precautions

- Grounding
- Filtering
- Checking the battery level

2.1 Grounding

- Always connect temperature and sensor shields to earth ground. Avoid mixing high voltage wiring with sensor and low voltage wiring.
- Keep the controller as far as possible from heavy contactor boxes and other sources of electrical interference.
- Do not connect communication wire shields, which go from one house to another at both ends. Connect them at one end only. Connection at both ends can cause ground loop currents to flow, which reduce reliability.
- The COM connection for communications is not the shield wire. The COM, RX and TX wires must connect to each other at all controllers.

2.2 Filtering

If this installation includes a power inverter to drive variable speed fans, install an EMI filter in front of the inverter, according to the specifications provided by the inverter manufacturer. Refer to the inverter documentation.

2.3 Checking the battery level

Check the battery once a year. The output must be 2.7 volts (minimum). Authorized personnel only must replace the battery if the output is below the minimum required level or every five years.

2.4 Frequency inverters

Frequency inverters can cause severe electrical and electromagnetic interference. Therefore, when employing a frequency inverter, it is critical that you carefully follow the manufacturer's installation instructions.

In particular verify:

- that the cable shielding between the inverter and any motor meets industry standards
- proper grounding of the inverter's chassis and motor power cable
- proper grounding of low voltage cable shield wire
- that the controller and inverter cables are kept in separate conduits or wire bundles

3 Introduction

- Components
- General description
- Features
- Farm Center / Farm Master network connections

This manual provides easy-to-use information for installation, operation, long/short term planning and parts listing. The table of contents is an outline of the relevant information in this manual.

Read this manual before operating your Munters Controller. If you have any questions or comments regarding your controller please contact your local Munters dealer.

3.1 Components

- Farm Center
- Farm Master
- Extension Box (optional)
- MUX 485 Communication or Farm Guard (optional)

3.2 General description

- Farm Center
- Farm Master

3.2.1 Farm Center

The **Farm Center** provides maximum capability with minimal complexity in programming and controlling up to 10 **Farm Master** units. **Farm Center** is the ultimate pig house controller. Equipped with an easy programming interface, it provides programmable outputs for all major features and a 4x20 character LCD that provides display feedback on the programming and device status.

The **Farm Center** communicates with **Farm Master** units to access history, collect events and alarms for each and all relevant data up to 100 days.

3.2.2 Farm Master

Farm Master's user-friendly has high performance and quick response time. **Farm Master** features accurate temperature and humidity sensors, secure transmission of data even in noisy environments and the added convenience of eight output relays as well as four analog outputs.

Each **Farm Master** can operate independently, in case of **Farm Center** malfunction or loss of power. Using an internal battery when the **Farm Master** is operating "alone", there is no history collection or possibility to change parameters.

NOTE Using an internal battery when the Farm Master is operating "alone", there is no history collection or possibility to change parameters.

3.3 Features

The following sections detail the Farm Center and Farm Master features.

- Farm Center features
- Farm Master features

3.3.1 Farm Center features

- Easy programming
- LCD - 4x20 characters
- Positioning scrollbar
- Swift device and feature selection
- Data plug
- Large numeric keypad
- Communication with up to ten Farm Master units
- Extensive history of events & alarms
- Data Collection
- Real time visual outlook
- Alarm system (for every Farm Master unit)
- Multi language Support.
- PC communication

3.3.2 Farm Master features

- Easy programming
- Programmable outputs
- Alarm system
- Large display
- Up to 3 temperature sensors
- Up to 8 heavy duty relays (1 HP)
- On/Off/Auto override switches
- Static pressure control (optional)
- 4 Analog output (0-10 volts)
- Variable speed fan output with bypass
- Water, feed, and humidity control
- Automatic calibration of curtains

3.4 Farm Center / Farm Master network connections

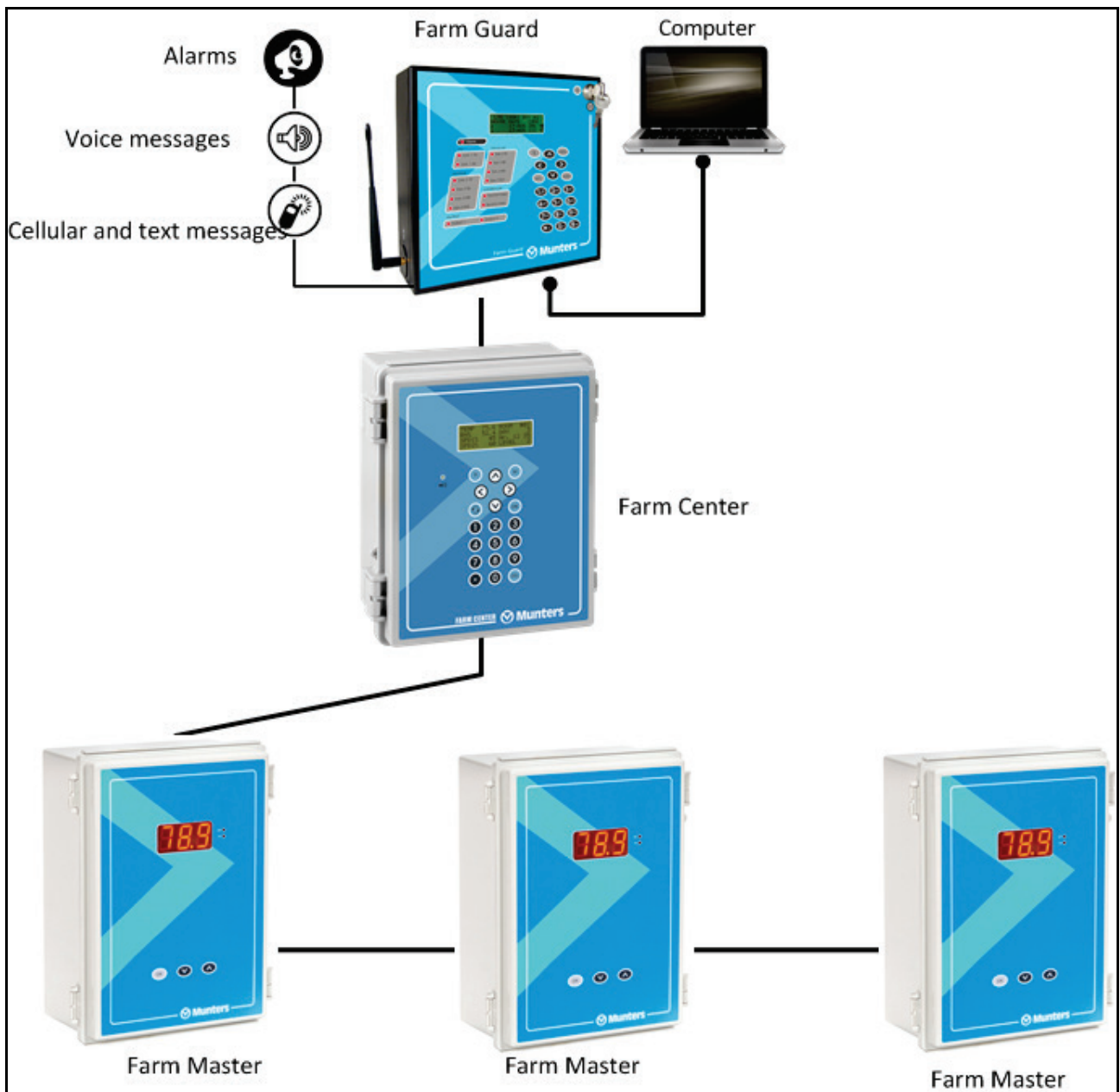

Figure 1: Farm Guard - Farm Center - Farm Master network

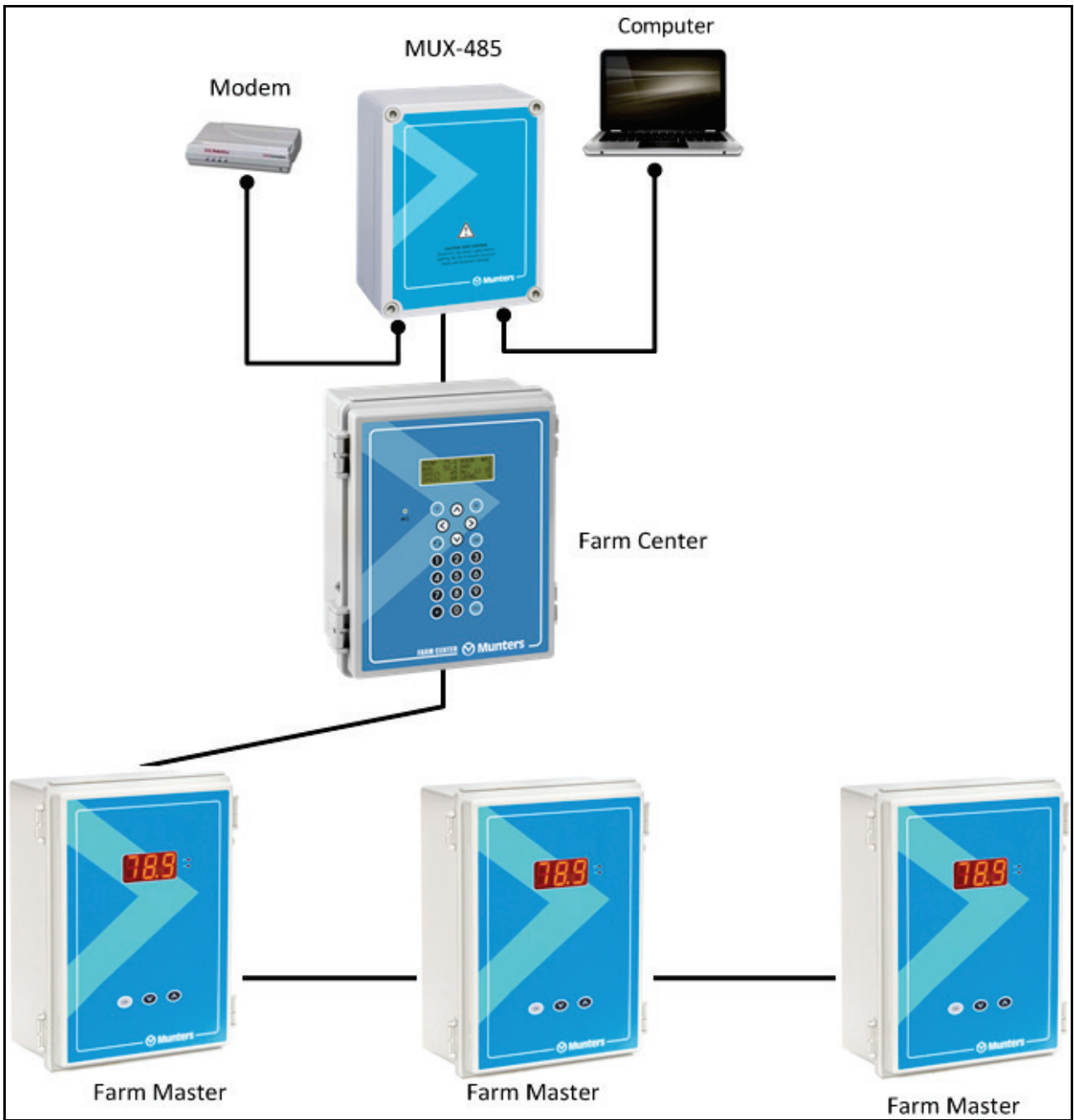

Figure 2: MUX - Farm Center - Farm Master network

4 Getting started

The following sections explain the basic concepts in using the Farm Center and Farm Master controllers.

- 10 Step Installation Guide
- Farm Center Keyboard
- Farm Center Main-screen
- Hotkeys
- Farm Center Setup

4.1 10 Step installation guide

This is a quick **10 step** guide that will help you figure out the order of actions for a proper system installation:

1. **Hardware Installation:** Read all technical specs and use the wiring diagrams, from page 48 on this manual, to properly install all hardware.
2. **Farm Master Cold Start:** Plug in the controller and hold its three keys simultaneously for a few seconds until a CLD sign will appear. This action erases the memory completely and loads the default definitions.
3. **Farm Master Unit Number:** Press the two arrow keys together until the number sign (no.) blinks. Select the unit number with the up and down arrows and press Select.
4. **Farm Center Cold Start:** Plug in the controller and hold the delete key (DEL) for a few seconds until a Cold Start sign will appear. This action erases the memory completely and loads the default definitions.
5. **Farm Center setup (Room #0):** Follow the instructions on page 17.

NOTE Before making any changes make sure you are changing the correct room by checking the room number on the upper right side of the screen.

6. **Farm Center Installation:** Follow the instructions from page 43. If you have more than one room, don't forget to change room number and install the rest.
7. **Farm Center Calibration:** Calibrate your equipment on each room using the service menu.
8. **Farm Center Control:** Follow the instructions from page 19 regarding the control parameters for each room.
9. **Farm Center Device:** Follow the instructions from page 27 regarding the device settings for each room.
10. **Farm Center Management:** Follow the instructions from page 34 regarding livestock and alarm management for each room.

NOTE The History menu is for viewing purposes only.

4.2 Farm Center keyboard

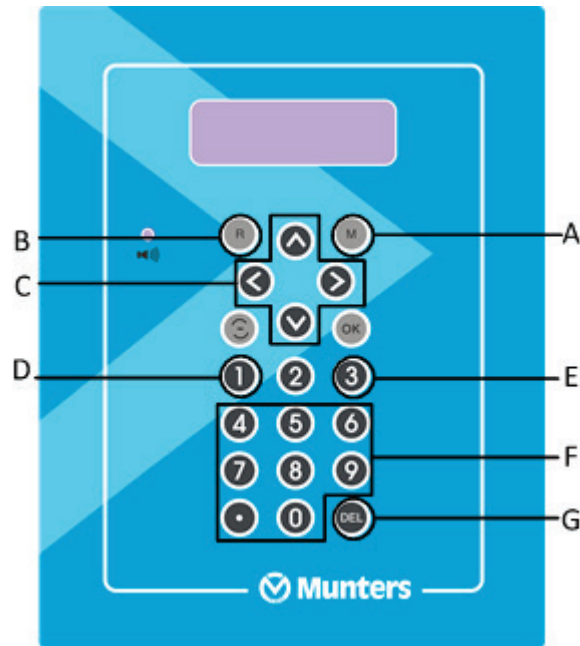

A	Menu	Toggles the menu function
B	Room	The room key is used to switch between rooms. Press the room key and press a number to reach the desired room.
C	Arrows	Use the arrows to scroll a short press in any direction moves one notch.
D	Round Arrows	The Round Arrows key is used to scroll between options (Yes/No, On/Off and '!').
E	Enter	The enter key is a confirmation key.
F	Numeric Pad	The Number keys are selected when a numeric choice is done and when numbers should be selected. Moreover, those keys are used for Hot Keys purposes.
G	Delete	The 'Delete' key erases typing mistakes.

4.3 Farm Center main-screen

TEMP	27.1	ROOM	#01
RH%	75.0	DAY	1
TRGT	24.0	Hr.	13:21
RH%T	80.0	LEVEL	1

NOTE The main screen shows basic information regarding rooms controlled by the Farm Center, depending on what equipment is plugged in. Other parameters like static pressure (PRESS), outside temperature (OUT), level, message and offset are also shown on the main screen when they are plugged in. Parameters are shown according to priority. There is a square in level line indicating tunnel level.

TEMP	Current room temperature
RH%	Current room humidity
TRGT	Target temperature
RH%T	Target humidity
OUT	Outside Temp.
ROOM #01	Room number
DAY	Growth day
Hr.	Time
LEVEL	Current ventilation level.

CAUTION In case of an alarm, a blinking message will appear on any one of the main screens in addition to the siren. Pressing "0" on the main screen, when the alarm message is on, will direct you to the room with the alarm. Resetting the alarm is possible, but it only stops the siren and not the screen message. Only by fixing the problem will the message stop.

Pressing the zero on the numeric pad, while the alarm is activated will open the room status screen.

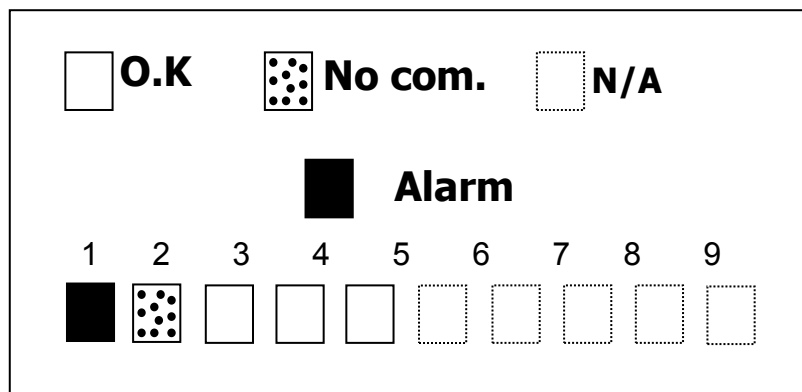

- An empty square indicates that the Farm Center identifies the houses correctly.
- A filled square indicates an alarm is on.
- A dotted square indicates that there is no communication with the **Farm Master**.

NOTE Once communication is off there is no history accumulation in the Farm Center.

- A dotted lined square indicates N/A (not available).

4.4 Hotkeys

To activate the Hotkeys screens, press the Hotkey number while viewing the main screen. The room number is located on the upper right side of the Hot screen to view the status of deferent rooms, first enter the desired room using the room key and pressing the room number. Then press the desired screen Hotkey number.

- **Hot key 1:** Main screen
- **Hot key 2:** Temperature screen

The temperature hot screen shows important information regarding the status of temperature sensors attached to the Farm Center. The average temperature (defined in table 6.6) is displayed on the upper left side and shows the average of temperature sensors T1 through T3. Table 6.2 enables the user to set the temperature sensor T3 as 'OUT' and therefore T3 presents the outside temperature. On the right side, you can see the temperature for entering tunnel ventilation mode.

T1	24.4	#01	
T2	25.1	AVG.	22.9
T3	22.5	TUN.	23.
		OUT	22.5

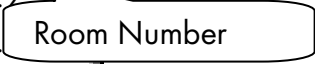

- **Hot key 3:** Targets Screen

This screen shows all of the target levels, selected for any of the controller's functions.

TARGETS		#01	
TEMP	22.5	PRESS	0.01
MIN LEVEL	5	ON	60
MAX LEVEL	15	OFF	240

- **Hot key 4:** Curtain Position screen

This screen shows the curtain opening position in percent. If for example curtain 2 show 40%, it is 40% open.

CURTAIN POSITION		#01	
CURT.1	50	CURT.2	CL
CURT.3	40	CURT.4	-
TUNNEL	OP	INLET	-

- **Hot key 5:** Curtain Steps

This screen shows the number of steps for each curtain.

CURTAIN STEPS		#01	
CURT.1	12	CURT.2	-
CURT.3	14	CURT.3	-
TUNNEL	-	INLET	-

• **Hot key 6:** System Status

This screen shows if humidity treatment is ON/OFF, if the cycle is ON/OFF and how many seconds left for the current cycle.

SYSTEM STATUS	#01
HUMIDITY TREAT.	ON/OFF
CYCLE STATUS	ON/OFF
CYCLE LEFT	29

• **Hot key 7:** Variable Fans

This screen shows the speed percent of each variable fan.

VARIABLE FANS	#01		
FAN 1	30%	FAN 3	n/a
FAN 2	40%	FAN 4	n/a

• **Hot key 8:** Variable Heat

This screen shows the percent of each variable heat.

VARIABLE HEAT	#01
HEAT 1	70%
HEAT 2	n/a

• **Hot key 9:** Relay Status

This option shows active relays, pressing 9 again will open the extension box's relay activity

RELAY STATUS	#01
R1- <input type="checkbox"/> R2- <input checked="" type="checkbox"/> R3- <input type="checkbox"/> R4- <input checked="" type="checkbox"/>	Relay Active
R5- <input type="checkbox"/> R6- <input type="checkbox"/> R7- <input type="checkbox"/> R8- <input type="checkbox"/>	Relay Not Active
EXTENSION RELAYS '9'	

• **Hot key Round Arrow key:** History Temperature

This option shows a summary of temperature according to temperature room. This screen consists of the following columns;

- Day number ('Day' column)
- Minimum value measured on that day ('Min' column)
- Average value calculated on the measured temperatures through the whole day ('Avg' column)
- Maximum value measured on that day ('Max' column)

TEMPERATURE ROOM #1			
DAY	MIN	AVG	MAX
23	21.4	23.5	24.5
24	21.8	24.6	24.7

4.5 Farm Center setup

To reach the Farm Center Setup screen:

1. Go to Room key.
2. Press '0' and "Enter" from any of the main screens.

The Farm Center setup is a procedure for customizing the Farm Center and Farm Master units to match the system.

Farm Center		↑
===COMM.===		
Farm Center#	1	↓
PC.Baudrate	4800	

Total Rooms	5	
=Language=		
Language	►English	
===UNITS===		
Temp.	►F	
Press	►IN.W.C	
Other Units	IMPER	
=OUT TEMP.=		
From Room	►1	
===TIME===		
Time(hh:mm)	►12:06	
=PASSWORD=		
Full Access	0	
Read Only	► 0	

The following table explains the parameters.

FARM CENTER	Farm Center identity (Max-32). Define the Farm Center's unit number. If only one Farm Center exists, the unit number is 1. Otherwise, the unit numbers are sequential (1, 2, 3,...).
BAUDRATE	Select communication baud rate with the PC.
TOTAL ROOMS	Set the number of Farm Master units connected to the Farm Center (Max-10). Make sure you define the Farm Masters' numbers in a following order without skipping digits. For example: 1,2,3,4... If not set this way, the Farm Center will not detect any Farm Masters. After defining the number of Farm Master controllers, the Farm Center begins a search to find the controllers defined.
LANGUAGE	Select language.
TEMPERATURE UNIT	Select between Celsius and Fahrenheit.
PRESSURE	Select between: Milibar, IN.W.C, Pascal, CM.W.C, MM.W.C.
OTHER UNIT	Select between meter and imperial. Controls the speed and rain flow. Units for speed are meter/h or mile/h and for rain millimeter/h or inch/h.
TIME	Set clock time.
PASSWORD	Set password to protect data.

NOTE The last six parameters are general for all Farm Masters.

5 Control menu

- Temp Curve, page 19
- Min. Max. Level, page 20
- Humidity, page 21
- Static Pressure, page 22
- System Parameters, page 24
- Control Mode, page 26

5.1 Temp Curve

TEMP CURVE #01				Heat	Tunnel	Low Alarm	High Alarm
#	Day	Target	→				
1	1	23.3	↓	21.1	37.2	21.1	37.2
2	14	22.2		20.0	37.2	10.0	35.0
3	42	21.1		18.8	32.2	10.0	35.0
4	70	20.5		17.8	29.4	10.0	35.0
5	98	20.0		16.6	26.6	10.0	32.2
..10							

The Farm Master provides separate temperature curves for growth day, target temperature, heat temperature, tunnel temperature and low/high alarm temperatures. The controller creates a curve for each one and uses it as reference. The program will alter at midnight prior to the next day on the next row programmed. There are up to 10 programmable rows, but the controller will maintain yesterday's settings for every empty line, therefore it is not necessary to fill the entire table.

Limits:

- Day 0 - 999
- Target 0 - 40° C
- Alarm low 0 - 40° C (without floating point)
- Alarm high 0 - 40° C (without floating point)

5.2 Min. Max. Level

1 By Day		
Day	Min	Max
1	1	21
14	3	30
98	9	30

2 Soft Minimum By Day			
Day	Min Cold	Min Warm	Max
1	1	11	25
14	3	13	30
98	9	19	30

3 Soft Minimum By Time			
From Time	Min Cold	Min Warm	Max
8:00	1	7	25
20:00	3	5	23

4 By Time		
From Time	Min	Max
8:00	1	21
20:00	3	21

The Minimum/Maximum Level menu sets the current absolute minimum and maximum ventilation levels available. You have 4 minimum maximum level choices:

- Min/Max by Growth Day (1)
- Min/Max by Time of Day (2)
- Soft Min/Max by Day or Time (3 or 4)

The third option provides the following; in extreme cold weather the min level ventilation might be decreased. For that, the user utilizes the Soft Min level that operates according to outside or inside temperature.

For example:

- Target temperature = 23.3°C
- Growth day = 1

5.2.1 Soft Min Max Levels by Day levels

Day	Min Cold	Min Warm	Max
1	1	10	30

System parameters -> Min/Max

- Level control DSFT (Soft Min by days)
- Soft Min temp Out (Control by outside temperature)
- Soft Min Band 2.2°C (Differential below heat temperature)

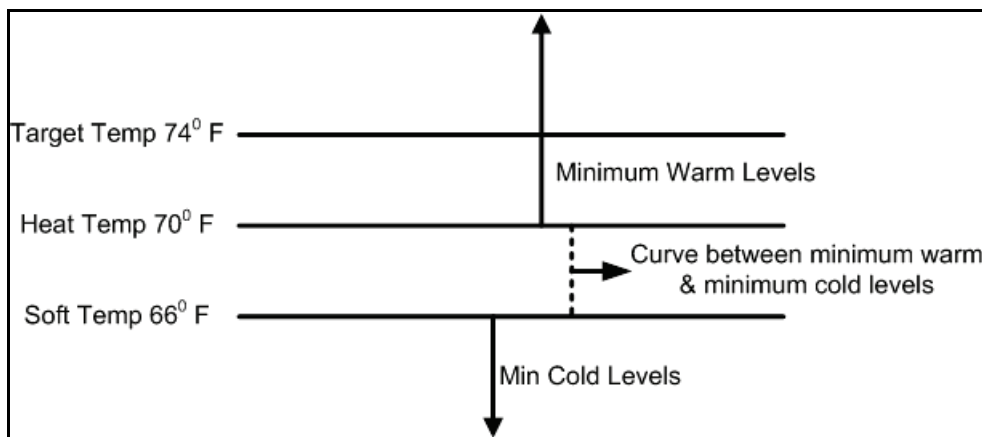

If the inside temperature is above 21 ° C (heat temperature) the controller will operate according to the Min Warm levels.

If the inside temperature is below 19° C (Soft Temp) the controller works according to Min Cold levels. When the temperature is between 21 ° C and 19° C the controller creates a curve between the Min Cold and Min Warm levels. For example, in 20° C the controller operates in level 5.

Important:

- When using Soft Min according to **inside** temperature there is a curve between min warm and min cold, while decreasing levels. When temperature increases the level remains at the lowest level reached, until reaching the heat temperature.
- When using Soft Min according to **outside** temperature there is a curve between min warm and min cold while decreasing and increasing levels.
- To select the type of minimum/maximum go to system parameters and change the level control (see page 21).

5.3 Humidity

HUMIDITY #01	
Target	0
Delay (minute)	0
Duration (sec)	0
Band (%)	2
Below Heat	NO

- **Target:** Set the humidity target for.
- **Delay:** Delay time before humidity treatment. The controller checks during the delay time whether the humidity is above the target.
- **Duration:** Humidity treatment duration time.
- **Band:** Band zone to balance the treatment.
- **Below heat:** Select if you wish to initiate humidity treatment below heater temperature.

5.4 Static Pressure

STATIC PRESSURE #01	
Out temp low	5
Press. (low t)	0.08
Out temp high	35
Press. (high t)	0.12
Tunnel press.	0.08
Low alarm	0.05
High alarm	0.15
Band	0.04
Wind delay (s)	10
Pre open (s)	5
Alarm MINIMUM level	0

- **Out Temp low:** Set outside low temperature definition for low pressure target.
- **Press (Low T):** Static pressure target for the outside low temperature (See graph below, point 1).
- **Out Temp High:** set outside high temperature definition for high pressure target.
- **Press (High T):** Static pressure target for outside high temperature (See graph below, point 2).
- **Tunnel Pressure:** Static pressure target during tunnel ventilation mode.
- **Low Alarm:** If static pressure drops below set point alarm will be active.
- **High Alarm:** If static pressure rises above set point alarm will be active.
- **Band:** Set band zone to balance the system.
- **Wind Delay:** Static pressure is affected by wind. This definition is to ensure that an alarm is given due to a stable change in pressure and not an accidental one, which may have been caused by a wind gust.

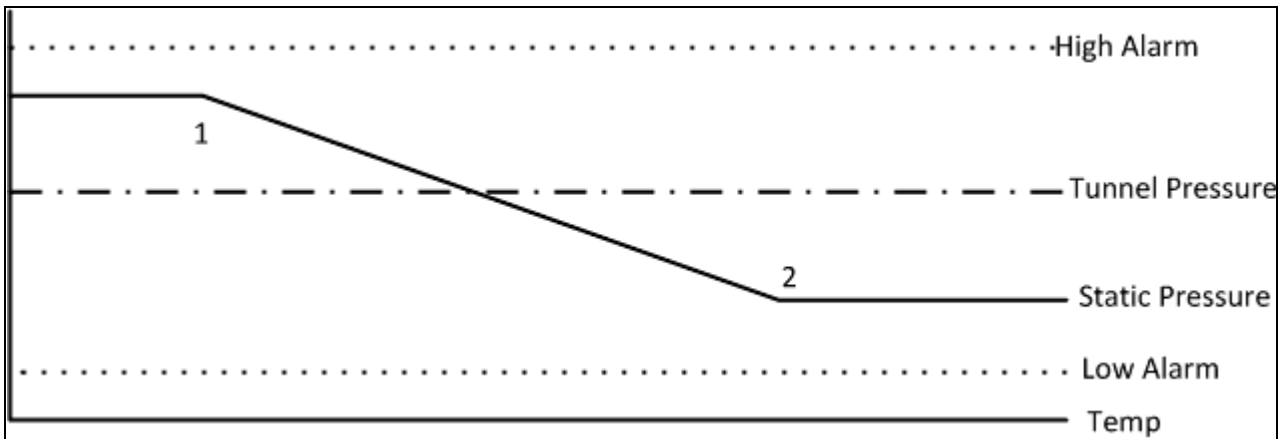

- **Pre Open:** Time setting for curtains to open before fans activate. This is to make sure the curtains are open before fan activity.
- **Alarm minimum level:** from what level you wish to activate low static pressure alarm.

5.5 System Parameters

SYSTEM PARAMETERS	
=====TEMP=====	
Offset	▶ 0.0
Band	1.0
Cool Factor	10%
Cold Above TRG	3.0
Cold Below TRG	1.0
=====HEATER=====	
Heat Band	1.0
Heat Lamp Diff	0.0
Heat Offset	0.0
=====MIN MAX=====	
Curve	NO
Level Control	Day
Soft Min Temp	OUT
Soft Temp Band	10.0
=====PRESSURE=====	
Press Control	NO
=====LEVELS=====	
Inc Delay (s)	180
Dec Delay (s)	120
=====TUNNEL=====	
1 st Tun Level	0
Dif Below, Exit	2.0
T.Out Dif, Exit	18.0

Exit Delay (m)	5
====CURTAINS====	
Calib Steps	99
==COOL PAD==	
From Level	0
Temp Band	1.0
Humidity Band%	2.0
====FOGGERS====	
From Level	0
Temp Band	1.0
Humidity Band%	2.0
====VAR. FAN====	
Freeze Protect	NO
Min Fan 1 Spd%	30
Min Fan 2 Spd%	30
Min Fan 3 Spd%	30
Min Fan 4 Spd%	30

5.5.1 System Parameters details

- ==TEMP==
 - Offset: Use this parameter to change the offset target temperature up or down for any purpose. Default: 0.0
 - Band: this refers to the target temperature zone range. The User's Manual refers to this as the Happy Zone. Default: 1.0
 - Cool Factor (%): the minimum correction towards target happy zone during each increase ventilations delay (patience factor). If the temperature does not improve by this amount, the controller will increase one level. Default: 10%
 - Cold Above TRG: Temp Change To Be Considered As Quick Drop In Degrees, To Reduce A Level To Reach Above Target Temp (Degrees). Default: 3.0
 - Cold Below TRG: Temp Change To Be Considered As Quick Drop In Degrees, To Reduce A Level To Reach Below Target Temp (Degrees). Default: 1.0
- ==HEATER==
 - Heat Band: Set the happy zone for the heaters on/off. Default: 1.0
 - Heat Lamp Diff: differential from target temperature to initiate heat lamps. Default: 0.0
 - Heat Offset: Use this parameter to change the offset Heat temperature up or down for any purpose. Default: 0.0
- ==MIN MAX==
 - Curve: If Yes - Min max table curve between the days. Default: NO - Will work according to previous line until current day.
 - Level Control: Four options for the min max table method: by days, soft minimum by days, by time, soft minimum by time. Default: Day
 - Soft Min Temp: choice whether to use the current inside temperature or the outside temperature to determine when to use the soft minimum. Default: OUT
 - Soft Temp Band: diff below heat temperature to set temperature at which to enforce low temperature minimum ventilation level. Default: 10.0

- ==PRESSURE==
 - Press Control (Yes / No): If a pressure control should be done in Min Vent mode by the inlet and in Tunnel mode by tunnel curtain, select **Yes**. Otherwise, select **No**. Default: No.
- ==LEVELS==
 - Inc Delay Time: this is the standard minimum delay before increasing ventilation levels. Default: 120 (sec)
 - Dec Delay Time: this is the standard minimum delay before decreasing ventilation levels. Default: 180 (sec)
- ==TUNNEL==
 - 1st Tunnel Level: switching into and out of tunnel ventilation is a major change in ventilation. For tunnel ventilation, enter the first tunnel level here. If set on 0 there is no tunnel level. Default: 0
 - Dif Below, Exit: this parameter sets amount below the tunnel entry temperature at which to exit tunnel ventilation. Tunnel temperatures are determined by the sensors specified in Temperature Definition. Entry and exit is also controlled by these sensors. The controller cannot exit tunnel until the tunnel temperature is this much less than the tunnel entry temperature. It must be a positive number. Default: 2.0
 - T.Out Dif, Exit: set the relative temperature for the outside sensor at which to exit tunnel. The controller cannot exit tunnel until the outside temperature is less than tunnel temperature plus this differential. This number can be positive or negative. To eliminate the effect of this parameter on tunnel exit, enter a large positive number such as 90.0. Default: 0.0
 - Exit Delay (m): delay time after satisfying tunnel exit conditions. Default: 5 (minutes)
- ==CURTAINS==
 - Calibration Steps: to ensure accurate positioning of the curtains, the controller may periodically calibrate the curtain position. This parameter sets the maximum number of curtain movements or stages between calibrations. Calibration consists of forcing the curtain to the nearest limit, 0% or 100% with adequate overtime to ensure reaching the limit switch. Then the curtain returns to its proper position. In the event several curtains require calibration, they calibrate one at a time to reduce the amount of restriction to normal ventilation. The stage counter resets automatically each time the curtains reach a limit point to prevent excessive calibration. Default: 99
- ==COOL PAD==
 - From Level: from what ventilation level to begin cool pad operation. 0 is no operation. Default: 0
 - Temp Band: on/off differential or Happy Zone with respect to temperature for the 'Cool #' and 'Cool Pad #' relays. These normally control the water pump for the cool cells. Default: 1.0
 - Humidity Band: on/off differential or Happy Zone with respect to inside humidity for the 'Cool #' and 'Cool Pad #' relays. Default: 2.0
- ==FOGGER==
 - From Level: from what ventilation level to begin fogger operation. 0 is no operation. Default: 0
 - Temp Band: See cool pad above. Default: 1.0
 - Humidity Band: See cool pad above. Default: 2.0
- ==VAR. FAN==
 - Freeze Protect: A general protection for the variable speed fan motor. When the variable speed fan starts from zero speed, the freeze protection activates it to 100% for 5 seconds. Default: No
 - Min Motor1, 2, 3, 4 Spd: Safety speed fan operation delay. This is the Fan minimum speed to begin operation. Default: 30.

5.6 Control Mode

CONTROL MODE #01	
Set Mode	▶Normal
	Empty

In this screen control mode can be set, choosing between Normal Mode and Empty Mode.

Empty Mode

Empty Mode is applied in cases of empty houses. When Empty Mode is selected:

- All alarms are disabled
- A flashing message appears while displaying temperature
- "E" In Farm Master and "Empty House" in Farm Center

Setting controller to Normal or Empty mode inserts an event to History/Event table.

6 Device menu

- Vent Levels, page 27
- Variable Fan Levels, page 29
- Curtain Levels, page 29
- Circulation Fan, page 30
- Cool Pad, page 30
- Foggers, page 31
- Light, page 32
- Feed, page 32
- Extra System, page 32
- Time Clocks, page 33
- Variable Heat, page 33

6.1 Vent Levels

VENT LEVELS		#01		
#	12345678	on	Off	Diff
01	●	30	240	0
02	◐	40	220	0
30	■			

The Farm Center provides up to 30 programmable ventilation levels. The usual way to program them is to start the first level with the least amount of air to be used.

- The full circles represent continuous fan operation.
- ◐ The half full circle represents cycle operations according to the on/off time set for each stage.
- A dot represents no operation at all.

The following table is an example of a proper ventilation setting. Note that tunnel is not noticeable on the current table and is set according to the system parameter- 1st tunnel level.

Level	Tunnel Fans								On	Off	Diff
	1	2	3	4	5	6	7	8			
1	◐	◐							30	570	0.0
2	◐	◐							40	560	0.0
3	◐	◐							52	548	0.0
4	◐	◐							70	530	0.0
5	◐	◐							90	510	0.0
6	◐	◐							30	270	0.0
7	◐	◐							40	260	0.0
8	◐	◐							52	248	0.0
9	◐	◐							70	230	0.0
10	◐	◐							90	210	0.0
11	◐	◐							120	180	0.0
12	◐	◐							160	140	0.0
13	●	●	◐						225	75	0.0
14	●	●	◐						300		0.0
15	●	●	◐						100	200	0.0
16	●	●	◐						70	230	0.0
17	●	●	◐						90	210	0.0
18	●	●	◐						120	180	0.0
19	●	●	●						160	140	0.0
20	●	●	●	●					225	75	0.0
21	●	●	●	●					0	0	0.0
22	●	●	●	●	●	●			0	0	1.0
23	●	●	●	●	●	●			0	0	2.0
24	●	●	●	●	●	●	●		0	0	3.0
25	●	●	●	●	●	●	●		0	0	4.0
26	●	●	●	●	●	●	●		0	0	5.0
27											
28											
29											

6.2 Variable Fan Levels

SPEED (%) #01					
#	Fan 1	Fan 2		Fan 3	Fan 4
01	30	32	→	0	0
02	20	25	↓	0	0
...30					

- The percentage for a full circle represents the fan operation percentage from the maximum. If set on 30% it will operate up to 30% of the maximum.
- The percentage for a half full circle represents the fan operation percentage in off mode during cycle operation. The fan will operate at 100% at on time. If set on 20%, the fan will operate at 20% of the full power during off time in the cycle and will increase to 100% at on time.

6.3 Curtain Levels

CURTAIN (%) #01						
#	Crt. 1	Crt. 2	Crt. 3	→ Crt. 4	Tun.	inlet
01	0	0	0	0	0	15
02	0	0	0	0	0	15
...30	0	0	0	0	0	15

Curtain Level Example						
Level	Curtain (% Open)					
	1	2	3	4	Tunnel	Inlet
Levels 1 thru 17	0	0	0	0	0	15
	·	·	·	·	·	·
	·	·	·	·	·	·
	·	·	·	·	·	·
	0	0	0	0	0	15
18	0	0	0	0	30	
19	0	0	0	0	45	
20	0	0	0	0	70	
21	0	0	0	0	100	
22	0	0	0	0	100	
23	0	0	0	0	100	
24..30	0	0	0	0	0	

Set the curtain levels to correspond with the ventilation levels. Some producers will want to open the tunnel curtain somewhat prior to the actual tunnel. This is convenient to control pressure in retrofit houses which may not have sufficient side inlets for the number of fans required in side ventilation.

You can also optionally run the tunnel curtain under pressure control. In that event, the percent open settings become minimum settings. Then, once the side vents are at 100%, if pressure requires, the Master will open the tunnel curtain to maintain the pressure setting.

6.4 Circulation Fan

CIRCULATION FAN #01		
Sensors Dif	3.0	
From Time	00:00	→
To Time	00:00	
From Level	1	↓
To Level	10	

The circulation fans will mix the air inside the house and control temperature differentials between different parts of the house.

- **Sensors Dif:** the circulation fan will start if the difference between temperatures in different parts of the house will be higher than the set differential. The sensors that participate in this differential can be divided in to 3 groups:
 - If no sensors are set for circulation fans in temp definition, the current defined sensors will control this operation. If for example the house is in tunnel mode, the tunnel sensors will control the circulation fans. If there will be difference higher then 3 (like the example above) between 2 sensors the circulation fans will begin to operate.
 - If one sensor is defined for the circulation fans, the difference between this sensor and the average will control the circulation fans.
 - If more than one sensor is defined for the circulation fans, when the difference increase between any 2 sensors, the circulation fans will begin operation.
- **From Time:** from what time to start the application.
- **To Time:** to what time operate this application.
- **From Level:** from what level to operate this application.
- **To Level:** up to what level operate this application.

If any of the four definitions above is set on 0, the circulation fan operates at any time or level according to the differential.

6.5 Cool Pad

Cool Pad #01							
#	From	To		Diff	%RH	On	Off
1	08:00	20:00	→	3.0	85	30	90
2	10:00	18:00		5.0	75	60	60
			↓				

The cooling table provides settings for the evaporative cool pad system. There are up to 5 fragments allowing precise control over this system. Several fragments can be selected for the same day.

- FROM: (HH:MM) Start time.
- TO: (HH:MM) End time.
- DIFF: Differentiation from tunnel temperature to activate cooling. When the temperature rises this amount above the tunnel target, cooling process begins. When temperature goes back to the tunnel target, cooling process stops.
- %RH: As long as the humidity + Band are below this level the cooling operates.
- Cooling stops only at humidity level + band. (See figure below)
- ON/OFF: (sec) On/Off cycle by seconds.
- Band: The cooling table has its own 'happy zone' for temperature and humidity that can be set at the system parameters under cooling section. The cooling system turns on the amount above specified in the column 'Diff' and turns off when the temperature drops the amount specified in the band.

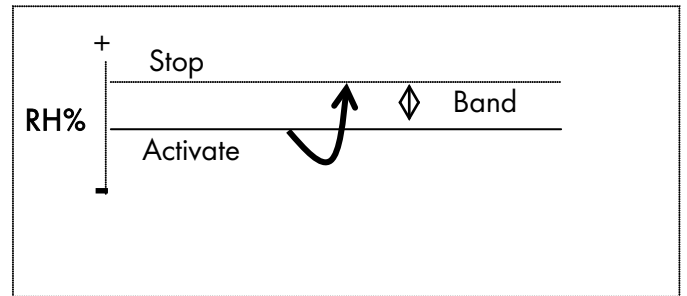
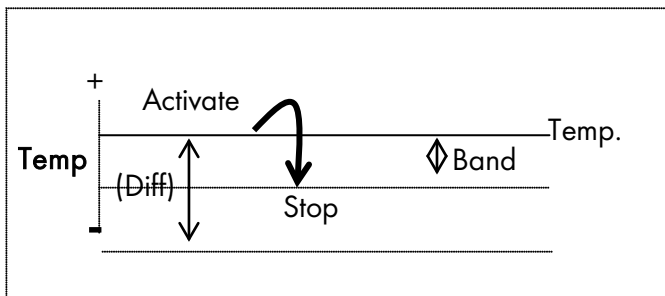

6.6 Foggers

Foggers #01							
#	From	To		Diff	%RH	On	Off
1	08:00	20:00		3.0	85	30	90
2	10:00	18:00		5.0	75	60	60

The Foggers' table provides settings for the fogger system. There are up to 5 fragments allowing precise control over this system. Several fragments can be selected for the same day.

- FROM: (HH:MM) Start time.
- TO: (HH:MM) End time.
- DIFF: Differentiation from target temperature to activate foggers. When temperature raises diff above target, fogger's process will begin. When temperature reduces back to target, fogger's process will stop.
- %RH: As long as the humidity + Band are below this level the foggers operates.
- Foggers stop only at humidity level + band. (See figure below)
- ON/OFF: (sec) On/Off cycle by seconds.

6.7 Light

LIGHT			
#	Day	From	To
1	1	14:00	12:00
2	5	10:00	16:00

Set the on/off times according to growth day, there are up to five programmable lines.

6.8 Feed

FEED			
#	Day	From	To
1	5	10:00	12:00
2	10	14:00	16:00

Set from what hour to what hour you want the feeding to take place, there are up to five programmable lines.

6.9 Extra System

EXTRA SYSTEM #01							
#	From	To	→	From T.	To T.	on	off
1	10:00	12:00	↓	15	40	20	50
2	14:00	16:00	↓	15	50	30	60

Any relay can be set as an extra system. There are up to 3 functions (relays) available to program as extra system.

The extra system's relays will activate according to the settings in this table and regardless of the conditions, or other devices.

- **FROM:** (HH:MM) Start time.
- **TO:** (HH:MM) End time.
- **To/From Temperature (From T./To T.):** the temp range for extra system activity.
- **ON/OFF:** (sec) On/off cycle by seconds.

This table consists of up to five programs.

6.10 Time Clocks

TIME CLOCKS #01					
#	From	To	→	on	off
1	10:00	12:00	↓	20	50
2	14:00	16:00		30	60

This is a simple device definition table with operation time and cycle. There are up to 5 functions (relays) available to program as time clocks.

6.11 Variable Heat

VARIABLE HEAT #01		
	Heat1	Heat2
Ht Diff	0.0	0.0
Band	10.0	10.0
Min(%)	30	30
Max(%)	100	100
End Day	0	0

- **Heat Diff:** Differential from heat temperature to initiate variable heaters. **Default:** 0.0
- **Band:** Temperature range in which the variable heater operates in the power range between minimum and 100%. For example: the heater temperature is 26 °C, the temp diff is -1 and the temp band is 2. At 25 °C the heater will operate at minimum power according to minimum heat. At 24 °C and down the heater will operate at 100% and between 26 °C and 24 °C there will be a power band between minimum and 100%. **Default:** 0.0
- **Minimum Heat:** Minimum heaters operation for safety measures. This parameter refers to both var. heat 1 and var. heat 2. **Default:** 30%
- **Maximum Heat:** Maximum heaters operation for safety measures. This parameter refers to both var. heat 1 and var. heat 2. **Default:** 100%
- **End Day:** Set the last growth day for the Variable Heaters operation. **Default:** 0

7 Management menu

- Animal Inventory
- Day & Group
- Alarm Setting
- Alarm Reset
- VersionRead From Plug
- Write To Plug

7.1 Animal Inventory

ANIMAL INVENTORY #01	
Add Mortality	2
Animal Placed	1000
Animal Update	998

This table provides an update for animal inventory.

- Add Mortality: insert mortality.
- Animals Placed: insert animals placed.
- Animal Update: update number of animals.
- In case the wrong figures are accidentally entered, it is possible to correct them by entering negative figures.

7.2 Day & Group

DAY & GROUP #01	
Growth Day	2
New Group	Yes/no
Group No.	4

Day and group keeps monitor the growth of groups

- Growth Day: Set the number of growth day. This parameter can also help determine the animals age.
- New Group: To start a new group, select YES under new group fragment and the controller will automatically increase group number by one and set growth day to 1.

CAUTION When starting a new group, History is deleted!!!

- Group No.: You can manually change the group number.

7.3 Alarm Setting

ALARM SETTING	
Alarm Delay	▶ 60
=SENSOR ALARM=	
Low Alarm Diff	18.0
Hi. Alarm Diff	18.0
====HIGH TEMP====	
Out Compensate	0.0
Emergency Temp	35
====LOW TEMP====	
Var Fan Stop	NO
=====WATER=====	
Min Water/hour	0
Max Water/hour	0
=====FEED=====	
Min Feed/hour	0
Max Feed/hour	0
===Aux. Alarm===	
Aux Relate f()	NONE

- **Alarm Delay (sec):** represents the number of seconds between failure detection and the alarm operation.

NOTE If the problem is solved before the delay time ends, an alarm will not be recorded in the history log.

- ==SENSOR ALARM==
 - **Low/High:** High and low temperature ranges beyond which alarm is activated.
- ==HIGH TEMP==
 - **Out Compensation:** This parameter is added to the high temperature alarm when outside temperatures are high, like noontime in desert countries. Ensuring you won't get an alarm just because it's a hot day. The emergency temperature has no compensation, so the compensation feature only works when temperatures do not exceed the emergency temperature.

Example: Outdoor+comp.> Alarm then Alarm = Outdoor+Comp.

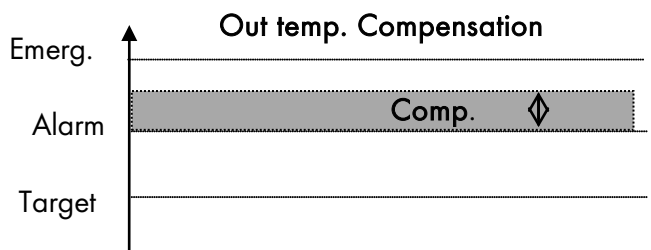

For example: IF the preset compensation is 1 °C, the outside temperature is 24 °C and alarm is set to 25 °C, the controller adds the outside temperature to the comp, and the alarm will rise to 26. (25+1=26)

- **Emergency Temp.:** The temperature beyond which the controller goes into emergency mode and an alarm is activated.
- **==LOW TEMP==**
 - **Variable Speed Stop (Yes/No):** When in low temperature alarm, decide whether to keep variable speed in minimum operation or totally shut down the function.
- **==WATER & FEED==**
 - **Min/Max Water/Hour:** A quantity of water per hour, above which alarm will activate.
 - **Min/Max Feed/Hour:** A quantity of feed per hour, above which alarm will activate.
- **==AUX. ALARM==**
 - When assigning a related function, alarm occurs if the associated digital input fails to follow the relay. Digital input must be active when its associated relay is on.
 - If there is no related function the alarm will turn on when digital input is active.

7.4 Alarm Reset



NOTE To reset the alarm press Enter and use the Round Arrows key to change from NO to YES.

7.5 Version

Use this window to check the controller's software version.



Use the arrow keys to switch between controllers and press select to view the software version.

7.6 Read From Plug

There are two types of data plugs regular and gold. The gold data plug can store up to 8 different settings. By naming each setting differently you can easily write/read data from the plug to the controller and vice versa.

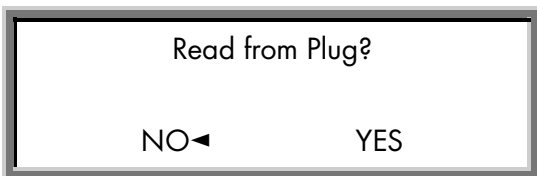

Use the arrow keys to shift from NO to YES and press Enter to read from data plug.

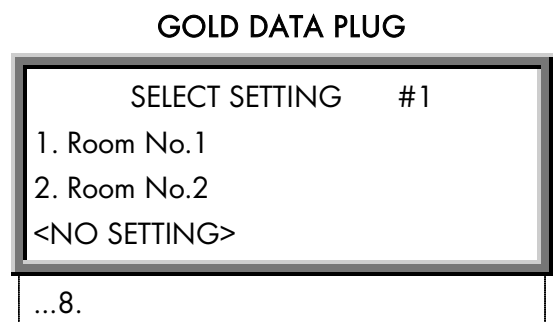

```

DATA ON THE PLUG
Name: Room No. 1
Ver.: 1.00r01
OK→ENTER, Abort MENU

```

Before loading the setting, you can view setting name and software version for this setting. Press enter to load the data on the controller. To cancel reading from this setting, press MENU.

```

READING FROM PLUG
-----
PLEASE WAIT

```

7.7 Write To Plug

```

Write to Plug?
NO◀      YES

```

```

GOLD DATA PLUG
SELECT SETTING #1
1. Room No.1
2. Room No.2
3. <NO SETTING>
...8.

```

Use the arrow keys to shift from NO to YES and press Enter to write over the data plug.

You can name your current configuration by using the arrow keys.

On the gold data plug, select no setting to create a new setting or overwrite an existing one.

```

ENTER SETTING NAME
Name: Room No. 1
To Change ARROWS
OK → ENTER, Abort MENU

```

Press enter to load data to the plug.

8 History menu

The history section maintains a memory of activity of the last 100 days and 100 events or alarms.

- Humidity
- Water
- Feed
- Mortality
- Heater
- Alarm
- Event

8.1 Temperature

TEMPERATURE #01			
DAY	MIN	AVG	MAX
1	24.5	25.8	26.5
2	24.0	25.0	26.5
.			
100			

8.2 Humidity

HUMIDITY #01			
DAY	MIN	AVG.	MAX
1	55.0	60.0	67.0
2	55.0	60.0	66.0
.			
100			

- **Sensors:** Data collection for minimum, maximum and average in temperature and humidity for the last 100 days.

8.3 Water

WATER #01		
DAY	DAILY	%
1	0.0	N/A
2	0.0	N/A
.		
100		

- **DAY:** Growth day.
- **DAILY:** Daily consumption.
- **%CHANGE:** % Change from previous day.

8.4 Feed

FEED #01		
DAY	DAILY	%
1	0.0	N/A
2	0.0	N/A
3	0.0	N/A
.		
100		

- **DAY:** Growth day.
- **DAILY:** Daily consumption.
- **%CHANGE:** % Change from previous day.

8.5 Mortality

MORTALITY #01		
DAY	DAILY	TOTAL
1	0	N/A
2	1	1
.		
100		

- **DAY:** Growth day.
- **DAILY:** Daily mortality.
- **TOTAL:** Mortality total since growth day one.

8.6 Heater

HEATER ROOM #01		
DAY	Heat 1	Heat 2
1	01:05	00:00
2	00:42	00:00
.		
100		

The Heater History shows the amount of HH:MM the heater was on that day.

8.7 Alarm

ALARM #01			
	MESSAGE	TIME	DAY
■	Press. Fail	18:50	18
▣	High Temp	10:45	14

The following is an example of an Icon status that indicates activation of alarms.

- NOT ACTIVE
- AN ALARM THAT WAS RESET
- ACTIVE

There are 21 different possible alarm messages:

1. Ana. In Fail: Analog input failure
2. High Temp: High temperature alarm
3. Low Temp: Low temperature alarm
4. Hum.Sen Fail: Humidity sensor failure
5. Lost Comm: Lost communication
6. W. Overflow: Water over flow
7. F. Overflow: Feed over flow
8. Sn. 1 Fail: Sensor #1 failure.
9. Sn. 2 Fail
10. Sn. 3 Fail
11. Sn.1 Def Err: Sensor definition error
12. Sn.2Def Err
13. Sn.3 Def Err
14. Sn.1 Out Rng: Sensor out of range
15. Sn.2 Out Rng
16. Sn.3 Out Rng
17. Sn. Not Def: Sensor not defined
18. Aux Alarm: Auxiliary alarm.
19. Press. Fail
20. Low S. Press.
21. High S. Press.

8.8 Event

EVENTS ROOM #1			
	EVENT	DAY	TIME
1	Menu #11	2	18:53
2	Power up	4	14:42

The events table is similar to the alarms table but without icons. For example: In the table above "menu #11" means that there was a change of settings in CONTROL menu 1, Temp Curve table.

9 Calibration menu

- Temperature
- Humidity
- Pressure
- Water & Feed

9.1 Temperature

TEMP. CALIB. #01
Temp-1(Factor)▶ 0.0
Temp-2(Factor) 0.0
Temp-3(Factor) 0.0
Temp-4(Factor) n/a

The temperature sensor is a very accurate sensor with a deviation of 0.1. If needed, calibrate the temperature sensor by using a very accurate reference instrument and enter the offset number for each sensor in the Temp factor line. Use the up and down arrow keys to select sensors.

9.2 Humidity

HUM. CALIB. #01
Humid.(factor)▶ 0.0

If needed, calibrate the humidity sensor by using a very accurate reference instrument and enter the offset number in the Humidity factor line.

9.3 Pressure

PRESS. CALIB. #01
Value A/D
Press ENTER to calib

9.4 Water & Feed

Water/Feed #01
Water per pulse 0.1
Feed per pulse 1.0

The water and feed system operates on a pulse counting method. Enter the amount of feed/water per pulse.

10 Installation menu

CAUTION Always connect temperature and sensor shields to earth ground.

CAUTION Avoid mixing high voltage wiring with sensor and low voltage wiring.

CAUTION Keep the controller as far as possible from heavy contactor boxes and other sources of electrical interference.

- Relay Layout
- Digital Input
- Variable Speed Fan
- Curtain Setup
- Sensors Layout
- Analog Output
- Sensor Definition

10.1 Relay Layout

RELAY LAYOUT #01	
#	FUNCTION
01	Heater 1
02	Heater 2

Each relay can be defined to any of the functions on the following list:

- None
- Fan 1-8
- Curt. 1-4 open
- Tunnel close
- Light
- Extra system 1-3
- Heater 1-2
- Cool Pad
- Curt. 1-4 close
- Inlet open
- Feed
- Timer 1-5
- Heat lamp 1-2
- Foggers
- Tunnel open
- Inlet close
- Circulation

10.2 Sensors Layout

ANALOG INPUT #01		OPTIONS
Temp-1	IN	IN / NONE
Temp-2	NONE	IN / NONE
Temp-3	NONE	IN / NONE
Temp-4	OUT	NO / YES/OUT
Humidity	YES	NO / YES

The Sensor Layout accommodates up to four temperature sensors and one humidity sensor. Three can be defined for use inside the house and up to one can be used out of the house. Mark "IN" for a temperature sensor connected in the house and OUT for a temperature sensor outside of the house.

NOTE Only sensor number 4 can be 'Out'.

10.3 Digital Input

DIGITAL INPUT #01		OPTIONS
Input-1	Water	None / Water / Feed / Aux. Alarm
Input-2	Feed	
Input-3	None	

There are three digital inputs and a selection between water, feed, auxiliary alarm or none.

- **AUX. ALARM:** Once this function begins to operate, a digital input is sent to make sure that it is actually on; if not the alarm starts.

10.4 Analog Output

ANALOG OUTPUT #01	
# FUNCTION	0% 100%
1 Var. Heat 1	0.0 10.0
2 Var. Heat 2	0.0 10.0
3 Var. Fan	3
4 Var. Fan	4

Use the Round Arrows key to run through the list of outputs and press enter to select an output.

10.5 Variable Speed Fan

VAR. SPEED FAN #01
FUNCTION
1 VAR. Fan 1 ► YES
2 VAR. Fan 2 YES

To define a speed fan select yes. This table fills out according to the number of TRIACS in the system (0 - 2).

10.6 Sensor Definition

FUNCTION	1	2	3	4
Average	+	-	+	-
Tunnel	+	-	-	-
Heater 1	+	-	-	-
Heater 2	-	+	-	+
Heat Lamp 1	-	+	-	-
Heat Lamp 2	-	-	-	+
Curtain 1	+	+	-	-
Cool cell	-	-	-	-
Ex. System 1	-	-	-	-
Tun. Curt	-	-	-	+
Var. Heat 1	-	-	+	-

Select the temperature sensors 1 - 4 to use for each function using the Round Arrows key to apply or remove check marks. You will see only the devices defined in the relay layout and variable heat.

NOTE *Average*: the average definition refers to the average temperature, according to the sensor defined. An empty line defined for a certain sensor, indicates that the sensor will operate according to the average temperature definition.

10.7 Curtain Setup

CURTAIN SETUP #01		
CURTAIN	OPEN	CLS
Curtain1 ►	60	60
Curtain2	60	60
Curtain3	60	60
Curtain4	60	60
Tunnel	60	60
Inlet	60	60

Curtain Setup tells the controller how fast your curtains and side inlets move. It needs this information to properly calculate automatic inlet advance as well as inlet and curtain positions.

11 Farm Master

11.1 Cold Start

In order to execute a cold start, disconnect the power, then reconnect the power while pressing the 3 buttons of the Farm Master together and hold them for about 3 seconds.

The following will appear:

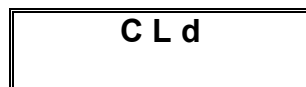

When this screen appears the controller performed a cold start.

CAUTION Cold Start erases all data and history from the memory and load factory defaults!!!

11.2 Set unit number

- Press the two arrow key simultaneously until NO is blinking.
- Set the unit number with the up and down arrows and press Select.

11.3 Main Menu

After activating the **Farm Master** the main screen appears showing the inside average temperature of the rooms. Pressing **SELECT** for 2 seconds enables the user to browse through the main screens' information.

- **trg**: The target temperature for the room (can be changed from the Farm Master itself, only if a curve was not defined).
- **rH**: Humidity in room.
- **rH.t**: Target humidity.
- **day**: Growth day for the room.

The display alternates between the name and the figure.

11.4 Calibration

Temperature sensors are very accurate and most likely will not require calibration. However, if calibration is required it will be done in the following way:

11.4.1 Temperature sensor calibration

1. Use an accurate thermometer reference.
2. Place it near the temperature sensor.
3. Make sure that the inside temperature is stable.
4. Calibrate the temperature sensor immediately after reading.

11.4.2 Calibration procedure

1. In order to get to the calibration menu press “select” and the “up” arrow keys simultaneously and hold them together for about two seconds.
2. The display alternates between the sensor number and the temperature measured.
3. Use the arrow key to change the temperature.
4. Press **SELECT** to move through the sensors and the arrows to change temperatures.

NOTE Calibration of humidity sensor is done exactly the same way; the only difference is that instead of measuring temperature, the humidity is measured by an external humidity sensor.

11.5 Test

The Test Option is used in the installation process and it enables the installer to check systems.

In order to get to the Test Menu, press **Select** and **Down** arrow keys simultaneously and hold them together for about two seconds.

The display alternates between the name of the I/O and an ON/OFF sign.

Pressing the arrow keys allows switching between on and off.

- **rL.1-7**: Relays 1 to 7
- **SPd**: Variable speed. (Check minimum to full capacity using the arrow keys)
- **AO1-4**: Analog outputs 1 to 4
- **t1, t2**: Temperature sensors with the A/D counts blinking on the screen
- **Hu**: humidity sensor A/D counts
- **Ai1-2**: Analog inputs 1 to 2
- **Prs**: Pressure A/D counts
- **DG1-3**: Digital inputs 1 to 3

12 Specifications

Power supply	
Mains voltage single phase	115/230 VAC
Main fuse	315 mA
Secondary fuse	1 A
Maximum power consumption	10 VA
Available power for peripheral equipment	
Analog Inputs	
Three temperature sensors	RTS-2 (THERMISTOR)
Four analog outputs	20mA 0-10V
One humidity sensor input	0-3V
Two analog inputs	0-5V
Digital inputs	
Three digital inputs	Dry contact 5V/2mA
Relays outputs	
Eight normally open power relays	2 HP, 30 Amps, 250 VAC
Housing	
Dimensions (L x W x H)	92.5 x 73 x 36
Ambient climate	
Operating temperature range	0° to + 50° C
Storage temperature range	-10° to + 70° C
Indoor Applications	
The equipment is designed for use in indoor applications only!	

13 Mechanical installation guide

13.1 Sensors and shielded wiring

CAUTION Always connect temperature and sensor shields to earth ground. Avoid mixing high voltage wiring with sensor and low voltage wiring. Keep the controller as far as possible from heavy contactor boxes and other sources of electrical interference.

- For long shielded wires, connect the shield to ground at **one end** only.
- From the ground terminal, run a heavy wire directly to the ground rod. It is acceptable, if necessary, to run the heavy ground wire to the electrical service grounding system rather than directly to the ground rod.

CAUTION Do not use light wires for these ground connections. They must carry heavy lightning currents, sometimes exceeding thousands of amperes. Certainly, do not use the shielding of sensor and low voltage wiring for this purpose.

- Ensure that all ground connections go to a single local point. When lightning strikes, grounds a meter or two apart will be at significantly different voltages. If you have several electronic boxes with individual grounds, connect all these together to a single point (If Possible), preferably to the surge protector ground. This should continue to the ground rod or the electrical service. In particular, avoid grounding any controls remotely through shield wiring.
- Do not use shields to create a path for lightning. For long shield wires, such as building to building runs, connect the shield to ground at **one end** only, to reduce the chance of conducting lightning from one building to another.
- When splicing sensors to longer wires, ensure that the splice is **waterproof**. Use adhesive lined heat shrink (marine grade) to make waterproof connections.
- Use a good compression connector for splicing. This is better than soldering. Do not simply twist wires together and then cover with electrical tape.
- Keep sensor wiring separate from other power distribution and high voltage wiring. Ensure that lightning on other wiring will not transfer to the sensors.
- Install outside temperature sensors so that the sun will not cause false readings, and so that exhaust air from the building will not affect the sensor.

13.2 Installation and electrical connections

- Install computerized electronic controls at least one meter (three feet) away from interference sources such as high voltage wiring to motors, variable speed, light dimmers, relays.
- Install electronic controls in a separate ventilated control room that is protected from extreme temperatures and dirty environments. Place the controls so that the operators can conveniently use the control and read indicators and displays.
- Give your installation a professional appearance, with all wiring in conduit or neatly installed. Keep low voltage wires separate from high voltage wires.
- Use shielded wiring for low level signals. For buried wiring (building to building runs) use high grade jell filled cables that are impervious to moisture.

- Seal cable entry points and control boxes to prevent contamination and corrosion. If you use silicon sealant with acetic acid cure, keep the control open and ventilated until cured. Otherwise, the acetic acid will attack the metal parts, including circuitry.
- Drill cable entry holes on the bottom of the box only.

13.3 Mechanical installation guide

CAUTION *Installation Category (Over voltage Category) II*

CAUTION *The power supply to the controller should be protected by 10 Amps circuit breaker.*

CAUTION *All electrical connections should comply with National Electrical code (NEC)*

1. Open the enclosure lid by unfastening the four screws.
2. Using the provided bag of screws and plastic caps, drill holes in the three designated areas inside the Farm Master. Place caps on the screws once mounting is complete.
3. Drill holes at bottom of the box and place cable holders.
4. Place the required cables through the cable holders at the bottom of the unit. Connect the wires according to the wiring diagrams.
5. Make sure that you use wires large enough for the load of the variable speed.
6. To connect temperature and humidity sensors use shielded two or four conductor #18-#24 gauge cables. Connect the shields to the Ground metal strip. Do not connect the shields to more than one point, or you may induce ground loop currents.
7. Close the Farm Master enclosure lid carefully and tightly. Use RTV silicon or equivalent sealant to seal the cable holders.
8. After installation is completed, operate the Farm Master for a few hours and re- check for proper operation.

13.4 Environmental protection



Recycle raw materials instead of disposing as waste. The controller, accessories and packaging should be sorted for environmental-friendly recycling. The plastic components are labeled for categorized recycling.

13.5 Metal sheet assembly diagram

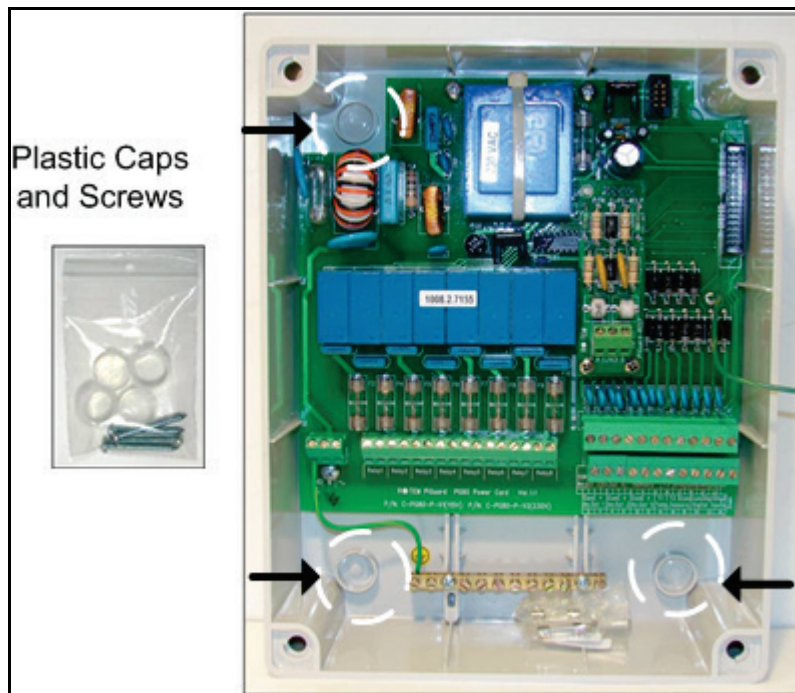

Figure 3: Metal sheet assembly diagram

Instructions

1. Drill holes in the three designated areas located in the back of the controller.
2. Mount the controller using the 3 screws provided in the small plastic bag.
3. Place the provided plastic caps on the screws.

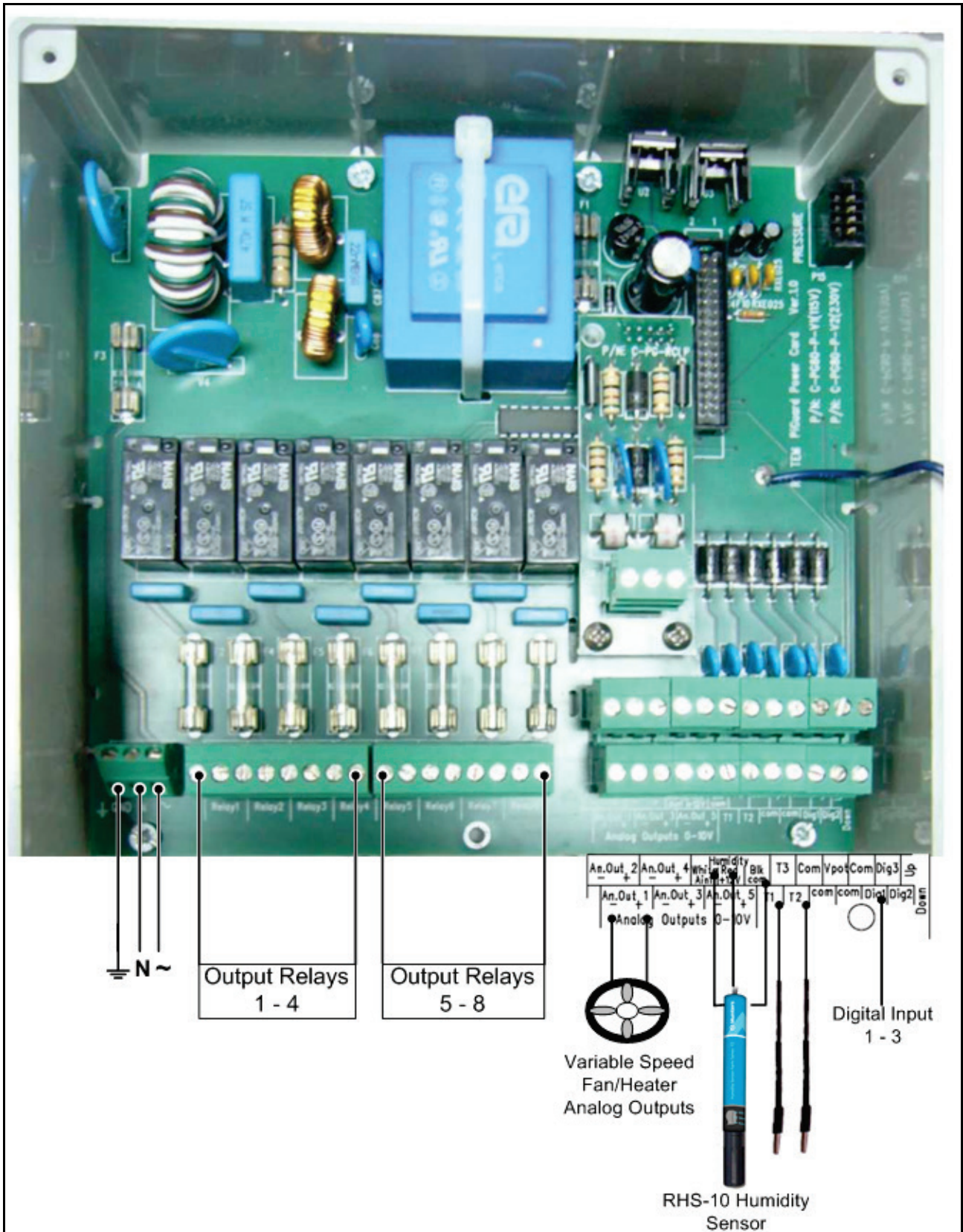

Figure 4: Farm Master Wiring Diagram 1 (Analog Output, Power, Potentiometer, Relays, Variable speed, RHS-2)

13.6 Communication wiring diagrams

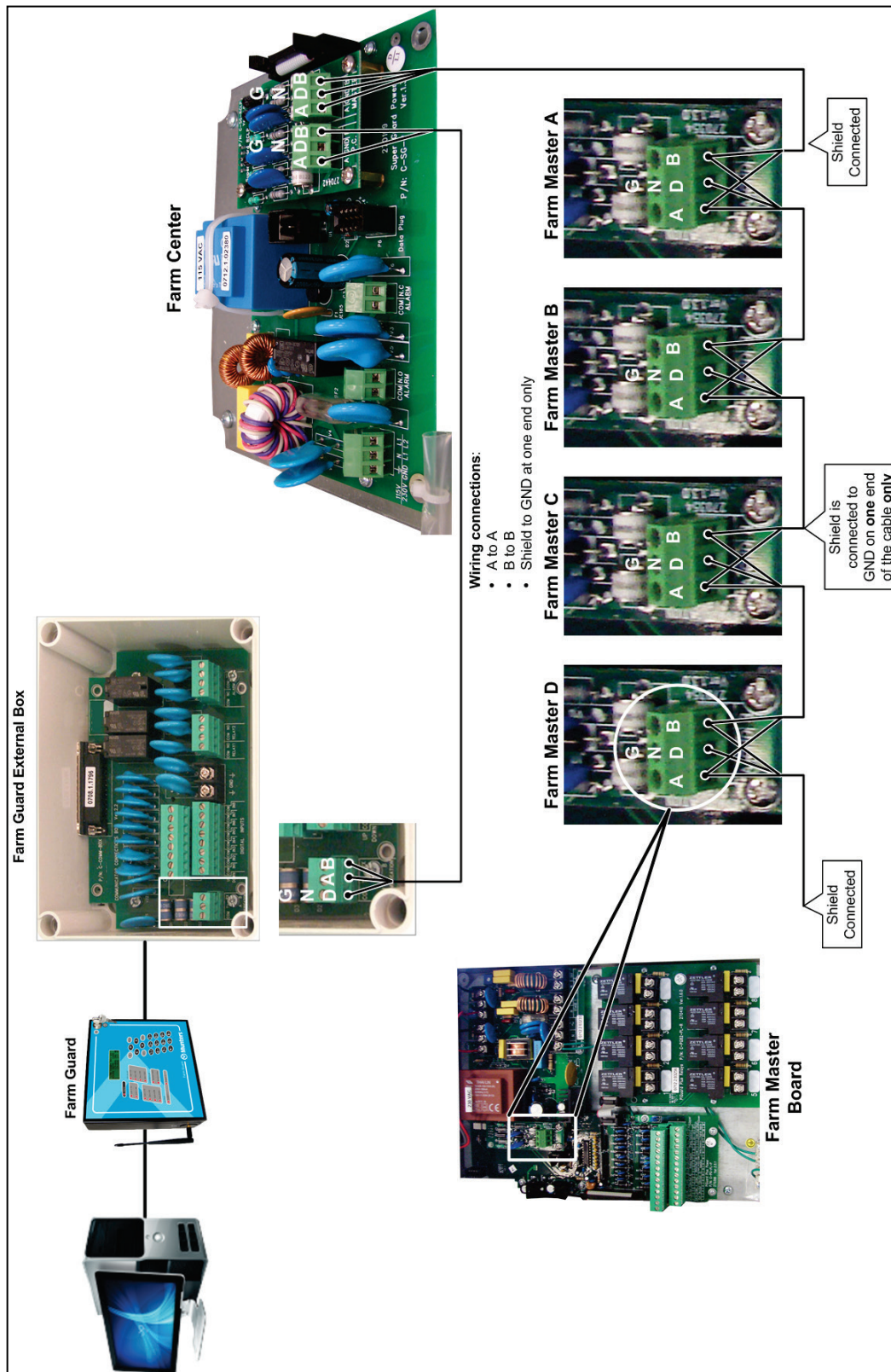

Figure 5: Farm Guard – Farm Center – Farm Master communication

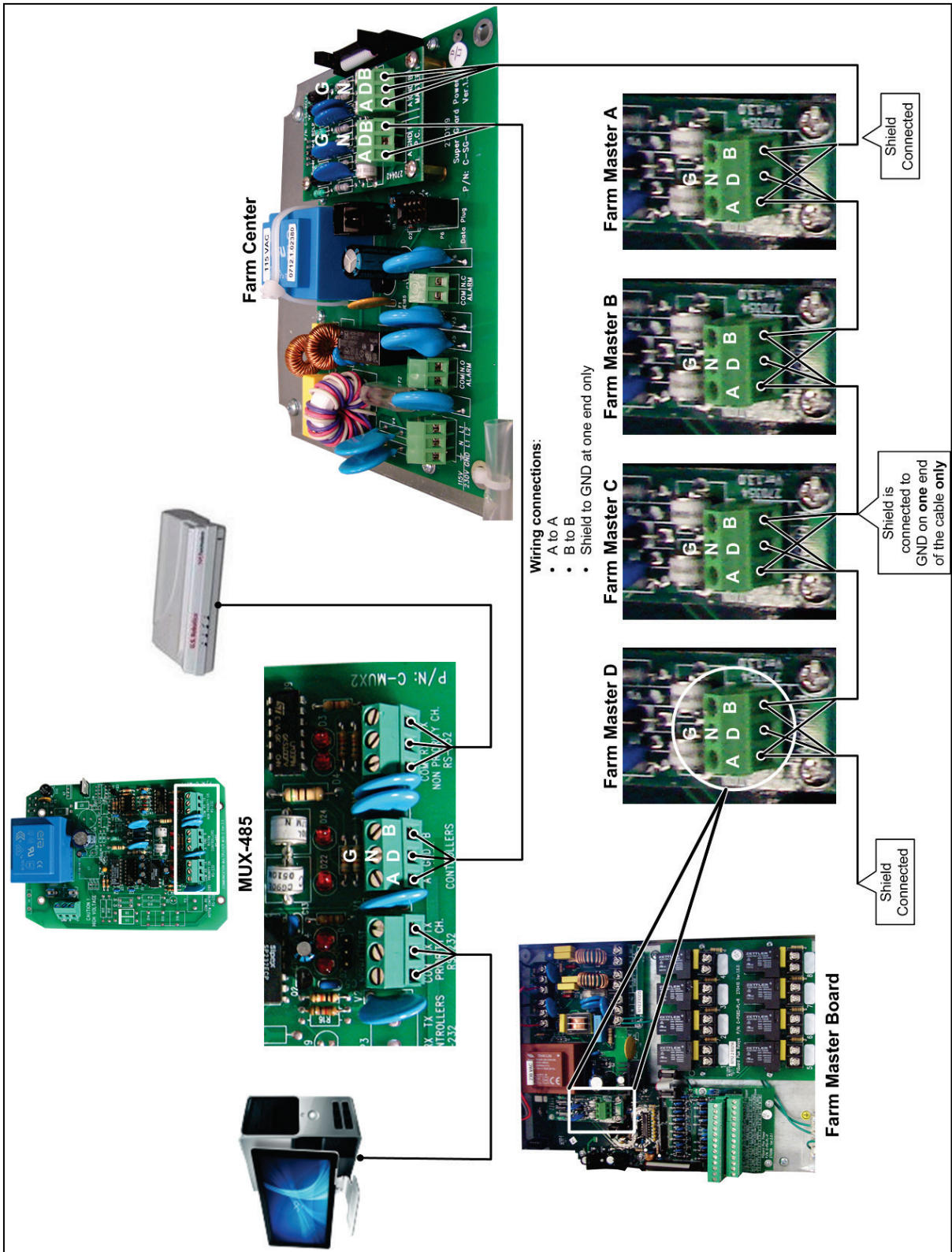

Figure 6: MUX – Farm Center – Farm Master communication

14 Warranty

Warranty and technical assistance

Munters products are designed and built to provide reliable and satisfactory performance but cannot be guaranteed free of faults; although they are reliable products they can develop unforeseeable defects and the user must take this into account and arrange adequate emergency or alarm systems if failure to operate could cause damage to the articles for which the Munters plant was required: if this is not done, the user is fully responsible for the damage which they could suffer.

Munters extends this limited warranty to the first purchaser and guarantees its products to be free from defects originating in manufacture or materials for one year from the date of delivery, provided that suitable transport, storage, installation and maintenance terms are complied with. The warranty does not apply if the products have been repaired without express authorisation from Munters, or repaired in such a way that, in Munters' judgement, their performance and reliability have been impaired, or incorrectly installed, or subjected to improper use. The user accepts total responsibility for incorrect use of the products.

The warranty on products from outside suppliers fitted to Farm Center and Farm Master, (for example antennas, power supplies, cables, etc.) is limited to the conditions stated by the supplier: all claims must be made in writing within eight days of the discovery of the defect and within 12 months of the delivery of the defective product. Munters has thirty days from the date of receipt in which to take action, and has the right to examine the product at the customer's premises or at its own plant (carriage cost to be borne by the customer).

Munters at its sole discretion has the option of replacing or repairing, free of charge, products which it considers defective, and will arrange for their despatch back to the customer carriage paid. In the case of faulty parts of small commercial value which are widely available (such as bolts, etc.) for urgent despatch, where the cost of carriage would exceed the value of the parts, Munters may authorise the customer exclusively to purchase the replacement parts locally; Munters will reimburse the value of the product at its cost price.

Munters will not be liable for costs incurred in demounting the defective part, or the time required to travel to site and the associated travel costs. No agent, employee or dealer is authorised to give any further guarantees or to accept any other liability on Munters' behalf in connection with other Munters products, except in writing with the signature of one of the Company's Managers.

WARNING: In the interests of improving the quality of its products and services, Munters reserves the right at any time and without prior notice to alter the specifications in this manual.

The liability of the manufacturer Munters ceases in the event of:

- dismantling the safety devices;
- use of unauthorised materials;
- inadequate maintenance;
- Use of non-original spare parts and accessories.

Barring specific contractual terms, the following are directly at the user's expense:

- preparing installation sites;
- providing an electricity supply (including the protective equipotential bonding (PE) conductor, in accordance with CEI EN 60204-1, paragraph 8.2), for correctly connecting the equipment to the mains electricity supply;
- providing ancillary services appropriate to the requirements of the plant on the basis of the information supplied with regard to installation;
- tools and consumables required for fitting and installation;
- lubricants necessary for commissioning and maintenance.

It is mandatory to purchase and use only original spare parts or those recommended by the manufacturer.

Dismantling and assembly must be performed by qualified technicians and according to the manufacturer's instructions.

The use of non-original spare parts or incorrect assembly exonerates the manufacturer from all liability.

Requests for technical assistance and spare parts can be made directly to the nearest Munters office. A full list of contact details can be found on the back page of this manual.



www.munters.com

Australia Munters Pty Limited, Phone +61 2 8843 1594, **Brazil** Munters Brasil Industria e Comercio Ltda, Phone +55 41 3317 5050, **Canada** Munters Corporation Mason, Phone +1 517 676 7070, **China** Munters Air Treatment Equipment (Beijing) Co. Ltd, Phone +86 10 80 418 000, **Denmark** Munters A/S, Phone +45 9862 3311, **India** Munters India, Phone +91 20 3052 2520, **Indonesia** Munters, Phone +62 818 739 235, **Italy** Munters Italy S.p.A., Chiusavecchia, Phone +39 0183 52 11, **Japan** Munters K.K., Phone +81 3 5970 0021, **Korea** Munters Korea Co. Ltd., Phone +82 2 761 8701, **Mexico** Munters Mexico, Phone +52 818 262 54 00, **Singapore** Munters Pte Ltd., Phone +65 744 6828, **South Africa and Sub-Sahara Countries** Munters (Pty) Ltd., Phone +27 11 997 2000, **Spain** Munters Spain S.A., Phone +34 91 640 09 02, **Sweden** Munters AB, Phone +46 8 626 63 00, **Thailand** Munters Co. Ltd., Phone +66 2 642 2670, **Turkey** Munters Form Endüstri Sistemleri A.Ş, Phone +90 262 751 37 50, **USA** Munters Corporation Mason, Phone +1 517 676 7070, **Vietnam** Munters Vietnam, Phone +84 8 3825 6838, **Export & Other countries** Munters Italy S.p.A., Chiusavecchia Phone +39 0183 52 11