

User Guide

TrioAir



TrioAir

Ag/MIS/UmGB-2846-10/22 Rev 1.0
P/N: 116875

 Munters

TrioAir Application

User Manual

Rev 1.0, 11/2022

Software Ver:

This manual for use and maintenance is an integral part of the apparatus together with the attached technical documentation.

This document is destined for the user of the apparatus: it may not be reproduced in whole or in part, committed to computer memory as a file or delivered to third parties without the prior authorization of the assembler of the system.

Munters reserves the right to effect modifications to the apparatus in accordance with technical and legal developments.

Index

<i>Chapter</i>		<i>page</i>
1	INTRODUCTION	4
1.1	Disclaimer	4
1.2	Introduction	4
1.3	Notes	4
2	TRIOAIR	5
2.1	Hardware	5
2.1.1	Internet Infrastructure	5
2.1.2	Topology	5
2.2	Network Information	6
2.3	Using Trio Air App and Website	6
2.4	Trio Air Accounts	7
2.4.1	Opening an Account	7
2.4.2	Editing the Page	8
2.5	Pairing a Trio	8
2.6	Users	12
2.6.1	Permission Levels	12
2.6.2	Inviting Users	13
3	WARRANTY	16

1 Introduction

1.1 Disclaimer

Munters reserves the right to make alterations to specifications, quantities, dimensions etc. for production or other reasons, subsequent to publication. The information contained herein has been prepared by qualified experts within Munters. While we believe the information is accurate and complete, we make no warranty or representation for any particular purposes. The information is offered in good faith and with the understanding that any use of the units or accessories in breach of the directions and warnings in this document is at the sole discretion and risk of the user.

1.2 Introduction

Congratulations on your excellent choice of purchasing a Trio Controller!

In order to realize the full benefit from this product it is important that it is installed, commissioned and operated correctly. Before installation or using the controller, this manual should be studied carefully. It is also recommended that it is kept safely for future reference. The manual is intended as a reference for installation, commissioning and day-to-day operation of the Munters Controllers.

1.3 Notes

Date of release: Jan 2020

Munters cannot guarantee to inform users about the changes or to distribute new manuals to them.

All rights reserved. No part of this manual may be reproduced in any manner whatsoever without the expressed written permission of Munters. The contents of this manual are subject to change without notice.

2 TrioAir

The following sections provides information on the hardware requirements as well has how to control and manage your farms via the web.

- Hardware
- Network Information
- Using Trio Air App and Website
- Trio Air Accounts
- Pairing a Trio
- Users

2.1 Hardware

- Internet Infrastructure
- Topology

2.1.1 INTERNET INFRASTRUCTURE

- Required cable: CAT5E or CAT6, shield cable. The cable must be 3 meters/10 feet or less.
- Maximum distance between the Trio and router/switch: 100 meters (330 feet)

NOTE Munters certifies that the communication signal quality is unimpaired up to 100 meters (330 feet).

2.1.2 TOPOLOGY

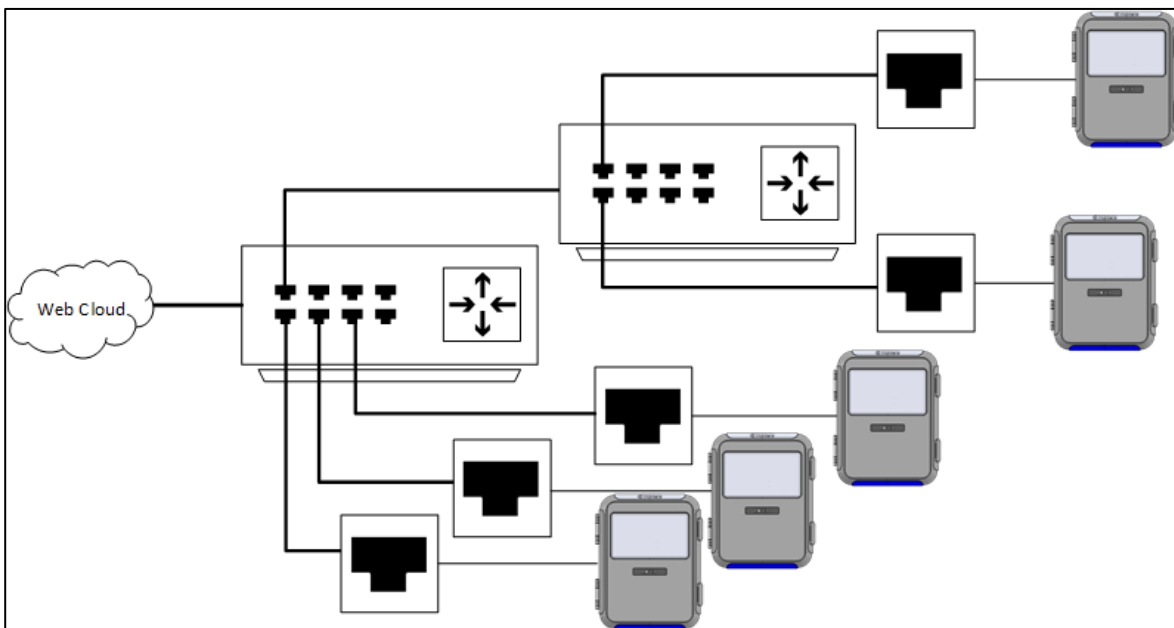



Figure 1: Example topology

- Topology is point to point, from the router. All addressing is automatic.

2.2 Network Information

NOTE All Trio units are mapped automatically to the switch/router.

1. Go to System > General Settings > Network Screen.
2. Click .

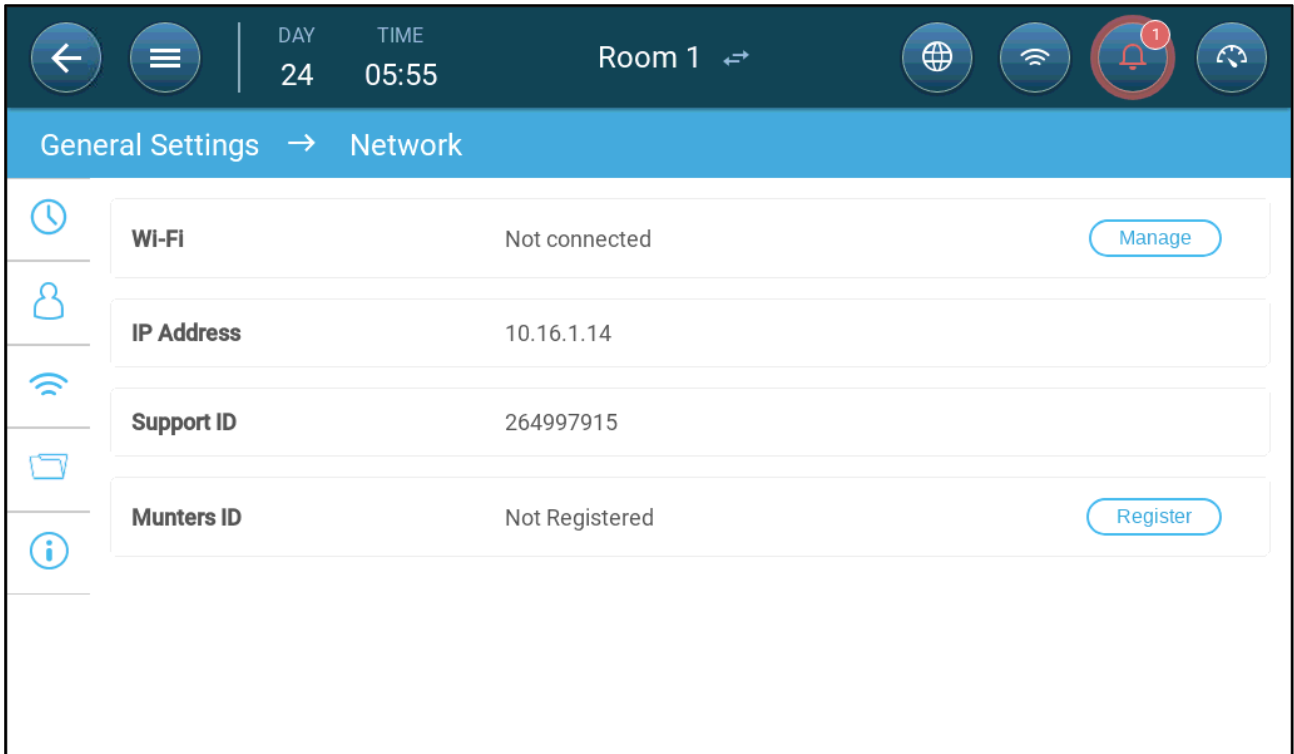

3. Define:

- Wi-Fi: Click **Manage** to enable a Wi-Fi connection.



- Enable Wi-Fi and then select a network.
- IP Address (read only)
- Support ID: Use this address when contacting technical support or when connecting to the Trio via TeamViewer.
- Munters ID: Use this to pair the unit to a farm. Refer to Using Trio Air App and Website.

2.3 Using Trio Air App and Website

The following section describes how to control and manage the units via the Trio Air app or via a web browser. To control the units remotely, perform the following steps:

- Open an account
- Pair units to the account

- Invite users (including assigning permission levels)

2.4 Trio Air Accounts

- Opening an Account
- Editing the Page

2.4.1 OPENING AN ACCOUNT

To manage and control your farm, including all Trio units in these farms, set up an account on the trioair.net website. Once an account is setup, you can manage the farms and users from this site or from the TrioAir app. The process is similar to any standard account opening.

1. Go to www.trioair.net or open the app.

NOTE Munters **strongly** recommends using Google Chrome when going to the www.trio.net page.

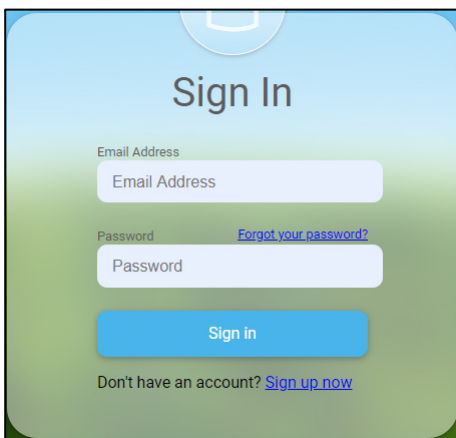

2. Click **Sign Up Now**.

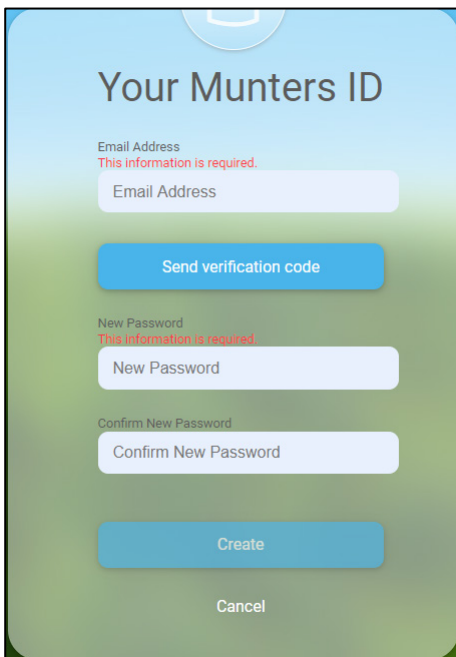

3. Type in your email address and click **Send verification code**. A code is sent to the email address.
4. Type in the verification code that and click Confirm.
5. Type in and confirm your password.

6. Click **Create**.

An account is created.

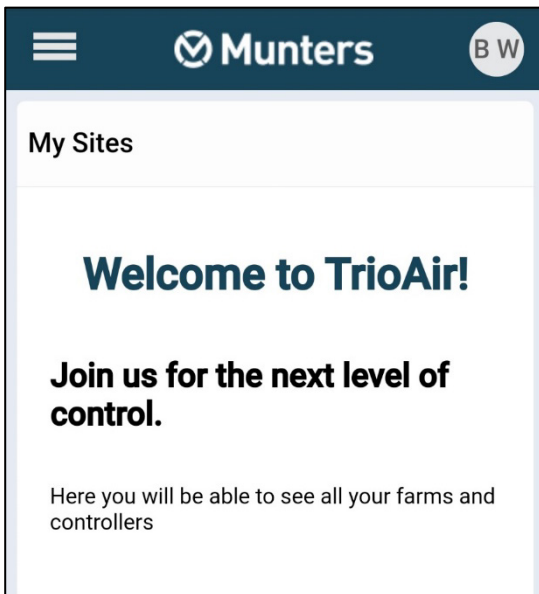

2.4.2 EDITING THE PAGE

- Click the circle in the upper right corner. The following options appears.

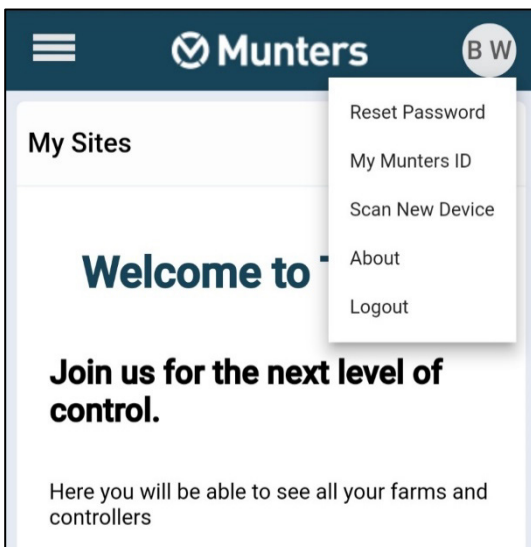

- Reset Password: Change your password.
- My Munters ID: Select this option to edit your email address, how you name appears on the screen, language and unit's preferences. In addition, you can change a PIN code.
- Scan New Device: Used when pairing a Trio unit to the farm. Refer to Pairing a Trio.

NOTE This option is only available when using the app.

- About: When contacting tech support, click this to view the web software version.

2.5 Pairing a Trio

Pairing a Trio unit to an account enables connecting to the unit via the web/app and managing it remotely. Each Trio unit has a unique ID code (a QR code). This code is used to register the device and pair it to an account. This procedure explains how to pair the device to an account.

NOTE Before attempting to register a Trio, verify that the time and date are correctly set (refer to General Settings > User). In the event that the time and date are incorrect, registration is disabled and an error message appears if attempted.

1. Go to System > General Settings > Network .

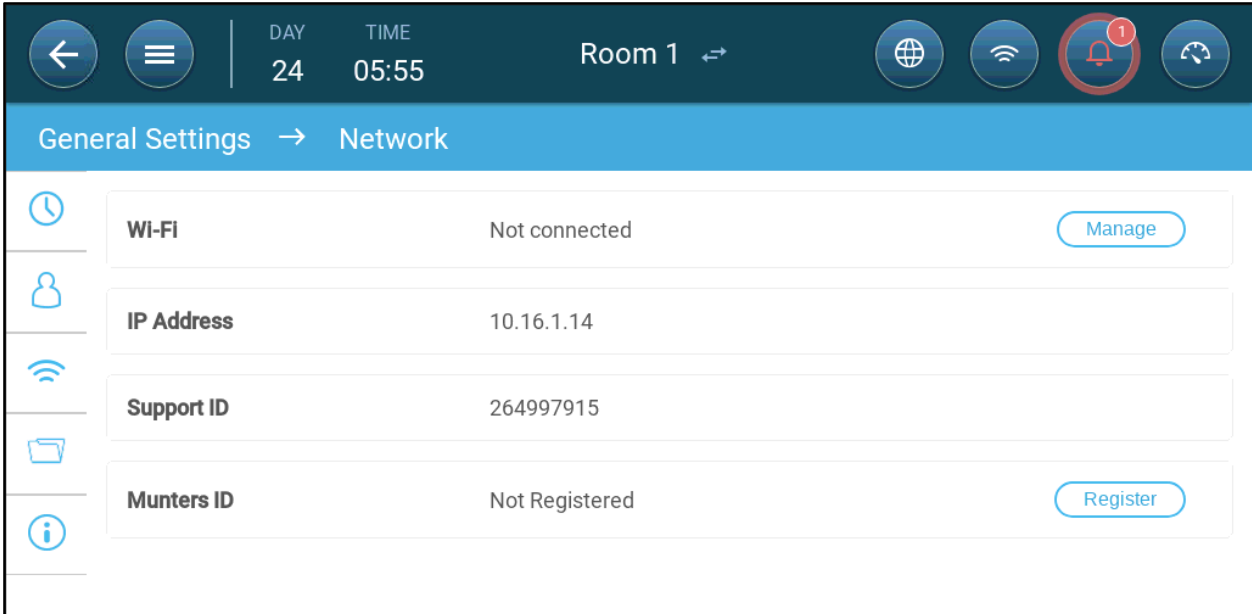

2. Click Register.

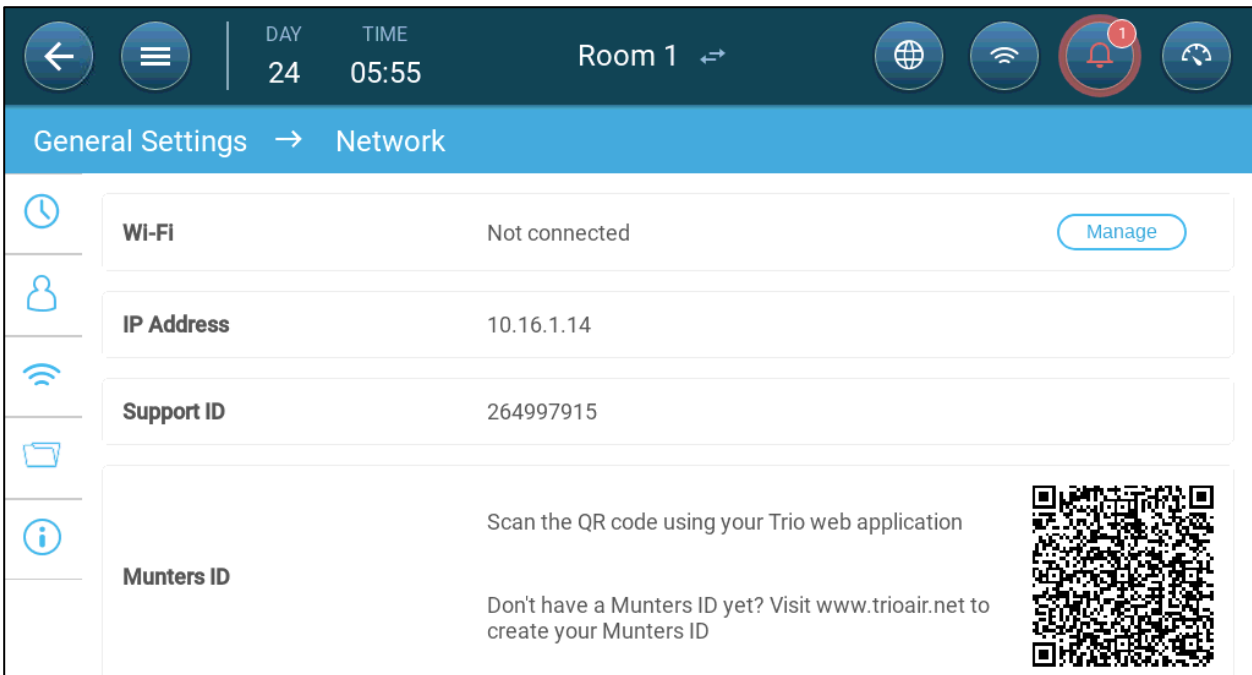

3. Using the TrioAir App (Scan New Device) or a QR reader, scan the QR code. The Trio AIR sign in page appears.

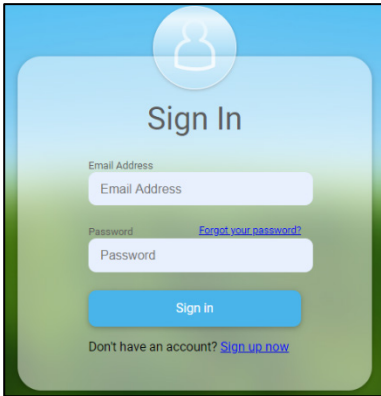

4. Following the online instructions, sign in or create a new account. After signing in, the Trio Air app or web site opens.

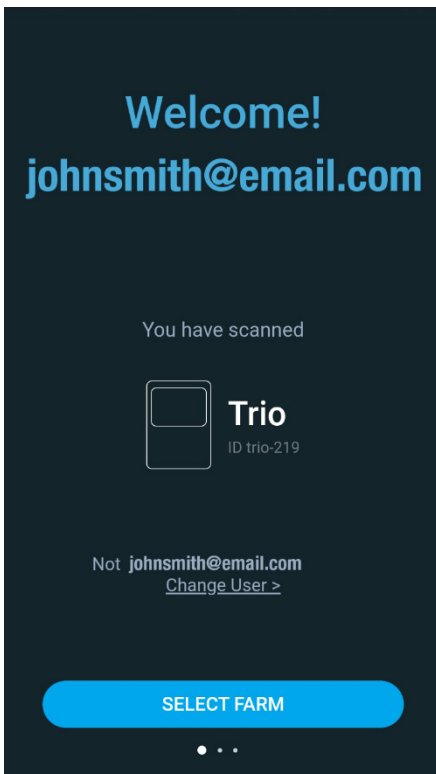

5. Click Select Farm.

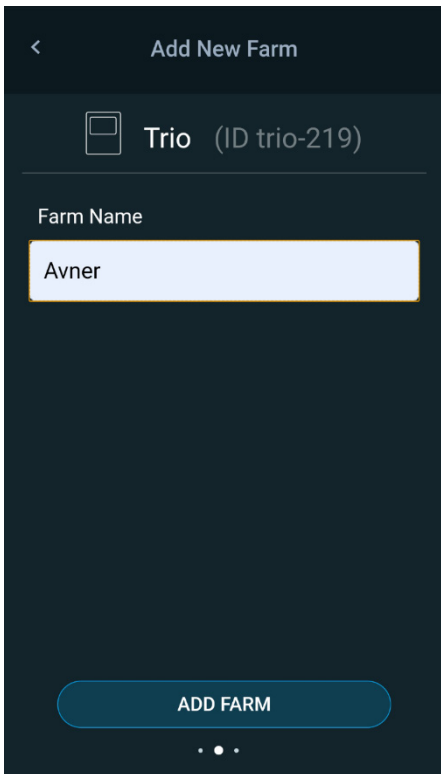

6. Click on an existing account (if there are) or click Add New Farm (follow the online instructions for creating a new farm).

NOTE The person who creates a new farm is automatically defined as the owner. Munters recommends that the person responsible for the farm create the account, and then invite and assign roles to other people.

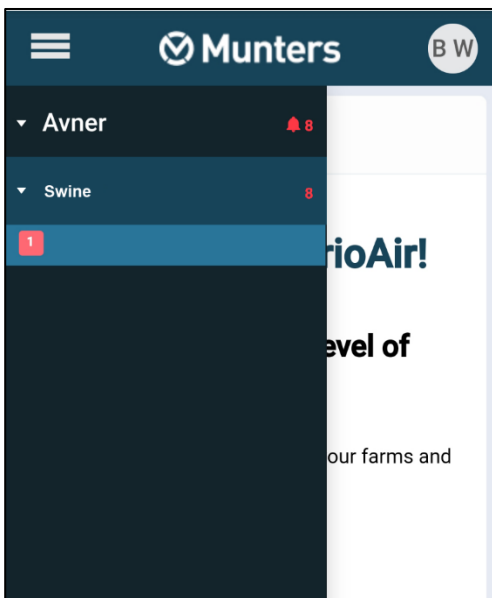

7. Click Register. The Trio unit is now paired with an account.

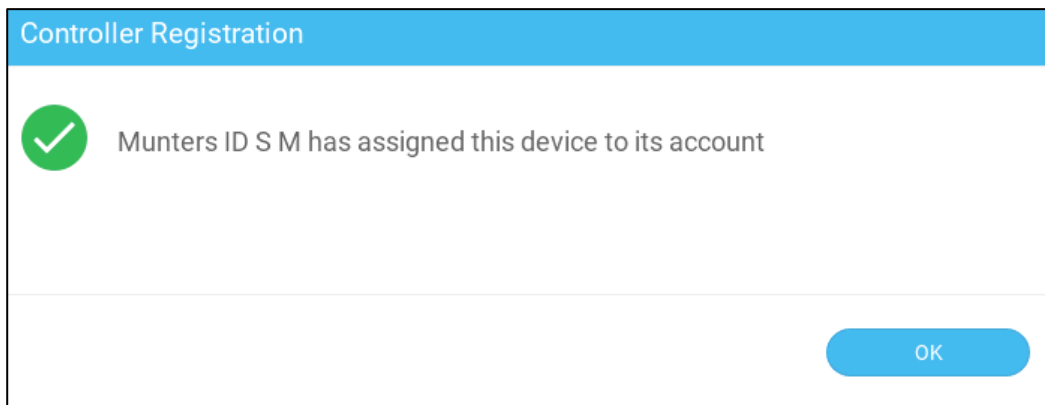

2.6 Users

- Permission Levels
- Inviting Users

2.6.1 PERMISSION LEVELS

There are four permission levels:

- Owner: The person who creates the farm. There can be one owner only. The owner:
 - has full access to and control of all Trio units
 - can invite users and define permission levels
 - disable users/delete/removes
 - view activity status
- Managers have the same capabilities as the owner. There can be multiple managers.
- Operators can manage specific Trio units. An operator does not have access to the Farm Settings function nor can an operator invite users.
- View: View only.

NOTE TrioAir and the webpage cannot be used to map relays and sensors or define the General Settings. Perform these functions locally, on the Trio unit itself.

2.6.2 INVITING USERS

Once a farm is set up, you can invite people to connect to the farm using the Trio Air app (only).

1. Press down on the farm name. The Setting popup appears.

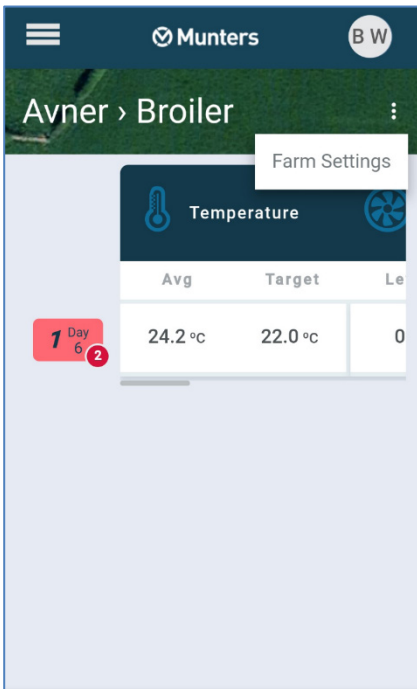

2. Click Settings.



3. Click Invite New User.

4. Type in the invitee's email address and select a role. Click Invite. An email is sent to the address.
 - The invitee must accept the invitation. A confirmation message is then returned to the owner/manager.
 - Once a person accepts the invitation, the user can go to the website or app, see the relevant farms, and perform any permitted operations.
 - An invitation is valid for three days; at that point it expires.
 - An owner can resend an expired invitation.

Once a user accepts the invitation, the user can go to the web site or app and view and manage the farms (according to the user's permission level).



- Click on the room category (Boar 01 in the above picture) to go to the Comparison Page. This page summarizes the rooms' data. Place the cursor the items to view details.

	Temperature		Ventilation		Air Quality			Weight	Animal Management
	Avg	Target	Level		Rh	Co2	Nh3	Avg	Mortality
1 Day 7	△	26.7°C	0%		--	--	--	4.99Kg	0.00%
1	--	--	--	--	--	--	--	--	--
1 Day 13	△	26.7°C	0%		--	--	--	4.99Kg	0.00%
2 Day 7	△	26.7°C	0%		--	--	--	4.99Kg	0.00%
2	--	--	--	--	--	--	--	--	--
2 Day 7	△	26.7°C	0%		--	--	--	4.99Kg	0.00%

3 Warranty

Warranty and technical assistance

Munters products are designed and built to provide reliable and satisfactory performance but cannot be guaranteed free of faults; although they are reliable products they can develop unforeseeable defects and the user must take this into account and arrange adequate emergency or alarm systems if failure to operate could cause damage to the articles for which the Munters plant was required: if this is not done, the user is fully responsible for the damage which they could suffer.

Munters extends this limited warranty to the first purchaser and guarantees its products to be free from defects originating in manufacture or materials for one year from the date of delivery, provided that suitable transport, storage, installation and maintenance terms are complied with. The warranty does not apply if the products have been repaired without express authorisation from Munters, or repaired in such a way that, in Munters' judgement, their performance and reliability have been impaired, or incorrectly installed, or subjected to improper use. The user accepts total responsibility for incorrect use of the products.

The warranty on products from outside suppliers fitted to Trio, (for example antennas, power supplies, cables, etc.) is limited to the conditions stated by the supplier: all claims must be made in writing within eight days of the discovery of the defect and within 12 months of the delivery of the defective product. Munters has thirty days from the date of receipt in which to take action, and has the right to examine the product at the customer's premises or at its own plant (carriage cost to be borne by the customer).

Munters at its sole discretion has the option of replacing or repairing, free of charge, products which it considers defective, and will arrange for their despatch back to the customer carriage paid. In the case of faulty parts of small commercial value which are widely available (such as bolts, etc.) for urgent despatch, where the cost of carriage would exceed the value of the parts, Munters may authorise the customer exclusively to purchase the replacement parts locally; Munters will reimburse the value of the product at its cost price.

Munters will not be liable for costs incurred in demounting the defective part, or the time required to travel to site and the associated travel costs. No agent, employee or dealer is authorised to give any further guarantees or to accept any other liability on Munters' behalf in connection with other Munters products, except in writing with the signature of one of the Company's Managers.

WARNING: In the interests of improving the quality of its products and services, Munters reserves the right at any time and without prior notice to alter the specifications in this manual.

The liability of the manufacturer Munters ceases in the event of:

- dismantling the safety devices;
- use of unauthorised materials;
- inadequate maintenance;
- use of non-original spare parts and accessories.

Barring specific contractual terms, the following are directly at the user's expense:

- preparing installation sites;
- providing an electricity supply (including the protective equipotential bonding (PE) conductor, in accordance with CEI EN 60204-1, paragraph 8.2), for correctly connecting the equipment to the mains electricity supply;
- providing ancillary services appropriate to the requirements of the plant on the basis of the information supplied with regard to installation;
- tools and consumables required for fitting and installation;
- lubricants necessary for commissioning and maintenance.

It is mandatory to purchase and use only original spare parts or those recommended by the manufacturer.

Dismantling and assembly must be performed by qualified technicians and according to the manufacturer's instructions.

The use of non-original spare parts or incorrect assembly exonerates the manufacturer from all liability.

Requests for technical assistance and spare parts can be made directly to the nearest [Munters office](#).

