

Smart C/D

Manual for use and maintenance



Smart C and Smart D

Climate Controller

Ag/MIS/UmGb-2617-07/18 Rev 1.0

P/N: 116084

 **Munters**

Smart C and Smart D

Manual for use and maintenance

Revision: N1.0 of 03.2019

Ag/MIS/UmGb-2617-07/18 Rev 3.0 (MIS)

Product Software: Version 2.05

This manual for use and maintenance is an integral part of the apparatus together with the attached technical documentation.

This document is destined for the user of the apparatus: it may not be reproduced in whole or in part, committed to computer memory as a file or delivered to third parties without the prior authorization of the assembler of the system.

Munters reserves the right to effect modifications to the apparatus in accordance with technical and legal developments.

Index

<i>Chapter</i>		<i>page</i>
1	INTRODUCTION	5
1.1	Disclaimer	5
1.2	Introduction	5
1.3	Notes	5
2	SAFETY ASPECTS	6
2.1	Grounding	6
2.2	Filtering	6
2.3	Checking the battery level	6
2.4	Frequency inverters	6
3	BEFORE USING	8
3.1	Smart layouts	8
3.1.1	Smart 4C/4CV Layout	8
3.1.2	Smart 8C/8CV Layout	8
3.1.3	Smart 10D/10DV Layout	9
3.2	Smart interface	10
3.2.1	User interface	10
3.2.2	Hot keys	10
3.2.3	Cold start	11
3.3	Menu structure	11
3.4	General features	11
3.5	Alarms	12
4	INSTALLATION	13
4.1	Mains voltage connections	13
4.2	Smart C Wiring	13
4.3	Smart 10D Wiring	19
5	USING THE SMART	24
5.1	Temperature menu	24
5.1.1	No Temperature Curve	24
5.1.2	Two Point Temperature Curve	24
5.1.3	Four Point Temperature Curve	24
5.1.4	Automatic temperature adjustment example	25
5.2	Humidity menu	26

5.2.1	Humidity treatment.....	26
5.2.2	How is humidity treatment performed?.....	26
5.3	Minimum ventilation menu -----	27
5.3.1	No ventilation curve	27
5.3.2	Two point ventilation curve.....	27
5.3.3	Four point ventilation curve	27
5.4	Alarms menu -----	28
5.5	Growth day menu -----	28
5.6	Test menu -----	29
5.7	Calibration menu -----	29
5.7.1	Calibration of curtains using potentiometers	30
5.7.2	Calibration of curtains without potentiometers	30
5.8	System menu -----	30
5.9	Additional functions -----	31
5.9.1	Light function	31
5.9.2	General timer.....	32
6	COOLING AND HEATING FUNCTIONS-----	33
6.1	Cooling Functions-----	33
6.1.1	Variable fan	33
6.1.2	Minimum ventilation cycle fan.....	35
6.1.3	On/Off fan	36
6.1.4	Natural ventilation	37
6.1.5	Curtain.....	38
6.1.6	Air inlet.....	39
6.1.7	Cool parameters.....	40
6.2	Heating functions -----	41
6.2.1	Variable heat	41
6.2.2	Floor heat.....	42
6.2.3	Room heat.....	42
7	TECHNICAL DATA -----	44
8	ELECTRICAL GROUNDING FOR CONTROLLERS -----	45
8.1	Ground rods -----	45
8.2	Ground wire-----	46
8.3	Ground clamps-----	46
8.4	What should be grounded? -----	46
9	TROUBLESHOOTING -----	47
10	WARRANTY -----	49

1 Introduction

1.1 Disclaimer

Munters reserves the right to make alterations to specifications, quantities, dimensions etc. for production or other reasons, subsequent to publication. The information contained herein has been prepared by qualified experts within Munters. While we believe the information is accurate and complete, we make no warranty or representation for any particular purposes. The information is offered in good faith and with the understanding that any use of the units or accessories in breach of the directions and warnings in this document is at the sole discretion and risk of the user.

1.2 Introduction

Congratulations on your excellent choice of purchasing a Smart!
In order to realize the full benefit from this product it is important that it is installed, commissioned and operated correctly. Before installation or using the fan, this manual should be studied carefully. It is also recommended that it is kept safely for future reference. The manual is intended as a reference for installation, commissioning and day-to-day operation of the Munters Controllers.

1.3 Notes

Date of release: April 2009

Munters cannot guarantee to inform users about the changes or to distribute new manuals to them. All rights reserved. No part of this manual may be reproduced in any manner whatsoever without the expressed written permission of Munters. The contents of this manual are subject to change without notice.

2 Safety aspects

2.1 Grounding

- Always connect temperature and sensor shields to earth ground. Avoid mixing high voltage wiring with sensor and low voltage wiring.
- Keep the controller as far as possible from heavy contactor boxes and other sources of electrical interference.
- Do not connect communication wire shields, which go from one house to another at both ends. Connect them at one end only. Connection at both ends can cause ground loop currents to flow, which reduce reliability.
- The COM connection for communications is not the shield wire. The COM, RX and TX wires must connect to each other at all controllers.

2.2 Filtering

If this installation includes a power inverter to drive variable speed fans, install an EMI filter in front of the inverter, according to the specifications provided by the inverter manufacturer. Refer to the inverter documentation.

2.3 Checking the battery level

Check the battery once a year. The output must be 2.7 volts (minimum). Authorized personnel only must replace the battery if the output is below the minimum required level or every five years.

2.4 Frequency inverters

Frequency inverters can cause severe electrical and electromagnetic interference. Therefore, when employing a frequency inverter, it is critical that you carefully follow the manufacturer's installation instructions. In particular verify:

- that the cable shielding between the inverter and any motor meets industry standards
- proper grounding of the inverter's chassis and motor power cable
- proper grounding of low voltage cable shield wire
- that the controller and inverter cables are kept in separate conduits or wire bundles

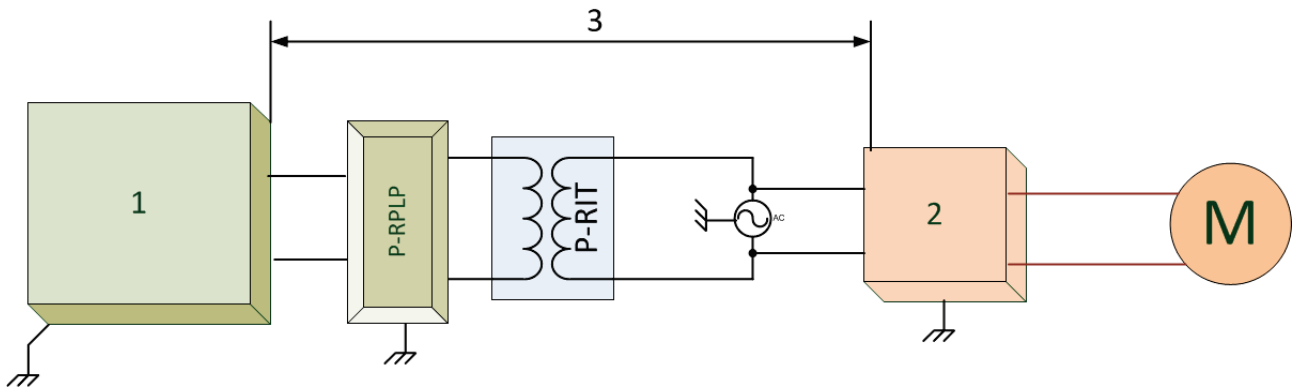

1. Controller
2. Inverter
3. Place the controller at least five meters from the inverter

3 Before using

The following section provides an introduction to the Smart Units, which provides advanced environmental control for small applications. The Smart controllers provide a comprehensive solution for growers seeking a low cost solution without sacrificing quality. Smart gives you control over the temperature and humidity in buildings using intelligent, user-friendly climate control software.

- Smart layouts
- Smart interface
- Menu structure
- General features
- Alarms

3.1 Smart layouts

The Smart layout depends on the model. The following sections detail the relays and outputs layouts.

- Smart 4C/4CV Layout
- Smart 8C/8CV Layout
- Smart 10D/10DV Layout

3.1.1 Smart 4C/4CV Layout

Relay	Options				
1	• None	• Floor heat	• MV Fan 1		
2	• None	• Room heat	• MV Fan 2		
3	• None	• Cooling	• ON/OFF Fan 3		
4	• None	• Alarm	• ON/OFF Fan 4		
	• Options				
Output	• 4C		• 4CV		
TRIAC	• None		• Variable Fan 1		
Analog Output 1	• None	• Variable Fan	• None	• Inlet	• Variable Fan 2
Analog Output 2	• None	• Variable Heat	• None		• Variable Heat

3.1.2 Smart 8C/8CV Layout

Relay	Options		
1	• None	• Floor heat 2	• MV Fan 1

Relay	Options				
2	<ul style="list-style-type: none"> None Room heat 3 	<ul style="list-style-type: none"> MV Fan 2 	<ul style="list-style-type: none"> Timer 1 	<ul style="list-style-type: none"> Light 	
3	<ul style="list-style-type: none"> None 	<ul style="list-style-type: none"> Cooling 	<ul style="list-style-type: none"> ON/OFF Fan 5 		
4	<ul style="list-style-type: none"> None 	<ul style="list-style-type: none"> Curtain 1 open 	<ul style="list-style-type: none"> ON/OFF Fan 6 		
5	<ul style="list-style-type: none"> None 	<ul style="list-style-type: none"> Curtain 1 close 	<ul style="list-style-type: none"> ON/OFF Fan 7 		
6	<ul style="list-style-type: none"> None 	<ul style="list-style-type: none"> Curtain 2 open 	<ul style="list-style-type: none"> ON/OFF Fan 3 	<ul style="list-style-type: none"> Timer 2 	
7	<ul style="list-style-type: none"> None 	<ul style="list-style-type: none"> Curtain 2 close 	<ul style="list-style-type: none"> ON/OFF Fan 4 	<ul style="list-style-type: none"> Timer 3 	
8	<ul style="list-style-type: none"> None 		<ul style="list-style-type: none"> Alarm 		
	<ul style="list-style-type: none"> Options 				
Output	<ul style="list-style-type: none"> 8C 		<ul style="list-style-type: none"> 8CV 		
TRIAC	<ul style="list-style-type: none"> None 		<ul style="list-style-type: none"> Variable Fan 1 		
Analog Output 1	<ul style="list-style-type: none"> None 	<ul style="list-style-type: none"> Variable Fan 1 	<ul style="list-style-type: none"> None 	<ul style="list-style-type: none"> Inlet 	<ul style="list-style-type: none"> Variable Fan 2
Analog Output 2	<ul style="list-style-type: none"> None 	<ul style="list-style-type: none"> Variable Heat 	<ul style="list-style-type: none"> Variable Fan 2 	<ul style="list-style-type: none"> None 	<ul style="list-style-type: none"> Variable Heat

3.1.3 Smart 10D/10DV Layout

Relay	Options				
1	<ul style="list-style-type: none"> None 	<ul style="list-style-type: none"> Floor heat 2 	<ul style="list-style-type: none"> MV Fan 1 		
2	<ul style="list-style-type: none"> None Room heat 3 	<ul style="list-style-type: none"> MV Fan 2 	<ul style="list-style-type: none"> Timer 1 		
3	<ul style="list-style-type: none"> None 	<ul style="list-style-type: none"> Cooling 	<ul style="list-style-type: none"> ON/OFF Fan 5 		
4	<ul style="list-style-type: none"> None 	<ul style="list-style-type: none"> Curtain 1 open 	<ul style="list-style-type: none"> ON/OFF Fan 6 		
5	<ul style="list-style-type: none"> None 	<ul style="list-style-type: none"> Curtain 1 close 	<ul style="list-style-type: none"> ON/OFF Fan 7 		
6	<ul style="list-style-type: none"> None 	<ul style="list-style-type: none"> Curtain 2 open 	<ul style="list-style-type: none"> ON/OFF Fan 3 	<ul style="list-style-type: none"> Timer 2 	
7	<ul style="list-style-type: none"> None 	<ul style="list-style-type: none"> Curtain 2 close 	<ul style="list-style-type: none"> ON/OFF Fan 4 	<ul style="list-style-type: none"> Timer 3 	
8	<ul style="list-style-type: none"> None 		<ul style="list-style-type: none"> ON/OFF Fan 8 		
9	<ul style="list-style-type: none"> None 	<ul style="list-style-type: none"> ON/OFF Fan 9 	<ul style="list-style-type: none"> Light 		
10	<ul style="list-style-type: none"> None 		<ul style="list-style-type: none"> Alarm 		
	Options				
Output	<ul style="list-style-type: none"> 10D 		<ul style="list-style-type: none"> 10DV 		
TRIAC	<ul style="list-style-type: none"> None 		<ul style="list-style-type: none"> Variable Fan 1 		
Analog Output 1	<ul style="list-style-type: none"> None 	<ul style="list-style-type: none"> Variable 	<ul style="list-style-type: none"> None 	<ul style="list-style-type: none"> Inlet 	<ul style="list-style-type: none"> Variable

Relay	Options			
		Fan		Fan 2
Analog Output 2	• None	• Variable Heat	• None	• Variable Heat

3.2 Smart interface

- User interface
- Hot keys
- Cold start

3.2.1 User interface

- **LED indicator:** ON/OFF state of LED indicates whether the relay is operating or idle.
- **<P> key:** Serves to navigate to the parameters in main menus and edit parameters (press once to enter edit mode, press again to exit edit mode).
- **Down / Up arrow keys:** Serve to increase/decrease parameter values, navigate Hot Keys (see **Hot Keys** section) and menus.
- **<OK> key:** Navigates in and out of main screen and menus (Press once to enter main menus, press again to exit).

3.2.2 Hot keys

The Smart incorporates keys enabling quick access to different parameters. On the Main screen, press the ▼▲ keys. The following hot keys are displayed.

Table 1: Smart Hot Keys

Hot Key	Description
T Day	Current temperature and growth day
Wind-D	Current wind direction
F#1/F#2	Fan 1 and Fan 2 minimum and maximum variable fan speed
Feed	Current amount of feed in augury
Water	Amount of water distributed
C1/C2	Curtain 1/Curtain 2 current position
Cycle	Minimum cycling on or off. If on, current ventilation speed
Var Heat:	Current percentage of maximum heating
V. Fan-1	Current percentage of maximum fan speed
Min	Current minimum ventilation level and target temperature
Out Temp	Outside temperature
RH / HT	Current relative humidity / Is humidity treatment currently running

F#1 and F#2 displays depend on:

- Presence of a TRIAC or analog output defined as a variable fan (refer to Smart Layouts, page 8)
- Variable Fan Cycle definition (refer to Variable fan, page 33).
- Defined as cycle: The hot key displays the defined minimum and maximum variable fan levels. These numbers always remain the same.
- Defined as speed: The hot key displays the current minimum and maximum variable fan levels. These numbers change according to the curve.

NOTE: Version 2.05 supports F#1/F#2.

3.2.3 Cold start

Cold Start procedure resets the controller to its original factory settings. Perform a Cold Start after software version replacement, reinstallation or when instructed by Munters' electrician.

- To perform cold start, press the following keys simultaneously after reconnecting power:



NOTE: Cold Start the controller automatically goes into the SYSTEM menu. Click **OK** to go to the main menu.

3.3 Menu structure

- The Main screen is in the root, the main menus are on the next line. In order to return to the main screen at any point, press and hold **OK**.
- To reach a main menu (the level below the Main screen), press the **OK** key.
- To reach any level below the main menus, press **P**.

For example, to view information of **HUM DELAY (m)** from the main screen, the following keys should be pressed: **OK > TARGET HUM >P**, until the desired parameter is displayed.

- **X** represents a number. For example, **Growth Day: xxx** means a specific growth day number, such as the 9th day.
- Menu items:
 - Temperature
 - Min Vent
 - Alarms
 - Test
 - System
 - Humidity
 - Settings
 - Growth Day
 - Calibration

NOTE: The Target Humidity appears **ONLY** if a humidity sensor has been installed.

3.4 General features

- To change the Main screen display, click the last Hot Key.
- If a screen other than the Main screen is being displayed for five consecutive minutes, the system returns to the Main screen display automatically (in menus only, not including hot keys).

- When a value is being modified with the arrow keys (either ▲ or ▼), the changes occur at a rate of 2 changes per second. After holding down an arrow key for 3 seconds, the changes occur at a rate of 10 changes per second.
- If the system displays one of the Hot Keys and no alarms arise, the screen is refreshed every second. If the system displays a Hot Key screen and alarms arise, both the Hot Key screen and the alarm are displayed alternately every three seconds. If more than one alarm is activated, the Hot Key screen displays the different alarms alternately.

3.5 Alarms

Table 1 shows the list of alarms. The alarms can be viewed on the main screen. The main screen shows the alarms and the main screen display alternately. Smart navigates between alarms automatically.

Table 2: Alarm Messages

Alarm Display	Explanation	Possible Alarm Reason
T1 SNS ERR	Error in Temp sensor 1	Temp sensor number 1 is either out of order, disconnected or shorted
T2 SNS ERR	Error in Temp sensor 2	Temp sensor number 2 is either out of order, disconnected or shorted
T3 SNS ERR	Error in Temp sensor 3	Temp sensor number 3 is either out of order, disconnected or shorted
HUM SNS ERR	Error in Humidity sensor	Humidity sensor number 1 is either out of order or disconnected
HI TEMP	High Temperature	The average temperature in the building is higher than the temperature set as the alarm's temperature.
LOW TEMP	Low Temperature	The average temperature in the building is lower than the temperature set as the alarm's temperature.
CURTAIN 1 FAIL	Curtain is not moving properly	<ul style="list-style-type: none"> • Cable is disconnected • Curtain potentiometer is faulty • Curtain's motor is not working properly
CURTAIN 2 FAIL	Curtain is not moving properly	<ul style="list-style-type: none"> • Cable is disconnected • Curtain potentiometer is faulty • Curtain's motor is not working properly

- Reset alarm relay by pressing **OK** on the main menu. The alarm messages continue to be displayed until the problem is resolved.
- If a sensor was deliberately removed, the sensor error alarm can be disabled via the Calibration menu (see Calibration menu).

4 Installation

The following sections details the installation and wiring procedures.

CAUTION *If any problem arises with the hardware, do not open the box. Contact an authorized electrician.*

- Mains voltage connections, page 13
- Smart C Wiring, page 13
- Smart D Wiring, page 19

4.1 Mains voltage connections

The input power of the controller should be connected to one or a few circuit breakers in the electrical enclose (fuse box).

- **Single wire supply:** Munters recommends this supply for applications in which the controller's outputs are connected to low power contactors. In this case one 18 AWG cable should be used for the Phase and for the Neutral.
- **Multi wire supply:** Munters recommends this supply for high power applications in which the outputs supply up to 5 Amp each. In this case a separate 18 AWG wire should be connected from each circuit breaker in the electrical enclose (fuse box) to each output, and to the variable speed fan. All the wires (from the separate circuit breakers) are from the same single phase.

WARNING! *Multi wire supply! Up to nine independent mains input may be present in Smart. Be sure that all appropriate circuit breakers are in the off position before servicing.*

4.2 Smart C Wiring

- Figure 1: Smart C Board Layout
- Figure 2: Smart C Wiring Diagram of Low Voltage Section
- Figure 3: Smart C Wiring Diagram of Main Voltage Section (No Filter) and Protection
- Figure 4: Smart C Wiring Diagram of Main Voltage Section (No Filter) having Protection and Isolation
- Figure 5: Smart C Wiring Diagram of Main Voltage Section Showing Filtering
- Figure 6: Smart C Communication RS-232 Wiring Diagram
- Figure 7: Smart C Communication RS-485Wiring Diagram

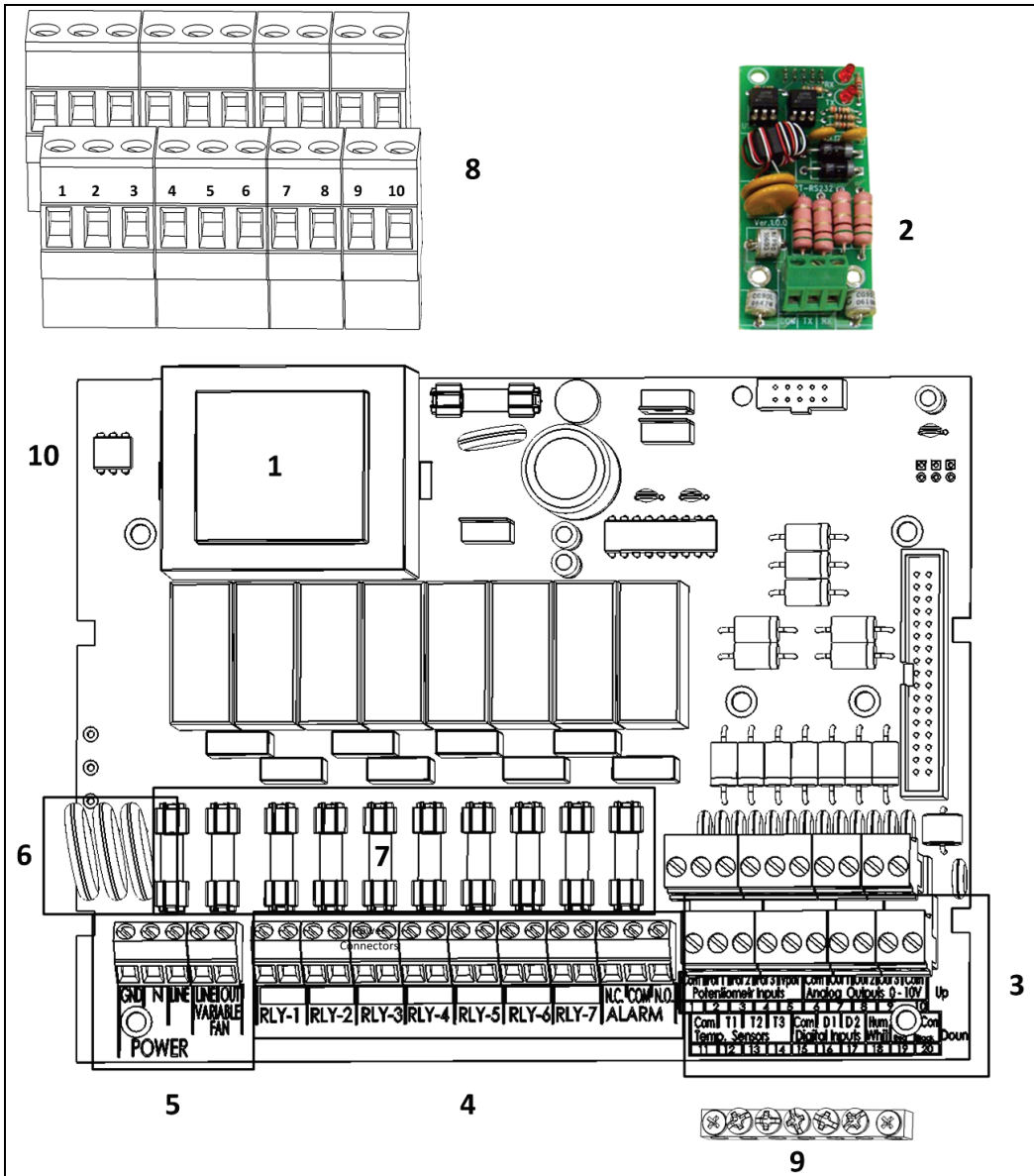

Figure 1: Smart C Board Layout

Figure 1 key	
1: Transformer	2: Communication card
3: Low voltage ports	4: Relay ports
5: Power ports	6: Input lighting protection
7: Fuses	8: Open the metal plate in a terminal before inserting the cable.
9: Ground strip	TRIAC
Communication Card part numbers: P-SMART-RS232 / P-SMART-RS485	

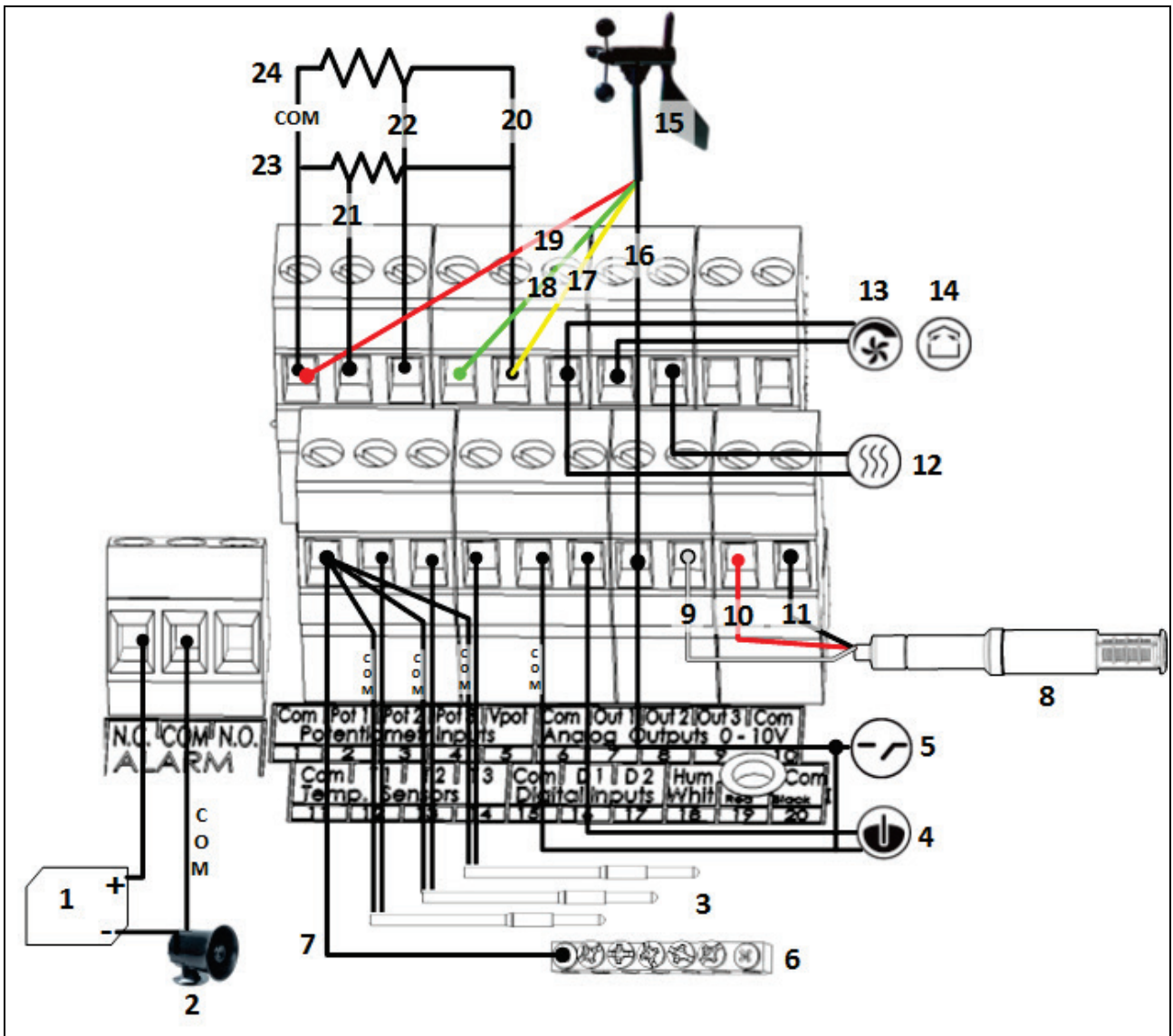

Figure 2: Smart C Wiring Diagram of Low Voltage Section

Figure 2 key

1: 12V battery	2: Alarm	3: RTS-2 temperature sensors
4: Water meter	5: Food meter	6: Ground strip
7: Shield wire	8: Humidity sensor	9: White wire
10: Red wire	11: Black wire	12: Variable heater
13: Variable fan	14: Inlet	15: Wind direction / speed
16: Black wire	17: Yellow wire	18: Green wire
19: Red wire	20: VPot	21: Potentiometer 1
22: Potentiometer 2	23: Curtain 1	24: Curtain 2

NOTE: The alarm relay can be either NC or NO (normally used for either an alarm system or a dialer.

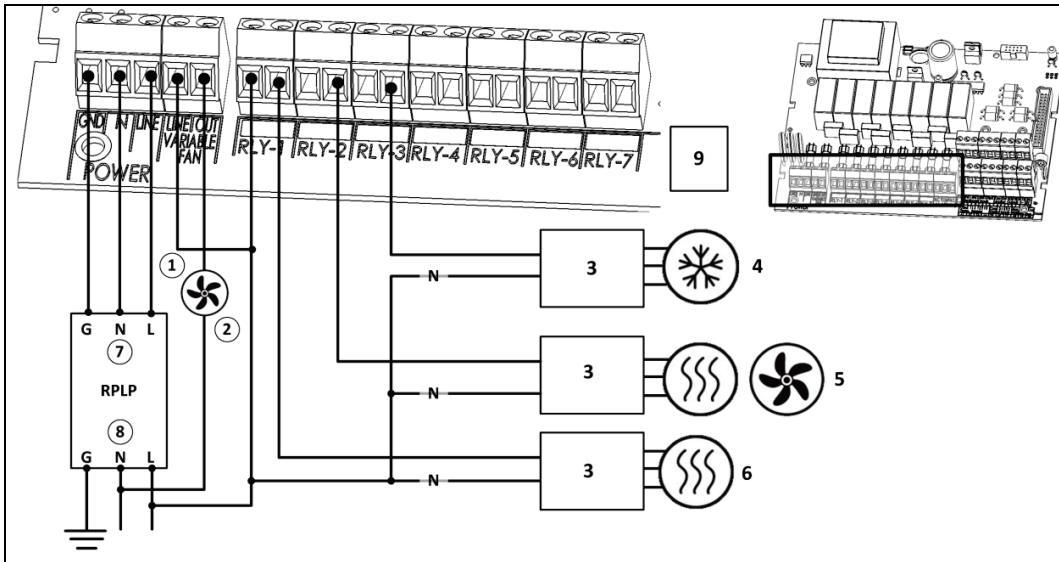

Figure 3: Smart C Wiring Diagram of Main Voltage Section (No Filter) and Protection

Figure 3 key

1	Variable fan	6	Heat 2
2	Only TRIAC versions support direct single phase fan connectivity	7	Input
3	Three phase contactor	8	Output
4	Cooler	9	The devices shown here are examples only. Actual devices installed differ in actual installments.
5	Fan 2 or Heater 3		

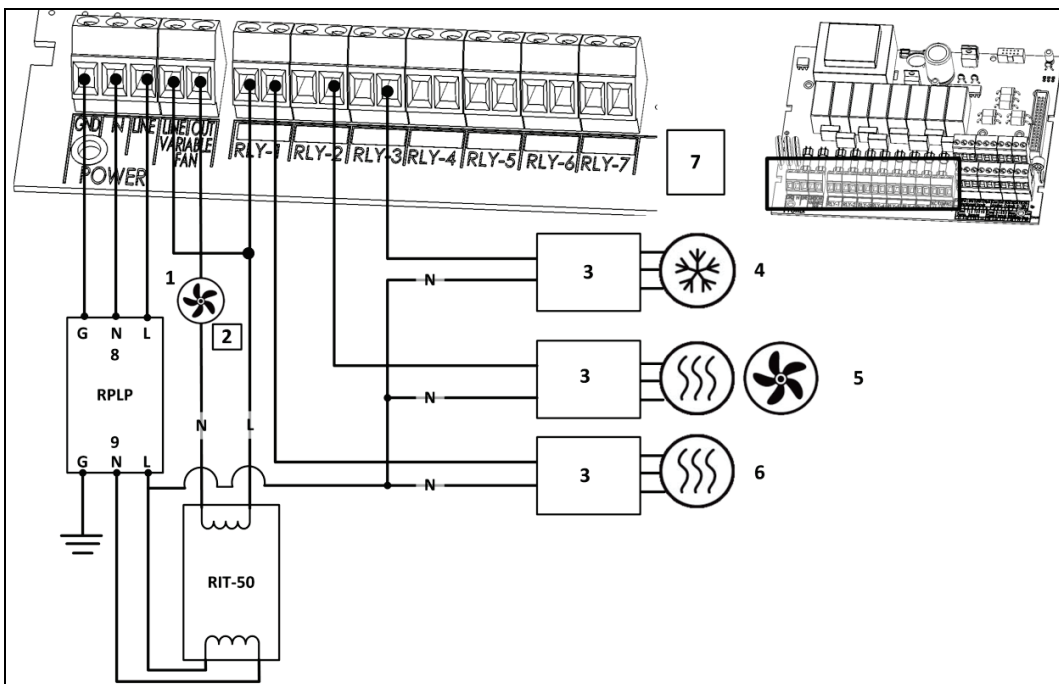

Figure 4: Smart C Wiring Diagram of Main Voltage Section (No Filter) having Protection and Isolation

Figure 4 key			
1	Variable fan	6	Heat 2
2	Only TRIAC versions support direct single phase fan connectivity.	7	The devices shown here are examples only. Actual devices installed differ in actual installments.
3	Three phase contactor	8	Protected output
4	Cooler	9	RIT output
5	Fan 2 or Heater 3		

CAUTION When using a variable fan, verify that the fan is on the same phase as the controller. Working in two different phases causes system failure.

Figure 5 details how to wire an EMC filter to the controller. All the remaining wiring to the main voltage section remains as illustrated in Figure 3 and Figure 4.

CAUTION To ensure compliance with EMC 61000-6-3, install an appropriate filter; for example a TDK-RSHN-2016 L or similar devices.

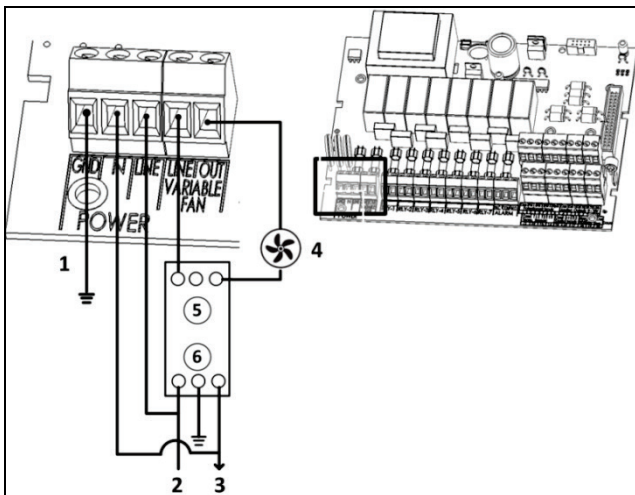

Figure 5: Smart C Wiring Diagram of Main Voltage Section Showing Filtering

Figure 5 key			
1	Grounding wire	3	Neutral
2	Line	4	Variable fan

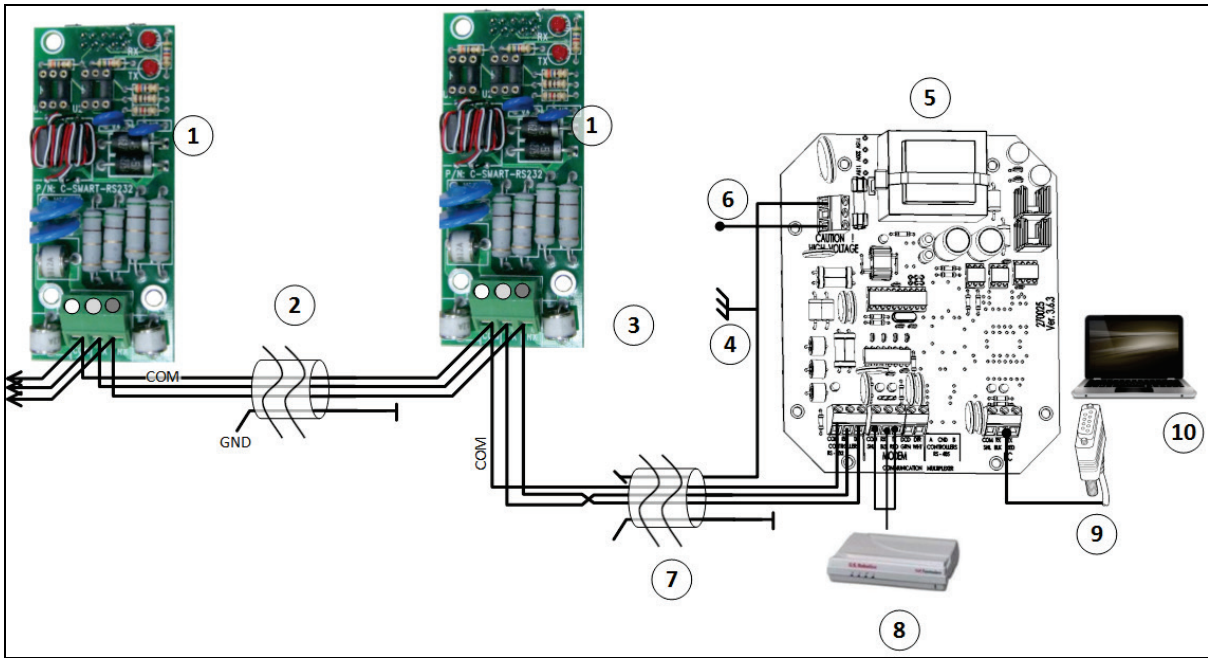

Figure 6: Smart C Communication RS-232 Wiring Diagram

Figure 6 key			
1	Controller communication card	6	Connect shield to ground
2	Long distance wiring	7	See below
3	Connect the cable shields only at 1) one end of every cable in the MUX-232 2) one end of each house	8	Modem (priority channels)
4	Connect shield to ground	9	COM 1, 2
5	MUX RS 232/485 Card	10	Local PC

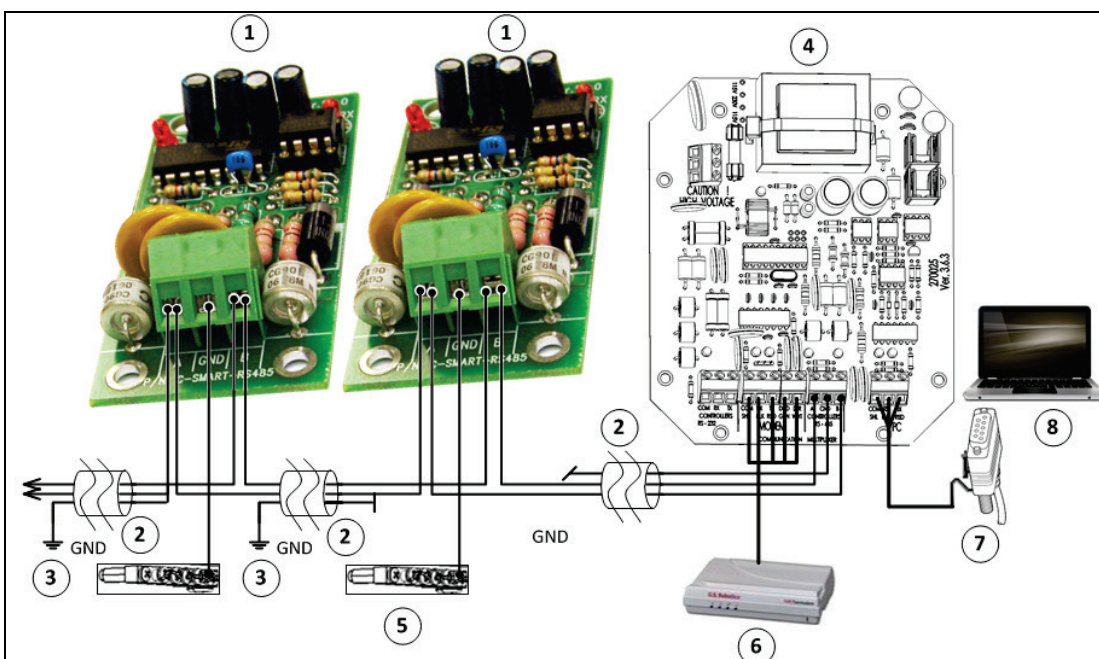

Figure 7: Smart C Communication RS-485 Wiring Diagram

Figure 7 key			
1	Controller communication card	5	See below
2	Long distance wiring	6	Modem (priority channels)
3	The wire shield must be connected at one end only to prevent ground loop	7	COM 1, 2
4	MUX RS 232/485 Card	8	Local PC

- 3-Shielded cable length and baud speed:
 - For one controller:
 - 2000 meters: 9600 Baud
 - 2500 meters: 4800 Baud
 - 3000 meters: 2400 Baud
 - For 10 controllers:
 - 1200 meters: 9600 Baud
 - 1800 meters: 4800 Baud
 - 2400 meters: 2400 Baud

The possible baud rate is dependent on the cable length and the number of controllers connected.

4.3 Smart 10D Wiring

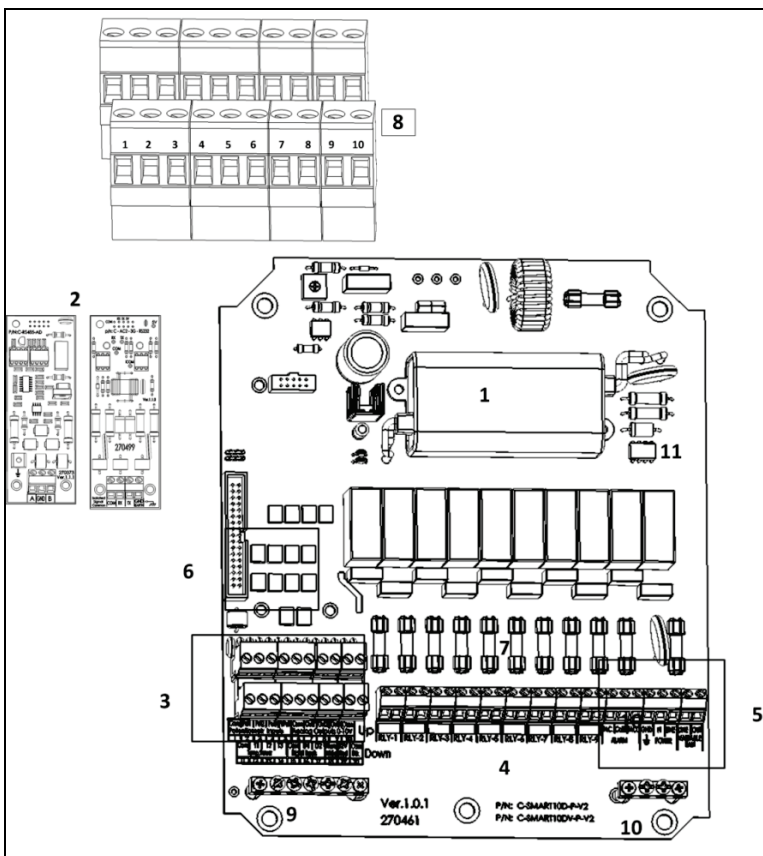

Figure 8: Smart 10DV Board Layout

Figure 8 key			
1	Transformer	7	Fuses
2	Communication card	8	Open the metal plate in a terminal before inserting the cable.

Figure 8 key			
3	Low voltage ports	9	Ground strip
4	Relay ports	10	Ground strip
5	Power ports	11	TRIAC (4CV/8CV only)
6	Input lighting protection		

Communication card part numbers

- C-RNET-232
- C-RNET-485

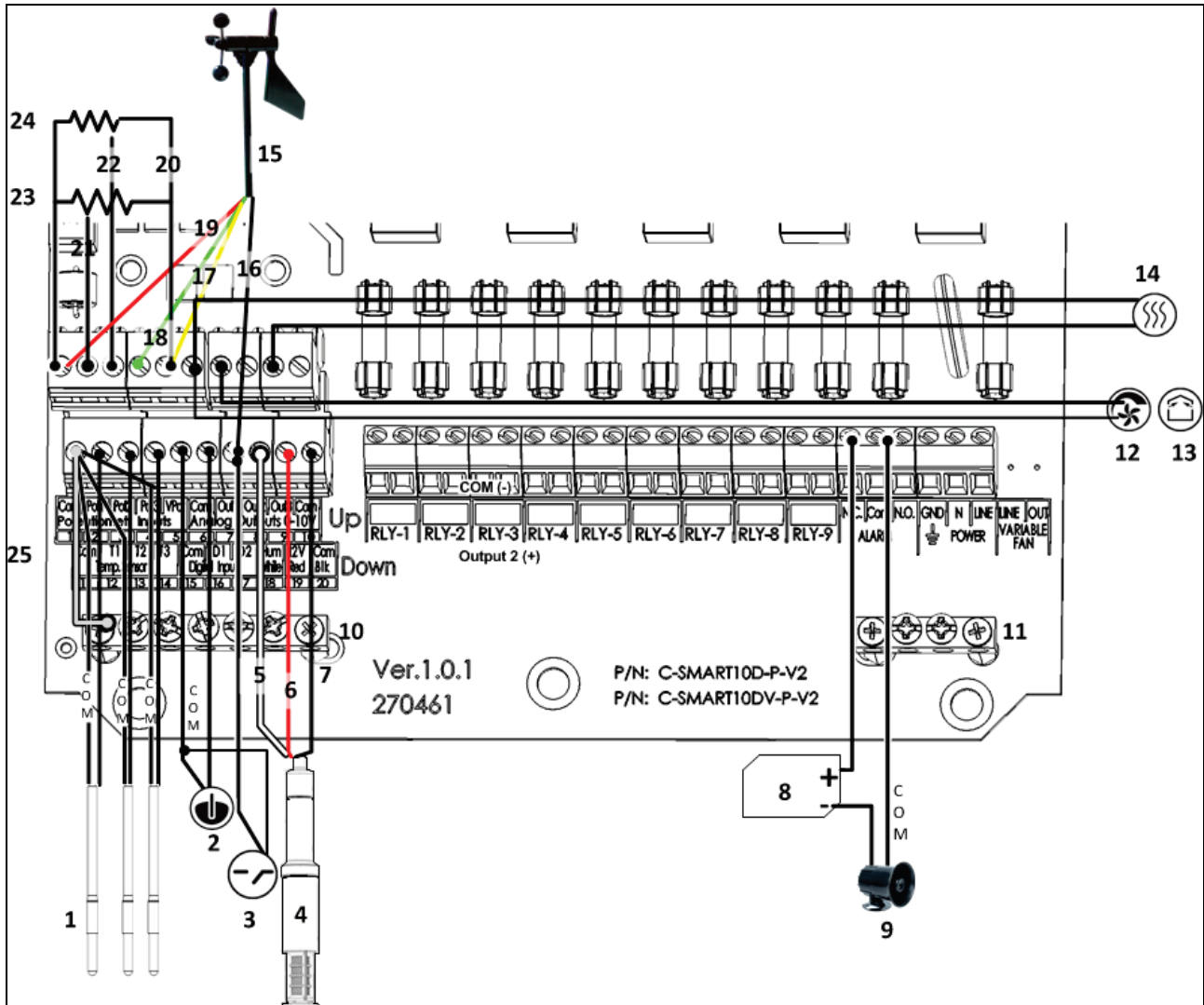

Figure 9: Smart D Wiring Diagram of Low Voltage Section

Figure 9 key		
1: RTS-2 temperature sensors	2: Water meter	3: Feed meter
4: Humidity sensor	5: White wire	6: Red wire
7: Black wire	8: Alarm	9: White wire
10: Ground strip	11: Ground strip	12: Variable fan
13: Inlet	14: Variable heater	15: Wind direction / speed

Figure 9 key		
16: Black wire	17: Yellow wire	18: Green wire
19: Red wire	20: VPot	21: Potentiometer 1
22: Potentiometer 2	23: Curtain 1	24: Curtain 2
25: Shield cable		

NOTE: The alarm relay can be either NC or NO (normally used for an alarm system)

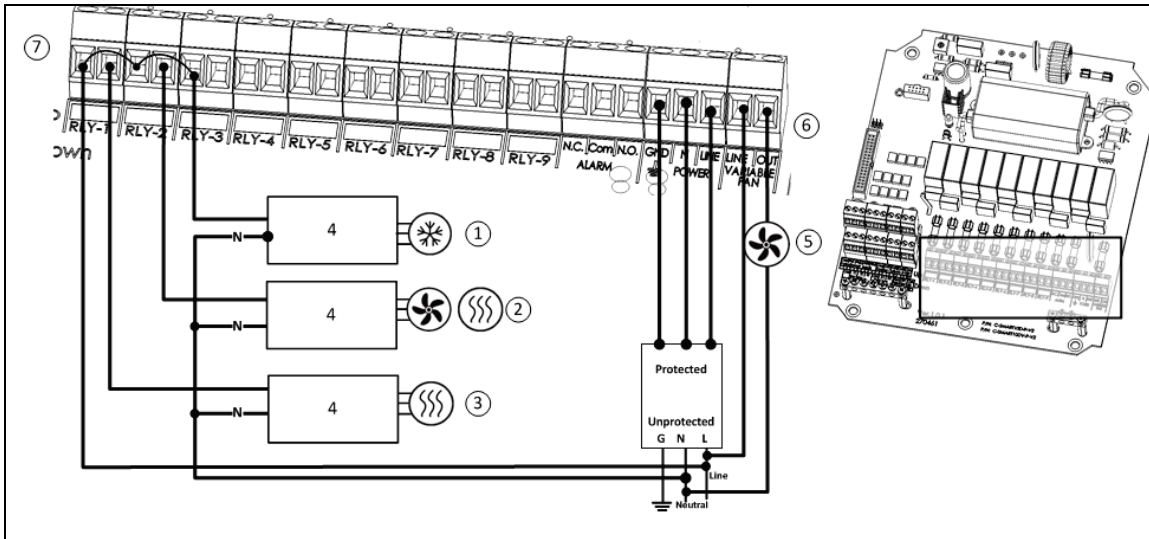

Figure 10: Smart D Wiring Diagram of Main Voltage Section (No Filter) and Protection

CAUTION When using a variable fan, verify that the fan is on the same phase as the controller. Working in two different phases causes system failure.

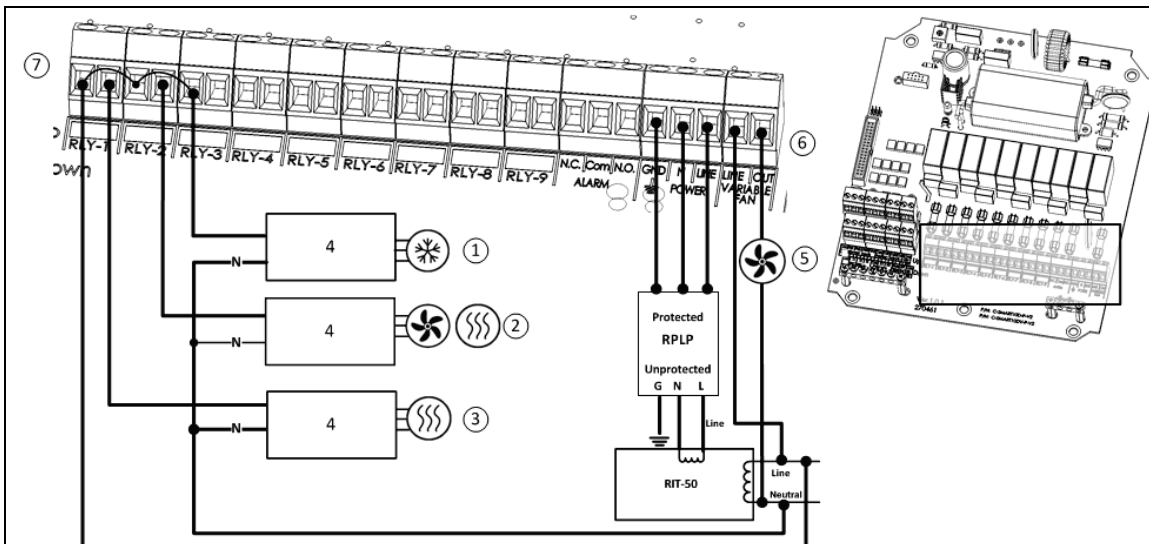

Figure 11: Smart D Wiring Diagram of Main Voltage Section (No Filter) having Protection and Isolation

Figure 10/Figure 11 key			
1	Cooler	5	Variable fan
2	Fan 2 or Heater 3	6	Variable fan

Figure 10/Figure 11 key			
3	Heat 2	7	The devices shown here are examples only. Actual devices installed differ in actual installments.
4	Three phase contactor		

Figure 12 details how to wire an EMC filter to the controller.

CAUTION To ensure compliance with EMC 61000-6-3, install an appropriate filter; for example a Rotem filter (P/N: P-EMI), TDK-RSHN-2016 L or similar devices.

All the remaining wiring to the main voltage section remains as illustrated in Figure 10 and Figure 11.

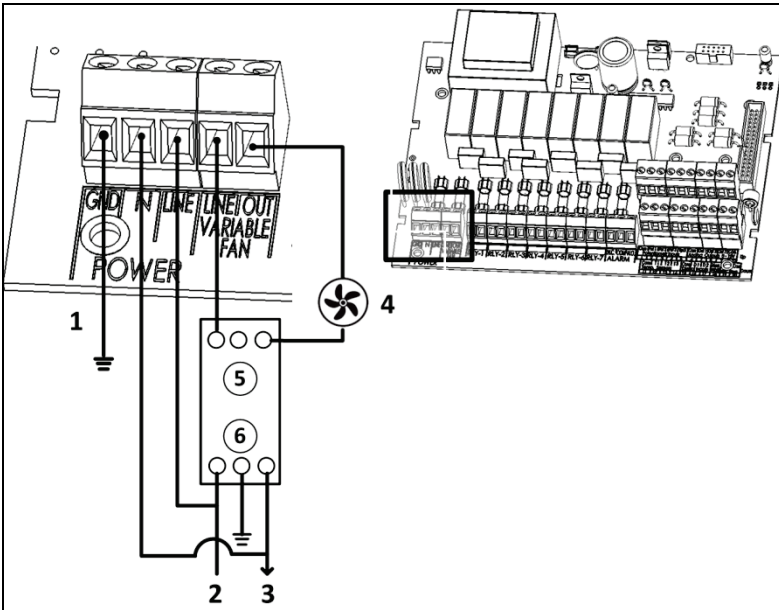

CAUTION Figure 12: Smart D Wiring Diagram of Main Voltage Section Showing Filtering

Figure 12 key			
1	Grounding wire	4	Variable fan
2	Line	5	Output
3	Neutral	6	Input

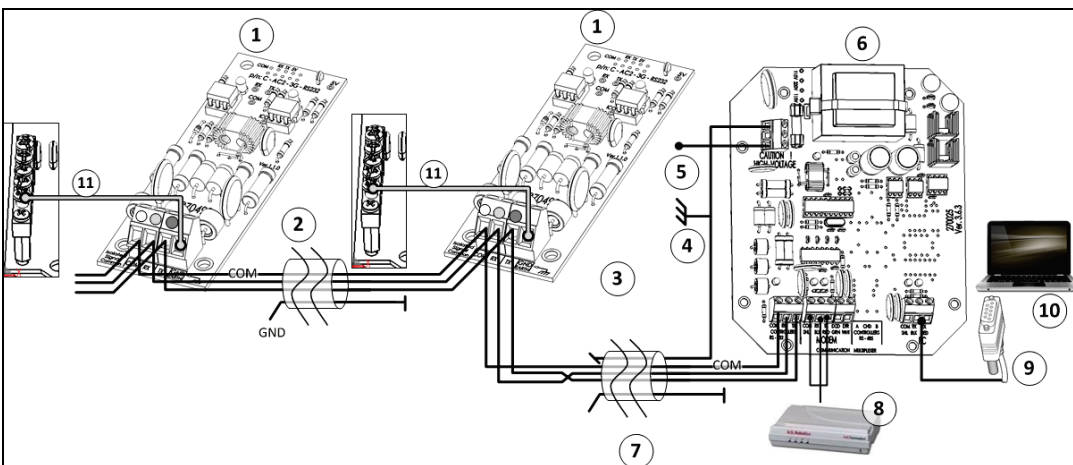

Figure 13: Smart D RS-232 Communication Wiring

Figure 13 key			
1	Controller C-RNET-232 card	6	Connect shield to GND
2	Long distance wiring	7	See below
3	Neutral	8	Modem
4	MUX 232	9	COM 1, 2
5	Neutral	10	Local PC
3-Shielded cable length and baud speed			
For one controller	2000 meters: 9600 Baud 2500 meters: 4800 Baud 3000 meters: 24	For 10 controllers	1200 meters: 9600 Baud 1800 meters: 4800 Baud 2400 meters: 2400 Baud

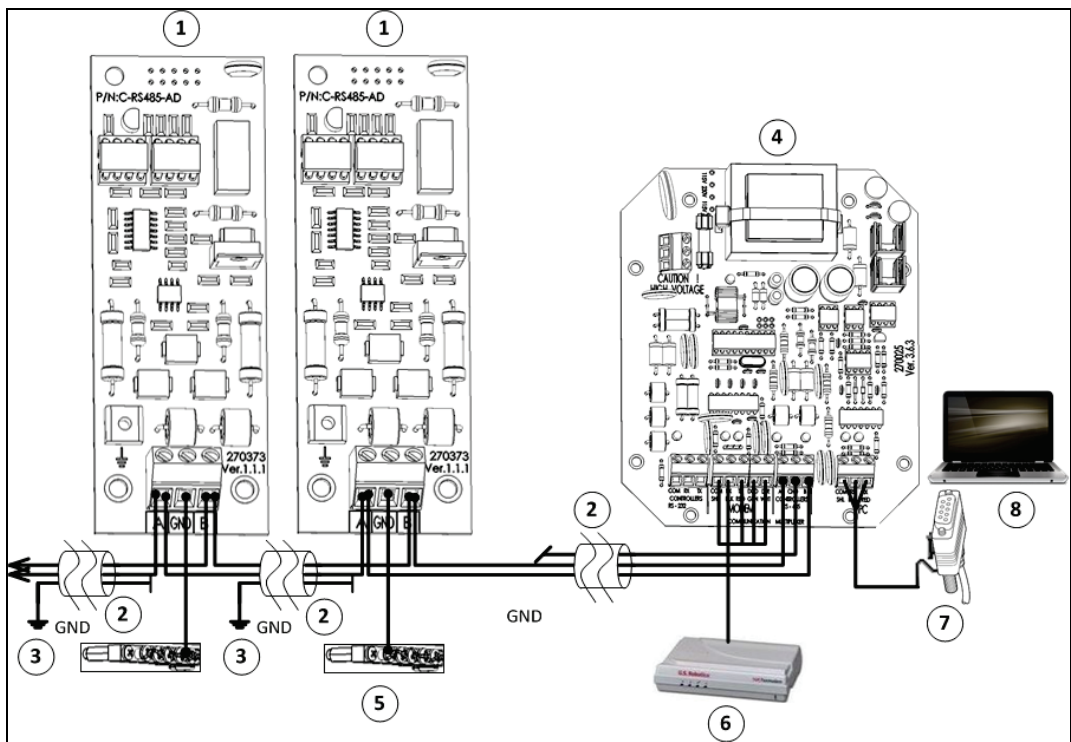

Figure 14: Smart D Communication Card Wiring

Figure 14 key			
1	Controller C-RNET-485 card	5	See below
2	Long distance wiring	6	Modem
3	Leave open; shield on one side only	7	COM 1, 2
4	MUX 485	8	Local PC
3-Shielded cable length and baud speed			
For one controller	2000 meters: 9600 Baud 2500 meters: 4800 Baud 3000 meters: 24	For 10 controllers	1200 meters: 9600 Baud 1800 meters: 4800 Baud 2400 meters: 2400 Baud

5 Using the Smart

The following sections detail how to use the Smart features.

- Temperature menu
- Humidity menu
- Minimum ventilation menu
- Alarms menu
- Growth day menu
- Test menu
- Calibration menu
- System menu
- Additional functions

5.1 Temperature menu

This menu defines the target temperature curve. The screen displays the choice made in the System menu.

- Install temperature sensors as shown in Figure 2 and Figure 9.
- Go to *System > Curve* and select the curve (No Curve, 2 Points, 4 Points).

NOTE: Selecting the curve determines the curve setup for this function and for the minimum ventilation function.

- No Temperature Curve
- Two Point Temperature Curve
- Four Point Temperature Curve
- Automatic temperature adjustment example

5.1.1 No Temperature Curve

When **No Curve** has been chosen, the **TRGT TEMP** is the only parameter that is displayed, and it is changed directly by the user.

5.1.2 Two Point Temperature Curve

Define the temperature point and growth day for both points.

5.1.3 Four Point Temperature Curve

Define the temperature point and growth day for all four points.

NOTE: In any curve, the value of the **Last Day** parameter must be greater than the **First Day** parameter. If the **First Day** parameter has the same value as the **Last Day** parameter, the **Curve** parameter (in **System** menu) does not exist and the controller uses the **Last Temp** parameter as the **Target Temp** menu.

5.1.4 Automatic temperature adjustment example

If the **Growth Day** is less than the **First Day** parameter, **Target Temp** is set to the temperature defined in the **1st Temp** parameter. During the period between the **First Day** parameter and the **Last Day** parameter, the controller automatically adjusts the temperature so that **Target Temp** changes gradually and evenly towards **Target Temp** as defined in the **Last Day** parameter. Once the **Last Day** parameter is reached, **Target Temp** remains permanent at the temperature defined for the **Last Day** parameter.

Consider the following example (Figure 6):

- **1st Temp** is 34.0° C
- **First Day** is 5
- **Last Temp** is 21.0° C
- **Last Day** is 21

As long as **Growth Day** is either less than or equals five, the controller keeps a **Target Temperature** of 34.0° C. After **First Day**, the system adjusts **Target Temperature** that changes. This change is gradual and lasts until **Last Temperature** is reached (on **Last Day**). From **Growth Day** 21 onward, the **Target Temp** is 22.0° C

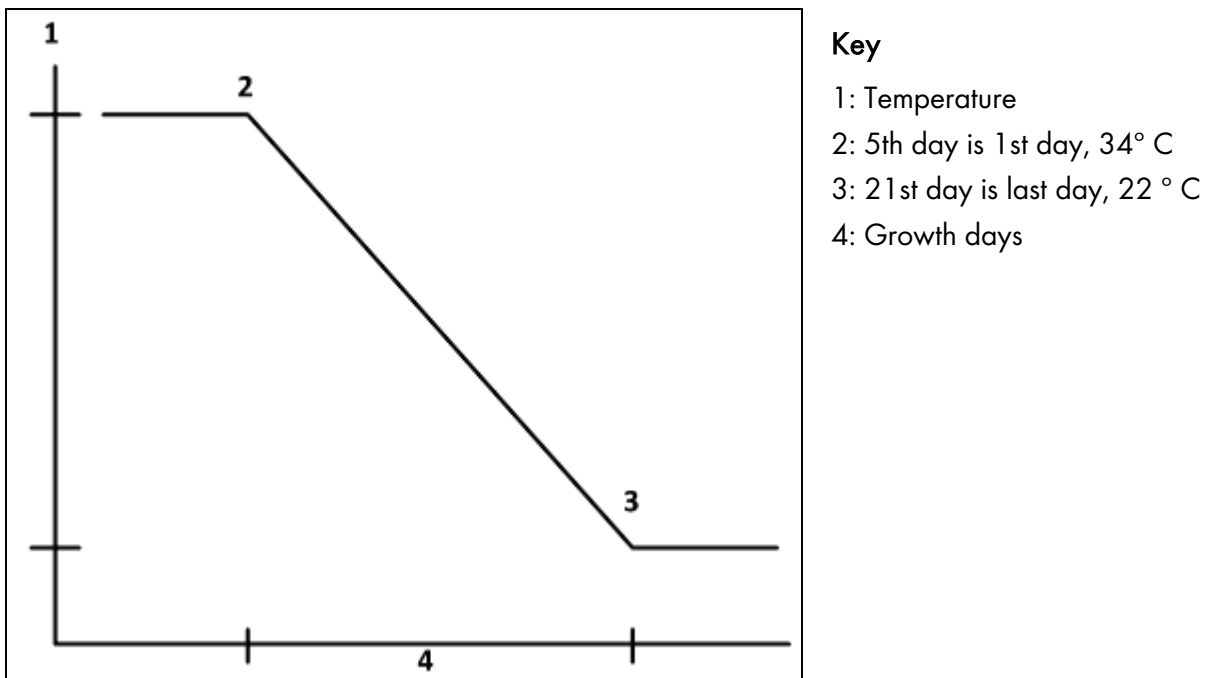

Figure 15: Automatic temperature adjustment example

Table 3 summarizes the temperature adjustment parameters.

Table 3: Target Temperature parameter summary

Parameter Name	Explanation	Minimum Value	Maximum Value	Default Value	Incremental Value
First Temp	First temperature point for creating a curve	0.0°	40.0 °	32.0 °	± 0.1

Parameter Name	Explanation	Minimum Value	Maximum Value	Default Value	Incremental Value
First Day	First growth day to create a curve	1	999	1	± 1
Last Temp	Last temperature point for creating a curve	0.0 °	40.0 °	22.0 °	± 0.1
Last Day	Last growth day to create a curve	1	999	42	± 1

5.2 Humidity menu

This menu defines the target humidity.

🔄 Using this function requires an installed humidity sensor. Refer to Figure 2 and Figure 9.

The parameters are:

- **Target Hum:** Above this value, humidity treatment (see below) begins.
- **Hum Dur (s):** The number of seconds humidity treatment lasts
- **Hum Delay (m):** The number of minutes the controller "waits" before humidity treatment begins.

If no humidity sensor is installed, this menu is not displayed. Table 4 summarizes the target humidity parameters.

Table 4: Target Humidity parameter summary

Parameter Name	Explanation	Minimum Value	Maximum Value	Default Value	Incremental Value
Target Hum:	Target humidity	0%	100%	65%	± 1
Hum Dur. (s):	Humidity treatment duration (seconds)	0	999	60	± 1
Hum Delay (m):	Number of minutes before humidity treatment starts	0	99	3	± 1

5.2.1 Humidity treatment

Humidity treatment is the addition of ventilation for the specified duration time. For instance, in the table above, if the humidity remains above the target humidity (65%) after the delay time has passed, humidity treatment begins and continues until the humidity drops below 63% [target - %2].

5.2.2 How is humidity treatment performed?

Ventilation is added to the current ventilation in one of the following ways:

- **In minimum ventilation:**
 - If a cycle is set, CYCLE ON time is increased by the duration value, and OFF time is decreased by the duration value (if OFF time is less than 5 seconds, operation is continuous).

- If no cycle is set, a cycle is activated between duration (ON time) and delay (OFF time).
 - **Above minimum ventilation:**
 - If the temperature is within the variable fan band width, fan percentage increases to maximum for the duration time.
 - Above variable fan band width, humidity treatment activates the fan with the next closest ON time.
- See the explanation regarding cycles in the next section.

5.3 Minimum ventilation menu

This cycle defines the Minimum Ventilation Fans ON / OFF times.

➡ Go to *System > Curve* and select the curve (No Curve, 2 Points, 4 Points).

NOTE: Selecting the curve determines the curve setup for this function and for the temperature curve function.

- No ventilation curve
- Two point ventilation curve
- Four point ventilation curve

5.3.1 No ventilation curve

Fixed ON and OFF times are set.

- **Cycle on:** Number of seconds in minimum ventilation to operate the fan(s).
- **Cycle off:** Number of seconds in minimum ventilation in which the fans do not operate.

5.3.2 Two point ventilation curve

➡ Define the first and last days in the Temperature Menu.

The controller builds the curve of the ON / OFF times according to the first and last day, which are set in the **Target Temp** menu. The following parameters define the beginning and ending reference points (in seconds) for the curve to follow.

- **First day on:** Define the minimum ventilation fans ON time (in seconds)
- **First day off:** Define the minimum ventilation fans OFF time (in seconds)
- **Last day on:** Define the minimum ventilation fans ON time (in seconds)
- **Last day off:** Define the minimum ventilation fans OFF time (in seconds)

5.3.3 Four point ventilation curve

The controller builds the curve of the ON / OFF times according to the first and last day, which are set in the **Target Temp** menu. The following parameters define the reference points (in seconds) for the curve to follow.

- **First day on:** Define the ON time (in seconds) for the minimum ventilation fans
- **First day off:** Define the OFF time (in seconds) for the minimum ventilation fans
- **Second day on:** Define the minimum ventilation fans ON time (in seconds)
- **Second day off:** Define the minimum ventilation fans OFF time (in seconds)
- **Third day on:** Define the minimum ventilation fans ON time (in seconds)

- **Third day off:** Define the minimum ventilation fans OFF time (in seconds)
- **Last day on:** Define the minimum ventilation fans ON time (in seconds)
- **Last day off:** Define the minimum ventilation fans OFF time (in seconds)

The following is an example of a two point curve:

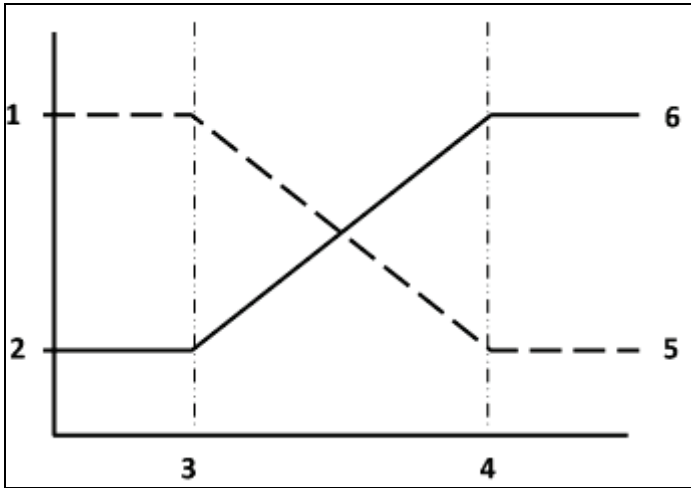

Key

- 1: First day off (270 seconds)
- 2: First day on (30 seconds)
- 3: First day (5)
- 4: Last day (42)
- 5: Last day off (30 seconds)
- 6: Last day on (270 seconds)

5.4 Alarms menu

This menu enables to set the alarms.

- **Hi T. (Diff):** The differential above the target temperature for alarm.
- **Lo T. (Diff):** The differential below the target temperature for alarm.
- **Delay (sec):** The number of seconds before the alarm is being activated.

Table 5 summarizes the alarm parameters.

Table 5: Alarm parameter summary

Parameter Name	Explanation	Default Value	Increment Value	Minimum Value	Maximum Value
Hi T. (Diff):	High temp differential from target	7.0°	± 0.1	1.0 °	99.0°
Lo T. (Diff):	Low temp differential from target	-5.0°	± 0.1	-99.0 °	-1.0°
Delay (sec):	Alarm delay	60	± 1	10	999

5.5 Growth day menu

This menu enables to set the growth day.

- **Growth Day:** Set the growth day. If this parameter is set to '0', **New Group** option appears. This option verifies that this is the user's final selection, since it deletes all the history information. Otherwise, the user returns to **Growth Day** menu.

Table 6 summarizes the alarm parameters.

Table 6: Growth Day parameter summary

Parameter Name	Default Value	Incremental Value	Minimum Value	Maximum Value
Growth Day	1	±1	0	999

5.6 Test menu

This menu allows testing of both the sensors and the relays. Moreover, it displays both the software and the communication versions.

Pressing <P.> when any of the relay items (FAN1, FAN2 or Cooling) is shown causes the controller to pause. Pressing <OK> once again makes the controller resume operation.

The parameters are explained below;

- **Var Fan:** Tests variable fan
- **T1/T2/T3:** Tests temperature sensor number 1 - 3
- **RELAY #:** Tests if relays are on or off
- **Pot-2:** View potentiometer A/D (curtain)
- **Digital Input-1/2:** Tests the digital input pulses (water pulses, wind speed)
- **Hardware Ver:** Check the hardware version
- **Comm Ver:** Check the communication version
- **Read Data?** : Upload previously saved settings from data plug to the controller
- **Comm Test:** Check the communication link between the controller and PC.
- **Analog Output 1/2:** Tests ANALOG OUTPUT 1 and 2
- **Humidity:** Tests humidity sensor
- **Pot -1:** View potentiometer A/D (curtain)
- **Pot-3:** View potentiometer A/D (wind direction)
- **Sft VER:** Check the software version
- **Sys Reset:** System Reset (for technician's use only!)
- **Hardware Ver:** Check the hardware version
- **Save Data?** : Save current settings to data plug (overwrites data plug)

NOTE: Only SMART 8C/8CV/10D support testing potentiometers.

5.7 Calibration menu

This menu allows sensor calibration. The user can change either the temperature or the humidity sensor output value and the system remembers the difference between the system's calculation and the changed calibration value. As a result, the difference between the system calculation and the changed calibration are included in the system.

NOTE: If an error occurs either with a temperature sensor or with a humidity sensor, the information regarding the specific sensor can be deleted from the **Calibration** menu. This is done by pressing <P> when an invalid sensor's field appears.

- **T1:** Temperature sensor number 1.
- **T2:** Temperature sensor number 2.
- **T3:** Temperature sensor number 3.
- **Hum:** Humidity sensor. This sensor can be calibrated up to ± 25% from the calculated value.

- **Wind Direction**
- **Water / Pulse:** Number of pulses that define a unit. The measured unit is not important since it suits all units.
- **Feed / Pulse:** Number of pulses that define a unit. The measured unit is not important since it suits all units.
- Curtain calibration (1 & 2)

NOTE: Only the SMART 8C/8CV/10D/10DV support curtain calibration.

5.7.1 Calibration of curtains using potentiometers

Calibration is performed in the following way: the curtain closes; after the value does not change for 15 seconds, it is set as the closed curtain value. Then, the curtain opens, and the value changes. When the value does not change for 15 seconds, that value is set as the open curtain value. Afterwards the curtain closes again, and closing duration is measured, as well as the opening duration.

To stop the calibration process, press **OK**.

5.7.2 Calibration of curtains without potentiometers

1. Set up the system with no potentiometers: Go to SYSTEM, > Pot and select: 0.
2. Set up the close/open times for the curtains. It is very important to measure the time precisely.
3. Set up the number of steps for automatic calibration: Go to SYSTEM > Cal. Steps.

Example: If the number of steps is 50, then the controller opens the curtain every 50 movements of the curtain for the entire opening time and then returns the curtain to its previous position.

4. **Wind direction:** Enter the required wind direction value.

5.8 System menu

This menu sets the system parameters.

- **Curve:** Select whether to create one of the following curves from the temperature data:
 - No Curve: Does not create a curve
 - 2 Points: Creates a 2 point curve
 - 4 Points: Creates a 4 point curve

NOTE: Activation of this parameter enables a curve in the Temperature menu **and** Minimum ventilation menu.

- **Variable Fan By:** Select one of the following curves (refer to Variable fan, page 33):
 - Speed
 - Cycle
 - **Temp-3:** Define sensor 3 as **In** and **Out**.
- **Natural Vent:** Disable / enable natural ventilation (refer to Natural ventilation, page 38)

NOTE: When in Natural Mode, the ventilation mode Hot Key displays NAT.

- **Tunnel Fan:** displays a list of all available fans. If a fan is selected then once that fan begins to operate, the controller functions under TUNNEL MODE. Curtain 1 and Air Inlet closes completely and Curtain 2 becomes the TUNNEL curtain. If NONE is selected, TUNNEL MODE is disabled.

NOTE: When TUNNEL MODE is active, the ventilation mode Hot Key displays TUN.

- **Relays and Analog Output:** Refer to Smart layouts, page 8.
- **Digital Input 1:** Water Meter
- **Digital Input 2:** Select between Feed and Wind Speed
- **Pot (0/1/2/1+2):** Choose the number of the active curtain potentiometers (can be either 0 curtains, curtain, curtain, or curtain + curtain, which is set as "3").
- **Calibration steps:** Choose the number of curtain movements before automatic calibration is performed. To disable this function enter 99).

NOTE: Only SMART 8C/CV and 10D/10DV support potentiometers and calibration steps.

- **History:** Can be one of the following values: 1 Hr, 2 Hrs, 3 Hrs, 4 Hrs, 6 Hrs, 8 Hrs, 12 Hrs, and 1 Day.

The **History** parameter consists of the following recorded fields:

- | | |
|---------------------------|--------------------------------|
| • Growth Day | • Time |
| • Target Temperature | • Average T1 Temperature |
| • Average T2 Temperature | • Averaged T1 Temperature |
| • Averaged T2 Temperature | • Averaged Outside Temperature |
| • Averaged Humidity | |

NOTE: Viewing the history data can requires a PC having communication with a controller.

- **Time:** Set the system time.
- **Unit No:** Define the unit number for communication purposes.
- **Baud Rate:** Choose the requested value from the following: 2400, 4800, 9600, 19200. This parameter is a measure of data transmission speed for communication purposes.
- **Curtain 1/2/open/close:** opening and closing times of curtains automatically change after curtain calibration.
- **Empty House Mode:** When the house is empty, it is recommended to disable all the alarms, set this parameter to YES in order to do so. On the main screen the message "EMPTY HOUSE" are displayed.
- **Temperature Unit:** Choose Celsius or Fahrenheit

5.9 Additional functions

- Light function
- General timer

5.9.1 Light function

The Light Function enables setting up a time table for the house lighting.

To set up the light function:

1. Go to *System > Relay 9*.
2. Set the relay to **Light**.
3. Go to *Settings > Light*.
4. Set From <Time> and To <Time> points. Up to 10 lines (five periods) can be set.

NOTE: Only the SMART 8C/8CV/10D/10DV support this feature.

5.9.2 General timer

The general timers can be assigned to any operation wished. The timers allow control over desired operation's operating cycle.

1. Go to *System > Relay 2*.
2. Set the relay as timer.
3. Go to *Settings > Timer*.
4. Set the following parameters:
 - **From time:** Start Time frame.
 - **To time:** End Time frame.
 - **ON time:** ON cycle time in seconds.
 - **OFF time:** OFF cycle time in seconds.

NOTE: Only the SMART 8C/8CV/10D/10DV support this feature.

6 Cooling and heating functions

This section details how to set Smart's cooling and heating functions.

- Cooling Functions
- Heating functions

6.1 Cooling Functions

➡ Wire the fans as required, as shown in Figure 3 - Figure 5 and Figure 10 - Figure 12.

Smart supports the following ventilation methods:

- Variable fan
- Minimum ventilation cycle fan
- On/Off fan
- Natural ventilation
- Curtain
- Air inlet
- Cool parameters

6.1.1 Variable fan

1. Go to *System > Analog Output 1*.
2. Set the output as Variable Fan.
3. Go *System > Variable Fan by*.
4. Select one of the following:
 - Using a Variable Fan without a Curve
 - Using a Variable Fan with a Curve
5. Go to *Settings > Variable Fans*.

NOTE: In SMART 4CV/8CV/10DV: If you define analog output 1 as a variable fan, define the following parameters for the TRIAC and analog output fans separately (*Settings > Var Fan #1 / Settings > Var Fan #2*).

NOTE: SMART 8C, Version 2.06, supports setting two analog outputs as variable fans. To set a second analog output as a variable fan, go to *System > Analog Output 2*. Both variable fans have the same curve setting.

6.1.1.1 Using a Variable Fan without a Curve

Figure 15 illustrates a fan operational scheme.

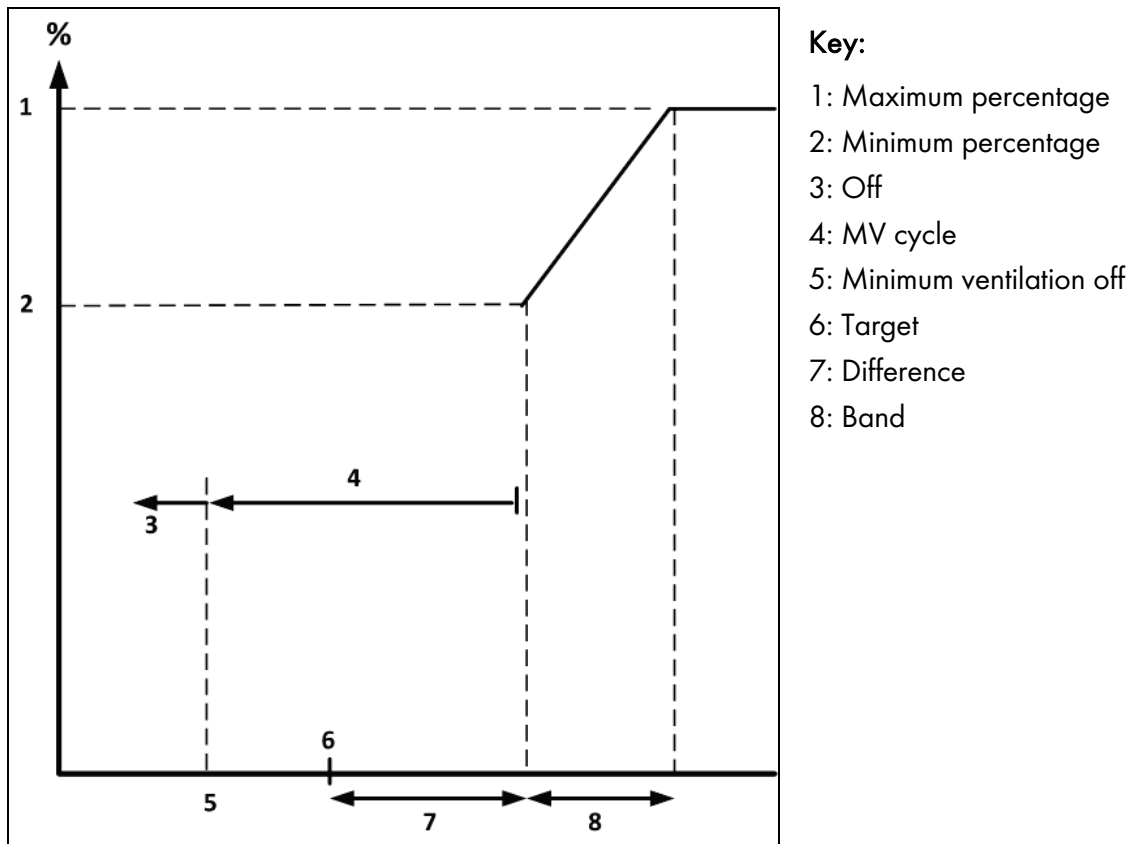

Figure 16: Variable Fan, No Curve

- Below the MV Off temperature, fans cease to operate.
- In the area labeled MV Cycle, minimum ventilation cycle (page 27) defines the on/off times.
- In the area labeled band, fans run at a curve determined by the below parameters.
- The Hot Keys displaying the minimum and maximum variable speeds (F1/F2) show the same number throughout the growth cycle.

Define the following parameters:

- **Diff:** Fan ON temperature differential above which the fan starts operating.
- **Band:** Fan temperature band: starts at ON temperature; in this range the fan increases from the minimum to maximum operating percentage.
- **MV Off:** The differential below target at which to stop the cycle of the Fan for minimum ventilation.
- **Min Spd:** Fan percentage of minimum operation rate.
- **Max Spd:** Fan percentage of maximum operation rate.
- **MV Day:** The minimum ventilation proceeds from this day forward regardless of the temperature and MV OFF parameter.

NOTE: If V.Fan is an analog output (not built-in TRIAC fan), two additional parameters appear:

- **Min/Max Vlt:** Define the possible minimum/maximum voltage for fan operation

6.1.1.2 Using a Variable Fan with a Curve

Variable Fan by Speed enables building a ventilation curve featuring stages. The stages are the days set in the Minimum ventilation menu (page 27). Figure 16 illustrates an example curve. The variable fan uses the same cycle times set in Temperature menu, page 24 and Minimum ventilation cycle fan, page 35.

- As the target temperature decreases (see Figure 3), the minimum and maximum speeds adjust themselves.
- The Hot Keys displaying the minimum and maximum variable speeds (F1/F2) show different numbers, depending on the controller's calculations.

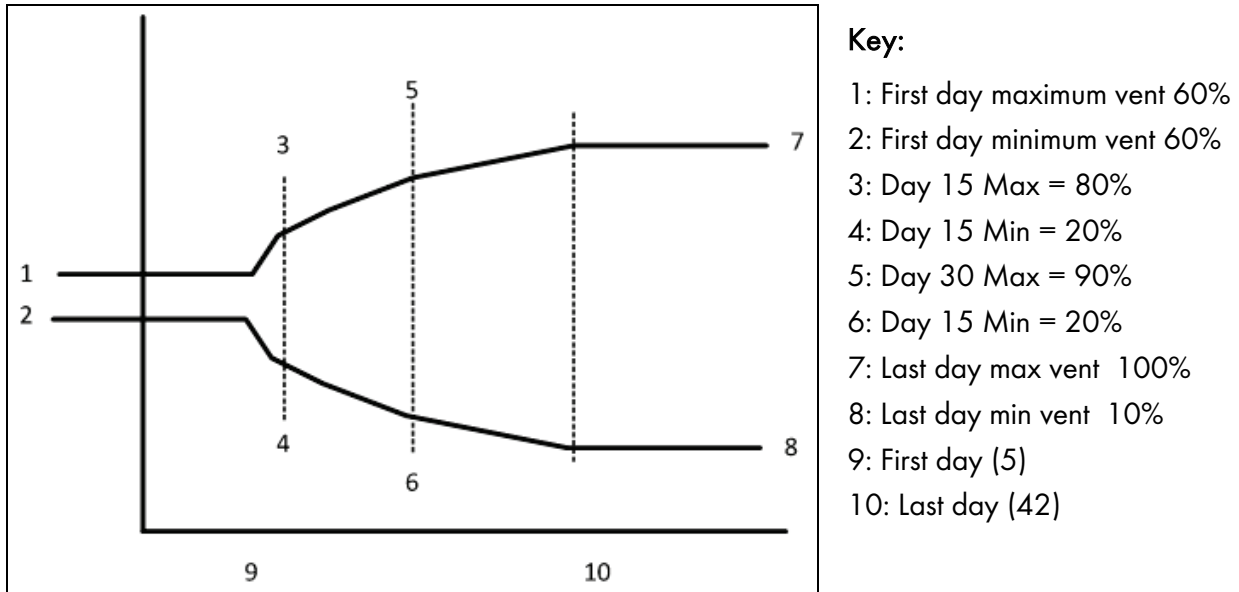

Figure 17: Variable Fan, Minimum - Maximum Cycle Timer

This option includes the above parameters, as well as:

- 1st minimum/maximum speed: Set the fan minimum and maximum speeds for the 1st day.
- 2nd minimum/maximum speed: Set the fan minimum and maximum speeds for the 2nd day.
- 3rd minimum/maximum speed: Set the fan minimum and maximum speeds for the 3rd day.
- Last minimum/maximum speed: Set the fan minimum and maximum speeds for the last day.

6.1.2 Minimum ventilation cycle fan

1. Go to *System > Relay 1*.
2. Set the output as Fan 1.
3. Go to *Settings > Fan 1 (Min)*.
4. If required, repeat for Relay 2 and MV Fan 2.
5. Define the following parameters.

The following section details the Minimum Ventilation Cycle Fan parameters:

- **F. T. ON:** The temperature differential above target temperature to turn on the fan.
- **F. T. OFF:** The temperature differential above target temperature to turn off the fan.
- **F. MV. OFF:** The differential below target at which the fan is off in minimum ventilation.
- **F# MV Day:** The minimum ventilation proceeds from this day forward regardless of the temperature and *MV OFF* parameter.

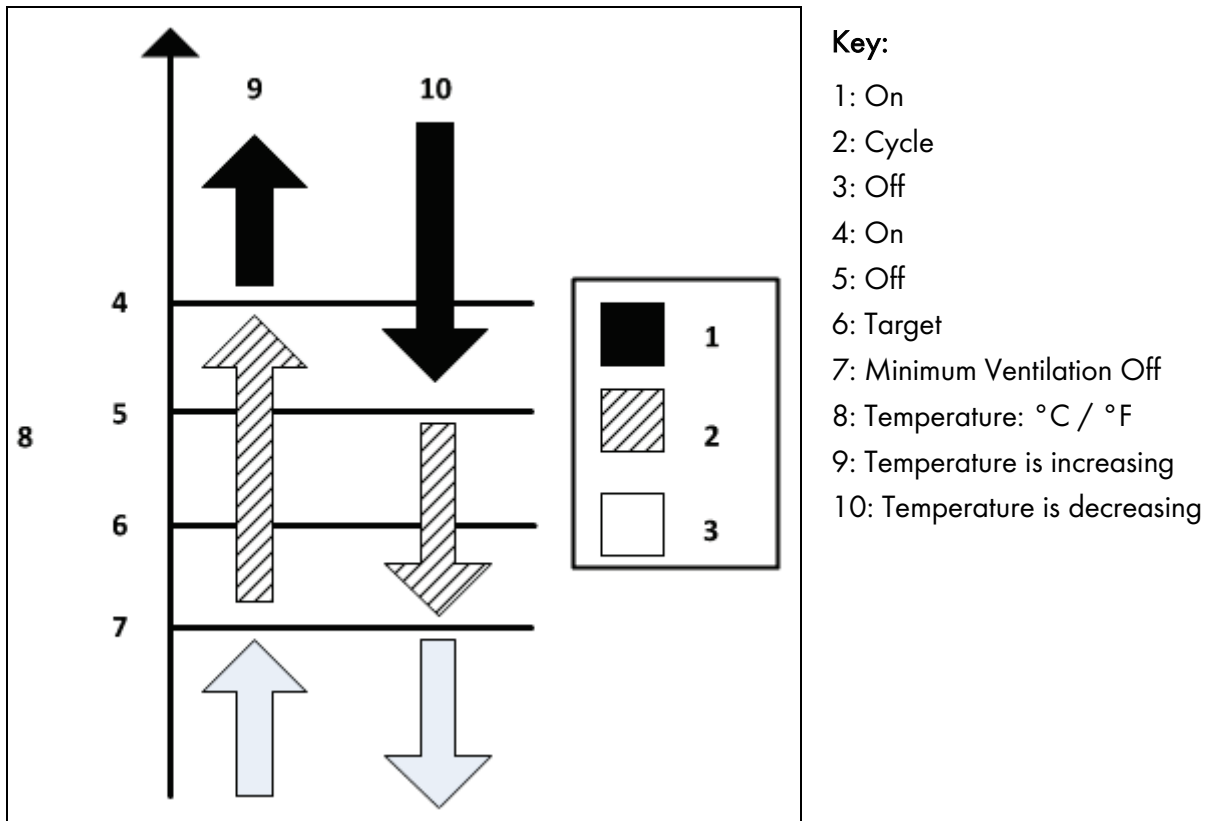
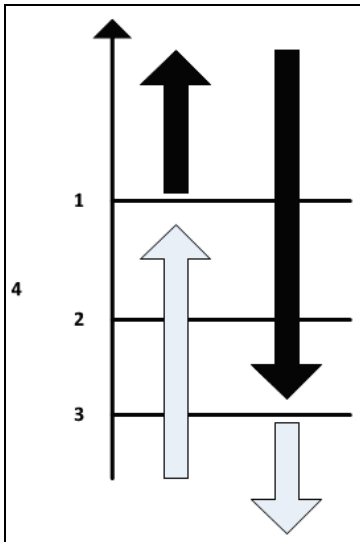

Figure 18: Minimum ventilation fan scheme

6.1.3 On/Off fan

The following section details the On/Off fan parameters.

1. Go to *System > Relay 3*.
2. Set the output as **Fan On/OFF 5**.
3. Go to *Settings > Fan 5*.
4. Repeat as required.
5. Define the following parameters.
 - **F. T. ON:** The temperature differential above target temperature to turn on the fan.
 - **F. T. OFF:** The temperature differential above target temperature to turn off the fan.



Key:

- 1: On
- 2: Target
- 3: Off
- 4 Temperature: °C / °F

Figure 19: ON/OFF Fan Scheme

6.1.4 Natural ventilation

NOTE: SMART 8C/8CV and SMART 10D/DV support natural ventilation.

NOTE: : If you are NOT using Natural Ventilation, go to the **SYSTEM** menu and set the *Natural Ventilation* parameter to NO. This hides the **NATURAL ENTRY**.

1. Go to *System > Natural Ventilation*.
2. Select Yes.
3. Go to *Settings > Natural Entry*.
4. Define the following parameters.

NOTE: Natural Ventilation is in effect only when all of the following conditions are met:

- **From/To day:** Day range that enables natural mode entry.
- **From/To time:** Time frame during the day to enables natural mode entry.
- **Low/High Inside temp diff:** Temperature differential range to enter natural mode below/above target temperature.
- **Low/High Outside temp diff:** Temperature differential range to enter natural mode below/above target temperature.
- **Temp band:** This parameter relates to the previous four parameters, which determines the Natural Mode band. To avoid chatter between Power and Natural mode, we add/subtract this value from the previous four parameters to create two different bands, one to enter and one to exit natural mode.

The following is an example for Temp Band:

- Target temperature: 25° C
- Low temperature diff: -3.0° C
- High temperature diff: 3.0° C
- Temp band: 1.0

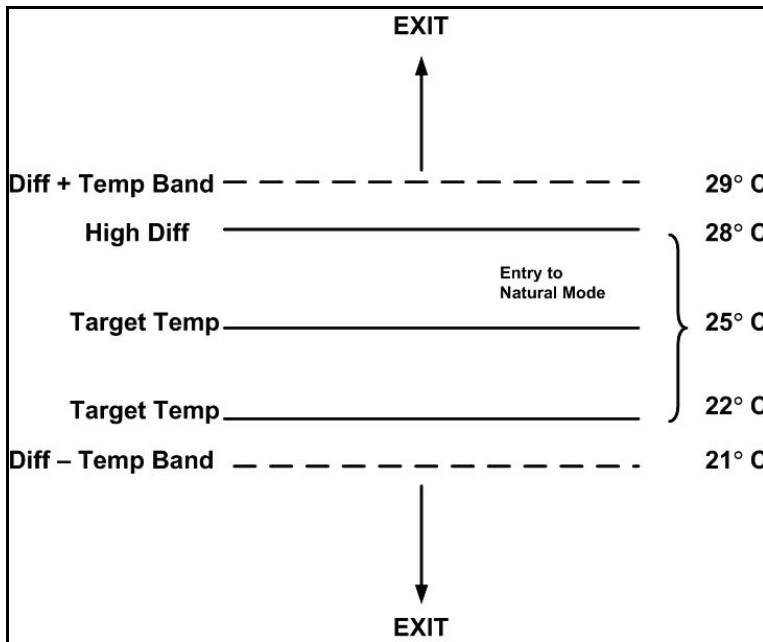

Figure 20: Temperature band scheme

- **Max wind speed entry:** Maximum wind speed allowed for entering the natural mode.
- **Exit wind speed:** Maximum wind speed allowed in the natural mode, beyond which the controller exits natural mode.

6.1.5 Curtain

NOTE: SMART 8C/8CV and SMART 10D support curtain control.

1. Go to *System > Relay 4*.
2. Select **Curtain 1 open**.
3. Go to *Relay 5*
4. Select **Curtain 1 close**.
5. Go to *Relay 6 and 7* and repeat (if required).
6. Go to *Settings > Natural Entry*.

The controller is either programmed for [natural ventilation](#) or [power ventilation](#) (side wall or tunnel fans). Natural ventilation is in effect only when all conditions predefined are met.

6.1.5.1 Natural ventilation

When the controller is in **natural ventilation**, the following parameters control the curtain behavior:

- **Curtain diff to open:** Differential above target temperature to open curtain.
- **Curtain diff to close:** Differential above target temperature to close curtain.
- **Stage delay (sec):** Set delay time before opening or closing, once the happy zone has been exceeded. (Happy Zone: the zone where conditions for natural mode are met).
- **Curtain Min Open:** Curtain does not close more than the Minimum opening
- **Curtain Max open:** Curtain does not open more than the Maximum opening.
- **Step size (%):** Set increment in percentage between each level.

If required, define the:

- Wind speed and direction sensors

- Curtains and Variable Fans

6.1.5.2 Wind speed and direction sensors

If **wind speed** and **direction sensors** are installed, the following parameters are also relevant:

- **Wind direction from:** the angle FROM which wind direction affects each curtain.
- **Wind direction to:** the angle UNTIL which wind direction affects each curtain.
- **Wind speed:** speed to which the following two parameters relate:
 - **Curtain Max open in speed and direction:** maximum curtain opening in strong winds in the direction of curtain.
 - **Curtain Max open in speed and not in direction:** maximum curtain opening in strong winds but not in the curtain's direction.

NOTE: (1) The parameters above do not appear if natural ventilation is disabled. (2) If two curtains exist, parameters above are defined for each curtain separately.

6.1.5.3 Curtains and variable fans

If a variable fan is being used, define the following parameters:

- **Minimum Position:** Minimum curtain opening position at any temperature
- **Variable Fan From:** When the temperatures reaches [variable fan temperature plus the diff], curtains open to this position.
- **Variable Fan To:** When the temperatures reaches [variable fan temperature plus diff plus band], curtains open to this position.
- **Minimum ventilation fan:** Curtain position when minimum ventilation is operating.

6.1.5.4 Power ventilation

☞ **In System, define curtain opening and closing times.**

When the controller is in **power ventilation**, the following parameters appear:

- **Minimum Curtain Position:** define the curtain minimum opening position.

NOTE: : The following parameters appear only if the fan is installed and defined. The percentages from **Min.Pos** until **the last fan** (if defined) are summed together to form the total minimum opening during fan operation.

- Define the additional opening for each fan (A curve is created for curtain opening according to the Variable Speed Fan's intensity).

6.1.6 Air inlet

1. Go to *System > Analog Output 1*.
2. Select **Inlet**.
3. Go to *Settings > Air Inlet*.
4. Define the following parameters.
 - **F1 Min Open:** Minimum opening of air inlet (in example 30%)
 - **F1 Max Open:** Maximum opening of air inlet (in example 80%)

Level of opening follows the behavior of variable fan (**Figure 15**).

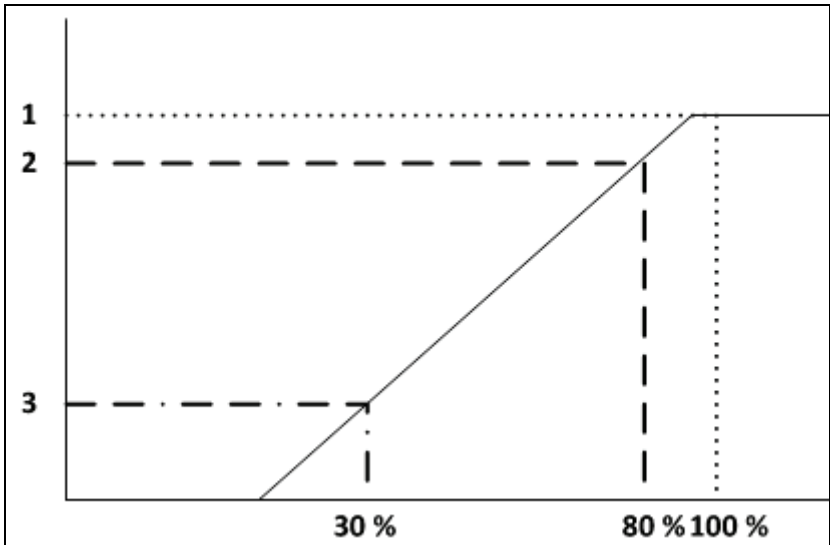

Key:
 1: Fan 2 is on
 2: Maximum percentage
 3: Minimum percentage

Figure 21: Air Inlet Scheme

- **Pos. On Fan 2:** Define a fixed position for air inlet to open, in case that Fan 2 is ON (in example 100%).

6.1.7 Cool parameters

1. Go to *System > Relay 3*.
2. Select *Cooling*.
3. Go to *Settings > Cooling*.
4. Define the following parameters.
 - **Cool T. On:** The differential above target temperature the cooling system is on.
 - **Cool T. Off:** The differential above target temperature the cooling system is off.
 - **Cool To Hum:** The limit of relative humidity above which the cooling system does not operate, even if the condition for **Cool T. On** is met.
 - **Cool On (s):** The number of seconds to turn on the Cooling System.
 - **Cool Off (s):** The number of seconds to turn off the Cooling System.

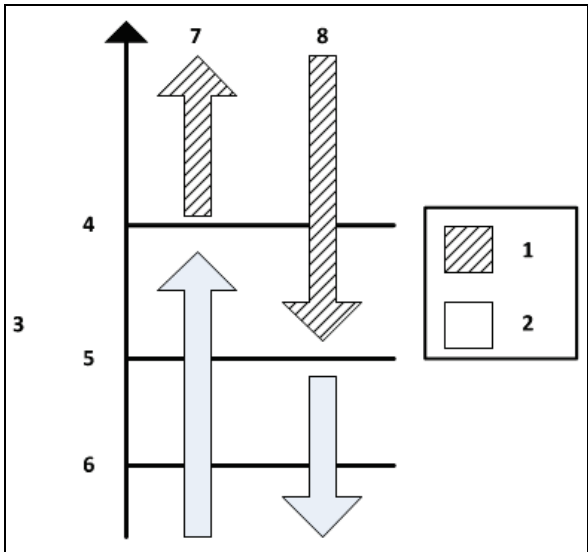

Key
 1: Cycle
 2: Off
 3: Temperature °C / °F
 4: On
 5: Off
 6: Target
 7: Temperature is increasing
 8: Temperature is decreasing

Figure 22: Cooling Scheme

NOTE: If humidity % is above the **COOL TO HUM**, then Cooling is turned off.

6.2 Heating functions

☞ Wire the heaters as required, as shown in Figure 3 - Figure 5 and Figure 10 - Figure 12.

Smart supports the following heating methods:

- Variable heat
- Floor heat
- Room heat

6.2.1 Variable heat

The following section details the Variable Heater parameters:

1. Go to *System > Analog Output 2*.
2. Set the output as **Variable Heat**.
3. Go to *Settings > Variable Heat*.
4. Define the following parameters.
 - **H. On:** Heater starts operating below this temperature.
 - **H. Off:** Heater ceases operating above this temperature.
 - **H. Band:** The controller builds a curve of minimum and maximum operation temperatures, from ON time until [ON time + band]. Below [ON time + band], it operates at maximum capacity.
 - **H. Min.:** Minimum operation (to be calculated on band curve).
 - **H. Max.:** Maximum operation (to be calculated on band curve).
 - **H. Sens:** Choose average temperature, or which sensor to assign to the heater. If a sensor is selected, it is removed from the average temperature calculation.
 - **Min/Max Vlt:** Define the heater's minimum/maximum possible voltage.

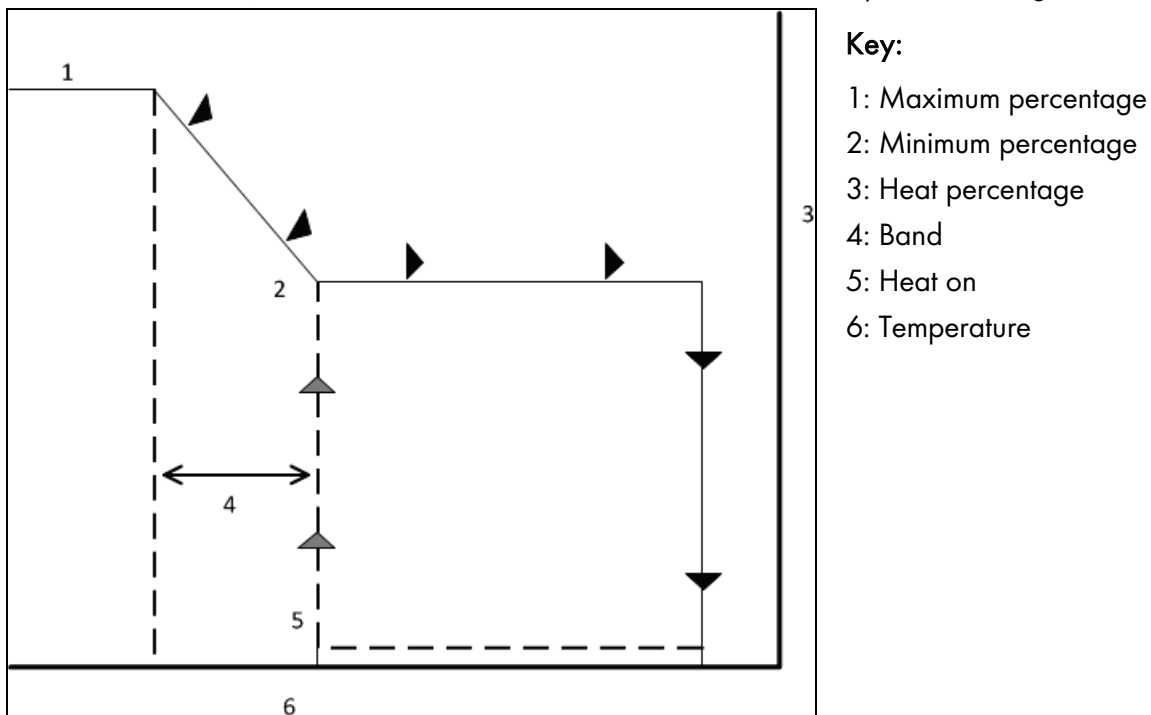

Figure 23: Heat Scheme

6.2.2 Floor heat

The following section details the Floor Heater parameters.

1. Go to *System > Relay 1*.
2. Set the output as **Heat 2**.
3. Go to *Settings > Heat 2 (Floor)*.
4. Define the following parameters.
 - **H. On**: The temperature differential to turn on the Floor Heater.
 - **H. Off**: The temperature differential to turn off the Floor Heater.
 - **H. Sens**: Choose average temperature, or which sensor to assign to the Heater. If a sensor is selected, it is removed from the average temperature calculation.

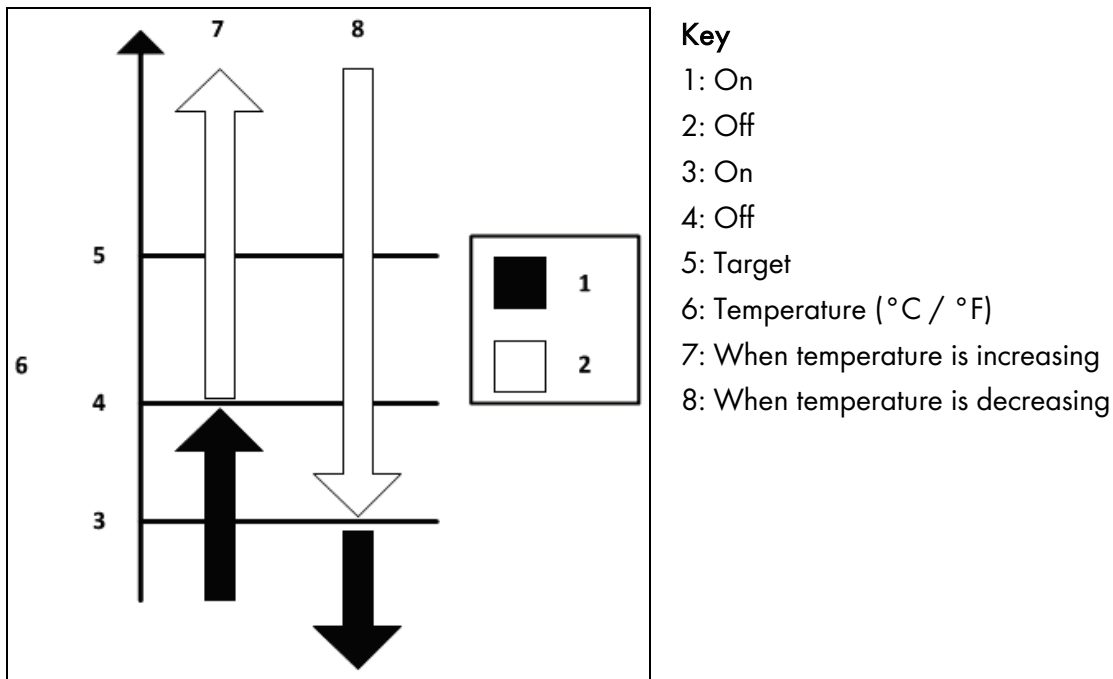
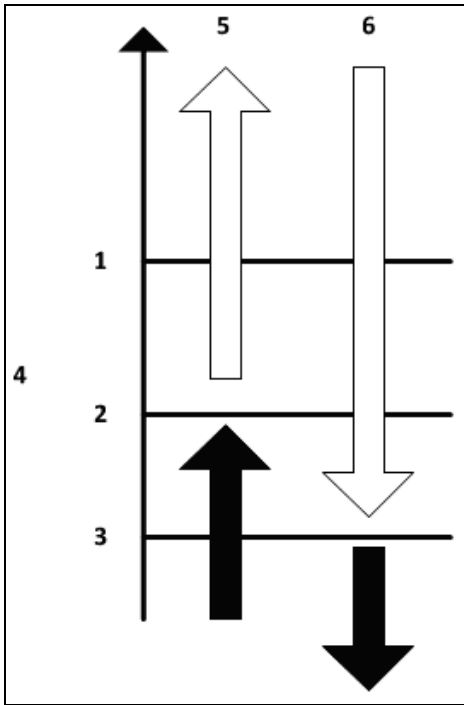

Figure 24: Floor Heater Scheme

6.2.3 Room heat

The following section details the Room Heat parameters:

1. Go to *System > Relay 2*.
2. Set the output as **Heat 3**.
3. Go to *Settings > Heat 2 (Floor)*.
4. Define the following parameters.
 - **H. ON**: The temperature differential to turn on the Room Heater.
 - **H. OFF**: The temperature differential to turn off the Room Heater.





Key:

- 1: Target
- 2: Off
- 3: On
- 4: Temperature (°C / °F)
- 5: When temperature is increasing
- 6: When temperature is decreasing

Figure 25: Room Heat Scheme

7 Technical data

Input Power Voltage	<ul style="list-style-type: none"> • One phase, 230 VAC • 0.1 Amp, 50-60Hz
Relay Loads	8/10 x 5.0 Amps, 250 Volts
Analog Inputs	<ul style="list-style-type: none"> • 3 temperature inputs • 1 humidity input • 2 potentiometers (for feedback on curtain position) • 12 VDC for humidity • 0.1 A
Digital Inputs	<ul style="list-style-type: none"> • 5 ma @ 5 volts, dry contact • 2 inputs (wind speed, water meter)
Operating Temperature Range	0°C to 50°C (32°F to 125°F)
Enclosure	Water and Dust Tight
Fuses	Main fuse: 0.100 Amps, 250 volts
Variable Fan Fuse	15A
Relay Fuse	5A
Variable Speed	Resistive Load Maximum Current: 10 Amp
Fan Maximum Power	<ul style="list-style-type: none"> • 230 V: 2 HP • 110 V: 1 HP
Certification	  

8 Electrical grounding for controllers

Electrical equipment can be destroyed or slowly damaged by voltage spikes, lightning hits, etc. Proper electrical grounding in combination with the SMART internal protections is essential to protect the system, reduce the risk of damage and prolong its lifetime. Correct selection and installation of equipment protects your system and reduce the risk of human injury.

Proper grounding provides an easy path for electrical current to return to its source. A grounding system should tie all non-current carrying conductors to earth ground (0 volts). The grounding system should present a minimum resistance to current flow. Make sure all items used are in proper condition; for example, a corroded wire clamp attaching a ground wire to a ground rod might add 100 ohms or more resistance to a system. Less than 5 ohm is considered a good ground.

8.1 Ground rods

Ground rods are used to efficiently connect the system to earth where current may be dissipated in the soil.

- Material: Ground rods should be copper clad or galvanized steel.
- Diameter: Minimum 5/8", preferably 3/4". Generally the larger the rod diameter, the lower its resistance to current flow.
- Length: Minimum 2.5 meters (8 feet), preferably 3-meter (10-foot). A longer ground rod reaches a soil with higher moisture content. Moist soil carries current much better than drier soil.
- Single grounding: It is important that there is only one grounding location where a rod or series of rods are connected to each other using a ground wire.
- Independent ground rods increases the risk of current, from a lightning strike for example, being dissipated through one rod and reentering the system through an adjacent rod.
- Location: Close to the main circuit breaker panel and in moist soil. For example in an area that is usually wet from a drip or a low spot where water drains. Make sure the area is well protected from damage by lawnmowers, tractors, etc.
- Rod installation: Drive the rod into the earth until about 10 cm (4 inches) is left above grade. If it is impossible to drive the rod to the proper depth, it is acceptable to lay the rod horizontally, 80 cm (2.5 feet) below grade.
- In case the rod is exposed to damage, for example by lawnmowers or tractors, it can be installed in a hole, about 20 cm (8 inches) deep so that the rod is about 10 cm under grade and 10 cm above hole level.



The National Electric Code (NEC) mandates two ground rods unless you can show less than 10 ohms resistance with one rod.

8.2 Ground wire

The ground wire is a large copper wire that connects the main circuit breaker panel to the ground rod.

- Material: Ground rods should be copper clad or galvanized steel.
- Diameter: Typically, 16 mm (6-gauge) copper wire is sufficient. If the wire run is greater than 20 feet, 20 mm (4-gauge) wire should be used.
- Length: Minimum 2.5 meters (8 feet), preferably 3-meter (10-foot). A longer ground rod reaches a soil with higher moisture content. Moist soil carries current much better than drier soil.

The ground wire should be protected from damage by lawnmowers, tractors, etc. It should be buried minimum 15 cm (6 inches) underground for protection and enter the house as soon as possible. It is important that the wire not be cut; it should remain continuous.

8.3 Ground clamps

Ground wires should not be merely wrapped around a ground rod. Ground clamps are used to attach a ground wire to a ground rod. The most common clamp is an acorn clamp. Make sure the ground clamps you select are rated for outdoor use. Do not use pipe clamps rated for inside water lines or hose clamps to attach the ground wire.



Figure 26: Ground Connection

8.4 What should be grounded?

Any equipment that is or could become energized, even accidentally, should be grounded. Current from lightning strikes objects in a random fashion. Accounts of lightning strikes reveal scenarios most of us could not predict.

Electric circuits should be wired with a 3-wire conductor consisting of hot, neutral and grounding wires. The grounding wire should be attached cleanly and securely to devices or systems to be grounded. The other end of the grounding wire should be attached to the ground bus on the main panel.

9 Troubleshooting

Display	Problem	Possible Cause	Possible Solution
Error	Error message on the main screen (instead of Temp indication); the system does not read any temperature sensor	Temperature sensor not connected	Connect sensor properly
		Temperature sensor's terminals or wires not connected, or not properly connected.	Connect terminals and wires properly. Unbolt the screw, make sure the plate is upwards
		Wrong terminals connected	Connect appropriate terminals
		Flat cable not properly connected	Connect flat cable properly
Sensor Fail	Faulty sensor	Sensor not connected	Connect sensor properly
		Sensor's terminals are not connected, or not properly connected	Connect terminals and wires properly. Unbolt the screw, make sure the plate is upwards
		Wrong terminals connected	Connect appropriate terminals
		Flat cable not properly connected	Connect flat cable properly
-	Variable speed, heat or inlets do not reach maximum or minimum levels	Variable speed, heat, or inlets are not set to required levels	Go to Settings menu, and set the required level using the OK and P keys
TX and RX LEDs constantly turned ON or OFF	No communication to the unit	Wiring problem	Check the wiring connections
TX and RX LEDs blinking	No communication to the unit	No unit number is allocated	Allocate unit number
		Unit number is not unique on the network	Make sure the unit number is unique
		PC and controller do not use the same baud rate	Verify PC and controller use the same baud rate
		Baud rate too high (relative to cable length)	If all parameters are valid, reduce baud rate

Display	Problem	Possible Cause	Possible Solution
-	Output relay or variable fan not working	Settings are not correct	Refer to the Test section in order to check settings manually. If the settings are valid, it is a hardware problem
		Faulty card, fuse, connections or external device	Replace faulty part
No display	Unit does not operate	No input voltage	Contact authorized electrician
		Main fuse burned	Check the main fuse (F9 & F6)
		Faulty flat cable	Replace the flat cable
-	Unclear display or no display	Contrast is not set properly	Set contrast (R2) properly
-	No LCD display and LED is blinking	LCD or CPU problem	Replace LCD or CPU card
Alarm or N/A	Sensor fail	Sensor disconnected or not properly connected	Connect sensor properly

CAUTION In case of hardware problems, do not open the box. Contact an authorized electrician.

10 Warranty

Warranty and technical assistance

Munters products are designed and built to provide reliable and satisfactory performance but cannot be guaranteed free of faults; although they are reliable products they can develop unforeseeable defects and the user must take this into account and arrange adequate emergency or alarm systems if failure to operate could cause damage to the articles for which the Munters plant was required: if this is not done, the user is fully responsible for the damage which they could suffer.

Munters extends this limited warranty to the first purchaser and guarantees its products to be free from defects originating in manufacture or materials for one year from the date of delivery, provided that suitable transport, storage, installation and maintenance terms are complied with. The warranty does not apply if the products have been repaired without express authorization from Munters, or repaired in such a way that, in Munters' judgment, their performance and reliability have been impaired, or incorrectly installed, or subjected to improper use. The user accepts total responsibility for incorrect use of the products.

The warranty on products from outside suppliers fitted to Smart, (for example Smart's thermostats, sensors, cables, etc.) is limited to the conditions stated by the supplier: all claims must be made in writing within eight days of the discovery of the defect and within 12 months of the delivery of the defective product. Munters has thirty days from the date of receipt in which to take action, and has the right to examine the product at the customer's premises or at its own plant (carriage cost to be borne by the customer).

Munters at its sole discretion has the option of replacing or repairing, free of charge, products which it considers defective, and will arrange for their despatch back to the customer carriage paid. In the case of faulty parts of small commercial value which are widely available (such as bolts, etc.) for urgent despatch, where the cost of carriage would exceed the value of the parts, Munters may authorize the customer exclusively to purchase the replacement parts locally; Munters will reimburse the value of the product at its cost price.

Munters will not be liable for costs incurred in demounting the defective part, or the time required to travel to site and the associated travel costs. No agent, employee or dealer is authorized to give any further guarantees or to accept any other liability on Munters' behalf in connection with other Munters products, except in writing with the signature of one of the Company's Managers.

WARNING: *In the interests of improving the quality of its products and services, Munters reserves the right at any time and without prior notice to alter the specifications in this manual.*

The liability of the manufacturer Munters ceases in the event of:

- dismantling the safety devices;
- use of unauthorized materials;
- inadequate maintenance;

- use of non-original spare parts and accessories.

Barring specific contractual terms, the following are directly at the user's expense:

- preparing installation sites;
- providing an electricity supply (including the protective equipotential bonding (PE) conductor, in accordance with CEI EN 60204-1, paragraph 8.2), for correctly connecting the equipment to the mains electricity supply;
- providing ancillary services appropriate to the requirements of the plant on the basis of the information supplied with regard to installation;
- tools and consumables required for fitting and installation;
- lubricants necessary for commissioning and maintenance.

It is mandatory to purchase and use only original spare parts or those recommended by the manufacturer.

Dismantling and assembly must be performed by qualified technicians and according to the manufacturer's instructions.

The use of non-original spare parts or incorrect assembly exonerates the manufacturer from all liability.

Requests for technical assistance and spare parts can be made directly to the nearest Munters office. A full list of contact details can be found on the back page of this manual.

Munters Israel

18 HaSivim Street

Petach-Tikva 49517, Israel

Telephone: +972-3-920-6200

Fax: +972-3-924-9834

support@munters.co.il



www.munters.com

Australia Munters Pty Limited, Phone +61 2 8843 1594, **Brazil** Munters Brasil Industria e Comercio Ltda, Phone +55 41 3317 5050, **Canada** Munters Corporation Lansing, Phone +1 517 676 7070, **China** Munters Air Treatment Equipment (Beijing) Co. Ltd, Phone +86 10 80 481 121, **Denmark** Munters A/S, Phone +45 9862 3311, **India** Munters India, Phone +91 20 3052 2520, **Indonesia** Munters, Phone +62 818 739 235, **Israel** Munters Israel Phone +972-3-920-6200, **Italy** Munters Italy S.p.A., Chiusavecchia, Phone +39 0183 52 11, **Japan** Munters K.K., Phone +81 3 5970 0021, **Korea** Munters Korea Co. Ltd., Phone +82 2 761 8701, **Mexico** Munters Mexico, Phone +52 818 262 54 00, **Singapore** Munters Pte Ltd., Phone +65 744 6828, **South Africa and Sub-Sahara Countries** Munters (Pty) Ltd., Phone +27 11 997 2000, **Spain** Munters Spain S.A., Phone +34 91 640 09 02, **Sweden** Munters AB, Phone +46 8 626 63 00, **Thailand** Munters Co. Ltd., Phone +66 2 642 2670, **Turkey** Munters Form Endüstri Sistemleri A.Ş, Phone +90 322 231 1338, **USA** Munters Corporation Lansing, Phone +1 517 676 7070, **Vietnam** Munters Vietnam, Phone +84 8 3825 6838, **Export & Other countries** Munters Italy S.p.A., Chiusavecchia Phone +39 0183 52 11