

Manual for use and maintenance

RLD



RLD

Light Dimmer

Ag/MIS/UmGB-2568-04/18 Rev 1.1
P/N: 116036

 Munters

RLD

Manual for use and maintenance

Revision: 1.1 of 016/2022

Ag/MIS/UmGB-2568-04/18 Rev 3.4 (MIS)

Product Software: Version 3.00/4.01

This manual for use and maintenance is an integral part of the apparatus together with the attached technical documentation.

This document is destined for the user of the apparatus: it may not be reproduced in whole or in part, committed to computer memory as a file or delivered to third parties without the prior authorization of the assembler of the system.

Munters reserves the right to effect modifications to the apparatus in accordance with technical and legal developments.

Index

<i>Chapter</i>		<i>page</i>
1	INTRODUCTION	5
1.1	Disclaimer	5
1.2	Introduction	5
1.3	Notes	5
2	SAFETY ASPECTS	6
3	INTRODUCTION TO THE RLD	6
3.1	Device description	6
3.2	Software Versions	7
3.3	Abbreviations and Terms	7
3.4	User interface	8
4	USING THE RLD	9
4.1	Preliminary setup options	9
4.1.1	System parameter 1 - bulb type	9
4.1.2	System parameter 2 - channel	9
4.1.3	System parameter 3 - low limit	10
4.1.4	System parameter 4 - brightness restriction	10
4.1.5	System parameter 5 - ignition pulse	10
4.2	Bright mode	10
4.3	Manual dim mode	10
4.4	Auto mode	10
4.5	Performing a Cold Start	11
5	SPECIFICATIONS	12
5.1	Environmental protection	12
6	INSTALLATION	13
6.1	RLD wiring diagram	13
6.1.1	RLD 7.2 wiring	14
6.1.2	RLD 14 wiring	16
6.2	Configuring the channel levels	17
6.2.1	Using an analog output card	17
6.2.2	Using a communication card	19
7	TROUBLESHOOTING	20
8	WARRANTY	21

1 Introduction

1.1 Disclaimer

Munters reserves the right to make alterations to specifications, quantities, dimensions etc. for production or other reasons, subsequent to publication. The information contained herein has been prepared by qualified experts within Munters. While we believe the information is accurate and complete, we make no warranty or representation for any particular purposes. The information is offered in good faith and with the understanding that any use of the units or accessories in breach of the directions and warnings in this document is at the sole discretion and risk of the user.

1.2 Introduction

Congratulations on your excellent choice of purchasing an RLD!

In order to realize the full benefit from this product it is important that it is installed, commissioned and operated correctly. Before installation or using the unit, this manual should be studied carefully. It is also recommended that it is kept safely for future reference. The manual is intended as a reference for installation, commissioning and day-to-day operation of the Munters equipment.

1.3 Notes

Date of release: July 2010

Munters cannot guarantee to inform users about the changes or to distribute new manuals to them. All rights reserved. No part of this manual may be reproduced in any manner whatsoever without the expressed written permission of Munters. The contents of this manual are subject to change without notice.

2 Safety aspects

CAUTION The COM connection for communications is not the shield wire. The COM, RX and TX wires must connect to each other at all controllers.

WARNING! ONLY an authorized electrician may install the RLD. Power must be disconnected to avoid electrical shock and damage. To avoid exposing the RLED to harmful gases or high humidity, it is recommended to install it in the service room.

3 Introduction to the RLD

The RLD units enable controlling the light and brightness in the poultry pen. Munters' Platinum, AC-2000 and Super Guard controllers support the RLD. This manual is meant to be used by either farmers or authorized personnel who own a poultry pen.

3.1 Device description

The RLD 7.2 and RLD 14 are two independent channels device controlling all light functions inside the house. These dimmers have unique features such as stable operation in low brightness levels and high flexibility.

Main features:

- Two independent channels
- Programmable brightness control by analog signal 0 - 10 VDC and communication line from the controller
- Automatic settings save for each mode.
- Maximal output power for one channel:
 - 230 VAC, 7200 VA (RLD-14)
 - 110 VAC, 3600 VA (RLD-7.2)
- Manual brightness control
- *Automatic settings recovery after power failure
- Minimum and maximum light intensity settings
- Automatic shut down timer.

NOTE *The settings are immediately saved after being defined

3.2 Software Versions

Munters' RLD currently supports two software versions:

- Version 3.0 supports:
 - CPU card version 1.3.1 (refer to Figure 7)
- Version 4.01 supports:
 - CPU card version 2.0 (refer to Figure 6)

3.3 Abbreviations and Terms

Terms	Meaning Description
LED	Light Emitting Diode: An electronic device used to indicate the status of various functions on the front panel.
Default	A value permanently stored in memory and is used to define the parameter in the absence of a user-defined value.
Restart	The procedure that aimed to renew the device state.
Cold Start	The procedure that restores default (factory) values of the parameters
"bu"	Bulb: This parameter defines the bulb type (Incandescent, LED, fluorescent, cold cathode)
"ch"	Channel: This parameter can receive values between 0 - 8 since it can be connected to eight matching lines of the Platinum / AC-2000 controller.
"Lo"	Low: This parameter prevents lamps from burning out through defining a minimum brightness limit. This value cannot be higher
"br"	Brightness Restriction: By this parameter one can restrict the upper limit of the output voltage. It's values can be within "On" (100) and "0" (0%)

3.4 User interface

The following section details the keypad.

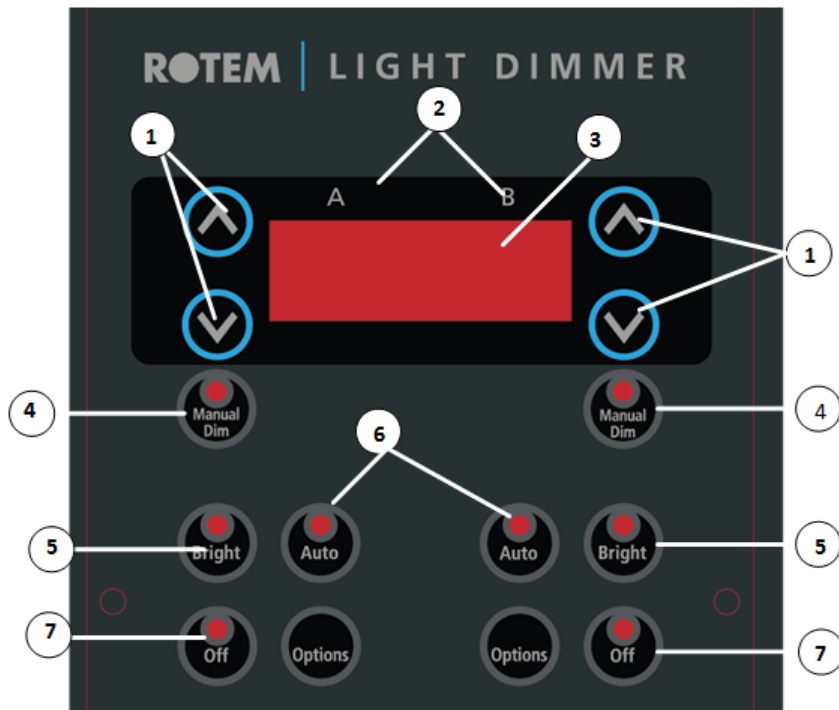

Figure 1: Front Panel

Note that the keypad is divided into two channels ('A' and 'B'), press the appropriate channel buttons. The relevant LED indicates the current active mode.

1. **Cursor keys:** These keys change values of output voltage (in percentage)
2. **Channels:** This specifies which channel is being dealt with. Note that the buttons are duplicated since each one is dedicated to each channel separately.
3. **Display:** Both values of voltage and parameters are displayed here.
4. **Manual Dim:** Pressing this button sets the RLD channel to manual mode. In manual mode you can set the light percentage using the arrow keys. Verify that you are changing the required channel.
5. **Bright:** Pressing this button gradually increases the channel to full brightness for a period of 20 minutes. Adjust the time period by pressing the up/down cursor keys. The display shows the remaining amount of time before the light begins to turn off. When this period ends, the decrease in light is gradual.
6. **Auto:** Pressing this button utilizes the analog input card 0-10 V output or communication card and is controlled via a lighting table program.
7. **Off:** Pressing this button gradually reduces the channel to 0% light intensity.

NOTE *The lights go off at the Lo setting.*

8. **Options:** Press this button to view the RLD system parameters menu.

4 Using the RLD

The following sections detail how to use the RLD.

After setting the parameters, RLD automatically backs them up. In cases when the power shuts down and goes back on, the controller continues operating as in its last saved state.

4.1 Preliminary setup options

Press **Options** of either channel for three seconds to enter the system parameters menu. The first parameter is "bu." To navigate to the other three parameters, press the "Options" button. The sequence order of parameters to appear is as follows: **bu** → **ch** → **Lo** → **br**

NOTE The "**Options**" button is also used to exit from this menu.

4.1.1 System parameter 1 – bulb type

The "**bu**" parameter defines the bulb type. It is important to define the type of bulb since each type has different electrical properties. The options are:

- **Lb**: Incandescent (Tungsten)
- **CC**: Cold Cathode
- **FL**: Fluorescent

CAUTION To ensure proper operation, cold cathode and and fluorescent lamp infrastructures require the installation of one incandescent lamp in line with these lamps.

NOTE If you change the bulb type, the **Low Limit** and **Ignition Pulse** parameters return to their default settings.

4.1.2 System parameter 2 – channel

The "**ch**" (Channel) parameter sets the connection mode. **0** represents connection via voltage-controlled mode using 0-10 VDC Analog input and **1-8** represents connection via the controller's communication feature.

- **Connecting via 0 – 10 VDC analog input**: Set the parameter to **0**. Refer to Using an analog output, page 17 for wiring information.
- **Connecting via the controller's communication feature**: Set the parameter from 1 – 8. Each channel must be set to a different number (for example 01 and 02). Refer to Using a communication card, page 19 for further details regarding numbering.

NOTE The unit must be set to Auto Mode when working with a controller (refer to Auto mode, page 10).

4.1.3 System parameter 3 – low limit

The "Lo" parameter defines the minimum brightness limit (0%-99%). This parameter prevents lights burning out; the light only begins to operate when the brightness level reaches and exceeds this value. The light ceases to operate once the intensity level is 10% below the value in this parameter (for example: when set to 20% the light turns off at 18%). Default: 20%

NOTE The *Lo setting* cannot be *higher* than the *br setting*. The *br setting* cannot be *lower* than the *Lo setting*.

4.1.4 System parameter 4 – brightness restriction

This parameter restricts the maximal value of brightness according to the user's setting. The default value is "On" (100%). Adjust the desired limit through use of the "UP" and "DOWN" buttons. This feature is useful when there is no need for the maximal brightness and helps to save power.

4.1.5 System parameter 5 – ignition pulse

When going from 0% brightness to any other brightness level, **some cold cathode** and **fluorescent** bulbs require full power for a brief period of time (milliseconds). This option supplies the required power. Since there are a large number of models on the market, each model having its own specifications, each user must test his model to verify if an ignition pulse is required and how long the pulse needs to run

- **Default:** None
- **1 – 5:** Pulse length. 1 is the shortest and 5 is the longest.

NOTE Software versions 4.01 and higher support this option.

4.2 Bright mode

The **Bright** mode gradually increases the light intensity to the maximum value set in the "br" parameter. By default this process takes 20 minutes, but it can be adjusted through the "UP" and "DOWN" cursor keys during **Bright Mode** operation. The feature is useful, for example, when a farmer needs to have the light ON for a specific period of time in the poultry house. After that time period, the light dims gradually down to the previous value.

NOTE The system returns to the previous mode, at the point where it left off.

For continuous operation, set the unit to **Manual Dim Mode**.

4.3 Manual dim mode

Pressing "**Manual Dim**" enters the device into "Manual Dim" mode. The display changes and indicates the voltage percentage value for that channel. Manual Dim is used to override the Auto Mode settings.

In manual mode the user changes the light brightness by pressing the **UP** and **DOWN** arrow keys.

4.4 Auto mode

Pressing the "**Auto**" button enables connecting the RLD to a controller.

There are two ways to connect the RLD to a controller:

- Via an analog output card 0-10 VDC (All Munters Controllers)
- Via a communication card (Platinum Controller only)

CAUTION Connect the RLD to a controller using one option only! Connecting the RLD using both methods together results in faulty light levels.

Refer to Configuring the channel levels, page 17 for information of connecting the unit to a controller.

4.5 Performing a Cold Start

Perform Cold Start to return the RLD to its default state:

1. Unplug the unit.
2. Reapply power; **simultaneously** press both arrow buttons.
The unit has been reset.

NOTE To check the software version, press the **RESET** button.

5 Specifications

Input Voltage	
• RLD 14	One/Two phase, 230 VAC 50/60 Hz
• RLD 7.2	One, 110 VAC 50/60 Hz
Output Maximal Load (Per Channel)	30 Amps
Maximal Power (Per Channel)	
• RLD 14	230 VAC, 7200 VA
• RLD 7.2	110 VAC, 3600 VA
Operating Temperature Range	0° to 50° C (32° to 122° F)
0 -10 VDC Analog Input Impedance	10 KOhm
Humidity	85%
Enclosure	Water and dust tight (IP66)
Fuses	Main Fuse: 315 mA slow blow

5.1 Environmental protection



Recycle raw materials instead of disposing as waste. The controller, accessories and packaging should be sorted for environmental-friendly recycling. The plastic components are labeled for categorized recycling.

6 Installation

WARNING! *ONLY an authorized electrician may install the RLD. Power must be disconnected to avoid electrical shock and damage. To avoid exposing the RLD to harmful gases or high humidity, it is recommended to install it in the service room.*

NOTE *Installation Category (Over voltage Category) II*

CAUTION *The wires that supply power to the RLD schematics also supply power to the light. The cross-section of the copper cable must not be less than 10 mm².*

1. Mount the RLD on the wall, using the four supplied screws through the mounting holes.
2. Place the required cables through the cable holders at the bottom of the unit. Connect the wires according to the wiring diagrams (see below).
3. To connect the "0 - 10" volt DC wire to the controller, use two conductor #18 - #24 gauge cable. Connect the minus (-) to the Common terminal on the controller terminal block, and the plus (+) to terminal #4 (0 - 10 volt output).

NOTE *Make sure the correct wires for the load are in use.*

4. Close the RLD enclosure lid carefully and tightly.
5. Use RTV silicon or an equivalent sealant to seal the cable holders.
6. After installation has been completed, operate the RLD (and the controller, if connected) for a few hours and check for proper operation.

6.1 RLD wiring diagram

The following diagrams show how to connect the RLD to:

- Power source
- Lighting

The particular wiring depends on the number of phases:

- RLD 7.2 (single phase)
- RLD 7.2 (triple phase)
- RLD 14 (single phase)
- RLD 14 (triple phase)

Refer to Configuring the channel levels, page 17 for instructions on wiring the unit to a controller.

6.1.1 RLD 7.2 wiring

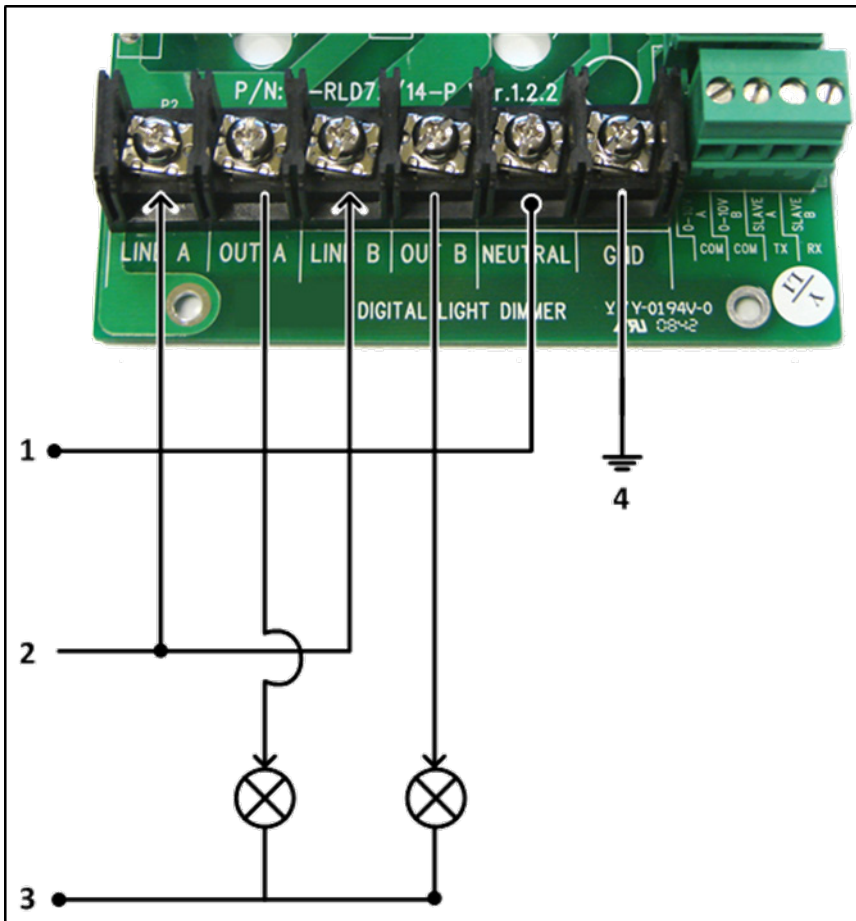

Figure 2: RLD 7.2 115V Single Phase Wiring

- Key:
 - 1: Neutral
 - 2: 115 VAC
 - 3: Neutral
 - 4: Safety ground

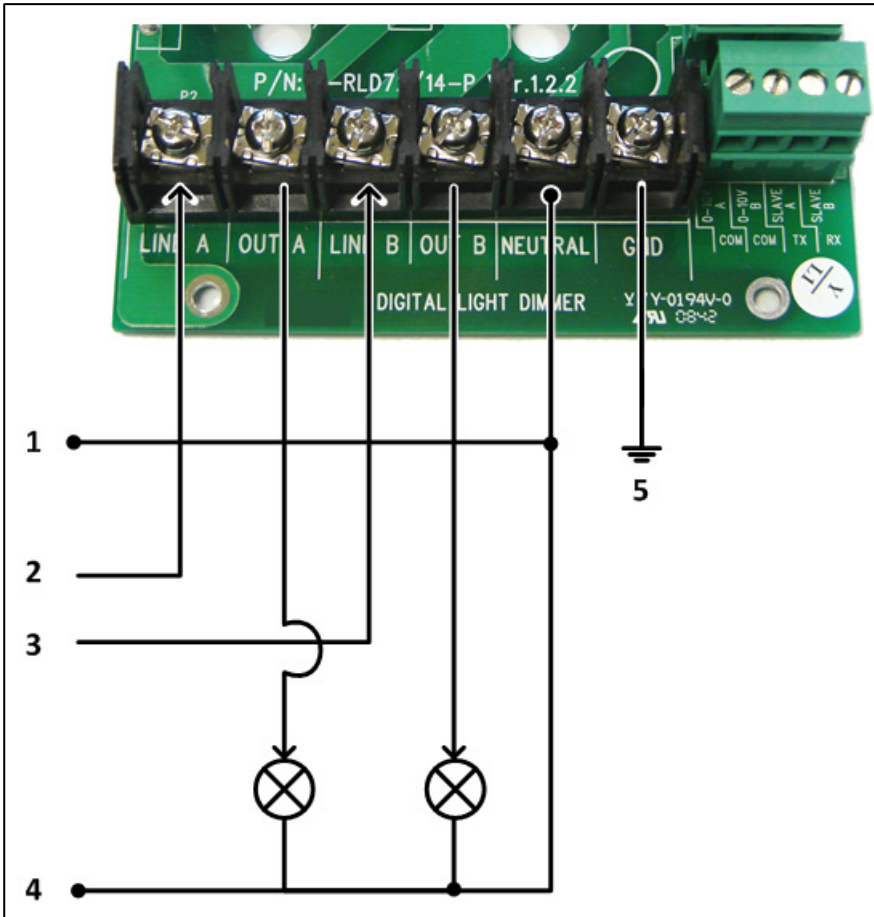

Figure 3: RLD 7.2 115V Two Phase Wiring

- Key:
 - 1: Neutral
 - 2: 115V VAC Phase A
 - 3: 115V VAC Phase B
 - 4: Neutral
 - 5: Safety ground

6.1.2 RLD 14 wiring

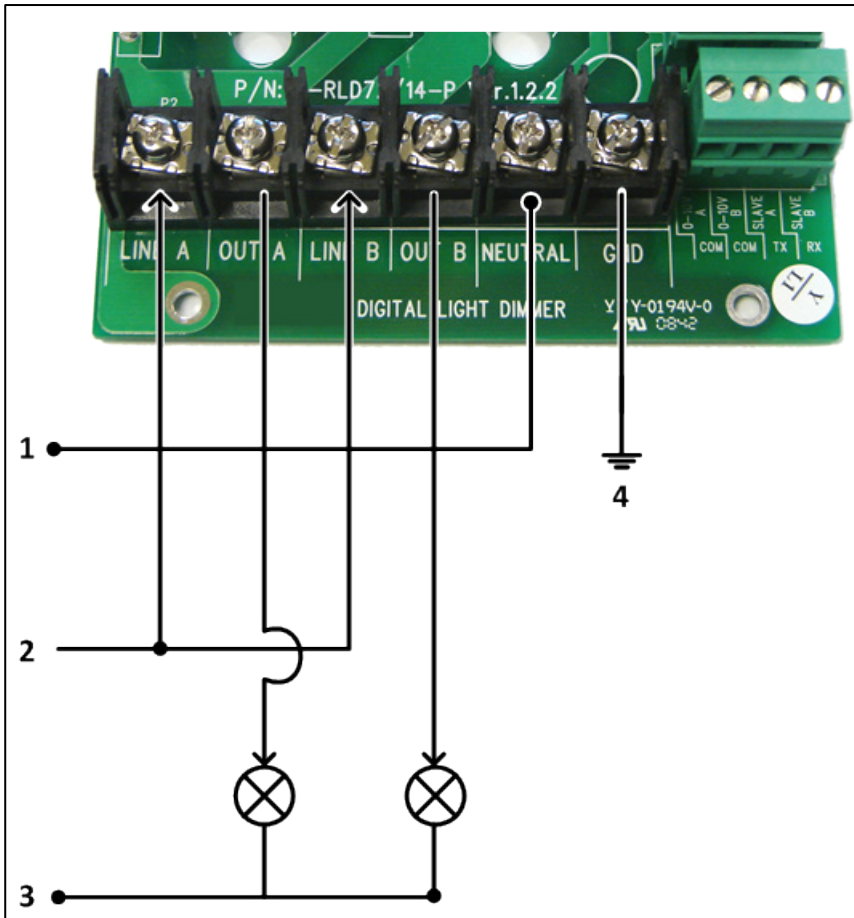

Figure 4: RLD 230V Single Phase Wiring

- Key:
 - 1: Neutral
 - 2: 230 VAC
 - 3: Neutral
 - 4: Safety ground

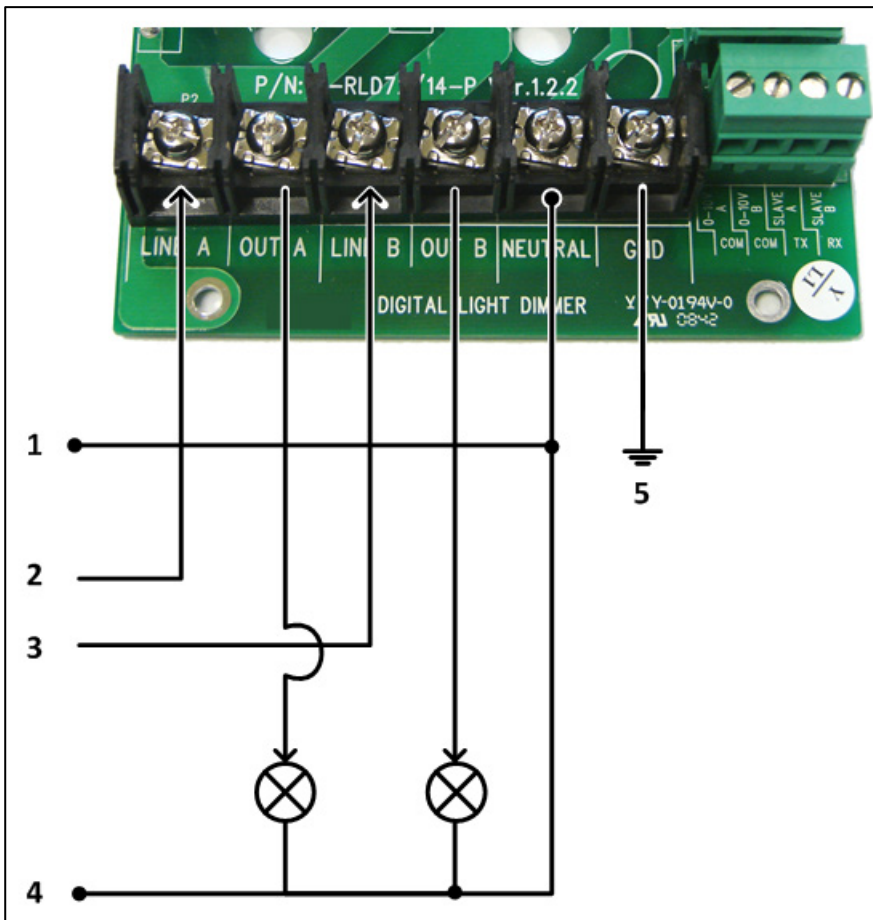

Figure 5: RLD 230V Two Phase Wiring

- Key:
 - 1: Neutral
 - 2: 230 VAC Phase A
 - 3: 230 VAC Phase B
 - 4: Neutral
 - 5: Safety ground

6.2 Configuring the channel levels

The following sections detail how to configure the channel levels.

- Using an analog output card, page 17
- Using a communication card, page 19

6.2.1 Using an analog output card

NOTE Verify that parameter "ch" is set to "0" (refer to System parameter 2 – channel, page 9).

1. Connect the 0 – 10 VDC (+) and COM (-) wires from the external device to the terminal ports "0-10V A", "0-10V B" and COM (Figure 6 and Figure 7).

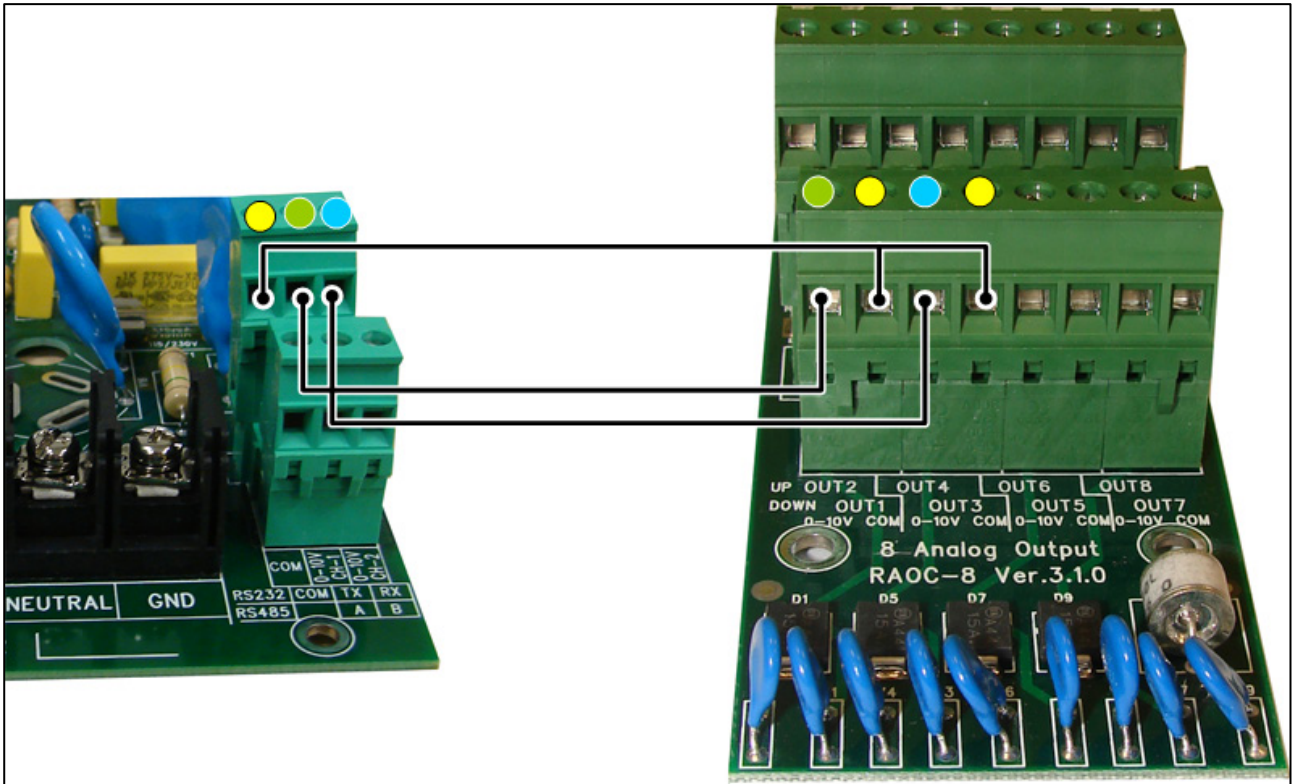

Figure 6: RLD (Board Version 2.1) to RAOC-8 (Analog Output) Wiring Diagram

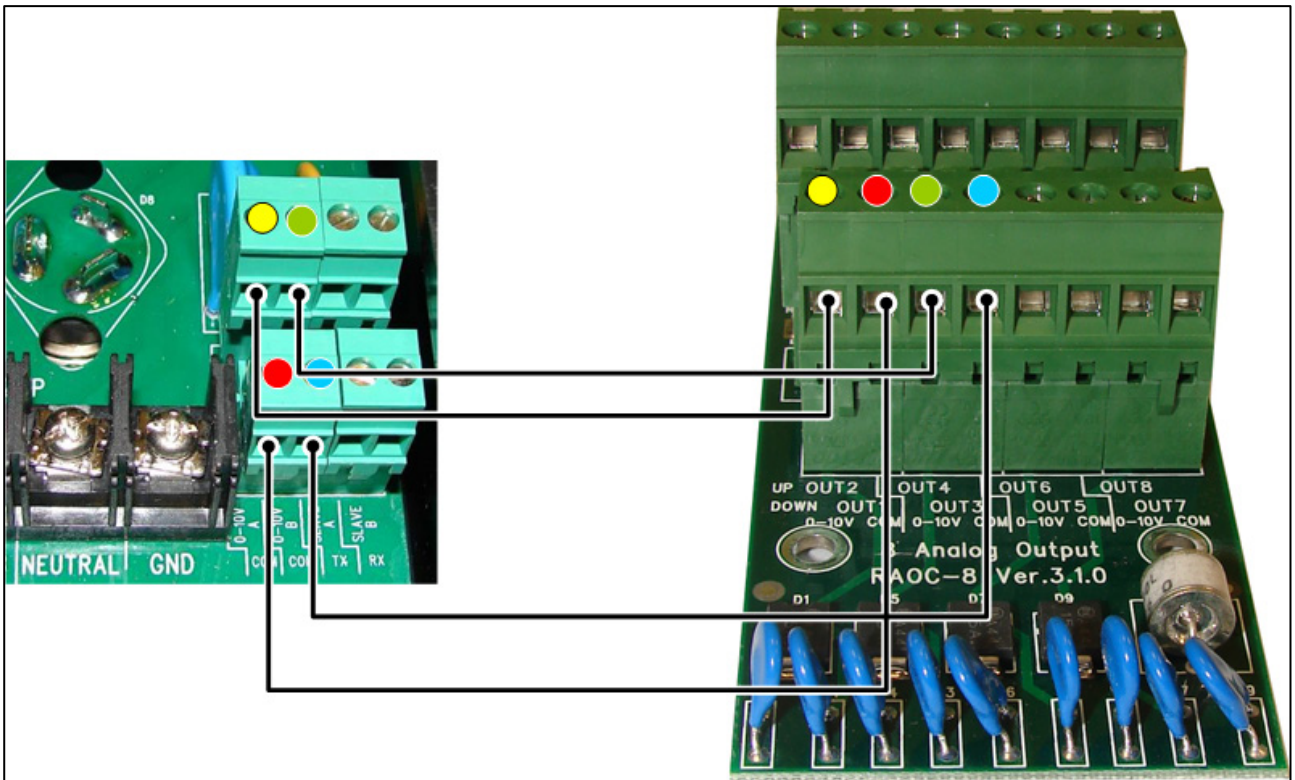
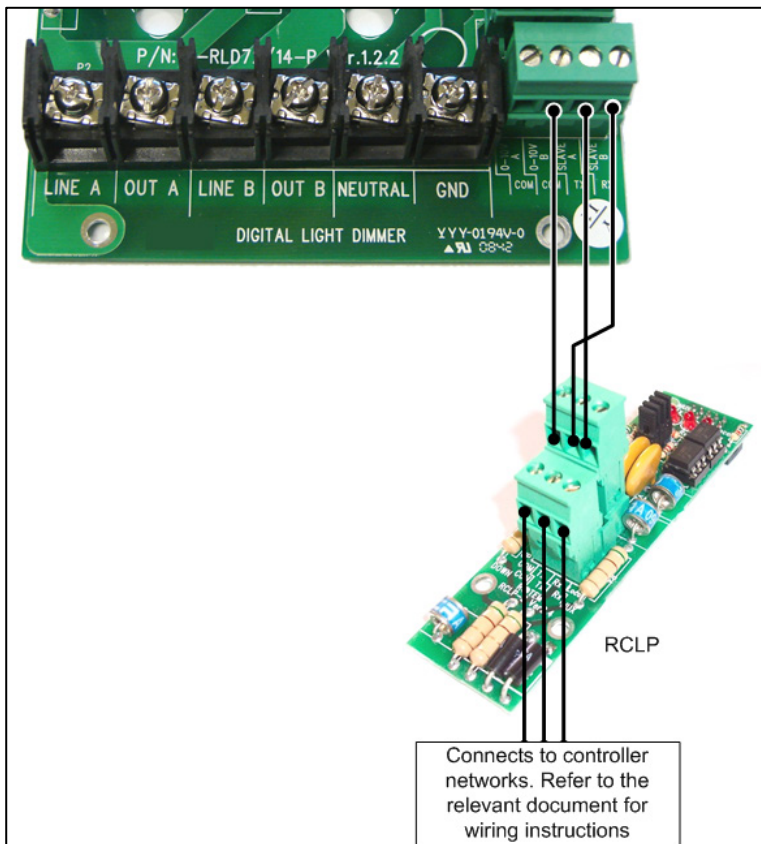

Figure 7: RLD (Board Version 1.3.1) to RAOC-8 (Analog Output) Wiring Diagram

2. To control both channels simultaneously, short "0-10V A" and "0-10V B".
3. To configure the channel levels go to the:
 - Analog output table (Platinum and Super Guard/Pig Guard)
 - System parameters (AC-2000)

6.2.2 Using a communication card

1. Connect the RLD to an RCLP card.



NOTE Verify that parameter "*ch*" is set to "1 - 8" (refer to System parameter 2 - channel, page 9).

2. Configure the channels. There are two numbering options:
 - Different numbers to each channel, with up to 8 different channels (when using multiple RLD units).
 - Same number for more than one channel if you require the same behaviors from these channels.

For example, two RLD units can control four channels using the communication line:

- 1st channel (A1) #1: 20%
- 2nd channel (A2) #2: 10%
- 3rd channel (B1) #2: 10% (same as A2)
- 4th channel (B2) #3: 90%

NOTE To control both channels simultaneously, short the terminals "0-10V A" and "0-10V B".

7 Troubleshooting

CAUTION To ensure proper RLD operation, do not connect any inductive devices to the output (for example transformers, reactors, chokes).

#	Problem Description	Troubleshooting
1	When Power is connected the seven-segments and LEDs indicate nothing.	<ul style="list-style-type: none">• Check the power.• Check the main fuse F3 and F1 (when working with 230 VAC).• Check +5V.• Check flat cable connection.
2	Power is ON, but there is no Output when working in "AUTO" mode with: "0-10V" control voltage RX, TX communication lines	<ul style="list-style-type: none">• Make sure the "+" and "COM" of "0-10V" cable is connected correctly. Set 5V from controller and measure this value at the RLD terminal.• Make sure the RX, TX are connected correctly (interchange RX and TX).
3	A blinking is observed when working at low voltage levels.	Make sure there are no inductive devices (for example transformers and power coils) load.

8 Warranty

Warranty and technical assistance

Munters products are designed and built to provide reliable and satisfactory performance but cannot be guaranteed free of faults; although they are reliable products they can develop unforeseeable defects and the user must take this into account and arrange adequate emergency or alarm systems if failure to operate could cause damage to the articles for which the Munters plant was required: if this is not done, the user is fully responsible for the damage which they could suffer.

Munters extends this limited warranty to the first purchaser and guarantees its products to be free from defects originating in manufacture or materials for one year from the date of delivery, provided that suitable transport, storage, installation and maintenance terms are complied with. The warranty does not apply if the products have been repaired without express authorisation from Munters, or repaired in such a way that, in Munters' judgement, their performance and reliability have been impaired, or incorrectly installed, or subjected to improper use. The user accepts total responsibility for incorrect use of the products.

The warranty on products from outside suppliers fitted to RLD, (for example cables, lights, etc.) is limited to the conditions stated by the supplier: all claims must be made in writing within eight days of the discovery of the defect and within 12 months of the delivery of the defective product. Munters has thirty days from the date of receipt in which to take action, and has the right to examine the product at the customer's premises or at its own plant (carriage cost to be borne by the customer).

Munters at its sole discretion has the option of replacing or repairing, free of charge, products which it considers defective, and will arrange for their despatch back to the customer carriage paid. In the case of faulty parts of small commercial value which are widely available (such as bolts, etc.) for urgent despatch, where the cost of carriage would exceed the value of the parts, Munters may authorise the customer exclusively to purchase the replacement parts locally; Munters will reimburse the value of the product at its cost price.

Munters will not be liable for costs incurred in demounting the defective part, or the time required to travel to site and the associated travel costs. No agent, employee or dealer is authorised to give any further guarantees or to accept any other liability on Munters' behalf in connection with other Munters products, except in writing with the signature of one of the Company's Managers.

WARNING! *In the interests of improving the quality of its products and services, Munters reserves the right at any time and without prior notice to alter the specifications in this manual.*

The liability of the manufacturer Munters ceases in the event of:

- dismantling the safety devices;
- use of unauthorised materials;

- inadequate maintenance;
- use of non-original spare parts and accessories.

Barring specific contractual terms, the following are directly at the user's expense:

- preparing installation sites;
- providing an electricity supply (including the protective equipotential bonding (PE) conductor, in accordance with CEI EN 60204-1, paragraph 8.2), for correctly connecting the equipment to the mains electricity supply;
- providing ancillary services appropriate to the requirements of the plant on the basis of the information supplied with regard to installation;
- tools and consumables required for fitting and installation;
- lubricants necessary for commissioning and maintenance.

It is mandatory to purchase and use only original spare parts or those recommended by the manufacturer.

Dismantling and assembly must be performed by qualified technicians and according to the manufacturer's instructions.

The use of non-original spare parts or incorrect assembly exonerates the manufacturer from all liability. Requests for technical assistance and spare parts can be made directly to the nearest [Munters office](#).

