



Agri-Alert 128 Touch

Models:
ALERT SYSTEM
890-00584

Installation and Configuration Manual

895-00677
Version 01

AgriAlert

A BRAND OF
GSI GROUP



All information, illustrations, photos, and specifications in this manual are based on the latest information available at the time of publication. The right is reserved to make changes at any time without notice.

Contents

Chapter 1	General Overview	7
	7
	System Overview	7
	What to Look for When you Receive Your System	8
	Terms of Use	8
	Telecommunication Information	9
	General Safety Precautions and Usage	12
Chapter 2	Getting Started	15
	Special Tools Needed for Installation	15
	Guidelines on the Ideal Location for Installation	15
	Correctly Supporting and Routing Cables	16
	Grounding the System	18
Chapter 3	Basic Connections	21
	Preparing the Enclosures for Installation	21
	Relay Output Specifications	22
	Phone Line Connection Possibilities	23
	Mounting the Enclosures	25
	Installing and Connecting the Battery in the Battery Enclosure	26
	Connecting the Siren	26
	Connecting the Power Supply to a Power Source	26
	Connecting the Battery to the Main Enclosure	27
	Connecting the Battery Temperature Sensor	28
	Connecting a Sensor	28
	Connecting an External Microphone	29
	Connecting a Module to the Serial Bus Interface	29
Chapter 4	Basic Operations	31
	Acknowledging an Alert On-site or on the Phone	31
	Arming and Disarming Intruder Zones	31
	Bypassing a Zone	32
	Deleting Groups of Information	32
	Filtering Zones on the Main Page	32
	Logging In	32
	Selecting the Language Displayed on the User Interface	33
	Selecting the Temperature Scale	33
	Setting the Date and Time Parameters	33
	Switching Into Edit Mode	33
	Viewing Alert History	33
	Viewing System Diagnostics	33
Chapter 5	Information Creation and Management	35
	Access Levels	35
	Assigning a Contact an Access Level	35
	Creating and Managing Contacts	36
	Creating and Managing Contact Groups	36
	Creating and Managing Partitions	36
	Creating and Managing Temperature Curves	37
	Managing Software Versions	37
	Managing the Power Source	37
	Viewing the History of Contact Actions	37
Chapter 6	System Configuration	39
	Activating the Screen Automatic Scroll on the Main Page	39
	Adjusting the Backlight Settings	39
	Arming and Disarming Your Premises Automatically	39
	Configuring and Managing Modules	40

Table of Contents

	Configuring and Monitoring Ethernet Data	40
	Configuring Phone Settings for the Call Out Sequence	41
	Configuring Programmable Outputs	41
	Configuring Remote Listening.....	42
	Configuring Technical Phone Line Settings	42
	Recording the System Name	42
	Setting the System Trouble Recognition and Recovery Times	43
	Viewing and Resetting Output Circuits.....	43
Chapter 7	Zone Configuration.....	45
	Zone Types.....	45
	Zone Configuration Settings	45
Chapter 8	Configuring a Temperature Zone	47
	Naming the Zone with a Text Label.....	47
	Selecting a Partition.....	47
	Selecting a Module	48
	Selecting an Input.....	48
	Selecting a Zone Type	48
	Setting the Alert Recognition Time	49
	Setting the Alert Recovery Time.....	49
	Activating the Temperature Curve	50
	Setting the High and Low Temperature Thresholds.....	51
	Setting the Critical Temperature Threshold	51
	Setting the Outdoor Temperature Compensation	52
	How it Works: Outdoor Temperature Compensation	52
	Activating a device in the Event of an Alert or Trouble.....	53
	Receiving a Phone Call When an Alert is Active	54
	Receiving an E-mail When an Alert is Active	54
	Enabling the Siren	54
	Enabling the Internal Speaker.....	55
	Recording the Zone Audio Label.....	55
	Resetting the Daily Minimum and Maximum.....	55
	Calibrating the Temperature Probe.....	56
Chapter 9	Configuring a 0-5 Volt Zone Type	57
	Naming the Zone with a Text Label.....	57
	Selecting a Partition.....	57
	Selecting a Module	58
	Selecting an Input.....	58
	Selecting a Zone Type	58
	Resetting the Daily Minimum and Maximum.....	59
	Setting the Alert Recognition Time	59
	Setting the Alert Recovery Time.....	59
	Selecting the Unit of Measure	60
	Entering the Minimum and Maximum Values for an Input	60
	Activating a device in the Event of an Alert or Trouble	60
	Receiving a Phone Call When an Alert is Active	61
	Receiving an E-mail When an Alert is Active	61
	Enabling the Siren	61
	Enabling the Internal Speaker.....	62
	Recording the Zone Audio Label.....	62
	Viewing Zone Calibration	62
	Calibrating the Sensor Outputs.....	62
	Setting the Calibration Zero and Calibration Span	63
	How it Works: Calibration Zero and Calibration Span	63
Chapter 10	Configuring a 4 - 20mA Zone Type	67
	Naming the Zone with a Text Label.....	67

	Selecting a Partition.....	67
	Selecting a Module.....	68
	Selecting an Input.....	68
	Selecting a Zone Type.....	68
	Setting the Alert Recognition Time.....	69
	Setting the Alert Recovery Time.....	69
	Resetting the Daily Minimum and Maximum.....	70
	Selecting the Unit of Measure.....	70
	Entering the Minimum and Maximum Values for an Input.....	70
	Activating a device in the Event of an Alert or Trouble.....	71
	Receiving a Phone Call When an Alert is Active.....	71
	Receiving an E-mail When an Alert is Active.....	71
	Enabling the Siren.....	71
	Enabling the Internal Speaker.....	72
	Recording the Zone Audio Label.....	72
	Calibrating the Sensor Outputs.....	72
	Setting the Calibration Zero and Calibration Span.....	73
	How it Works: Calibration Zero and Calibration Span.....	73
	Viewing Zone Calibration.....	74
Chapter 11	Configuring a Dry Contact Zone.....	75
	Naming the Zone with a Text Label.....	75
	Selecting a Partition.....	75
	Selecting a Module.....	76
	Selecting an Input.....	76
	Selecting a Zone Type.....	76
	Setting the Alert Recognition Time.....	77
	Setting the Alert Recovery Time.....	77
	Resetting the Daily Minimum and Maximum.....	78
	Choosing the Type of End of Line Resistor.....	78
	Selecting the Type of Contact in the Dry Contact Zone.....	78
	Activating a device in the Event of an Alert or Trouble.....	79
	Receiving a Phone Call When an Alert is Active.....	79
	Receiving an E-mail When an Alert is Active.....	79
	Enabling the Siren.....	79
	Enabling the Internal Speaker.....	80
	Recording the Zone Audio Label.....	80
	Viewing Zone Calibration.....	80
	Calibrating the Zone Trouble Thresholds.....	81
Chapter 12	Configuring an Intrusion Zone.....	83
	Naming the Zone with a Text Label.....	83
	Selecting a Module.....	83
	Selecting an Input.....	84
	Selecting a Zone Type.....	84
	Choosing the Type of End of Line Resistor.....	84
	Selecting the Type of Contact in the Dry Contact Zone.....	84
	Providing Enough Time to Disarm After Entry.....	84
	Providing Enough Time to Exit After Arming.....	85
	Activating the at Home Arming.....	85
	Activating the Chime on an Intrusion Zone Type.....	85
	Activating a device in the Event of an Alert or Trouble.....	85
	Receiving a Phone Call When an Alert is Active.....	85
	Receiving an E-mail When an Alert is Active.....	86
	Enabling the Siren.....	86
	Enabling the Internal Speaker.....	86
	Recording the Zone Audio Label.....	87
	Viewing Zone Calibration.....	87

Table of Contents

Chapter 13	Maintenance	89
	Inspecting and Cleaning the Controller	89
	Replacement Fuse Specifications	89
	Replacing a Fuse	90
	Replacing the Battery	90
Chapter 14	Tests	91
	Testing the System	91
	Testing Communication With the Contacts	91
Chapter 15	Troubleshooting	93
Appendix A	List of Terminals in the Main Enclosure and Battery Enclosure	97
Appendix B	Battery Wire Specifications	99
Appendix C	Low Voltage Cable Specifications	101
Appendix D	Technical Specifications	103
Appendix E	Replacement Fuse Specifications	105
Appendix F	Wiring Diagram with Terminals	107
Appendix G	Safety Characteristics and Certification	111
	Index	113
	GSI Group, LLC Limited Warranty	119

1 General Overview

Topics Covered in this Chapter

-
- System Overview
- What to Look for When you Receive Your System
- Terms of Use
- Telecommunication Information
- General Safety Precautions and Usage

Manufacturer

GSI Electronics

5200 Armand Frappier

Saint-Hubert, Qc

Canada

J3Z 1G5



Warranty is void if this product is used in a manner not specified by the manufacturer. Every effort has been made to ensure that his manual is complete, accurate and up to date. The information contained in this manual is subject to change without notice.

System Overview

The Agri-Alert system is a complete alert detection and management system for agricultural applications. It can handle up to 128 alarm inputs spread over several buildings.

Main Unit	Main controller with touchscreen, 8 basic zones, two relays and one microphone. The main system also has a phone card installed to call out.
TP-800	Remote expansion module that allows the addition of eight zones and a programmable output to the system
KP-400	Remote keypad displaying data from the main system with four dry contacts used for intrusion or temperature zones and one programmable output
KPB-400	Tightly sealed keypad displaying the main system's data remotely
WM3000	One-way wireless transmitter and receiver equipped with a dry contact
Wireless module	Module allowing wireless communication between the main alert system and its modules

What to Look for When you Receive Your System

Inspecting your system and making sure you have received all parts helps avoid many hassles.

Shipment contents

- one main unit
- one battery box
- one phone card (installed in main unit)
- one lead-acid battery
- one user manual and one installation manual

Damage inspection

Your system and its components were carefully inspected both electrically and mechanically before shipment. After unpacking all items, check for any obvious signs of physical damage that may have occurred during transit. Report any damage to the shipping agent immediately. Save the original box for possible future shipment.

Returning the unit for repair

If you must return the system for repair, carefully package the system in its original box or an equivalent, and follow these instructions:

1. Call the customer service department to get a Return Material Authorization (RMA) number. Have on hand the system's serial number and date code found on the system's main board.
2. Indicate clearly that the box is to be given to the repair department and attach a copy of the RMA number on the shipping label.
3. Complete and include the Service Form located at the back of this manual.

Contact information

If you experience trouble with your system, or to get repair or warranty information, please contact GSI Electronics Inc. at 1-877-926-2777 or by e-mail at mtl_techsupport@gsiag.com.

Terms of Use

Read and follow all installation, operation, and maintenance information carefully before using the product. Refer to the user documentation for complete product specifications. If the product is used in a manner not specified, the protection provided by the product warranty will be void.

Using the product according to your function

A responsible body is an individual or group responsible for the use and maintenance of equipment, for ensuring that the equipment is operated within its specifications and operating limits, and for ensuring that operators are adequately trained.

Operators use the product for its intended function.

Maintenance personnel perform routine procedures on the product to keep it operating properly

Service personnel are trained to work on live circuits, perform safe installations, and repair products. Only properly trained service personnel may perform installation and service procedures.

General safety usage

Follow the guidelines given below for safe usage of the product:

- Installation must only be performed by qualified service personnel
- Comply with local and national safety codes
- Repairs must only be performed by qualified service personnel
- When replacing the fuses, use only the same type and same rating as specified
- Make sure the unit is disconnected from AC power and from the battery
- Do not try to operate the system if it is damaged. Disconnect the power from the unit and call your local service representative
- Do not operate while condensation is present
- Use of the system in a manner not specified by these instructions may impair the safety protection provided by the system. Do not operate the system outside its rated supply voltages or environmental range
- Failure to read the installation and user manuals or to comply with the warnings and references contained herein can result in serious bodily injury or controller damage
- Do not insert metal objects into the connectors
- Use the system only as specified, or the protection supplied by the product can be compromised
- Carefully read all instructions
- Do not use the system if it does not operate correctly
- The enclosures must be closed and locked before you operate the product
- Use only specified replacement parts

Telecommunication Information

Industry Canada information

This product meets the applicable Industry Canada technical specifications. / Le présent matériel est conforme aux spécifications techniques applicables d'Industrie Canada.

The Ringer Equivalence Number (REN) is an indication of the maximum number of devices allowed to be connected to a telephone interface. The termination of an interface may consist of any combination of devices subject only to the requirement that the sum of the RENs of all the devices not exceed five. / L'indice d'équivalence de la sonnerie (IES) sert à indiquer le nombre maximal de terminaux qui peuvent être raccordés à une interface téléphonique. La terminaison d'une interface peut consister en une combinaison quelconque de dispositifs, à la seule condition que la somme d'indices d'équivalence de la sonnerie de tous les dispositifs n'excède pas cinq.

This product has a Ringer Equivalence Number of 0.1. Ce produit a un indice d'équivalence de la sonnerie de 0.1.

IC number: IC:11880A-PCB402RP002

FCC compliance statements

This equipment complies with Part 68 of the FCC rules and the requirements adopted by the ACTA. On this equipment (phone card, model : PCB402 (300-00319)) inside the AA128 Touch enclosure is a label that contains, among other information, a product identifier in the format US:AAAEQ##TXXXX. If requested, this number must be provided to the telephone company.

ACTA number: US:32ZCN01BGSIE0001 REN: 0.1B

It is designed to be connected to a compatible modular (USOC Jack Type : RJ11) jack that is also compliant. See installation instructions for details.

A plug and jack used to connect this equipment to the premises wiring and telephone network must comply with the applicable FCC Part 68 rules and requirements adopted by the ACTA. A compliant telephone cord and modular plug is not provided with this product. It is designed to be connected to a compatible modular jack that is also compliant. See installation instructions for details.

The REN is used to determine the number of devices that may be connected to a telephone line. Excessive RENs on a telephone line may result in the devices not ringing in response to an incoming call. In most but not all areas, the sum of RENs should not exceed five (5.0). To be certain of the number of devices that may be connected to a line, as determined by the total RENs, contact the local telephone company. For products approved after July 23, 2001, the REN for this product is part of the product identifier that has the format US:AAAEQ##TXXXX. The digits represented by ## are the REN without a decimal point (e.g., 01B is a REN of 0.1B). For earlier products, the REN is separately shown on the label.

If this equipment (phone card, model : PCB402 (300-00319)) causes harm to the telephone network, the telephone company will notify you in advance that temporary discontinuance of service may be required. But if advance notice isn't practical, the telephone company will notify the customer as soon as possible. Also, you will be advised of your right to file a complaint with the FCC if you believe it is necessary.

The telephone company may make changes in its facilities, equipment, operations or procedures that could affect the operation of the equipment. If this happens the telephone company will provide advance notice in order for you to make necessary modifications to maintain uninterrupted service.

If trouble is experienced with this equipment (phone card, model : PCB402 (300-00319)), for repair or warranty information, please contact GSI Electronics Inc. at 1-877-926-2777. If the equipment is causing harm to the telephone network, the telephone company may request that you disconnect the equipment until the problem is resolved. This product is not intended to be repaired. A troubleshooting guide is available in the troubleshooting section of this manual.

Connection to party line service is subject to state tariffs. Contact the state public utility commission, public service commission or corporation commission for information.

If your barn has specially wired alarm equipment connected to the telephone line, ensure the installation of the AA128 Touch through the phone card, model : PCB402 (300-00319), does not disable your alarm equipment. If you have questions about what will disable alarm equipment, consult your telephone company or a qualified installer.

OEM devices

The phone card, model : PCB402 (300-00319) is intended to use only with the AA128 Touch.



Do not use the phone card model PCB402 (300-00319) with any products other than GSI Electronics Inc. products.

Automatic Dialers

Proceed as follows when programming emergency numbers and making test calls to emergency numbers:

- Remain on the line and briefly explain the reason for the call to the dispatcher.
- Program emergency numbers and make test calls in the early morning or late evenings not to interfere in times where the volume of calls is higher.

Electrical safety advisory

Parties responsible for equipment requiring AC power should consider including an advisory notice in their customer information suggesting the customer use a surge arrester. Telephone companies report that electrical surges, typically lightning transients, are very destructive to customer terminal equipment connected to AC power sources. This has been identified as a major nationwide problem.

Alarm dialing equipment

Notice for Equipment Utilizing A Functionally Equivalent Arrangement to Provide Line Seize Capability



Verification of Line Seize capability should be made immediately after installation, and periodically thereafter, in order to ensure that this equipment can initiate a call even when the telephone is connected to the same line is in use.



To ensure proper operation, this equipment must be installed according to the enclosed installation instructions. To verify that the equipment is operating properly and can successfully report an alarm, this equipment must be tested immediately after installation, and periodically thereafter, according to the enclosed test instructions.







Notice for Equipment with Line Seize Capability using an RJ31X or RJ38X Jack



In order for "alarm dialing equipment" to be able to seize the phone line to report an alarm or other event when other customer equipment (telephone, answering system, computer modem, etc.) connected to the same line is in use, "alarm dialing equipment" must be connected to a properly installed RJ31X jack. The RJ31X jack must be connected in series with, and ahead of, all other equipment attached to the same phone line. If you have any questions concerning these instructions, you should consult your telephone company or a qualified installer about installing the necessary jack and alarm dialing equipment for you.

General Safety Precautions and Usage

Safety symbols

	Warning. Read the following text carefully; it contains important information which, if ignored, may cause the controller to operate improperly
	High Voltage. Hazard of electrical shock. Read the message and follow the instructions carefully
	Direct current (DC)
	Alternating current (AC)
	Protective Earth Ground Terminal, Primarily used for protective earth terminals. Terminal connected to conductive parts of a device for the purpose of safety and is intended to be connected to an external system for protective grounding
	Functional Ground Terminal Primarily used for functional earth terminals which are generally associated with test and measurement circuits. These terminals are not for safety earthing purposes but provide an earth reference point.

Safety messages



Turn off the main electrical disconnect switch prior to servicing any of the system modules. Failure to do so might lead to serious injury or death.

Always use extreme caution when measuring voltage or performing procedures that require a module to be powered on.

IMPORTANT: Ensure all your settings are properly configured. Improper configuration of your settings may generate false alerts or fail to generate an alert.

Electrostatic discharge prevention

Electrostatic discharge (ESD) can damage equipment and impair electrical circuitry. ESD damage occurs when electronic components are improperly handled and can result in complete or intermittent failures.

Always follow ESD-prevention procedures when you remove and replace components. Ensure that the chassis is electrically connected to earth ground. Wear an ESD-preventive wrist strap, ensuring that it makes good skin contact. Connect the grounding clip to an unpainted surface of the chassis frame to safely ground unwanted ESD voltages. To guard against ESD damage and shocks, the wrist strap and cord must operate properly. If no wrist strap is available, ground yourself by touching the metal part of the chassis.

For safety, periodically check the resistance value of the antistatic strap, which should be between 1 and 10 megohm (Mohm).

Information for the safe use of the battery

Follow these guidelines concerning the battery:

- Do not store the sealed lead acid battery near heat or fire
- Do not store in sunlight
- Only remove the sealed lead acid battery from the equipment when not in use
- Fully charge the sealed lead acid battery before storing it for an extended period
- After extended periods of storage, it may be necessary to charge and discharge the sealed lead acid battery several times to obtain maximum performance
- Keep the sealed lead acid battery out of the reach of children and animals
- Seek medical advise if a battery or part of it has been swallowed

The batteries are supplied by B&B Battery. The models are BC7-12 and BP7-12. These batteries are certified and complied to these standards :

- UL1989
- IEC 61056
- JIS C8702
- GB/T 19639

Safely disposing of the battery

NOTICE

Do not dispose of the battery as unsorted municipal waste.



Go to B&B Battery's website for recycling information. Dispose in discharged condition and cover the battery terminals with an isolation tape.

You may ship your sealed lead acid batteries to B&B Battery, freight prepaid (you pay the freight). B&B Battery will gladly recycle the sealed lead acid batteries for you. Call our customer service prior to shipping your batteries to us: 1-323-278-1900 (North America and South America) or email us at sales@bbbattery.com for details and further arrangement for your recycling needs.

NOTES

2 Getting Started

Topics Covered in this Chapter

- Special Tools Needed for Installation
- Guidelines on the Ideal Location for Installation
- Correctly Supporting and Routing Cables
- Grounding the System

Special Tools Needed for Installation

The following tools are needed for the installation of your system:

- Hammer and punch to remove the knockouts at the bottom of the enclosures.
- Silicone caulking to seal the module mounting screws.

Guidelines on the Ideal Location for Installation

Consider the environment, mounting recommendations, and clearance space to choose the ideal location for your system.

Operating Environment

- To avoid exposing the system to harmful gases or excessive humidity, install the system modules in a corridor or a room dedicated to electronic controllers.
- The ideal ambient temperature is between 20 °C and 25 °C (68 °F - 77 °F). The temperature should not go lower than 0 °C (32 °F) and should not exceed 40 °C (104 °F).
- Ensure there is sufficient ventilation around the unit.
- Install the modules far from sources of vibrations and where it is not likely to get bumped.

IMPORTANT: *If you are not planning on installing the system immediately, store the modules in a cool dry place.*

Requirements for the Mounting Structure

Mount the system into the supporting structure behind a drywall. If this is not possible, install pieces of wood that can be screwed into the back structure and install the units on the pieces of wood.

Clearance Around the System Modules

The following minimum clearances must be respected around both the main system and the battery enclosure.

- 305 mm (12 inches) above the modules to allow opening of the cover.
- 305 mm (12 inches) below the modules to leave room for the wiring.
- 305 mm (12 inches) between the modules to avoid electromagnetic interference.

Chapter 2: Getting Started

- 305 mm (12 inches) between any module and a breaker box to avoid electromagnetic interference.
- 610 mm (24 inches) between any module and a variable frequency drive to avoid electromagnetic interference.

Figure 2-1 Required minimum clearance around the system modules

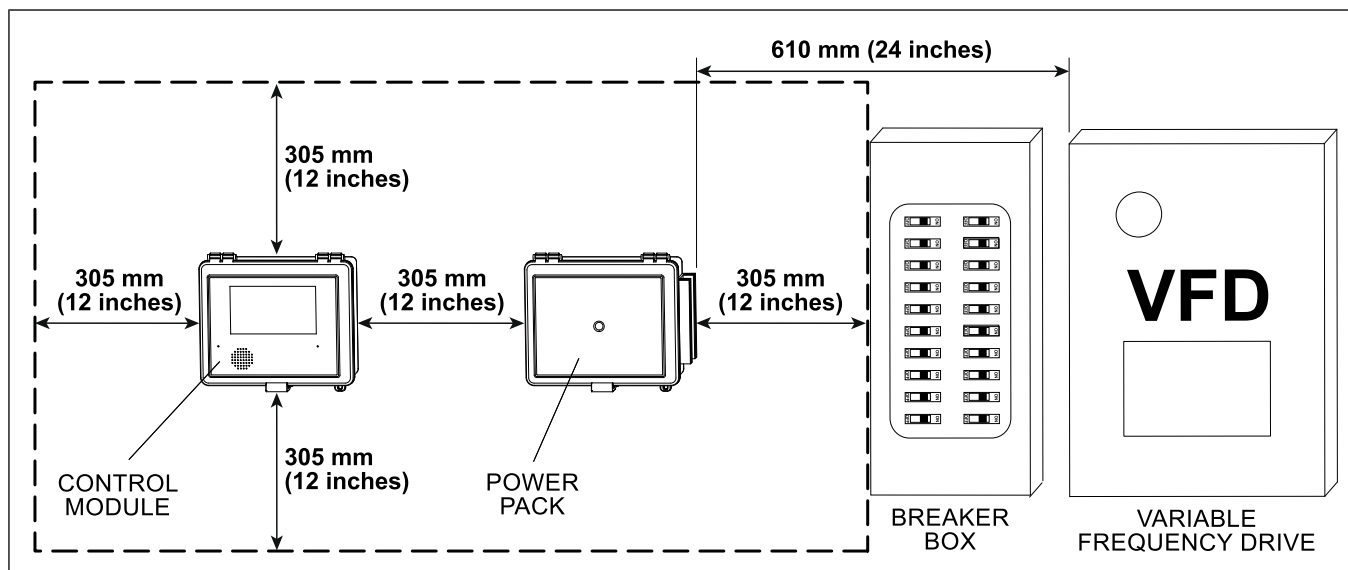

Correctly Supporting and Routing Cables

Properly supporting and routing the cables helps avoid electromagnetic interferences and wire damages.

Cable Support

Support the cables with clips or cable trays whenever possible to avoid damage at the connection points.

Cable Routing

When low voltage cables run parallel to high voltage cables (120/230/380 VAC or 24 VDC), place them at a distance of at least 300 mm (12 inches) from each other to avoid electromagnetic interference. See following figure.

If low voltage cables cross high voltage cables, ensure they cross at an angle of 90° to minimize electromagnetic interference.



Do not install rigid conduits. Only nylon cable glands are permitted for cable or wire fastening.



Always use watertight compression glands to seal cable entries into the controller. Do not use metallic cable-holders.



Use watertight compression cable glands rated IP51 for each cable used.



Use silicone to seal the cable gland rated IP51 if more than one cable is use in the same cable gland.



If the product enclosures are not sealed correctly and the installation does not respect the manufacturer recommendations, the warranty is void.



Ensure all cables enter through the bottom of the controller. Do not make holes on the top or on the sides of the enclosures. Be careful not to damage the electronic cards located inside the enclosure when drilling or punching the knockouts at the bottom of the enclosure.

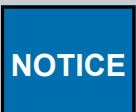

It is acceptable to use cables in a flexible tube fastened by cable glands at the end of the flexible tube.

Figure 2-2 Distance between low and high voltage cables

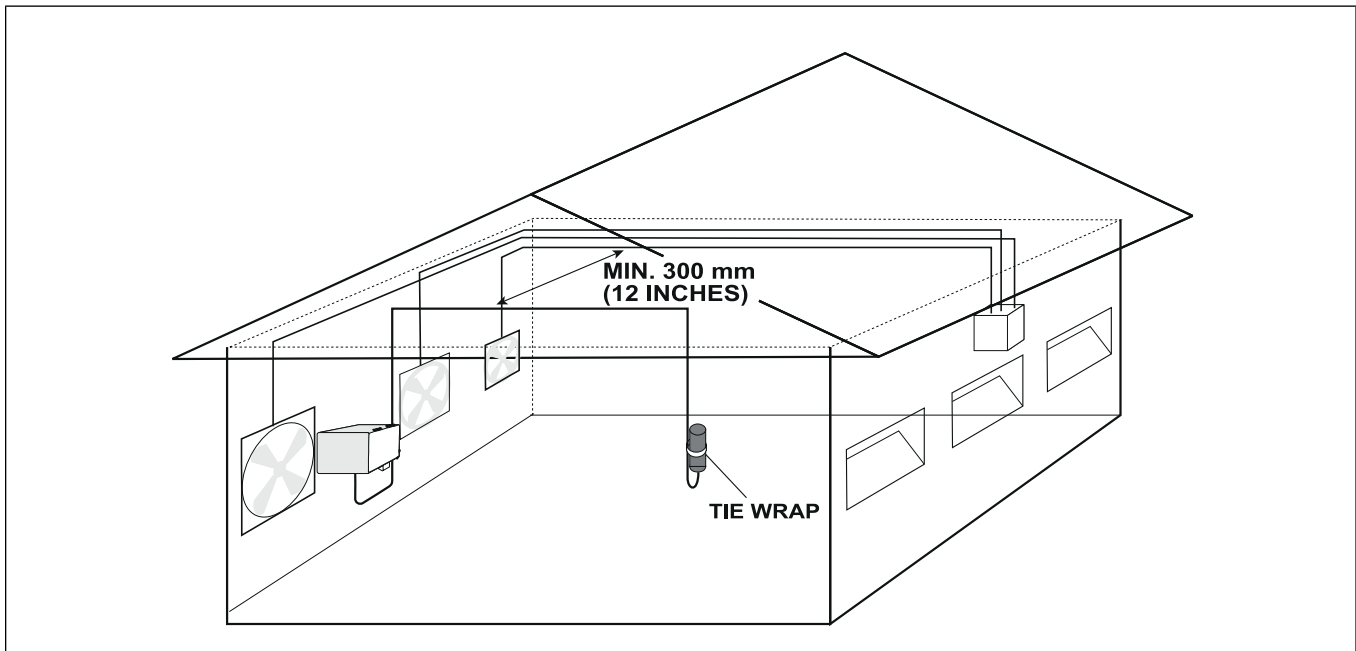

Grounding the System

A correctly grounded system protects your equipment from electrical surges and spikes.



Each module must have its own ground connection from a common junction box. Do not run the earth ground cable between the modules.

NOTICE

The ground resistance levels must comply with local and national electrical codes.

IMPORTANT: If outdoor connections are used, mount the enclosure as close as possible to the entry point of the outdoor wiring.

IMPORTANT: An improper ground connection voids the system's warranty.

Insert the rod into the ground until a few inches of the tip is left above ground level. Attach the cable to the rod tip with an appropriate connector. Attach the other end of the cable to a breaker box or a junction box near the main enclosure.

Figure 2-3 Grounding installation depending on bedrock depth

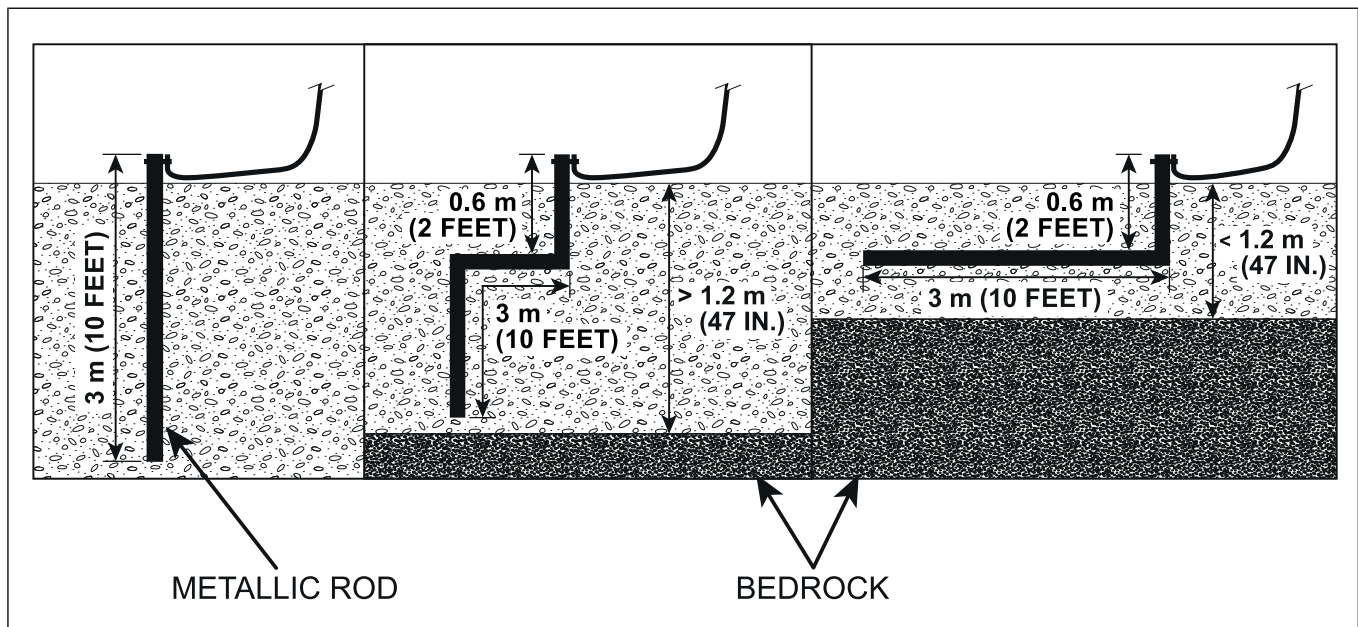

- If the bedrock is more than 3 meters (10 feet) below ground level, drive the grounding rod vertically 3 meters (10 feet) into the ground.
- If the bedrock is more than 1.2 meters (47 inches) below ground level, drive the rod into the ground to bedrock level and bury the remainder horizontally at least 0.6 meters (2 feet) below ground level.
- If the bedrock is less than 1.2 meters (47 inches) deep, bury the rod horizontally at least 0.6 meters (2 feet) below ground level.

NOTE: Refer to your local regulations and practices if an adequate grounding installation isn't possible.

Rod Specifications for Grounding

The rod specifications are guidelines only. Refer to your national and local regulations for compliance criteria.

Table 2-1 *Grounding rod specifications*

Item	Description
Material	Metallic, normally steel core.
Rod surface	The surface must be clean. It cannot be coated with paint, varnish or any non-conducting substance.
Minimum diameter	16 mm (5/8 inches)
Minimum length	2440 mm (8 feet)

Cable Specifications for Grounding

The cable specifications are guidelines only. Refer to your national and local regulations for compliance criteria.

Table 2-2 *Grounding cable specifications*

Item	Description
Certification and type	CSA, TEW type.
	UL, 1015 type, 12 AWG, 600 V, 105 °C (221 °F), green/yellow insulated wire.
Maximum length	15 meters (50 feet)
Suggested cable	Beldon # 9912, color code 189, or equivalent

NOTES

3 Basic Connections

Topics Covered in this Chapter

- Preparing the Enclosures for Installation
- Relay Output Specifications
- Phone Line Connection Possibilities
- Mounting the Enclosures
- Installing and Connecting the Battery in the Battery Enclosure
- Connecting the Siren
- Connecting the Power Supply to a Power Source
- Connecting the Battery to the Main Enclosure
- Connecting the Battery Temperature Sensor
- Connecting a Sensor
- Connecting an External Microphone
- Connecting a Module to the Serial Bus Interface

Preparing the Enclosures for Installation

Preparing the equipment before mounting it to the wall facilitates manipulation and ensures all parts are ready to be installed.

Before You Begin

You need a 10 AWG gauge wire to connect the main enclosure to the battery enclosure for the battery supply. You also need a twisted pair wire and shielded wire with a minimum gauge of 20 AWG for the battery temperature sensor in the battery enclosure. The wires must be less than 36 inches long.

1. Close both the main enclosure and the battery enclosure.

NOTICE

Perforating the punch holes while the enclosures are open may crack the enclosure.

2. Using a hole punch tool, perforate the punch holes needed for your installation at the bottom of each enclosure.
3. Drill a hole the size of the your cable glands on the bottom right hand side of the main enclosure
4. Using the latches at the bottom of each enclosure, open them and remove the punched out fragments.
5. Install the cable glands provided with your system to the bottom of each enclosure.
6. Close the main enclosure and the battery enclosure.

Chapter 3: Basic Connections

7. Fasten the two metal brackets on the mounting holes located behind the main enclosure using four screws.
8. Using the specifications given below as a guide, drill holes into the area where the enclosures will be mounted.

IMPORTANT: Leave a clearance of at least 16 inches at the top of the enclosures to allow the cover to be removed for maintenance.

Remember

If the enclosures can't be mounted to the supporting structure behind the drywall, mount the enclosures onto a wooden or metal frame. Do not mount the enclosures directly onto the drywall.

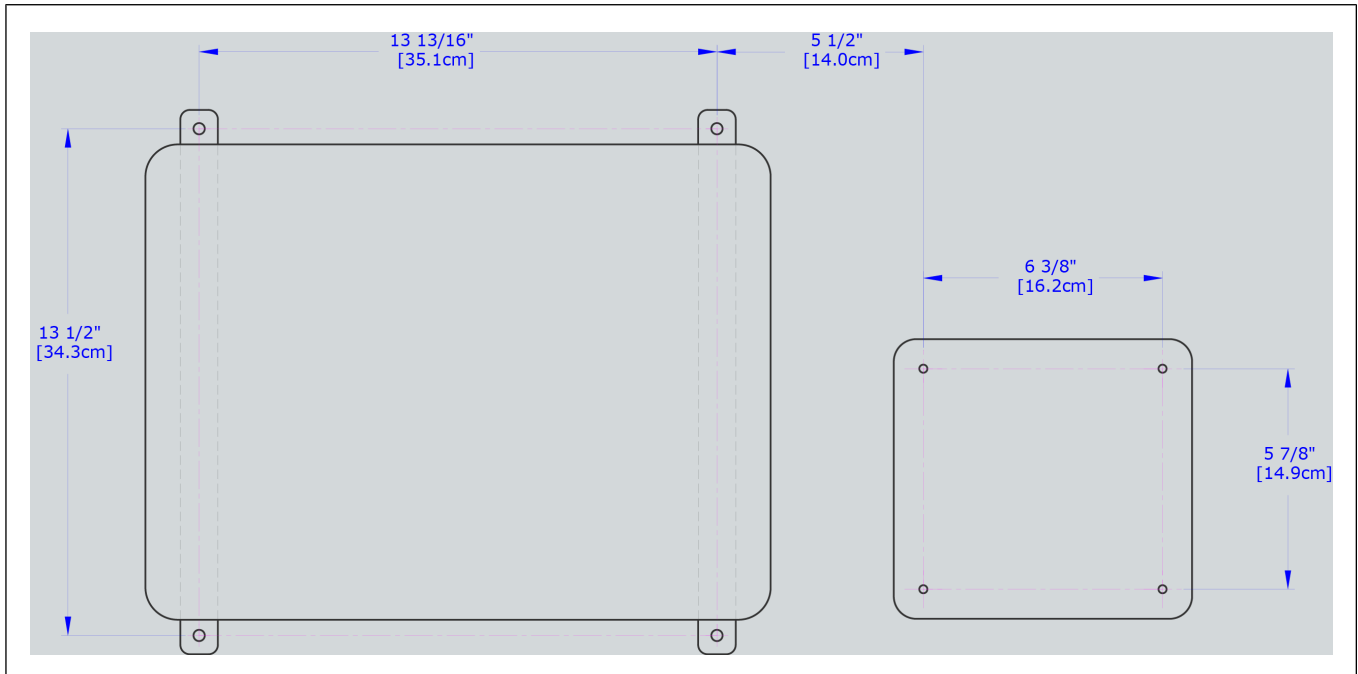

Relay Output Specifications

The maximum voltage on the relay outputs is 28 VDC with a maximum current of 4A.

The minimum permissible load on the relay outputs is 0,1A.

NOTE: DC supply have the possibility of two different supply outputs : 12Vdc output and the 28 Vdc output.

The maximum voltage supplied to the 12 Vdc output is 12 VDC with a maximum current of 750 mA.

The maximum voltage supplied to the 28 Vdc output is 28 VDC with a maximum current of 350 mA.

Phone Line Connection Possibilities

The system uses the telephone line to reach you when an alert is set off. There are two types of phone line connections depending on your needs.



To reduce the risk of fire, use only No. 26AWG or larger telecommunication line cord



Supply the AA-128 Touch under 120Vac to use the phone card circuit



Unplug the phone cord while installing or servicing the phone card

Customer Phone Priority Connection

A customer phone priority connection is made through a regular phone outlet. With this type of connection, the system waits until the phone line is free before beginning the dial out sequence..



This type of connection is not recommended. The inability for the system to make phone calls during an alert may cause the loss of livestock and property.

The following is required to make such a connection.

- A regular phone cable with an RJ11 connector.
- A standard phone wall jack near the control module.

Only two wires will be used to connect the control module to the phone line.

Figure 3-1 Example of a phone line hookup without line seizure

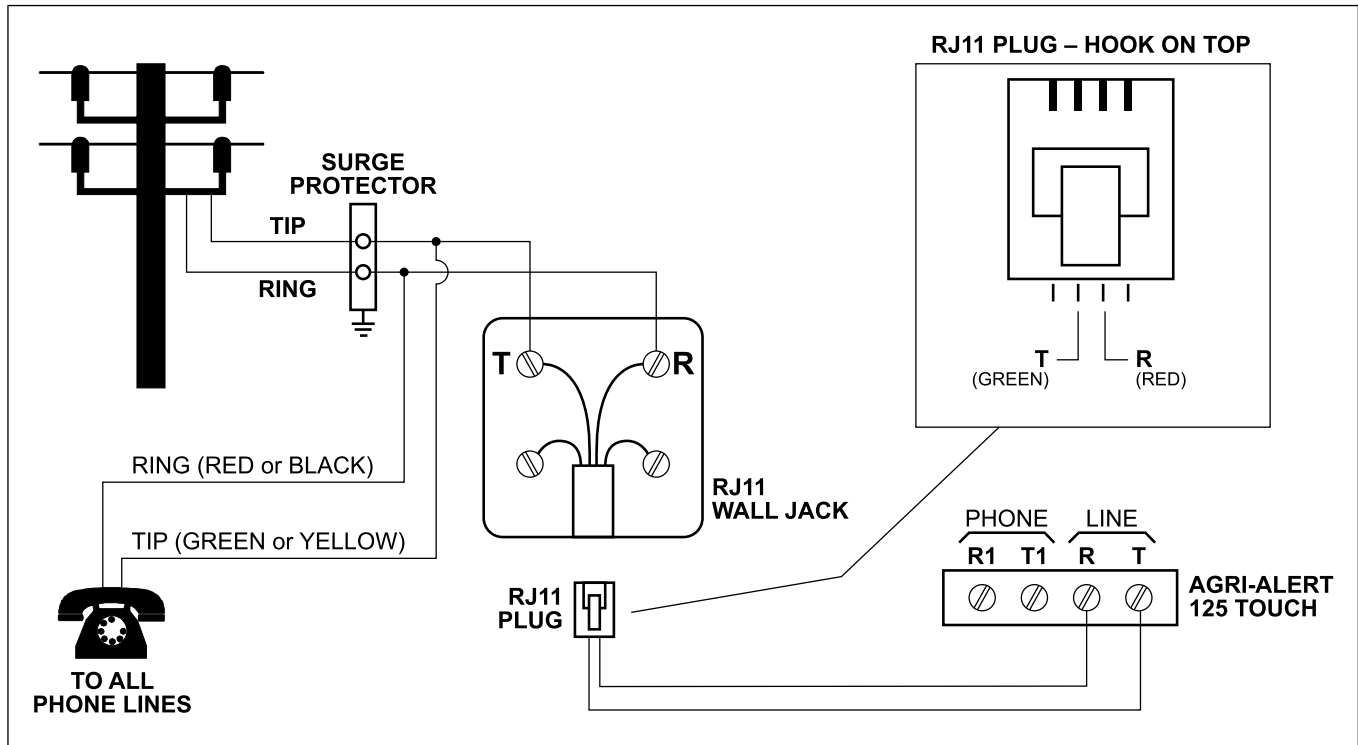

System Phone Priority Connection (Line Seizure)

A system phone priority connection is made at the phone line entrance bridge (where the phone company line comes in). With this type of connection, the system seizes the phone line if a call is in progress in order to send alerts. This is the recommended type of phone connection.



In order for dialing equipment to be able to seize the phone line to report an alert or other event when other customer equipment (telephone, answering system, computer modem, etc.) is connected to the same line in use, the dialing equipment must be connected to a properly installed RJ31X jack. The RJ31X jack must be connected in series with, and ahead of, all other equipment attached to the same phone line. Series installation of an RJ31X jack is depicted in the following figure. If you have any questions concerning these instructions, you should consult your telephone company or a qualified installer about installing the necessary jack and alarm dialing equipment for you.

NOTE: Install the system as close as possible to the phone line entrance bridge to facilitate the installation.

The following is required to make such a connection.

- An RJ31 cable (8 wires) and connector. A standard 4-wire phone cable can also be used if the wires are properly connected to an RJ31 connector.
- An RJ31 alarm interface jack.

Four wires are used to connect the control module to the phone line.

Refer to the local building code and telephone regulations to determine the type and quality of cable required.

Figure 3-2 Example of a phone line seizure hookup

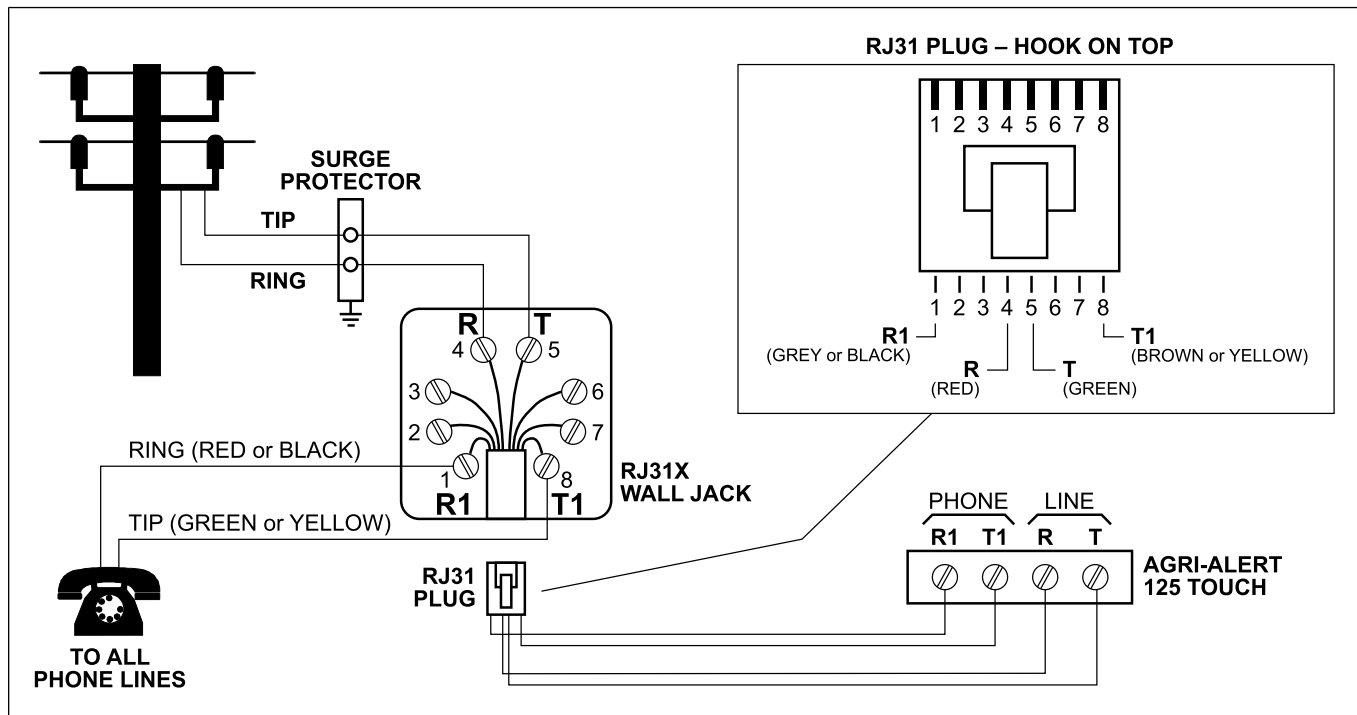

Mounting the Enclosures

Securely mounting the enclosures to the wall in the ideal location allows for an optimal use of the system when navigating the menus.

Before You Begin

NOTICE

When using outdoor connections, mount the enclosure as close as possible to the entry point of the wiring.

IMPORTANT: *The enclosures must be mounted near an unswitched AC power outlet and a telephone plug.*

IMPORTANT: *Mount the system into a wooden or metal frame. Do not mount the system directly into the drywall*

1. Using four of the eight 4.76 millimeters (0.1875 inch) screws, secure the main enclosure to the metal or wooden frame on the wall.
2. Open the battery enclosure and remove the black screw caps covering the mounting holes of the battery enclosure.
3. Using the four remaining 4.76 millimeters (0.1875 inch) screws, secure the battery enclosure 114 millimeters (4.5 inch) away from the main enclosure.
4. Place the previously removed black screw caps on the screws used to mount the battery enclosure to make the enclosure water tight. Add silicone caulking to completely seal the screws.
5. Verify that both enclosures open easily by pulling on the latch, or lock by pushing on the latch at the bottom of the enclosures.

Chapter 3: Basic Connections

NOTE: Leave a clearance of at least 16 inches at the top of the enclosures to allow the cover to be removed for maintenance.

6. Ensure the ventilation openings on the sides of the enclosures are not obstructed.

Installing and Connecting the Battery in the Battery Enclosure

1. Put battery terminals toward the top.
2. Align both Velcros in the Battery Box and then press on the battery to fasten it to the battery enclosure.
3. Install the black wire (from printed circuit board J4) to the negative battery terminal.
4. Install the red wire (from printed circuit board J3) to the positive battery terminal.
5. Close the circuit of the main sector voltage to reactivate the controller.

Connecting the Siren

The siren is used as a visual and audio queue when an alert is active. The use of a siren is optional.

Before You Begin

NOTICE

The maximum voltage supplied to the siren is 12 VDC with a maximum current of 1 ampere.

NOTICE

The siren's audio must not exceed 120 decibels.

NOTICE

The system must be connected to the battery if a siren is used.

1. Connect the wires from the siren to the SIREN terminals on the main board.
Make sure the positive wire is connected to the positive terminal of the siren.
2. If the siren's impedance is too high, add a 1.5 ohm resistor (1/2 watt) in parallel with the siren, as close as possible to the siren on the circuit.
3. If you are not using a siren, connect a 1.5 ohm resistor (1/2 watt) to the siren output or disable the siren monitoring.

Connecting the Power Supply to a Power Source

Once the main enclosure and the battery enclosure are mounted to the wall and connected together, the last step before configuration is to connect the equipment to a power source.

Before You Begin

IMPORTANT: *An external or circuit breaker and a disconnecting switch must be installed to interrupt power to L1 and N/L2 electric power lines before connecting the system's main sector input on the panel mount power supply. It must be in close proximity to the equipment and within easy reach of the operator. It must be marked as the disconnecting device for the equipment. We recommend installing it to the left of the system or to the right of the battery enclosure.*

From the power source, follow the wiring diagram to connect the main sector to the system main sector inputs on the panel mount power supply. We recommend using a DPST disconnecting switch in series with a breaker. In the case of the use of a SPST disconnecting switch, connect SPST disconnecting switch to cut the Hot line with a Neutral circuit case.

IMPORTANT: *Before plugging the system into an electrical supply, power on your system to make sure the backup battery is functioning correctly.*



Disconnect supply before servicing.



Lock the enclosure when wiring is complete or when servicing. Use the nut and bolt included or a padlock (not included) to lock the enclosure.

1. Ensure there is no switch on the power outlet.
2. Plug the wire from the power supply into a power source (AC main sector voltage).
3. Power on the system and make sure it is receiving power from the power source only.

The system works at nominal voltage between 100Vac and 240Vac for the main sector voltage. The working voltage range is between 90Vac and 264Vac. The system consumes a current of 2.90A at the minimum voltage on the main sector voltage input. Size your breaker circuit and the wires according with local and national safety codes. The recommendation current value is 5A for the breaker.

Connecting the Battery to the Main Enclosure

Connecting the battery enclosure to the main enclosure is the step that allows you to power on your system for the first time.

Before You Begin

IMPORTANT: *The Agri-Alert 128 Touch may not power up when you plug the Battery supply the first time without AC supply.*

NOTE: *Finish your installation before connecting the battery to the battery enclosure.*

IMPORTANT: *It is possible that the system doesn't power on without AC supply when the battery is plugged in for the first time.*

What You Should Know

NOTICE

Do not use a different battery than the one supplied with your system. See the appendices for specifications.



Do not use another kind of battery than the lead-acid batteries recommended by GSI Electronics Inc. Although different technologies of lead-acid batteries are available on the market, the use of other technologies can cause the controller to malfunction, increase the risk of explosion, and increase the risk of fire.



Use only the rechargeable type of recommended lead-acid batteries. The non-rechargeable type of battery can cause the controller to malfunction, increases the risk of explosion, and increases the risk of fire.

1. Run a 10 AWG cable of maximum 36 inches, from the battery enclosure to the main system enclosure into cable glands to the bottom of each enclosure.
2. Connect one end of a cable to the negative terminal block VBAT - on the main board in the main enclosure.
3. Connect the other end of the cable to the negative terminal BATTERY - in the battery enclosure.
4. Connect one end of the other cable to the positive terminal block VBAT + on the main board in the main enclosure.
5. Connect the other end of the cable to the positive terminal BATTERY + in the battery enclosure.

Connecting the Battery Temperature Sensor

1. Run a 20 AWG cable of maximum 36 inches from the battery enclosure to the main enclosure.
2. Connect one end of the cable to the negative terminal BAT TEMP - on the main board in the main enclosure.
3. Connect the other end of the cable to the negative terminal TEMP - in the battery enclosure.
4. Connect one end of the other cable to the positive terminal BAT TEMP - on the main board in the main enclosure.
5. Connect the other end of the cable to the positive terminal TEMP + in the battery enclosure.

Connecting a Sensor

A variety of different sensors can be hooked up to the system to monitor various inputs. The terminals used for sensor inputs are numbered Z1, Z2, Z3, etc. on the main board.

What You Should Know

NOTE: *Sensors needing a DC supply have the possibility of two different supply outputs : 12Vdc output and the 28 Vdc output.*

The maximum voltage supplied to the 12 Vdc output is 12 VDC with a maximum current of 750 mA.

The maximum voltage supplied to the 28 Vdc output is 28 VDC with a maximum current of 350 mA.

Connect each sensor to a Z terminal and to the COM terminal.

NOTE: *Each COM terminal is used by two zones. For example, Z1 and Z2 use the same COM.*

IMPORTANT: *Make sure each sensor is connected to the proper COM. False alarms can result if the wires are not properly connected.*

After You Finish

See Low Voltage Cable Specifications and Wiring Diagram with Terminals for additional information on sensors.

Connecting an External Microphone

An external microphone can be hooked up to the system to listen in from a distance if needed.

1. Open the main enclosure.
2. Connect the wire shielding to the terminal marked SHIELD.
3. When connecting an external microphone, connect the SIGNAL and CASE terminals to the microphone.

The auxiliary terminal marked as AUX on the main board is not used.

Connecting a Module to the Serial Bus Interface

The serial bus interface (SBI) enables communication between the main system and the modules.

What You Should Know

The maximum voltage supplied to the output is 28 VDC with a maximum current of two amperes.

1. Locate the SBI wires on the module you want to connect to the main system.
2. Connect the SBI wires from the module to the main board of your system.

IMPORTANT: *Make sure to connect same numbers together.*

NOTES

4 Basic Operations

Topics Covered in this Chapter

- Acknowledging an Alert On-site or on the Phone
- Arming and Disarming Intruder Zones
- Bypassing a Zone
- Deleting Groups of Information
- Filtering Zones on the Main Page
- Logging In
- Selecting the Language Displayed on the User Interface
- Selecting the Temperature Scale
- Setting the Date and Time Parameters
- Switching Into Edit Mode
- Viewing Alert History
- Viewing System Diagnostics

Acknowledging an Alert On-site or on the Phone

As soon as an alert is set off, the screen displays a popup prompting you to acknowledge the alert. If nobody is on site to acknowledge the alert, the dial out sequence begins after the set amount of time. Acknowledging the alarm puts a stop to the notification process and you can take action to get the zone back into a normal condition.

- When on-site, proceed as follows:
 1. Either from a module with a keypad connected to the system or on the system's user interface, enter your password when prompted.
 2. Find the source of the problem and take action to return the zone into a normal state.
- When notified by phone, text, or e-mail, proceed as follows:
 1. Enter your four digit password when asked by the system.
 2. Contact someone on-site or take action to return the zone into a normal state.

NOTE: *If you miss an alert call from the system, you can call the system and follow the instructions to acknowledge the alert.*

Arming and Disarming Intruder Zones

1. From the main screen, click on the drop down menu button.
2. Click on the arm or disarm button.

The intrusion zones that are in a trouble or alert state are displayed. Intrusion zones must be in a normal state to be armed.

3. Enter your four digit pin number using the keypad on the right hand side.

Bypassing a Zone

Bypassing a zone allows you to keep the zone enabled, but not monitored by the system for a period of time. The zone keeps its configuration, but no alerts are set off by the system for bypassed zones.

1. Click on the zone you would like to bypass on the zone monitoring screen (main page).
2. Click on the **Bypass** button .
The zone tile turns yellow and the minimum and maximum thresholds are no longer displayed.
3. To return to monitoring mode, click on the **Bypass** button.
The zone tile turns green and the minimum and maximum thresholds are displayed.

Deleting Groups of Information

Keeping accurate information such as contacts, contact groups, temperature curves and zones ensures no false alerts are generated and the correct people are informed when an alert does occur. When information is no longer valid, you can erase a group of information at the same time.

Before You Begin

IMPORTANT: *The following steps delete the entire displayed page including information in all tabs.*

1. Navigate to the page where you would like to delete the information.
2. Click on the garbage icon .

A message prompting you to confirm you want to delete all information on the page is displayed.

Filtering Zones on the Main Page

You can apply a filter on the main page in order to see zones according to type or status. For example, you can choose to display only zones that are in an alert state or only temperature zones.

1. Click on either the filter showing zone type icons or the filter showing zone status icons at the bottom of the main page.
2. Select the filter to be applied.
3. To show all zones, click on the  icon.

Only the zones fitting the filter criteria are displayed on the main page.

Logging In

When trying to modify certain parameters, the system prompts you to enter either a master or an installer password to have access to modify the parameter.

1. When prompted, click on the login icon .
2. Enter the password requested.

Once you are logged on, the icon changes to .

NOTE: After 10 minutes of inactivity on the touchscreen, you are automatically logged off and must log in again to modify certain parameters.

Selecting the Language Displayed on the User Interface

Selecting the proper language allows you to navigate with confidence through the user interface.

1. Click on the square showing two letters representing a language  on the user interface.
2. Select the language in which you want the information displayed.

Selecting the Temperature Scale

1. Click on **Menu**→**System**→**Settings**→**Time and units** .
2. Select the desired temperature scale next to **T units**.

Setting the Date and Time Parameters

1. Click on **Menu**→**System**→**Settings**→**Time and units** .
2. Set the time and date and choose the desired format for display.

Switching Into Edit Mode

Some information and tabs are available for viewing in status mode, and others are displayed when switching to edit mode.

1. Follow the menu path of your choice.
2. Click on the pencil icon  to change into edit mode.

All tabs containing parameters that can be edited are displayed.

Viewing Alert History

The system records the date, time, alert threshold at the time of the alert, and name of the person that acknowledged the alert for all alerts. The alert history of each zone is displayed individually on the zone page.

1. From the main page, click on the zone you would like to view.
2. Click on the **History** tab.

The complete alert history for the zone is displayed

3. Use the arrows on the right to scroll down if needed.

Viewing System Diagnostics

The diagnostic menu lets you view important information and possibly find a reason for an alert or trouble.

1. Click on **Menu**→**System**→**Diagnostic**.

NOTE: Parameter values in the **Diagnostic** menu are read only.

2. Navigate through all the tabs to verify that all settings are normal.

NOTE: *When a reading is not normal, the box is highlighted in red or orange when a trouble is present.*

5 Information Creation and Management

Topics Covered in this Chapter

- Access Levels
- Assigning a Contact an Access Level
- Creating and Managing Contacts
- Creating and Managing Contact Groups
- Creating and Managing Partitions
- Creating and Managing Temperature Curves
- Managing Software Versions
- Managing the Power Source
- Viewing the History of Contact Actions

Access Levels

Access levels are assigned to contacts. The levels limit the type of actions that can be performed by the contact.

Access Level	Rights with the access level
User	The contact can acknowledge alarms and view system information
Master	The contact can edit certain configuration parameters and parameters for every-day usage
Installer	The contact has full access and can modify any parameter

Assigning a Contact an Access Level

In order for you to control the actions that are performed by your contacts, you can set four different levels of access according to the contact's function on site.

1. Click on **Menu**→**System**→**Contacts**.
2. In edit mode, under the **Security** tab, click on the edit field next to the **Access level** button.
3. Enter the desired access level and enter a password.

Creating and Managing Contacts

Contacting the correct people and using the correct means of communication during an alert can help protect your animals and premises.

1. Click on **Menu**→**System**→**Contacts**.
2. In edit mode, under the **General** tab, enter the contact name and populate the fields
3. Once you complete a contact, use the navigation buttons on the top right to navigate through the existing contacts, to create new contacts, or to delete existing contacts.

Creating and Managing Contact Groups

Creating contact groups allows the correct people to be contacted when an alert is present depending on the type of alert, the time at which it occurs, or even the day of the week on which the alert is set off.

Before You Begin

NOTE: *Contacts must be created before contact groups can be created.*

NOTE: *Contact groups must be created before they can be assigned to a zone.*

1. Click on **Menu**→**System**→**Groups**.
2. In edit mode, under the **General** tab, enter the group name.
3. Click on **Test report** if you would like the group to receive a test report.
4. Enter the information of week day, week night and weekend start times.
5. Complete the **Day**, **Night**, and **Weekend** tabs with the contacts to be alerted during each time period set.
6. Once you complete a contact group, use the navigation buttons on the top right to navigate through the existing contact groups, to create new contact groups, or to delete existing contact groups.

Creating and Managing Partitions

Creating partitions allows you to group zones together and monitor them as a group. The partition can be bypassed as a group or placed in clean mode as a group. Zones in the same partition are usually located in the same building or have a common factor linking them together. Partitions are displayed as a group on the main screen.

1. Click on **Menu**→**System**→**Partition**.
2. Click on the pencil icon  and populate the fields.

NOTE: *The list of zones assigned to the partition are displayed on the right hand side. Zones must be assigned to a partition when configuring a zone for it to be displayed here.*

3. Once you are done creating a partition, navigate using the arrow keys on the top left to create other partitions, modify existing partitions or view existing partitions.

Creating and Managing Temperature Curves

Temperature curves ensure the optimal temperature with relation to the age and maturation of your animals. Setting the correct curve points is beneficial for productivity.

1. Click on **Menu**→**System**→**Curves**.
2. In edit mode, under the **General** tab, populate the fields keeping in mind the correlation between day number and temperature.
3. Once you are done creating the first curve, use the navigation buttons to navigate through existing curves, to create a new curve, or to delete an existing curve.

Tip

Use the **Copy** and **Paste** buttons to create your curves or assign zones to curves rapidly.

After You Finish

When you are done creating your curves and assigning them to zones in edit mode, you can view the zones assigned to a curve by clicking on the **Zone** tab.

Managing Software Versions

Every now and then a new software version is released with updates on features. Making sure the software version is up to date ensures you have access to the latest features.

1. Insert the USB stick into the USB port of the main system.
2. Click on **Menu**→**System**→**Settings**→**Software Info** to view the current software, firmware, and hardware information.
3. Under the **File** tab, click on the **Export** button to export your current data onto a USB stick or select **Import** to import information from the USB stick.
4. Wait for a message indicating the process is complete.

Managing the Power Source

There are different actions that can be set up for the system to manage the amount of power it draws for its power source during certain events.

1. Click on **Menu**→**System**→**Settings**→**Power Settings**.
2. In edit mode, under the **General** tab, select the options for saving power when the power source is the battery.
3. Set the recognition time and the recovery time in the power failure options.

Viewing the History of Contact Actions

To closely monitor the alert and trouble history, the actions, accompanied by dates and times at which they occurred are logged in each contact's history.

1. Click on **Menu**→**System**→**Contacts**.
2. Look under the **History** tab for a list of all actions performed by the contact.
3. Use the arrows to scroll down if need be.

NOTES

6 System Configuration

Topics Covered in this Chapter

- Activating the Screen Automatic Scroll on the Main Page
- Adjusting the Backlight Settings
- Arming and Disarming Your Premises Automatically
- Configuring and Managing Modules
- Configuring and Monitoring Ethernet Data
- Configuring Phone Settings for the Call Out Sequence
- Configuring Programmable Outputs
- Configuring Remote Listening
- Configuring Technical Phone Line Settings
- Recording the System Name
- Setting the System Trouble Recognition and Recovery Times
- Viewing and Resetting Output Circuits

Activating the Screen Automatic Scroll on the Main Page

The screen can scroll automatically at preset intervals to move from one page to the other when the zone tiles are displayed on more than one page on the main page.

What You Should Know

NOTE: *More than one page of zone tiles must be available for the screen to scroll.*

1. Click on **Menu**→**System**→**Settings**→**General settings**.
2. In edit mode, under the **General** tab, check the **Auto scroll zone screen** button.
3. Set the time interval at which the screen scrolls from page to page on the main page.

Adjusting the Backlight Settings

1. Click on **Menu**→**System**→**Settings**→**Status and ID**.
2. In edit mode, under the **General** tab, either select the **Use auto backlight adjust** or enter a backlight percentage next to the **Backlight** button.

Arming and Disarming Your Premises Automatically

The intrusion zones on sites that operate during regular hours and rarely go beyond set times can be configured to arm and disarm automatically at set times during the week and during the weekend.

1. Click on **Menu**→**System**→**Settings**→**Intrusion arming**.
2. Select **Use force arming** if you want the system to automatically arm itself when a zone is in an alert or trouble state.

3. Set the **Auto arming** parameters.
4. Set the **Auto disarm** parameters.

Configuring and Managing Modules

The main system has a total of eight inputs for zones. In order to add up to a total of 128 zones, modules must be hooked up to the system. Once the modules are hooked up, they must be initialized for the system to recognize them and make them available for zone configuration.

1. Click on **Menu**→**System**→**Modules**.
2. In edit mode, under the **General** tab, enter the module name.
3. Choose the module type.
4. Enter the module ID.
5. Under the **Diagnostic** tab, you can view the following statistics:
 - Network errors since last reboot
 - Number of coms in last 5 minutes
 - Number of com errors in last 5 minutes
 - Network error in last 5 minutes
6. To reset the statistics, click on the **Reset Stats** button.

Configuring and Monitoring Ethernet Data

The ethernet settings allow you to choose between a static or dynamic ethernet connection, or just view the ethernet settings. You can also configure the system e-mail to enable the function of the system sending an e-mail in the event of an alert.

Before You Begin

NOTE: *If the ethernet icon is orange, the ethernet connection is bad.*

1. Click on **System**→**Settings**→**Ethernet settings**.
2. In edit mode, under the **General** tab, click on the edit field next to the IP address field to bring up a 2 choice list.
3. Select either a static or a dynamic connection.
4. If you choose a dynamic connection, populate the following parameters:
 - Subnet mask
 - Default gateway
 - DNS 1
 - DNS 2

Configuring Phone Settings for the Call Out Sequence

The call out phone settings are the parameters the system follows when an alert is set off and a call out sequence begins.

1. Click on **Menu**→**System**→**Settings**→**Phone settings**.
2. Set the following parameters:

Parameter	Description
Alarm time to start dialing	The amount of time the system waits after an alert is set off and the first number is called
Number of message repetitions	The number of times the alert message is repeated
No user interaction timeout	The amount of time the system waits between the end of one call and the beginning of another

Configuring Programmable Outputs

Different programmable outputs can be connected to the system and to the system modules. When correctly configured and assigned to the correct zones, the outputs can activate or deactivate equipment during an alert that could potentially save livestock.

Before You Begin

NOTE: *The programmable outputs must first be configured before being assigned to zones.*

1. Click on **Menu**→**System**→**Output**.
2. In edit mode, under the **General** tab, populate the following fields:
 - Name of output
 - Output location
 - Automatic, semi-automatic, or manual power mode

NOTE: *The semi-automatic power mode activates the output when an alert is set off, but the output can only be closed manually.*

- Cal zero (if needed)
 - Cal span (if needed)
3. Under the **Limits** tab, enter the high and low alert thresholds in amperes, off and on coil voltage trouble limits, load current trouble limit, and coil voltage.

NOTE: *The high and low alert thresholds in amperes as well as the Cal zero and Cal span can only be configured on the main system.*

Remember

You must activate the output by clicking on the activation button in edit mode, under the **General** tab.

Configuring Remote Listening

When you are a distance away from the main system and you would like to listen in on the activities going on near the main system, it is possible to do so with remote listening.

1. Click on **Menu**→**System**→**Settings**→**Phone settings**.
2. In edit mode, under the **General** tab, put a checkmark beside remote listening to indicate that an external microphone is hooked up to the system.

NOTE: *When calling the system to listen remotely, use the options to choose either the internal or external microphone to listen in.*

Configuring Technical Phone Line Settings

Technical specifications are required to configure the phone settings upon installation.

1. Click on **Menu**→**System**→**Settings**→**Phone settings**.
2. If needed, under the **Advanced** tab, use the + and - signs to adjust the following parameters or populate the fields:



Do not modify any parameters unless otherwise specified by a certified phone technician.

Dial tone wait time	Number of seconds the system must wait before starting dial tone detection. Ranges between 0 and 10 seconds
Receive gain	Increases the volume of voice reception. Ranges between -48dBm and -9dBm and increases by increments of 3dBm
Transmit gain	Increases the volume of the emitting voice. Ranges between -48dBm and -9dBm and increases by increments of 3dBm
DTMF tone duration	The length of a dual tone frequency impulse. Ranges between 0.01 seconds and 2.55 seconds and increases in increments of 0.01
DC impedance	Changes the DC termination impedance. Increases the line resistance. Choice between 50 and 800 ohms
Tip-ring voltage	Changes the Tip-Ring voltage for countries using a lower line voltage
DTMF LF and HF	Power frequency that makes up the tone. Ranges between -15dBm and -1dBm and increases by increments of 1 dBm
Ringer threshold	Choose the appropriate voltage, depending on the country, to detect the ringer
Measured line voltage	Measures the resting line voltage. An alert is set off if the voltage becomes too low (less than 3 volts)

Recording the System Name

Recording the name of the system lets you determine which system is in an alert or trouble state when you have more than one system on site.

1. Click on **Menu**→**System**→**Settings**→**Status and ID**.
2. In edit mode, under the **Message** tab, click on the red record button next to the language of your choice.

3. Clearly state the name of the system.

NOTE: *The amount of time remaining to record the name is displayed at the bottom of the page.*

4. Press on the black square to stop recording. You can listen to the recording by pressing the play button.
5. If you want to delete the recording, press on the garbage icon .
6. Repeat steps 2 through 4 to record the system name in another language.

Setting the System Trouble Recognition and Recovery Times

By setting the recognition and recovery times for system troubles, the system waits the recognition time before going into trouble state, and then waits for the system to return to a normal state for the amount of time indicated in the recovery time before coming out of a trouble state.

1. Click on **Menu**→**System**→**Settings**→**Status and ID**.
2. In edit mode, under the **General** tab, set the desired **System trouble recognition time** and **System trouble recovery time**.

Viewing and Resetting Output Circuits

If an output is tripped it is detected by the system and can be reset.

1. Click on **Menu**→**System**→**Settings**→**Status and ID**.
2. In edit mode, under the **General** tab, click on **Reset output circuits prot.** if the **Output circuits protection** is tripped.

NOTES

7 Zone Configuration

Topics Covered in this Chapter

- Zone Types
- Zone Configuration Settings

Zone Types

A zone is an input configured to respond to the type of sensor connected to a module. Different types of sensors can be connected to the system to monitor different alert types.

Table 7-1 List of the different zone types

Zone Type	Description
Indoor temperature	Used to monitor indoor temperatures. An alert is activated when the temperature reaches a high or low temperature threshold or varies outside a set temperature value from a temperature maturation curve.
Outdoor temperature	Used exclusively with an outdoor temperature probe. This zone is normally used to provide data used with the Outdoor Temperature Compensation feature. No more than one zone can be configured with this type.
Dry contact	Used to detect an open or closed circuit and some types of sensors.
Intrusion detection	Used to detect intrusion through normally open (NO) or normally closed (NC) circuits. This zone type cannot be assigned to a partition and cannot have either a recognition time or a recovery time.
4 – 20 mA input	Assigned to an input providing a 4 to 20 mA signal. A variety of sensors provide this kind of input.
0 – 5 V input	Used with sensors that provide a DC input between 0 and 5 volts.

Zone Configuration Settings

Before a zone can be monitored, it must be assigned to an input and the zone must be properly configured. There are many zone settings available for each zone type. Some settings are common to all zone types while others are specific to one zone type.

Table 7-2 List of the zone settings for each zone type

Setting	Indoor Temp.	Outdoor Temp.	Dry Contact	Intrusion Detection	4 - 20 mA Input	0 - 5 VDC Input
Zone Text Label	X	X	X	X	X	X
Partition Selection	X		X		X	X
Module Selection	X	X	X	X	X	X
Input Selection	X	X	X	X	X	X
Zone Type	X	X	X	X	X	X

Chapter 7: Zone Configuration

Table 7-2 List of the zone settings for each zone type (cont'd.)

Setting	Indoor Temp.	Outdoor Temp.	Dry Contact	Intrusion Detection	4 - 20 mA Input	0 - 5 VDC Input
Alert Recognition Time	X		X		X	X
Alert Recovery Time	X		X		X	X
Temperature Offset	X	X				
Temperature Probe Calibration offset	X	X				
Output Activation on Alert or Trouble	X	X (only trouble)	X	?	X	X
Alert Phone Call	X	X	X	X	X	X
Alert E-mail	X	X	X	X	X	X
Alert Texting (SMS)	X	X	X	X	X	X
Alert Siren	X	X	X	X	X	X
Internal Speaker	X	X	X	X	X	X
Zone Audio Label	X		X	X	X	X
Temperature Setpoint	X					
Temperature Maturation Curve	X					
Outdoor Temperature Compensation	X					
Cal. Zero (Zero calibration)					X	X
Cal. Span (Calibration span)					X	X

NOTE: All fields marked with an * on the user interface must be populated.

8 Configuring a Temperature Zone

Topics Covered in this Chapter

- Naming the Zone with a Text Label
- Selecting a Partition
- Selecting a Module
- Selecting an Input
- Selecting a Zone Type
- Setting the Alert Recognition Time
- Setting the Alert Recovery Time
- Activating the Temperature Curve
- Setting the High and Low Temperature Thresholds
- Setting the Critical Temperature Threshold
- Setting the Outdoor Temperature Compensation
- How it Works: Outdoor Temperature Compensation
- Activating a device in the Event of an Alert or Trouble
- Receiving a Phone Call When an Alert is Active
- Receiving an E-mail When an Alert is Active
- Enabling the Siren
- Enabling the Internal Speaker
- Recording the Zone Audio Label
- Resetting the Daily Minimum and Maximum
- Calibrating the Temperature Probe

Naming the Zone with a Text Label

The zone text label is a name you give to a zone to facilitate its identification. In addition to the zone number, the text label appears everywhere where the zone is identified in writing on the user interface.

1. In edit mode, under the **General** tab of the zone you are configuring, click on the edit field next to the **Name** button.
2. Type in the zone label of your choice.

NOTE: *The field is limited to 32 characters.*

Selecting a Partition

Partitions are used to group zones that are located in the same area or that are logically connected together. This can represent entire buildings or portions of a building. If you select the same partition in the zones belonging to a specific area, monitoring is done with one partition instead of several zones. Zones in a partition can also be bypassed and activated collectively.

What You Should Know

NOTE: *In order to be available for assignment, a partition must be created.*

Chapter 8: Configuring a Temperature Zone

1. In edit mode, Under the **General** tab, click on the edit field next to **Partition**.
2. Click in the circle to the left of the partition of your choice.

Figure 8-1 Example of a partition

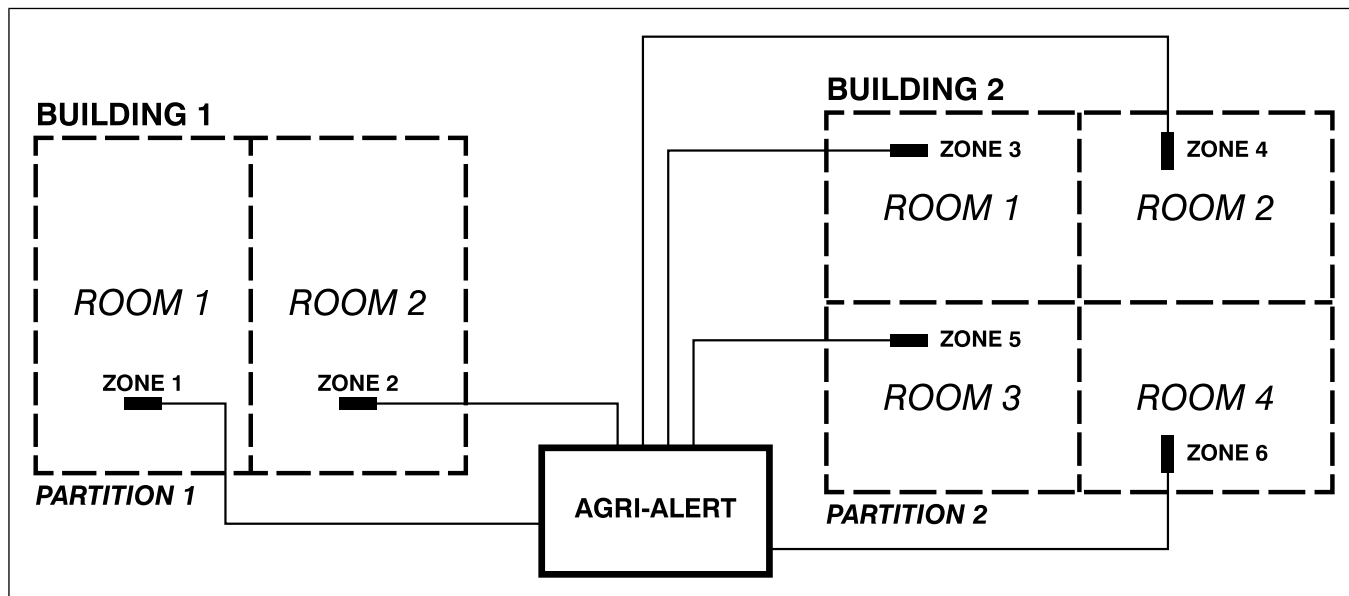

Selecting a Module

By selecting a module you link the zone to the area you want to monitor.

1. In edit mode, under the **General** tab, click on the **Module** edit field to display the selection box.
2. Select a module from the list.

NOTE: Only the modules that are connected to the system and that are initialized in the system are available for selection.

Selecting an Input

1. In edit mode, under the **General** tab, click on the **Input** edit field to display the selection box.
2. Select the input from the list.

Selecting a Zone Type

Selecting a zone type allows the system to properly interpret the data received from the selected input

What You Should Know

IMPORTANT: The selected zone type must correspond to the type of sensor associated with the input you selected.

1. In edit mode, under the **General** tab, click on the **Type** edit field to display the selection box.
2. Select a zone type from the list. Once a zone type has been selected, the configuration page displays the appropriate settings.

NOTE: The outdoor temperature zone type is not available if it has already been assigned to a zone.

Setting the Alert Recognition Time

The alert recognition time is used to calculate the set period of time before an alert condition is recognized and an alert set off. The zone must continuously be in an alert condition for a specific period of time before an alert is recognized and set off.

1. In edit mode, under the **General** tab of the zone you are configuring, click on the edit field next to the **Recognition** button.
2. Set the alert recognition time.

Figure 8-2 Graph displaying an example of an alert with an 8 second recognition time

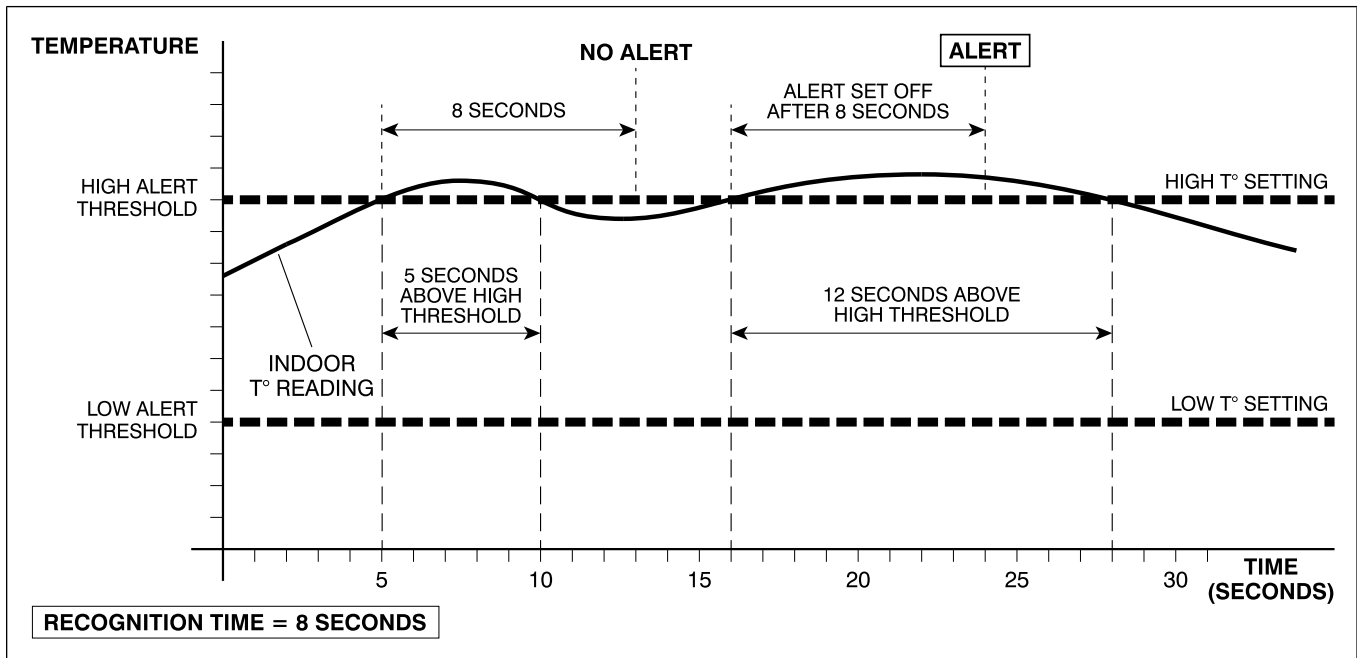

Setting the Alert Recovery Time

The alert recovery time is a set amount of time that a zone must remain within its normal range following an alert before a new alert can be set off.

1. In edit mode, under the **General** tab of the zone you are configuring, click on the edit field next to the **Recovery** button.
2. Set the alert recovery time.

Figure 8-3 Graph showing a zone in an alert state followed by a 10 second recovery time

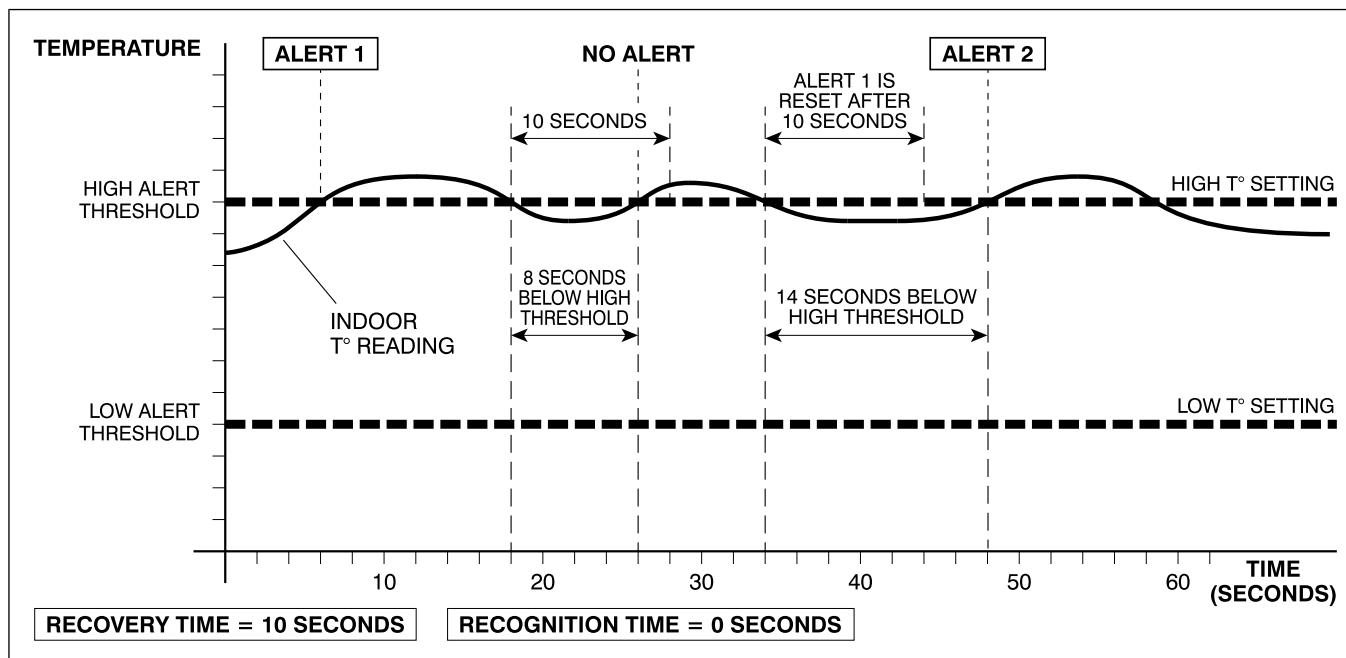

Activating the Temperature Curve

The temperature maturation curve allows you to monitor a temperature zone where the temperature is expected to gradually decrease over a period of days.

1. In edit mode, under the **Limits** tab, click on the **T° curve** button.

NOTE: *The temperature maturation curve is only available in temperature zones.*

2. If you want a temperature maturation curve different than **Default**, press on the curve selection button to display the selection list
3. Click on the circle to the left of the desired temperature maturation curve.
4. Click on the edit field next to the **High Offset** to display the input keypad and enter the high offset value.
5. Click on the edit field next to the **Low Offset** to display the input keypad and enter the low offset value.
6. If you want an age value different than **1**, select the **Age (days)** field to display the input keypad.
7. Select the starting day for your temperature maturation curve.

Figure 8-4 Graph showing an example of a maturation curve

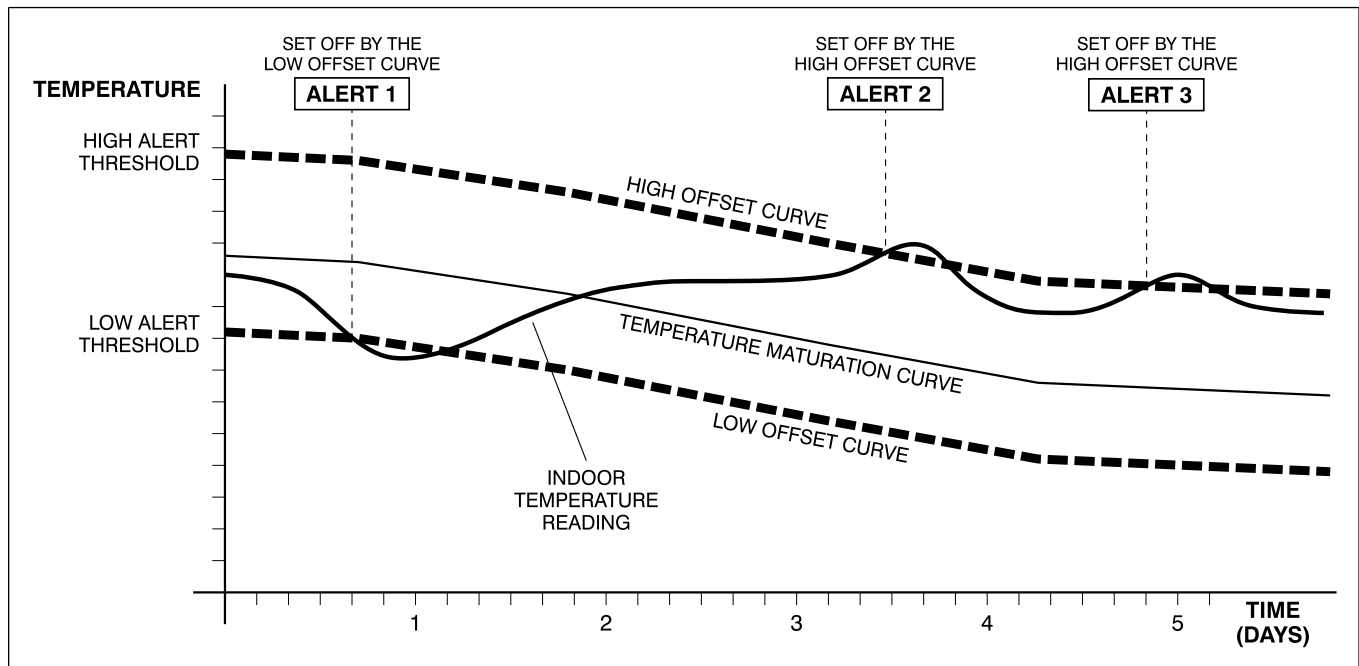

Setting the High and Low Temperature Thresholds

In a temperature zone, an alert is set off when the temperature is below or above the given temperature threshold.

What You Should Know

NOTE: *The temperature maturation curve must be disabled in order for the system to use the high and low temperature thresholds.*

1. In edit mode, under the **Limits** tab, click on the edit field next to the red bell.
2. Enter the high limit threshold using the keypad.
3. Click on the edit field next to the blue bell.
4. Enter the low limit threshold using the key pad.

Setting the Critical Temperature Threshold

At anytime, whether or not you are using the outdoor temperature compensation, if the temperature reaches the critical threshold, an alert is set off.

1. In edit mode, under the **Limits** tab, click on the edit field next to the **Critical T** button.
2. Use the keypad to enter the critical temperature.

Setting the Outdoor Temperature Compensation

During hot and cold weather periods, it is difficult to maintain a cool or warm indoor temperature. The outdoor temperature compensation lets the system take into account the outside temperature before setting off unnecessary alerts.

1. In edit mode, under the **Limits** tab, click on the box next to **External temperature compensation**.

The LED lights when the outdoor temperature compensation is enabled.

2. Click on the **Ext. offset** edit field to display the keypad. Enter the desired value.
3. Click on the **Critical** field to display the input keypad. Enter the desired value.

How it Works: Outdoor Temperature Compensation

The outdoor temperature compensation uses the outdoor temperature as a guide to raise the high alert threshold to avoid too many unnecessary alerts during hot weather periods. A maximum critical temperature is set as a protective measure.

During hot weather periods, it might be difficult or impossible to maintain cool indoor temperatures. The outdoor temperature compensation feature allows you to raise the indoor temperature high alert threshold to avoid an unnecessary high number of alerts.

In general, the indoor temperature is greater than the outdoor temperature by a certain number of degrees, this is the **Ext. offset** setting. The **Ext. offset** is added to the outdoor temperature reading to produce the high temperature limit. An alert is set off only when the indoor temperature rises above the high temperature limit. The **Ext. offset** value can be modified.

In addition, there is a critical temperature setting (**Critical**) that limits the high alert threshold to a maximum temperature. An alert is always set off when the zone temperature goes above the critical temperature, whatever the outdoor temperature.

Table 8-1 Controls for the outdoor temperature compensation feature

Description	Default Value
The outdoor temperature reading is given by an outdoor probe.	Reading
The outdoor offset is added to the outdoor temperature reading to produce the high temperature limit.	5 °F (2.8 °C)
The high temperature limit is calculated by adding the Ext. offset value to the outdoor temperature reading. Above this temperature, an alert is set off.	Calculated value
The critical temperature setting is the maximum allowable indoor temperature. An alert is always set off above this temperature setting.	95 °C (35 °C)
The check box allows to activates and deactivates the outdoor temperature compensation feature.	A checked box indicates the outdoor compensation feature is activated

The two figures below are very similar. Both show the implementation of the outdoor temperature compensation feature, one with the high-low temperature feature and the other with the temperature maturation curve feature.

An indoor temperature reading curve is added to show when alerts are set off. The low alert threshold (thickest bottom line) is not influenced by the outdoor temperature compensation feature settings.

Observe the influence of the outdoor temperature (outdoor temperature offset curve) on the high alert threshold (thickest top line). Also note that the high alert threshold will not go higher than the critical temperature setting.

Figure 8-5 Graph combining the high-low temperature and the outdoor temperature compensation features

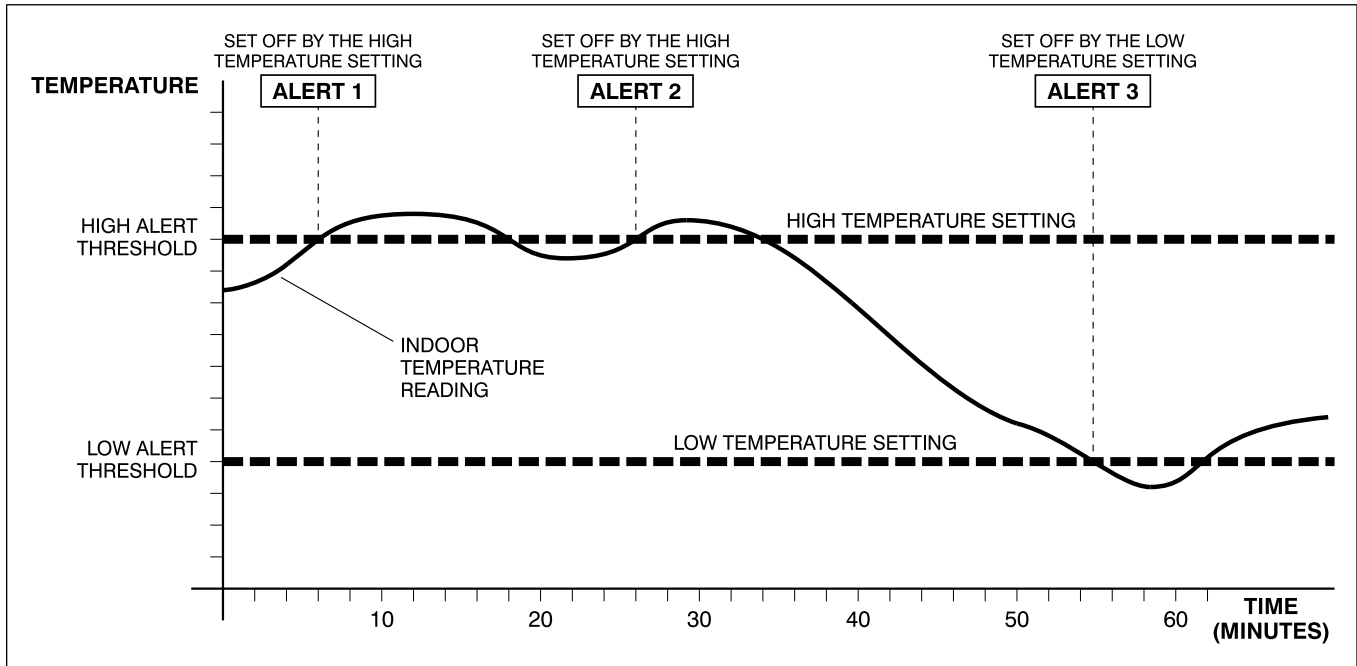
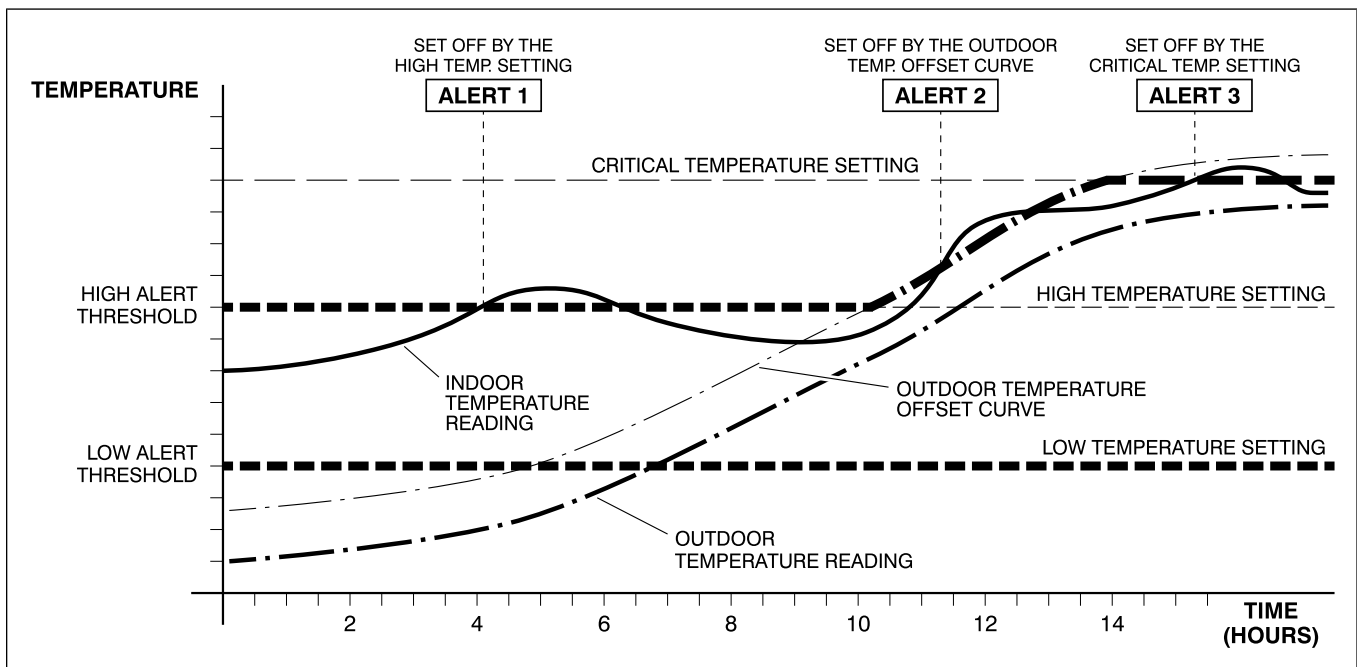

Figure 8-6 Graph combining the temperature maturation curve and the outdoor temperature compensation features



Activating a device in the Event of an Alert or Trouble

A device, such as a fan or a heater, can be turned on or off when an alert condition or trouble is detected in a zone. To do so, a programmable output must be activated in the zone.

1. In edit mode, under the **Action** tab, click on the edit field next to the event type you want the device's output linked to.

A list of available outputs is displayed.

NOTE: *Only the previously configured outputs are displayed.*

2. Click in the box to the left of the chosen output.

Receiving a Phone Call When an Alert is Active

In the event of an alert in a zone, the system calls the phone numbers selected to inform key people of the alert state.

What You Should Know

NOTE: *The phone numbers and phone groups must first be entered in the system menu.*

1. In edit mode, under the **Action** tab of the zone you are configuring, click on the edit field next to the telephone icon .
2. Click in the box to the left the contact person or group you would like to be notified in the event of an alert in the given zone.

After You Finish

Make sure to record the message you want your system to play when calling.

Receiving an E-mail When an Alert is Active

When an alert is present in a zone, the system sends the assigned contact group an e-mail to inform them of the situation. Receiving an e-mail when an alert is activated allows you to be alerted even when you are on the phone or out of the country.

Before You Begin

NOTE: *E-mail addresses but first be entered in the **Menu**→**System**→**Contacts** to be available for selection.*

1. In edit mode, under the **Action** tab of the zone you are configuring, click on the edit field next to the e-mail icon .
2. Choose the e-mail addresses to contact from the list.

Enabling the Siren

If you install a siren, you can chose to make it sound or not when an alert is set off in a zone.

Before You Begin

NOTE: *A siren must be installed and connected to your system for this feature to work.*

In edit mode, under the **Action** tab of the zone you are configuring, click on the edit field next to siren icon .

A check mark indicates the siren is enabled.

Enabling the Internal Speaker

The internal speaker allows you to hear the alert messages from the system when you are near the main system.

In edit mode, under the **Action** tab of the zone you are configuring, click on the edit field next to the speaker icon .

A check mark indicates the internal speaker is enabled.

Recording the Zone Audio Label

The audio label is the name the system repeats to identify the zone when calling because an alert is set off in the zone.

1. In edit mode, under the **Mess.** tab of the zone you are configuring, click on the record icon .



NOTE: *The time remaining to record the audio label starts counting down once you press the record button.*

Tip

For consistency, use the same words as you used when giving the **Name** in the zone's **General** tab.

2. State the zone audio label clearly.

NOTE: *The recording stops when it has reached the allowed time of 8 seconds.*

3. Click on the play icon  to listen to the recording.
4. If the recording is not satisfactory, press the garbage icon  to delete the recording and start over.
5. Repeat steps 2 through 5 to record the zone audio label in another language.

Resetting the Daily Minimum and Maximum

The system monitors and constantly updates the minimum and maximum values reached within a 24 hour period. The time of the recorded minimum and maximum values is displayed. After 24 hours, the values are reset and the monitoring starts anew.

In status mode, under the **General** tab in the zone you are configuring, click on the **Reset min/max**.

The information beside the **Max 24h** and **Min 24h** buttons is reset.

Calibrating the Temperature Probe

Although temperature probes are manufactured with high accuracy, some probes might show slight measurement variations. The probe calibration allows you to compensate for such a variation by up to $\pm 10^\circ\text{F}$ ($\pm 5.5^\circ\text{C}$) with an accuracy of one tenth of a degree

1. In edit mode, under the **Calibration** tab, click on the edit field next to the **Offset** button to display the keypad.
2. Enter the impedance offset in ohms.
3. Enter the temperature offset and the low and high trouble impedances.

NOTE: *Enter value from left to right and always enter a decimal value. For example, a value of 1°F requires you to enter 10 to obtain 1.0°F .*

Use the +/- button to change between a positive and a negative value.

For example, if a probe shows a measurement difference of $+ 1.3^\circ\text{F}$ from the actual temperature, you must enter $- 1.3^\circ\text{F}$ to calibrate the probe.

9 Configuring a 0-5 Volt Zone Type

Topics Covered in this Chapter

- Naming the Zone with a Text Label
- Selecting a Partition
- Selecting a Module
- Selecting an Input
- Selecting a Zone Type
- Resetting the Daily Minimum and Maximum
- Setting the Alert Recognition Time
- Setting the Alert Recovery Time
- Selecting the Unit of Measure
- Entering the Minimum and Maximum Values for an Input
- Activating a device in the Event of an Alert or Trouble
- Receiving a Phone Call When an Alert is Active
- Receiving an E-mail When an Alert is Active
- Enabling the Siren
- Enabling the Internal Speaker
- Recording the Zone Audio Label
- Viewing Zone Calibration
- Calibrating the Sensor Outputs
- Setting the Calibration Zero and Calibration Span
- How it Works: Calibration Zero and Calibration Span

Naming the Zone with a Text Label

The zone text label is a name you give to a zone to facilitate its identification. In addition to the zone number, the text label appears everywhere where the zone is identified in writing on the user interface.

1. In edit mode, under the **General** tab of the zone you are configuring, click on the edit field next to the **Name** button.
2. Type in the zone label of your choice.

NOTE: *The field is limited to 32 characters.*

Selecting a Partition

Partitions are used to group zones that are located in the same area or that are logically connected together. This can represent entire buildings or portions of a building. If you select the same partition in the zones belonging to a specific area, monitoring is done with one partition instead of several zones. Zones in a partition can also be bypassed and activated collectively.

What You Should Know

NOTE: *In order to be available for assignment, a partition must be created.*

Chapter 9: Configuring a 0-5 Volt Zone Type

1. In edit mode, Under the **General** tab, click on the edit field next to **Partition**.
2. Click in the circle to the left of the partition of your choice.

Figure 9-1 Example of a partition

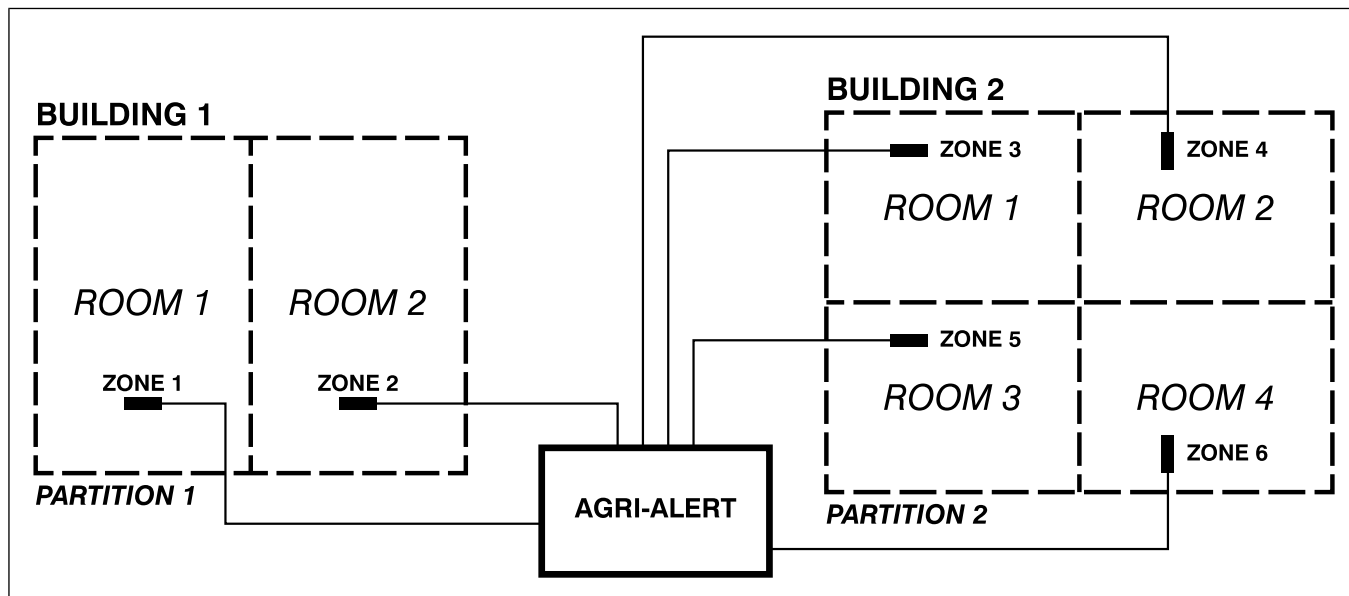

Selecting a Module

By selecting a module you link the zone to the area you want to monitor.

1. In edit mode, under the **General** tab, click on the **Module** edit field to display the selection box.
2. Select a module from the list.

NOTE: Only the modules that are connected to the system and that are initialized in the system are available for selection.

Selecting an Input

1. In edit mode, under the **General** tab, click on the **Input** edit field to display the selection box.
2. Select the input from the list.

Selecting a Zone Type

Selecting a zone type allows the system to properly interpret the data received from the selected input

What You Should Know

IMPORTANT: The selected zone type must correspond to the type of sensor associated with the input you selected.

1. In edit mode, under the **General** tab, click on the **Type** edit field to display the selection box.
2. Select a zone type from the list. Once a zone type has been selected, the configuration page displays the appropriate settings.

NOTE: The outdoor temperature zone type is not available if it has already been assigned to a zone.

Resetting the Daily Minimum and Maximum

The system monitors and constantly updates the minimum and maximum values reached within a 24 hour period. The time of the recorded minimum and maximum values is displayed. After 24 hours, the values are reset and the monitoring starts anew.

In status mode, under the **General** tab in the zone you are configuring, click on the **Reset min/max**.

The information beside the **Max 24h** and **Min 24h** buttons is reset.

Setting the Alert Recognition Time

The alert recognition time is used to calculate the set period of time before an alert condition is recognized and an alert set off. The zone must continuously be in an alert condition for a specific period of time before an alert is recognized and set off.

1. In edit mode, under the **General** tab of the zone you are configuring, click on the edit field next to the **Recognition** button.
2. Set the alert recognition time.

Figure 9-2 Graph displaying an example of an alert with an 8 second recognition time

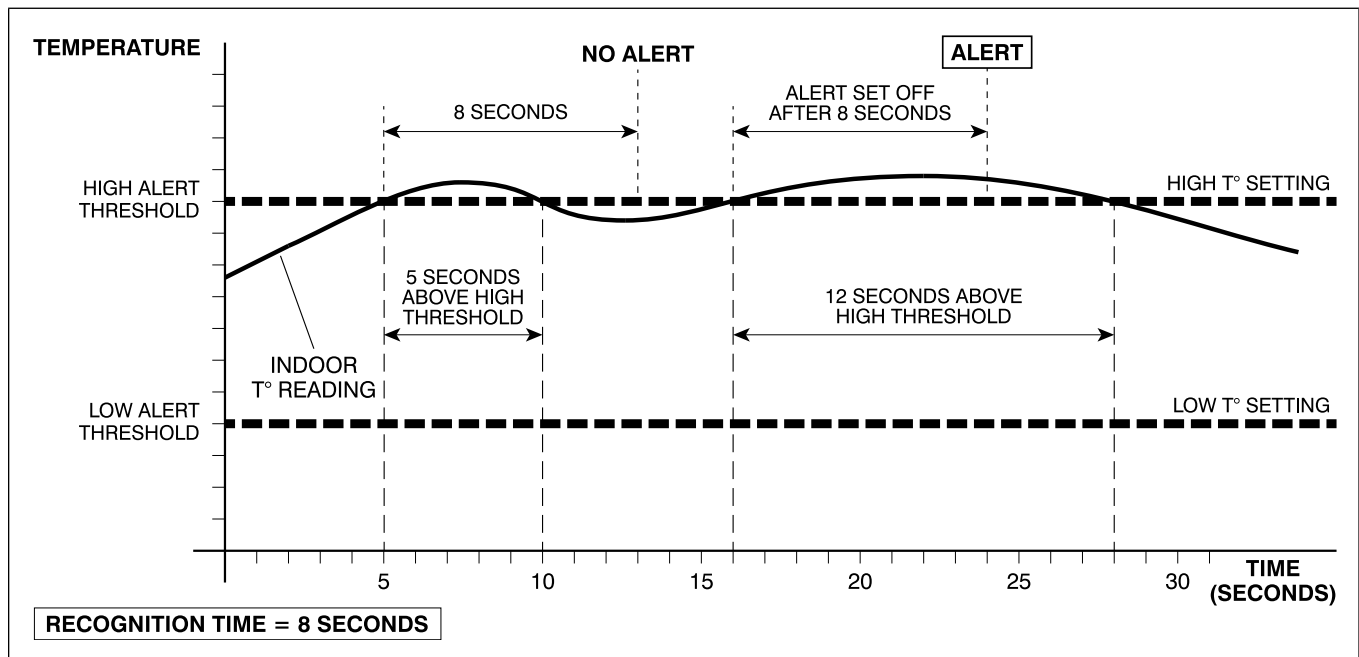

Setting the Alert Recovery Time

The alert recovery time is a set amount of time that a zone must remain within its normal range following an alert before a new alert can be set off.

1. In edit mode, under the **General** tab of the zone you are configuring, click on the edit field next to the **Recovery** button.
2. Set the alert recovery time.

Figure 9-3 Graph showing a zone in an alert state followed by a 10 second recovery time

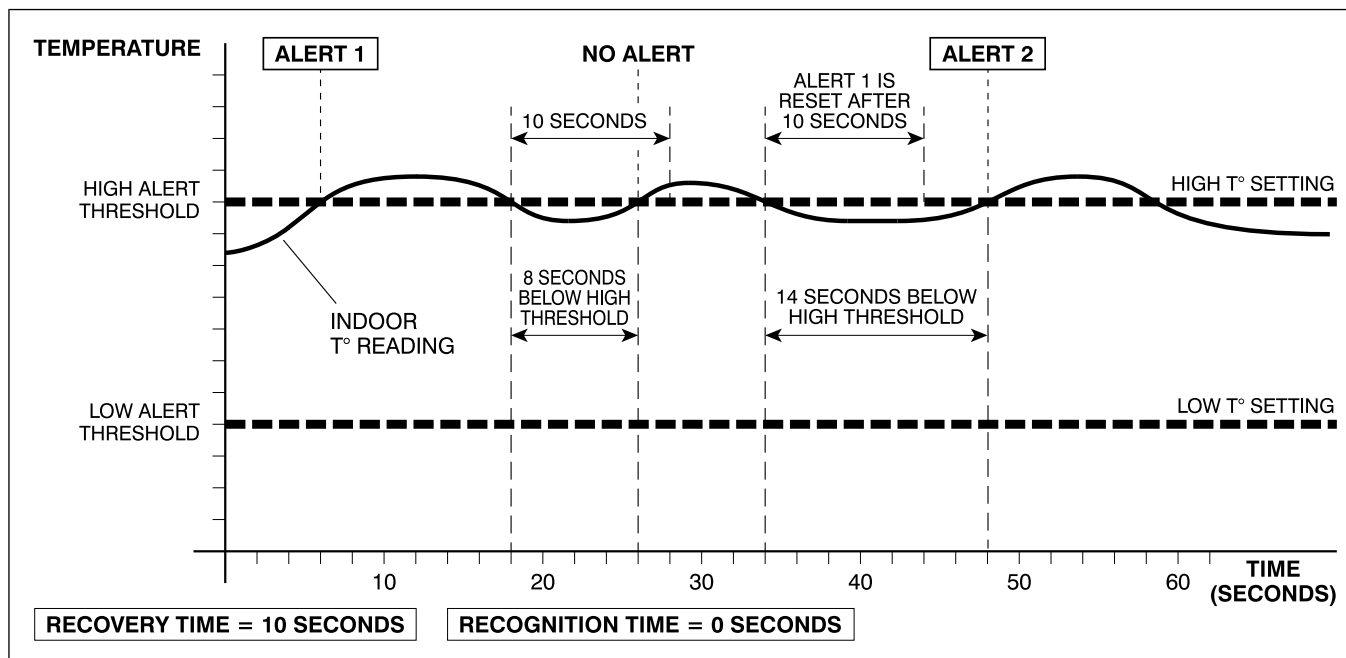

Selecting the Unit of Measure

Selecting the correct units of measure for the input facilitates the reading of alert thresholds at a glance.

1. In edit mode, under the **General** tab, click on the edit field next to the **Unit** button.
2. Select the units of measure to display according to the input connected to the zone.

Entering the Minimum and Maximum Values for an Input

1. In edit mode, under the **General** tab, click in the edit field next to the **Min** button.
2. Enter the minimum value measured by your input using the keypad.
3. Click in the edit field next to the **Max** button.
4. Enter the maximum value measured by your input using the keypad.

Activating a device in the Event of an Alert or Trouble

A device, such as a fan or a heater, can be turned on or off when an alert condition or trouble is detected in a zone. To do so, a programmable output must be activated in the zone.

1. In edit mode, under the **Action** tab, click on the edit field next to the event type you want the device's output linked to.

A list of available outputs is displayed.

NOTE: Only the previously configured outputs are displayed.

2. Click in the box to the left of the chosen output.

Receiving a Phone Call When an Alert is Active

In the event of an alert in a zone, the system calls the phone numbers selected to inform key people of the alert state.

What You Should Know

NOTE: *The phone numbers and phone groups must first be entered in the system menu.*

1. In edit mode, under the **Action** tab of the zone you are configuring, click on the edit field next to the telephone icon .
2. Click in the box to the left the contact person or group you would like to be notified in the event of an alert in the given zone.

After You Finish

Make sure to record the message you want your system to play when calling.

Receiving an E-mail When an Alert is Active

When an alert is present in a zone, the system sends the assigned contact group an e-mail to inform them of the situation. Receiving an e-mail when an alert is activated allows you to be alerted even when you are on the phone or out of the country.

Before You Begin

NOTE: *E-mail addresses must first be entered in the **Menu**→**System**→**Contacts** to be available for selection.*

1. In edit mode, under the **Action** tab of the zone you are configuring, click on the edit field next to the e-mail icon .
2. Choose the e-mail addresses to contact from the list.

Enabling the Siren

If you install a siren, you can choose to make it sound or not when an alert is set off in a zone.

Before You Begin

NOTE: *A siren must be installed and connected to your system for this feature to work.*

In edit mode, under the **Action** tab of the zone you are configuring, click on the edit field next to siren icon .

A check mark indicates the siren is enabled.

Enabling the Internal Speaker

The internal speaker allows you to hear the alert messages from the system when you are near the main system.

In edit mode, under the **Action** tab of the zone you are configuring, click on the edit field next to the speaker icon .

A check mark indicates the internal speaker is enabled.

Recording the Zone Audio Label

The audio label is the name the system repeats to identify the zone when calling because an alert is set off in the zone.

1. In edit mode, under the **Mess.** tab of the zone you are configuring, click on the record icon .



NOTE: *The time remaining to record the audio label starts counting down once you press the record button.*

Tip

For consistency, use the same words as you used when giving the **Name** in the zone's **General** tab.

2. State the zone audio label clearly.

NOTE: *The recording stops when it has reached the allowed time of 8 seconds.*

3. Click on the play icon  to listen to the recording.
4. If the recording is not satisfactory, press the garbage icon  to delete the recording and start over.
5. Repeat steps 2 through 5 to record the zone audio label in another language.

Viewing Zone Calibration

In addition to system diagnostics, you can view the zone calibration in the zone itself.

In status mode, under the **Message** tab, click on the **Calibration** button.

Trouble limits, raw and calibrated data is displayed.

The green LED lights when the **Calibration** button is enabled

Calibrating the Sensor Outputs

To correct a possible zero or span error, it is important to calibrate the sensor outputs.

1. Using a 0 to 300 PSI pressure sensor, measure the sensor's output. The output should read 0 volts.
2. If the reading isn't 0, enter the the value with an inverted sign in the appropriate field. This becomes the **b** value in our equation.
3. Measure the output once more while at its maximum stimulation. The output should read 5 volts. If it doesn't, perform the following equation:

Maximum value of the input / (value generated by the sensor - the offset)

For example, 5 volts / (6 volts - 0,4 volts) = 0.89 span.

NOTE: *The span entered by the user is not the m but rather the ratio between the normal curve and the correction.*

Setting the Calibration Zero and Calibration Span

Setting the calibration zero and calibration span ensures accuracy in the values being monitored by the system in the event that an input is not calibrated.

What You Should Know

The calibration zero and calibration span only need to be entered if the input calibration is incorrect.

1. In edit mode, under the **General** tab, click on the edit field beside the **Cal. Zero** button.
2. Enter the zero calibration.
3. Click on the edit field next to the **Cal. Span** button.
4. Enter the calibration span.

How it Works: Calibration Zero and Calibration Span

Calibrating the zero and span errors allow the installer to correct the output of a sensor. A sensor output is viewed as a linear function $y = mx + b$

Sensors that are not calibrated can generate span or zero errors as illustrated in the figures below:

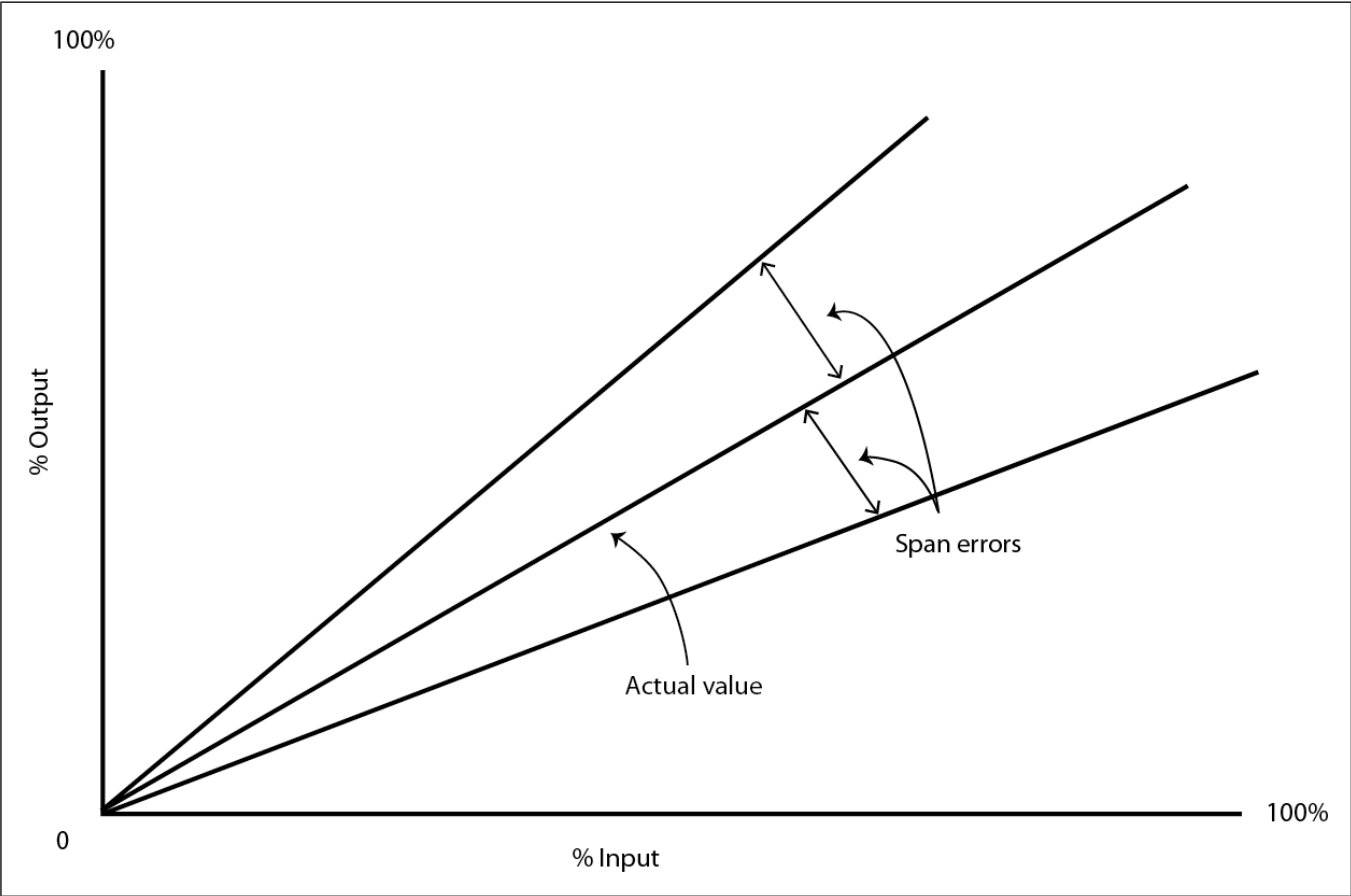

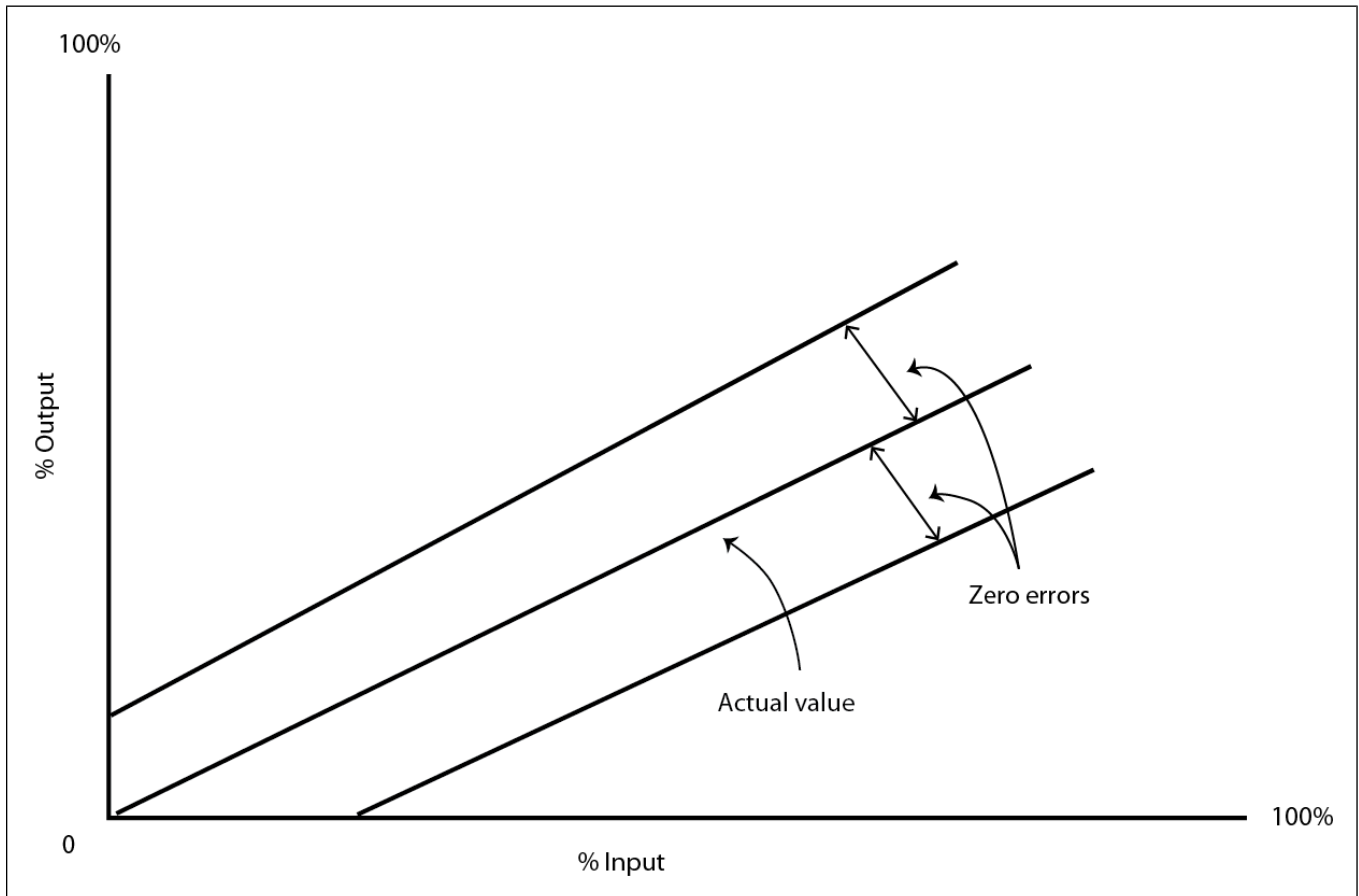

To correct the problem, the output of the sensor must be calibrated to be linear and represent the measure.

You can also use the calibration zero and span to get a range specific to the sensor output. For example, if you want a reading with a range of 0 to 250 PSI, you can adjust the span so that when the sensor reads 250 PSI, the input of the system indicates 20 mA. With a 0,000016 mA by PSI, to get 16 mA at 250 PSI, the span must be 4. By adjusting the readings, you are playing with the gain and offset to have readings reflect your sensor's range.

NOTES

10 Configuring a 4 - 20mA Zone Type

Topics Covered in this Chapter

- Naming the Zone with a Text Label
- Selecting a Partition
- Selecting a Module
- Selecting an Input
- Selecting a Zone Type
- Setting the Alert Recognition Time
- Setting the Alert Recovery Time
- Resetting the Daily Minimum and Maximum
- Selecting the Unit of Measure
- Entering the Minimum and Maximum Values for an Input
- Activating a device in the Event of an Alert or Trouble
- Receiving a Phone Call When an Alert is Active
- Receiving an E-mail When an Alert is Active
- Enabling the Siren
- Enabling the Internal Speaker
- Recording the Zone Audio Label
- Calibrating the Sensor Outputs
- Setting the Calibration Zero and Calibration Span
- How it Works: Calibration Zero and Calibration Span
- Viewing Zone Calibration

Naming the Zone with a Text Label

The zone text label is a name you give to a zone to facilitate its identification. In addition to the zone number, the text label appears everywhere where the zone is identified in writing on the user interface.

1. In edit mode, under the **General** tab of the zone you are configuring, click on the edit field next to the **Name** button.
2. Type in the zone label of your choice.

NOTE: *The field is limited to 32 characters.*

Selecting a Partition

Partitions are used to group zones that are located in the same area or that are logically connected together. This can represent entire buildings or portions of a building. If you select the same partition in the zones belonging to a specific area, monitoring is done with one partition instead of several zones. Zones in a partition can also be bypassed and activated collectively.

What You Should Know

NOTE: *In order to be available for assignment, a partition must be created.*

1. In edit mode, Under the **General** tab, click on the edit field next to **Partition**.
2. Click in the circle to the left of the partition of your choice.

Figure 10-1 *Example of a partition*

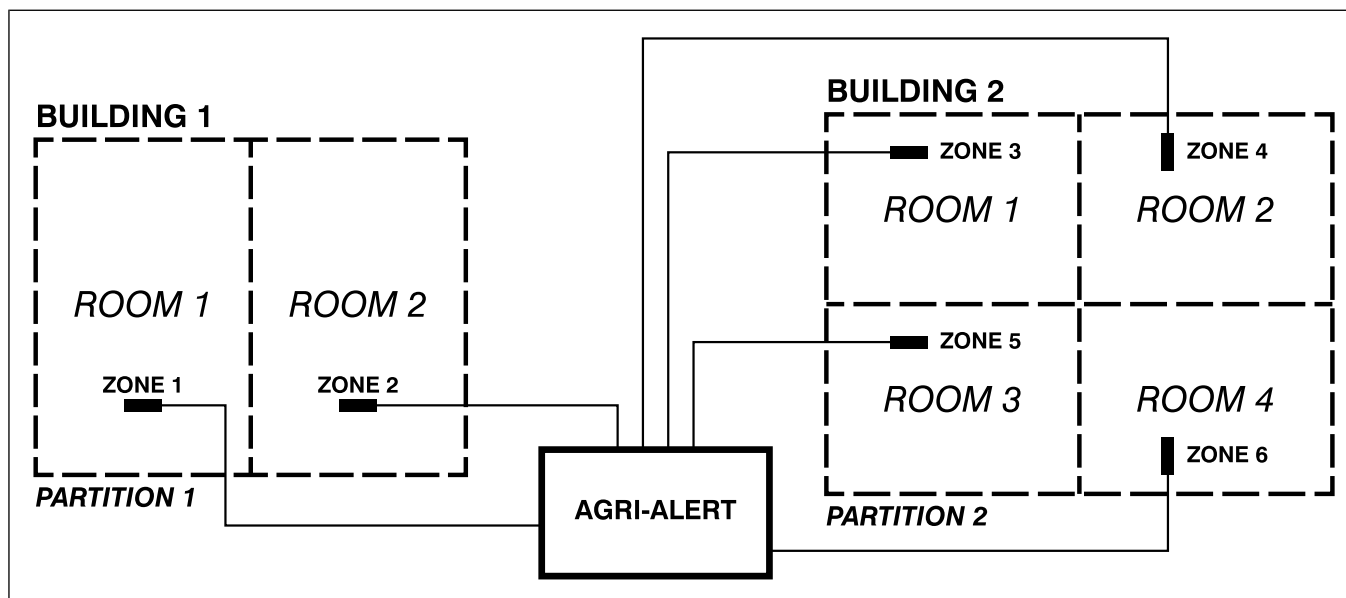

Selecting a Module

By selecting a module you link the zone to the area you want to monitor.

1. In edit mode, under the **General** tab, click on the **Module** edit field to display the selection box.
2. Select a module from the list.

NOTE: *Only the modules that are connected to the system and that are initialized in the system are available for selection.*

Selecting an Input

1. In edit mode, under the **General** tab, click on the **Input** edit field to display the selection box.
2. Select the input from the list.

Selecting a Zone Type

Selecting a zone type allows the system to properly interpret the data received from the selected input

What You Should Know

IMPORTANT: *The selected zone type must correspond to the type of sensor associated with the input you selected.*

1. In edit mode, under the **General** tab, click on the **Type** edit field to display the selection box.
2. Select a zone type from the list. Once a zone type has been selected, the configuration page displays the appropriate settings.

NOTE: The outdoor temperature zone type is not available if it has already been assigned to a zone.

Setting the Alert Recognition Time

The alert recognition time is used to calculate the set period of time before an alert condition is recognized and an alert set off. The zone must continuously be in an alert condition for a specific period of time before an alert is recognized and set off.

1. In edit mode, under the **General** tab of the zone you are configuring, click on the edit field next to the **Recognition** button.
2. Set the alert recognition time.

Figure 10-2 Graph displaying an example of an alert with an 8 second recognition time

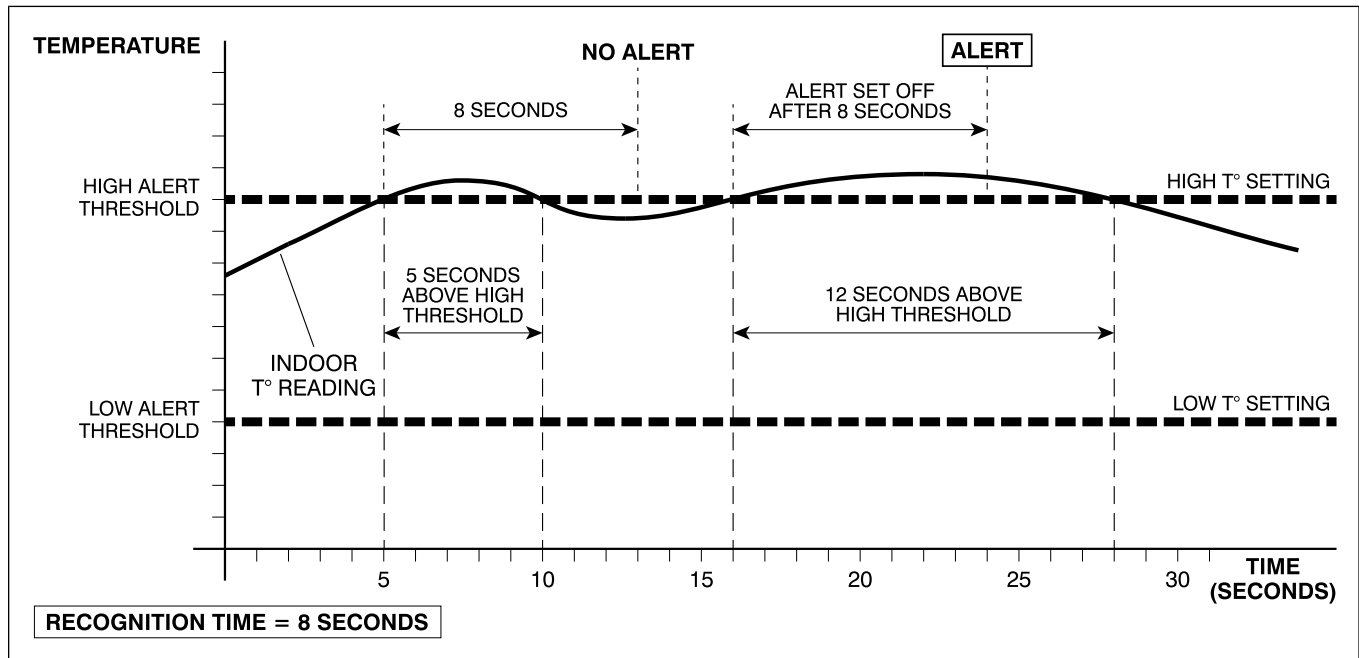

Setting the Alert Recovery Time

The alert recovery time is a set amount of time that a zone must remain within its normal range following an alert before a new alert can be set off.

1. In edit mode, under the **General** tab of the zone you are configuring, click on the edit field next to the **Recovery** button.
2. Set the alert recovery time.

Figure 10-3 Graph showing a zone in an alert state followed by a 10 second recovery time

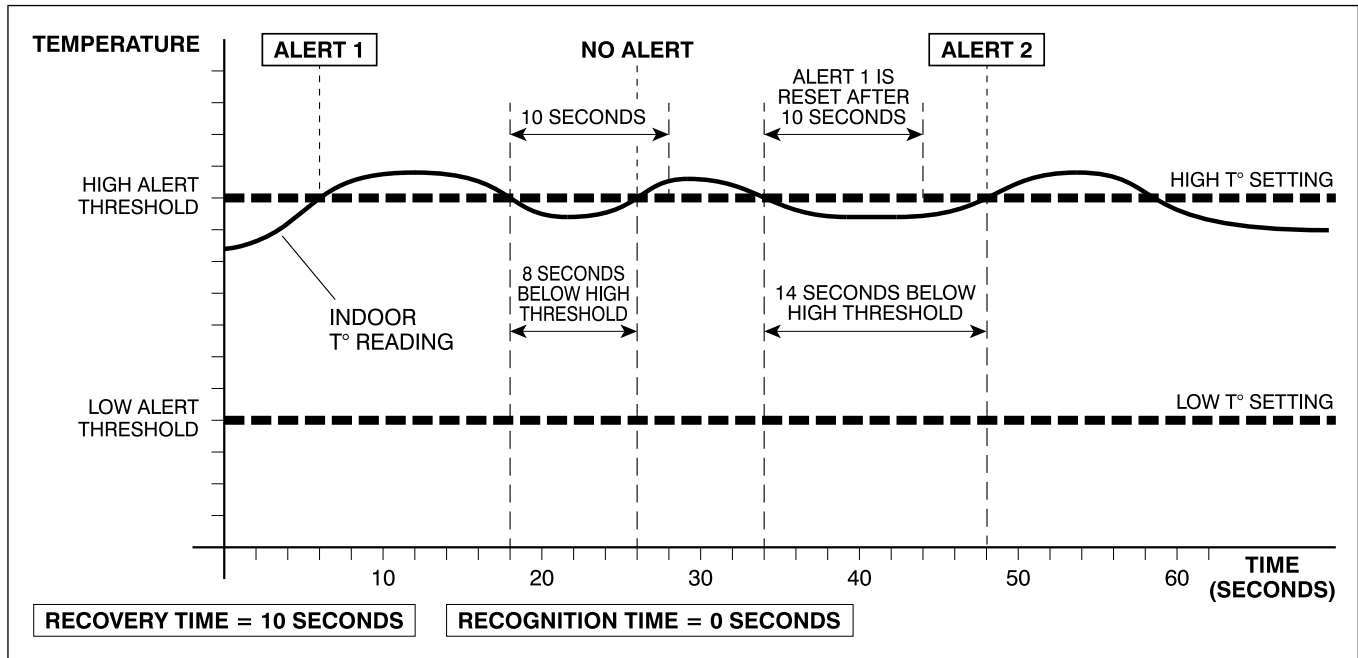

Resetting the Daily Minimum and Maximum

The system monitors and constantly updates the minimum and maximum values reached within a 24 hour period. The time of the recorded minimum and maximum values is displayed. After 24 hours, the values are reset and the monitoring starts anew.

In status mode, under the **General** tab in the zone you are configuring, click on the **Reset min/max**.

The information beside the **Max 24h** and **Min 24h** buttons is reset.

Selecting the Unit of Measure

Selecting the correct units of measure for the input facilitates the reading of alert thresholds at a glance.

1. In edit mode, under the **General** tab, click on the edit field next to the **Unit** button.
2. Select the units of measure to display according to the input connected to the zone.

Entering the Minimum and Maximum Values for an Input

1. In edit mode, under the **General** tab, click in the edit field next to the **Min** button.
2. Enter the minimum value measured by your input using the keypad.
3. Click in the edit field next to the **Max** button.
4. Enter the maximum value measured by your input using the keypad.

Activating a device in the Event of an Alert or Trouble

A device, such as a fan or a heater, can be turned on or off when an alert condition or trouble is detected in a zone. To do so, a programmable output must be activated in the zone.

1. In edit mode, under the **Action** tab, click on the edit field next to the event type you want the device's output linked to.

A list of available outputs is displayed.

NOTE: *Only the previously configured outputs are displayed.*

2. Click in the box to the left of the chosen output.

Receiving a Phone Call When an Alert is Active

In the event of an alert in a zone, the system calls the phone numbers selected to inform key people of the alert state.

What You Should Know

NOTE: *The phone numbers and phone groups must first be entered in the system menu.*

1. In edit mode, under the **Action** tab of the zone you are configuring, click on the edit field next to the telephone icon .
2. Click in the box to the left the contact person or group you would like to be notified in the event of an alert in the given zone.

After You Finish

Make sure to record the message you want your system to play when calling.

Receiving an E-mail When an Alert is Active

When an alert is present in a zone, the system sends the assigned contact group an e-mail to inform them of the situation. Receiving an e-mail when an alert is activated allows you to be alerted even when you are on the phone or out of the country.

Before You Begin

NOTE: *E-mail addresses but first be entered in the **Menu**→**System**→**Contacts** to be available for selection.*

1. In edit mode, under the **Action** tab of the zone you are configuring, click on the edit field next to the e-mail icon .
2. Choose the e-mail addresses to contact from the list.

Enabling the Siren

If you install a siren, you can chose to make it sound or not when an alert is set off in a zone.

Before You Begin

NOTE: *A siren must be installed and connected to your system for this feature to work.*

In edit mode, under the **Action** tab of the zone you are configuring, click on the edit field next to siren icon .

A check mark indicates the siren is enabled.

Enabling the Internal Speaker

The internal speaker allows you to hear the alert messages from the system when you are near the main system.

In edit mode, under the **Action** tab of the zone you are configuring, click on the edit field next to the speaker icon .

A check mark indicates the internal speaker is enabled.

Recording the Zone Audio Label

The audio label is the name the system repeats to identify the zone when calling because an alert is set off in the zone.

1. In edit mode, under the **Mess.** tab of the zone you are configuring, click on the record icon .



NOTE: *The time remaining to record the audio label starts counting down once you press the record button.*

Tip

For consistency, use the same words as you used when giving the **Name** in the zone's **General** tab.

2. State the zone audio label clearly.

NOTE: *The recording stops when it has reached the allowed time of 8 seconds.*

3. Click on the play icon  to listen to the recording.
4. If the recording is not satisfactory, press the garbage icon  to delete the recording and start over.
5. Repeat steps 2 through 5 to record the zone audio label in another language.

Calibrating the Sensor Outputs

To correct a possible zero or span error, it is important to calibrate the sensor outputs.

1. Using a 0 to 300 PSI pressure sensor, measure the sensor's output. The output should read 0 volts.
2. If the reading isn't 0, enter the the value with an inverted sign in the appropriate field. This becomes the **b** value in our equation.
3. Measure the output once more while at its maximum stimulation. The output should read 5 volts. If it doesn't, perform the following equation:

Maximum value of the input / (value generated by the sensor - the offset)

For example, 5 volts / (6 volts - 0,4 volts) = 0.89 span.

NOTE: *The span entered by the user is not the m but rather the ratio between the normal curve and the correction.*

Setting the Calibration Zero and Calibration Span

Setting the calibration zero and calibration span ensures accuracy in the values being monitored by the system in the event that an input is not calibrated.

What You Should Know

The calibration zero and calibration span only need to be entered if the input calibration is incorrect.

1. In edit mode, under the **General** tab, click on the edit field beside the **Cal. Zero** button.
2. Enter the zero calibration.
3. Click on the edit field next to the **Cal. Span** button.
4. Enter the calibration span.

How it Works: Calibration Zero and Calibration Span

Calibrating the zero and span errors allow the installer to correct the output of a sensor. A sensor output is viewed as a linear function $y = mx + b$

Sensors that are not calibrated can generate span or zero errors as illustrated in the figures below:

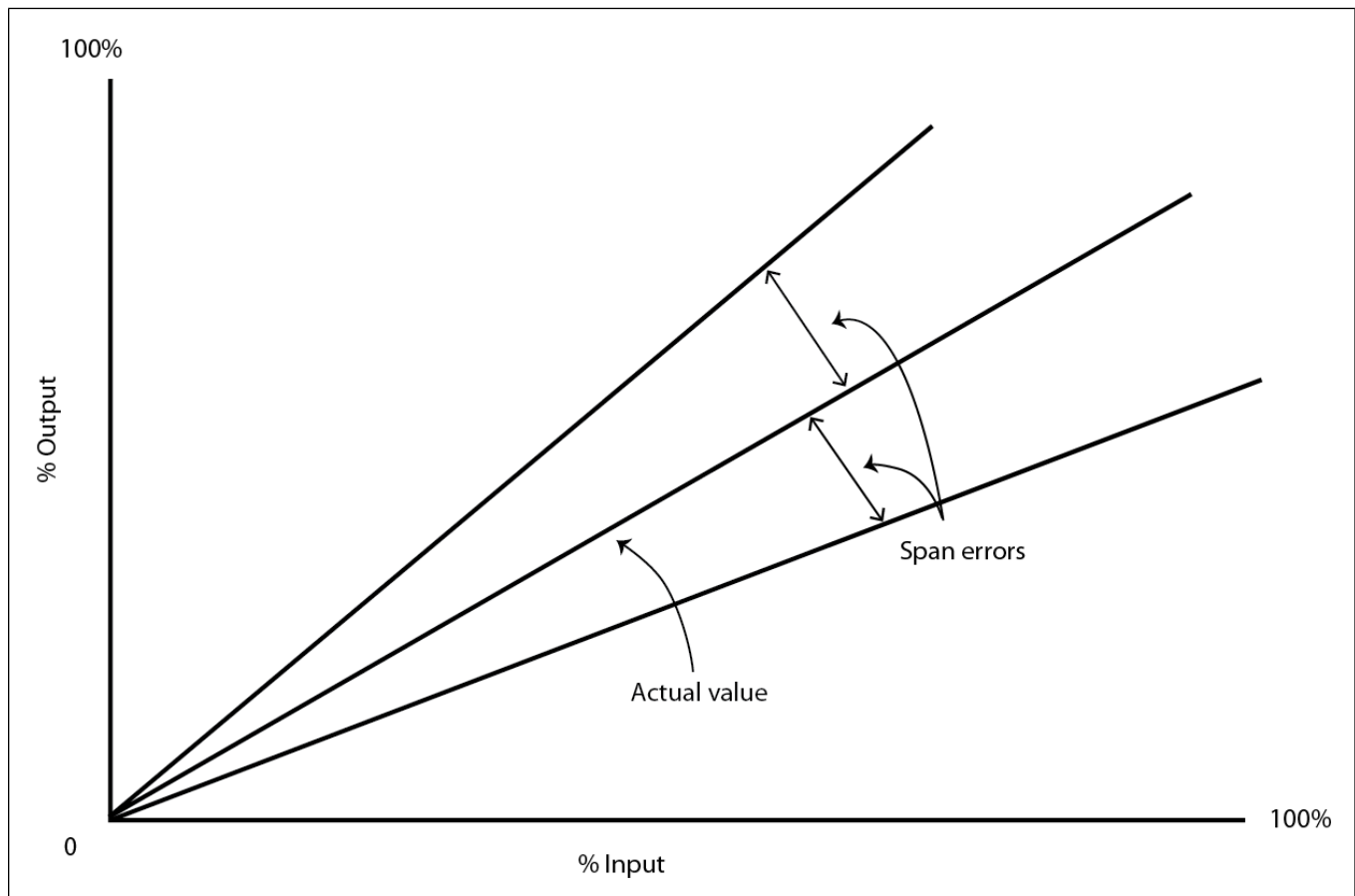

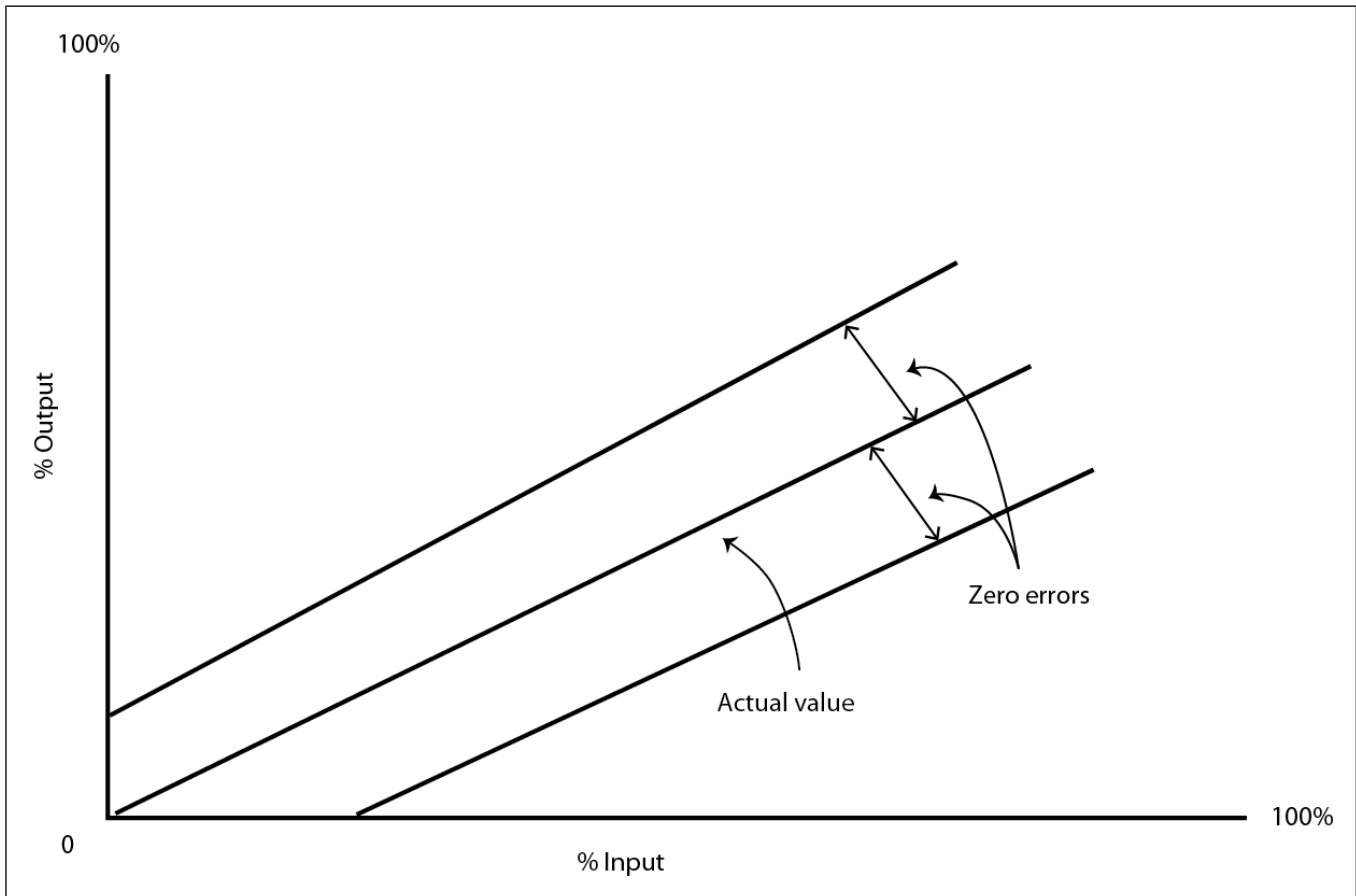

To correct the problem, the output of the sensor must be calibrated to be linear and represent the measure.

You can also use the calibration zero and span to get a range specific to the sensor output. For example, if you want a reading with a range of 0 to 250 PSI, you can adjust the span so that when the sensor reads 250 PSI, the input of the system indicates 20 mA. With a 0,000016 mA by PSI, to get 16 mA at 250 PSI, the span must be 4. By adjusting the readings, you are playing with the gain and offset to have readings reflect your sensor's range.

Viewing Zone Calibration

In addition to system diagnostics, you can view the zone calibration in the zone itself.

In status mode, under the **Message** tab, click on the **Calibration** button.

Trouble limits, raw and calibrated data is displayed.

The green LED lights when the **Calibration** button is enabled

11 Configuring a Dry Contact Zone

Topics Covered in this Chapter

- Naming the Zone with a Text Label
- Selecting a Partition
- Selecting a Module
- Selecting an Input
- Selecting a Zone Type
- Setting the Alert Recognition Time
- Setting the Alert Recovery Time
- Resetting the Daily Minimum and Maximum
- Choosing the Type of End of Line Resistor
- Selecting the Type of Contact in the Dry Contact Zone
- Activating a device in the Event of an Alert or Trouble
- Receiving a Phone Call When an Alert is Active
- Receiving an E-mail When an Alert is Active
- Enabling the Siren
- Enabling the Internal Speaker
- Recording the Zone Audio Label
- Viewing Zone Calibration
- Calibrating the Zone Trouble Thresholds

Naming the Zone with a Text Label

The zone text label is a name you give to a zone to facilitate its identification. In addition to the zone number, the text label appears everywhere where the zone is identified in writing on the user interface.

1. In edit mode, under the **General** tab of the zone you are configuring, click on the edit field next to the **Name** button.
2. Type in the zone label of your choice.

NOTE: *The field is limited to 32 characters.*

Selecting a Partition

Partitions are used to group zones that are located in the same area or that are logically connected together. This can represent entire buildings or portions of a building. If you select the same partition in the zones belonging to a specific area, monitoring is done with one partition instead of several zones. Zones in a partition can also be bypassed and activated collectively.

What You Should Know

NOTE: *In order to be available for assignment, a partition must be created.*

1. In edit mode, Under the **General** tab, click on the edit field next to **Partition**.
2. Click in the circle to the left of the partition of your choice.

Figure 11-1 Example of a partition

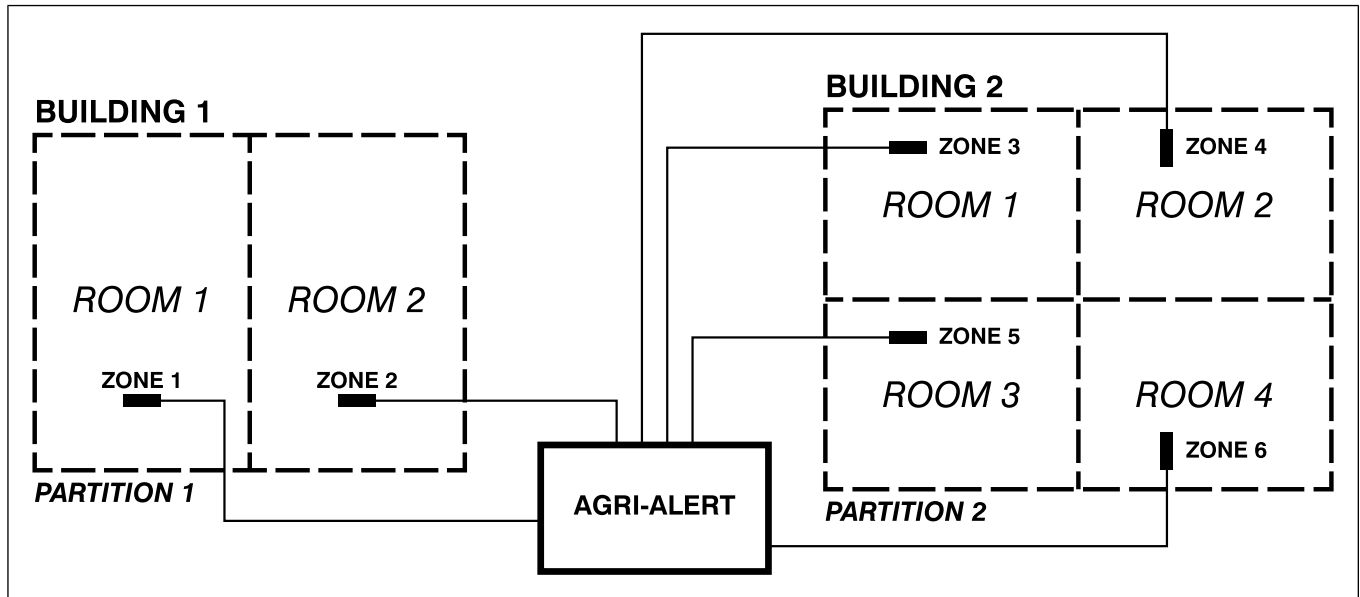

Selecting a Module

By selecting a module you link the zone to the area you want to monitor.

1. In edit mode, under the **General** tab, click on the **Module** edit field to display the selection box.
2. Select a module from the list.

NOTE: Only the modules that are connected to the system and that are initialized in the system are available for selection.

Selecting an Input

1. In edit mode, under the **General** tab, click on the **Input** edit field to display the selection box.
2. Select the input from the list.

Selecting a Zone Type

Selecting a zone type allows the system to properly interpret the data received from the selected input

What You Should Know

IMPORTANT: The selected zone type must correspond to the type of sensor associated with the input you selected.

1. In edit mode, under the **General** tab, click on the **Type** edit field to display the selection box.
2. Select a zone type from the list. Once a zone type has been selected, the configuration page displays the appropriate settings.

NOTE: The outdoor temperature zone type is not available if it has already been assigned to a zone.

Setting the Alert Recognition Time

The alert recognition time is used to calculate the set period of time before an alert condition is recognized and an alert set off. The zone must continuously be in an alert condition for a specific period of time before an alert is recognized and set off.

1. In edit mode, under the **General** tab of the zone you are configuring, click on the edit field next to the **Recognition** button.
2. Set the alert recognition time.

Figure 11-2 Graph displaying an example of an alert with an 8 second recognition time

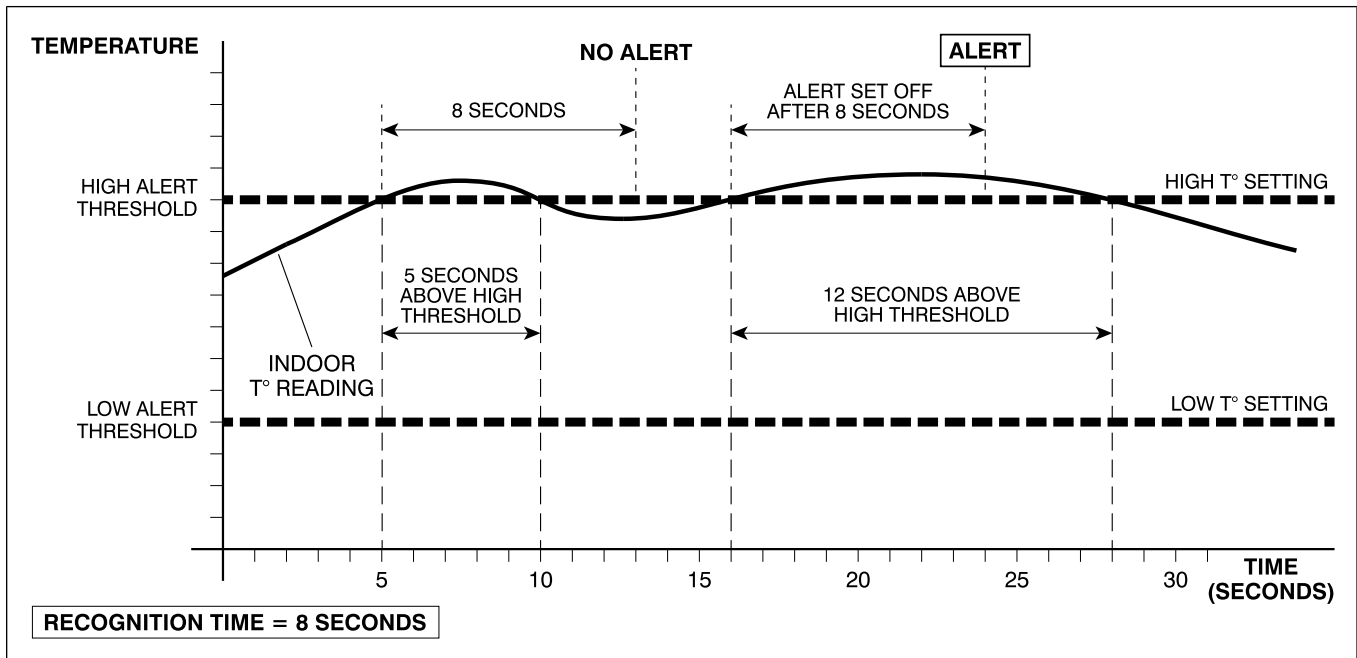

Setting the Alert Recovery Time

The alert recovery time is a set amount of time that a zone must remain within its normal range following an alert before a new alert can be set off.

1. In edit mode, under the **General** tab of the zone you are configuring, click on the edit field next to the **Recovery** button.
2. Set the alert recovery time.

Figure 11-3 Graph showing a zone in an alert state followed by a 10 second recovery time

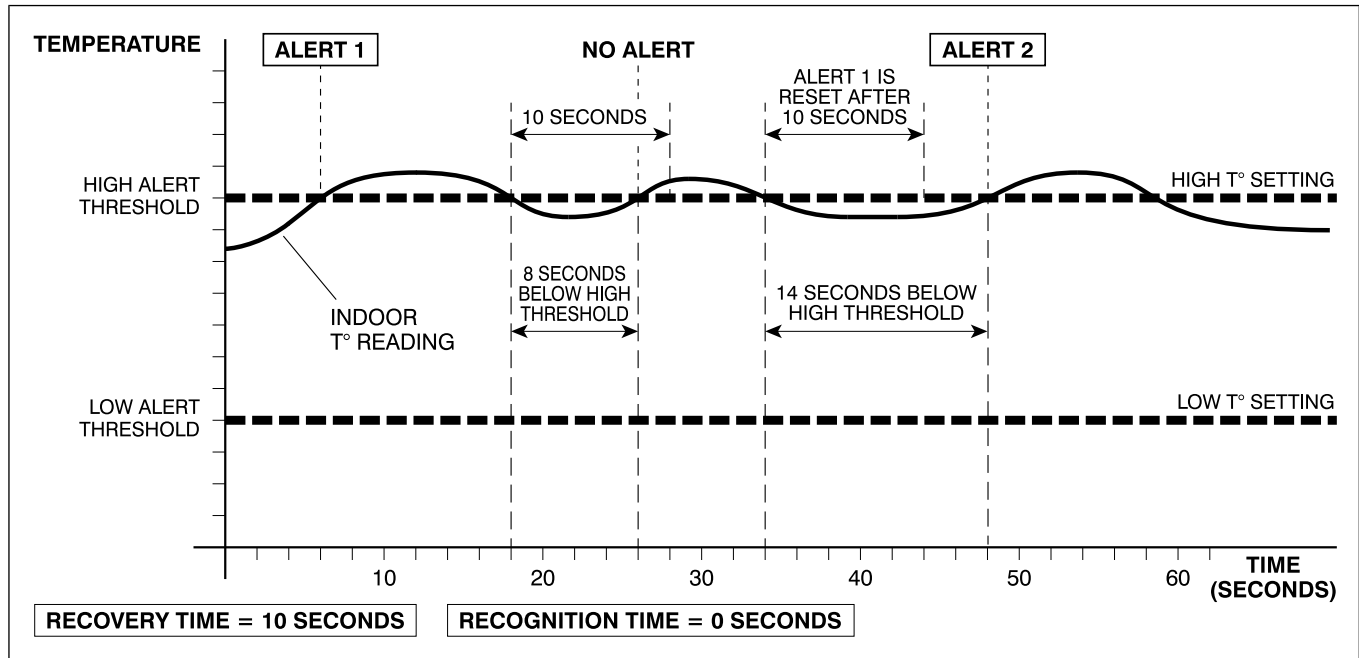

Resetting the Daily Minimum and Maximum

The system monitors and constantly updates the minimum and maximum values reached within a 24 hour period. The time of the recorded minimum and maximum values is displayed. After 24 hours, the values are reset and the monitoring starts anew.

In status mode, under the **General** tab in the zone you are configuring, click on the **Reset min/max**.

The information beside the **Max 24h** and **Min 24h** buttons is reset.

Choosing the Type of End of Line Resistor

When configuring a zone using end of line resistors, you must choose the type of end of line resistors used in your installation for the zone you are configuring to ensure data accuracy.

1. In edit mode, under the **General** tab, click on the edit field next to **EOLR**.
2. Select the type of resistor you are using.

Selecting the Type of Contact in the Dry Contact Zone

1. In edit mode, under the **General** tab, click on the edit field next to the **Contact** button.
2. Select the contact type used for the zone.

Activating a device in the Event of an Alert or Trouble

A device, such as a fan or a heater, can be turned on or off when an alert condition or trouble is detected in a zone. To do so, a programmable output must be activated in the zone.

1. In edit mode, under the **Action** tab, click on the edit field next to the event type you want the device's output linked to.

A list of available outputs is displayed.

NOTE: *Only the previously configured outputs are displayed.*

2. Click in the box to the left of the chosen output.

Receiving a Phone Call When an Alert is Active

In the event of an alert in a zone, the system calls the phone numbers selected to inform key people of the alert state.

What You Should Know

NOTE: *The phone numbers and phone groups must first be entered in the system menu.*

1. In edit mode, under the **Action** tab of the zone you are configuring, click on the edit field next to the telephone icon .
2. Click in the box to the left the contact person or group you would like to be notified in the event of an alert in the given zone.

After You Finish

Make sure to record the message you want your system to play when calling.

Receiving an E-mail When an Alert is Active

When an alert is present in a zone, the system sends the assigned contact group an e-mail to inform them of the situation. Receiving an e-mail when an alert is activated allows you to be alerted even when you are on the phone or out of the country.

Before You Begin

NOTE: *E-mail addresses but first be entered in the **Menu**→**System**→**Contacts** to be available for selection.*

1. In edit mode, under the **Action** tab of the zone you are configuring, click on the edit field next to the e-mail icon .
2. Choose the e-mail addresses to contact from the list.

Enabling the Siren

If you install a siren, you can chose to make it sound or not when an alert is set off in a zone.

Before You Begin

NOTE: *A siren must be installed and connected to your system for this feature to work.*

Chapter 11: Configuring a Dry Contact Zone

In edit mode, under the **Action** tab of the zone you are configuring, click on the edit field next to siren icon .

A check mark indicates the siren is enabled.

Enabling the Internal Speaker

The internal speaker allows you to hear the alert messages from the system when you are near the main system.

In edit mode, under the **Action** tab of the zone you are configuring, click on the edit field next to the speaker icon .

A check mark indicates the internal speaker is enabled.

Recording the Zone Audio Label

The audio label is the name the system repeats to identify the zone when calling because an alert is set off in the zone.

1. In edit mode, under the **Mess.** tab of the zone you are configuring, click on the record icon .



NOTE: *The time remaining to record the audio label starts counting down once you press the record button.*

Tip

For consistency, use the same words as you used when giving the **Name** in the zone's **General** tab.

2. State the zone audio label clearly.

NOTE: *The recording stops when it has reached the allowed time of 8 seconds.*

3. Click on the play icon  to listen to the recording.
4. If the recording is not satisfactory, press the garbage icon  to delete the recording and start over.
5. Repeat steps 2 through 5 to record the zone audio label in another language.

Viewing Zone Calibration

In addition to system diagnostics, you can view the zone calibration in the zone itself.

In status mode, under the **Message** tab, click on the **Calibration** button.

Trouble limits, raw and calibrated data is displayed.

The green LED lights when the **Calibration** button is enabled

Calibrating the Zone Trouble Thresholds

In certain installations, you have to adjust the low or high ohm trouble calibration to avoid constant false trouble alerts.

In edit mode, under the **Calibration** tab, enter the desired value in the edit fields next to **Low ohm trouble** and **High ohm trouble**.

NOTES

12 Configuring an Intrusion Zone

Topics Covered in this Chapter

- Naming the Zone with a Text Label
- Selecting a Module
- Selecting an Input
- Selecting a Zone Type
- Choosing the Type of End of Line Resistor
- Selecting the Type of Contact in the Dry Contact Zone
- Providing Enough Time to Disarm After Entry
- Providing Enough Time to Exit After Arming
- Activating the at Home Arming
- Activating the Chime on an Intrusion Zone Type
- Activating a device in the Event of an Alert or Trouble
- Receiving a Phone Call When an Alert is Active
- Receiving an E-mail When an Alert is Active
- Enabling the Siren
- Enabling the Internal Speaker
- Recording the Zone Audio Label
- Viewing Zone Calibration

Naming the Zone with a Text Label

The zone text label is a name you give to a zone to facilitate its identification. In addition to the zone number, the text label appears everywhere where the zone is identified in writing on the user interface.

1. In edit mode, under the **General** tab of the zone you are configuring, click on the edit field next to the **Name** button.
2. Type in the zone label of your choice.

NOTE: *The field is limited to 32 characters.*

Selecting a Module

By selecting a module you link the zone to the area you want to monitor.

1. In edit mode, under the **General** tab, click on the **Module** edit field to display the selection box.
2. Select a module from the list.

NOTE: *Only the modules that are connected to the system and that are initialized in the system are available for selection.*

Selecting an Input

1. In edit mode, under the **General** tab, click on the **Input** edit field to display the selection box.
2. Select the input from the list.

Selecting a Zone Type

Selecting a zone type allows the system to properly interpret the data received from the selected input

What You Should Know

IMPORTANT: *The selected zone type must correspond to the type of sensor associated with the input you selected.*

1. In edit mode, under the **General** tab, click on the **Type** edit field to display the selection box.
2. Select a zone type from the list. Once a zone type has been selected, the configuration page displays the appropriate settings.

NOTE: *The outdoor temperature zone type is not available if it has already been assigned to a zone.*

Choosing the Type of End of Line Resistor

When configuring a zone using end of line resistors, you must choose the type of end of line resistors used in your installation for the zone you are configuring to ensure data accuracy.

1. In edit mode, under the **General** tab, click on the edit field next to **EOLR**.
2. Select the type of resistor you are using.

Selecting the Type of Contact in the Dry Contact Zone

1. In edit mode, under the **General** tab, click on the edit field next to the **Contact** button.
2. Select the contact type used for the zone.

Providing Enough Time to Disarm After Entry

To avoid an alert being set off when you enter the building, provide enough time to access the system and disarm before an alert is set off.

Before You Begin

Attention

Only the entry zones can have an **Entry delay**. You must click on the **Entry zone** button to make the zone an entry zone to have access to the field.

What You Should Know

NOTE: *Only zones configured as intrusion zones can be disarmed.*

1. In edit mode, under the **General** tab, Click on the edit field next to the **Entry delay** button.
2. Enter the amount of time needed to reach and disarm the system when entering the building.

Providing Enough Time to Exit After Arming

Once you have armed your system, you must have enough time to exit the building without setting off an alert.

Before You Begin

Attention

Only the entry zones can have an **Exit delay**. You must click on the **Entry zone** button to make the zone an entry zone to have access to the field.

What You Should Know

NOTE: *Only zones configured as intrusion type zones can be armed.*

1. In edit mode, under the **General** tab, click in the edit field next to the **Exit delay**.
2. Enter the time needed to exit the building after arming.

Activating the at Home Arming

When your building is equipped with motion detectors, and you would like to arm the windows and doors, you can activate the at home arming.

In edit mode, under the **General** tab, click on the at home arming button.

The green LED lights when the at home arming is enabled.

Activating the Chime on an Intrusion Zone Type

In edit mode, under the **General** tab, click on the box next to the chime icon.

A checkmark indicates that the chime is enabled.

Activating a device in the Event of an Alert or Trouble

A device, such as a fan or a heater, can be turned on or off when an alert condition or trouble is detected in a zone. To do so, a programmable output must be activated in the zone.

1. In edit mode, under the **Action** tab, click on the edit field next to the event type you want the device's output linked to.

A list of available outputs is displayed.

NOTE: *Only the previously configured outputs are displayed.*

2. Click in the box to the left of the chosen output.

Receiving a Phone Call When an Alert is Active

In the event of an alert in a zone, the system calls the phone numbers selected to inform key people of the alert state.

What You Should Know

NOTE: *The phone numbers and phone groups must first be entered in the system menu.*

1. In edit mode, under the **Action** tab of the zone you are configuring, click on the edit field next to the telephone icon .
2. Click in the box to the left the contact person or group you would like to be notified in the event of an alert in the given zone.

After You Finish

Make sure to record the message you want your system to play when calling.

Receiving an E-mail When an Alert is Active

When an alert is present in a zone, the system sends the assigned contact group an e-mail to inform them of the situation. Receiving an e-mail when an alert is activated allows you to be alerted even when you are on the phone or out of the country.

Before You Begin

NOTE: *E-mail addresses must first be entered in the **Menu**→**System**→**Contacts** to be available for selection.*

1. In edit mode, under the **Action** tab of the zone you are configuring, click on the edit field next to the e-mail icon .
2. Choose the e-mail addresses to contact from the list.

Enabling the Siren

If you install a siren, you can choose to make it sound or not when an alert is set off in a zone.

Before You Begin

NOTE: *A siren must be installed and connected to your system for this feature to work.*

In edit mode, under the **Action** tab of the zone you are configuring, click on the edit field next to siren icon .

A check mark indicates the siren is enabled.

Enabling the Internal Speaker

The internal speaker allows you to hear the alert messages from the system when you are near the main system.

In edit mode, under the **Action** tab of the zone you are configuring, click on the edit field next to the speaker icon .

A check mark indicates the internal speaker is enabled.

Recording the Zone Audio Label

The audio label is the name the system repeats to identify the zone when calling because an alert is set off in the zone.

1. In edit mode, under the **Mess.** tab of the zone you are configuring, click on the record icon .



NOTE: *The time remaining to record the audio label starts counting down once you press the record button.*

Tip

For consistency, use the same words as you used when giving the **Name** in the zone's **General** tab.

2. State the zone audio label clearly.

NOTE: *The recording stops when it has reached the allowed time of 8 seconds.*

3. Click on the play icon  to listen to the recording.
4. If the recording is not satisfactory, press the garbage icon  to delete the recording and start over.
5. Repeat steps 2 through 5 to record the zone audio label in another language.

Viewing Zone Calibration

In addition to system diagnostics, you can view the zone calibration in the zone itself.

In status mode, under the **Message** tab, click on the **Calibration** button.

Trouble limits, raw and calibrated data is displayed.

The green LED lights when the **Calibration** button is enabled

NOTES

13 Maintenance

Topics Covered in this Chapter

- Inspecting and Cleaning the Controller
- Replacement Fuse Specifications
- Replacing a Fuse
- Replacing the Battery

Inspecting and Cleaning the Controller

Inspecting the controller and its units and keeping them clean can help prolong the proper functioning of the controller.

Before You Begin



Disconnect supply before servicing or performing any maintenance operations.



Unplug the phone cord while installing or servicing the phone card.



Lock the enclosure once the wiring is completed or when servicing. Use the included nut and bolt or a padlock (not included) to lock the enclosure.

- Once a year, open and inspect the enclosures for moisture or dust build-up.
- Using a damp cloth, wipe clean the exterior of the enclosures.



Do not spray water on the controller or on any of its modules.

Replacement Fuse Specifications

Replacement fuses are supplied with your system if ever the need occurs to change them. Two of each model are available.

GSI Electronics part number	GSI Electronics part description	Reference	Fuse recommended by the manufacturer	Recommended fuse model
127-00031	Fuse 2.5A slowblow 5X20MM 250V	F27- F28	Bel Fuse	5HT 2.5-R
127-00032	Fuse 1A slowblow 5X20MM 250V	F29- F30	Bel Fuse	5HT 1-R

127-00033	Fuse 500MA slowblow 5X20MM 250V	F31- F32	Bel Fuse	5HT 500-R
127-00034	Fuse 2A slowblow 5X20MM 250V	F33- F34	Bel Fuse	5HT 2-R

Replacing a Fuse

Before You Begin

Only service personnel is authorized to replace a fuse.



Before servicing the system, disconnect the main sector voltage and disconnect the battery wires from the battery.



Wear appropriate grounding devices such as an anti-static wristband to service the system.

1. Open the circuit of the main sector voltage.
2. Disconnect the red wire from the positive battery terminal.
3. Isolate the source of the fault and correct it.
4. Install the red wire to the positive battery terminal if the replacement is completed.
5. Close the circuit of the main sector voltage.

Replacing the Battery

At some point the battery will need to be changed. Properly doing so ensures the system functions properly.

Before You Begin



Installation must only be performed by qualified service personnel. Comply with local and national safety codes.

1. Open the circuit of the main sector voltage
2. Disconnect the red wire from the positive battery terminal.
3. Disconnect the black wire from the negative battery terminal.
4. Remove the battery from the battery box
5. Install the new battery in the battery box. Ensure that the new battery is fastened correctly in the battery box.
6. Install the black wire to the negative battery terminal.
7. Install the red wire to the positive battery terminal.
8. Close the circuit of the main sector voltage to reactivate the controller.

14 Tests

Topics Covered in this Chapter

- Testing the System
- Testing Communication With the Contacts

Testing the System

The system can continuously test the system's hardware and communication in sequence.

Before You Begin

NOTE: *You can click on the item's button to test a single field.*

1. Click on **Menu**→**Test**.
2. Click on **Start auto test** to start testing all tabs sequentially.
A list of the ongoing tests are displayed on the right hand side of the page.
3. Click on **Stop auto test** to end the testing.

Testing Communication With the Contacts

Testing communication methods with the contacts ensures the messages reach the contacts in the event of an alert.

Before You Begin

NOTE: *The chosen contacts receive a message from the system informing them of the test.*

1. Click on **Menu**→**Test**.
2. In edit mode, under the **General** tab, select a contact for the phone test, one for the e-mail test, and one for the SMS test.
3. Click on **Start auto test** to start the testing of all tests that are configured.
A list of the ongoing tests are displayed on the right hand side of the page.
4. Click on **Stop auto test** to end the testing.

NOTES

15 Troubleshooting

The 28 volt auxiliary is disconnected	Make sure the 28VDC does not exceed the circuit capacity.
	Check the main sector to the AA128 Touch and wiring.
	Check if the fuse F31 or F32 is not opened.
	Use a voltmeter to check voltage at the AA128 Touch supply input terminals (24Vdc minimum at J13 between VDC+ and VDC-).
	If the problem persists, contact your dealer.
The 12 volt auxiliary is disconnected	Make sure the load connected to the 12VDC output does not exceed the circuit capacity.
	Check the wiring of the 12VDC output.
	Check if the fuse F29 or F30 is not opened.
	If the problem persists, contact your dealer.
The SBI power is disconnected	Make sure the SBI power output and siren do not exceed the circuit capacity.
	Check the main sector to the AA128 Touch and wiring.
	Check if the fuse F27 or F28 is not opened.
	Use a voltmeter to check voltage at the AA128 Touch supply input terminals (24Vdc minimum at J13 between VDC+ and VDC-).
	If the problem persists, contact your dealer.
The siren output is disconnected	Make sure the load connected to the siren output does not exceed the circuit capacity.
	Check the wiring of the siren output.
	Check if the fuse F33 or F34 is not opened.
	If the problem persists, contact your dealer.
The Low battery icon is displayed and electrical power is functioning	Check the main sector to the AA128 Touch and wiring.
	Use a voltmeter to check voltage at the AA128 Touch supply input terminals (24Vdc minimum at J13 between VDC+ and VDC-).
	Check the battery wiring.
	Use a voltmeter to check voltage at the battery terminal (battery at full load: between 12 and 13 V).
	If the problem persists, contact your dealer.
The recharge is suspended	That is not a problem. The system automatically stops charging the battery when the battery's temperature gets too high.
The No battery icon is displayed	Make sure a battery is connected to the controller.

Chapter 15: Troubleshooting

The disconnected line icon is displayed	Make sure the entry line is plugged in the right phone jack of the phone plug-in card.
	Make sure the plug-in card is properly inserted in the "PHONE CARD" connector.
	If the problem persists, unplug the telephone jack from the phone plug-in card and contact you dealer.
The phone card disconnected icon is displayed	Make sure the plug-in card is properly inserted in the "PHONE CARD" connector.
	Check the phone line wiring.
	If the problem persists, unplug the phone card and contact your dealer.
The siren doesn't work	Make sure the siren load does not exceed the circuit capacity.
	If no siren is connected to the siren terminals, a resistor must be connected in its place (1.5k Ω , 1/2 W) or you can disable the siren output .
	If the siren impedance is too high, add a 1,5K Ω , 1/2W resistor to the siren circuit, as close to the siren as possible.
	The siren wire or the siren may be defective.
	If the problem persists, contact your dealer.
I plugged the battery into the controller and it doesn't start	On first startup, the controller needs to be powered by the main sector.
The system does not detect any probe	Make sure the flat cable between the top and the bottom board inside the enclosure is properly connected.
	Make sure the removable terminal block is properly inserted on the bottom board.
	Check the wiring of the zone inputs.
	If the problem persists, contact your dealer.
The system shuts down as soon as I unplug the main sector	Make sure the battery is correctly connected.
	Let the system recharge the battery for about 3 hours and a half.
	Make sure the loads connected to the siren output, 12VDC output, 28 VDC output, SBI power output do not exceed the circuit capacity.
	If the problem persists, contact your dealer.
The system refuses to arm	Make sure a intrusion zone is programmed.
	Make sure there is no active alarm in any intrusion zone.
	Login with the installer or master password.
	If the problem persists, contact your dealer.

Phone communication troubles

Problem	Cause	Solution
I cannot change the relay status on the phone	The relay is assigned to a zone	When a relay is assigned to a zone, it is not possible to change its status on the phone (the relay status is related to the zone status).

I cannot stop the on-site listening on the phone	This is normal	The On-Site listening automatically ends after a user-defined delay (On- Site Listening delay); it cannot end sooner.
The system cannot recognize my password or selection over the phone	Phone compatibility	If the AA128 Touch does not recognize your selection, try typing your choice slower (leave about 1/2 seconds between each key).

NOTES

A List of Terminals in the Main Enclosure and Battery Enclosure

Each module, input, or output has its place on the system board. To ensure no false alerts or trouble occur, connect all modules, inputs and outputs in the correct area.

Table A-1 Main enclosure terminals and usage

Terminal	Terminal Board	Description
ZONE1		Sensor input terminals numbered 1 through 8. Each input has its own return (AGND).
AGND1-2		
ZONE2		
ZONE3		
AGND3-4		
ZONE4		
ZONE5		
AGND5-6		
ZONE6		
ZONE7		
AGND7-8		
ZONE8		
EXT. MIC +		
EXT. MIC -		
EXT. MIC SHIELD		
SBI +		Serial bus interface communication bus. Wired between the main system and optional expansion modules. Each module has the same four terminals. The same terminals are wired to each other between all modules.
SBI COMM A		
SBI COMM B		
SBI -		
PVX COMM A		PVX communication bus.
PVX COMM B		
GND		
12 VDC +		12 VDC power output for external sensors. Maximum 750 mA.
12 VDC -		
AUX. SUPPLY +		28 VDC power output for external sensors. Maximum 350 mA.
AUX. SUPPLY -		
SIREN +		Outputs to connect a siren.
SIREN -		

Appendix A: List of Terminals in the Main Enclosure and Battery Enclosure

Table A-1 Main enclosure terminals and usage (cont'd.)

Terminal	Terminal Board	Description
RELAY 1 NO		Relay 1 output. You can select from a normally open or a normally closed contact.
RELAY 1 COM		
RELAY 1 NC		
RELAY 2 NO		Relay 2 output. You can select from a normally open or a normally closed contact.
RELAY 2 COM		
RELAY 2 NC		
EARTH		
TEMP_BATT +		Battery temperature probe connections (through power cable from power pack).
TEMP_BATT –		
BATT +		Battery power supply inputs (through power cable from power pack).
BATT –		
VDC +		Line power supply inputs (through power cable from power pack).
VDC –		
TIP (LINE)		Phone connection for alert communications.
RING (LINE)		
TIP (PHONE)		
RING (PHONE)		

Table A-2 Battery enclosure terminals

Terminal	Terminal Board	Description
L1		Line supply inputs (120 V, 60 Hz).
L2/N		
EARTH		
VDC +		Main power supply outputs (through power cable to control module).
VDC –		
BATT +		Battery power supply outputs (through power cable to control module).
BATT –		
BATT TEMP +		Battery temperature probe outputs (through power cable to control module).
BATT TEMP –		

B Battery Wire Specifications

Use twisted pair wires and shielded wires.

Item	Description
Certification and type	CSA, CMG FT4 type, 20 AWG, 600 V, 75 °C (167 °F)
	UL, AWM or CM ttype, 20 AWG, 600 V, 75 °C (167 °F)
Maximum length	36 inches

Wire specifications for battery connections to the power supply

Item	Description
Certification and type	CSA, TEW type, 10 AWG, 600 V, 105 °C (221 °F)
	UL, 1015 type, 10 AWG, 600 V, 105 °C (221 °F)
Maximum length	36 inches

NOTES

C Low Voltage Cable Specifications

Using the correct cables when installing your system ensures maximum performance.

The following requirements apply to the following low voltage devices unless otherwise stated:

- Sensor cables
- Potentiometer cables
- Communication cables
- All other low voltage devices

Table C-1 *Low voltage cable specifications*

Item	Description
Cable type	Twisted and shielded
Minimum gauge	1 mm ² (18 AWG)
Maximum sensor cable length (including any cable extension)	150 m (500 feet)

When extending a cable (see figure below):

- solder all joints (2)
- use heat shrink tubing
- do not connect ground wire, cut it (1)

Figure C-1 *Soldering the joints when extending a cable*

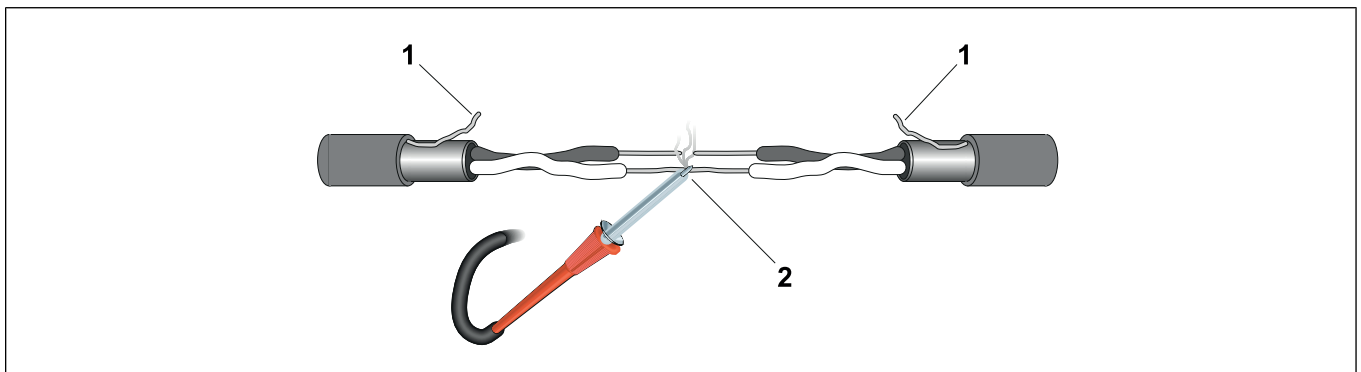

NOTES

D Technical Specifications

TYPE: Agri-Alert system

Operating Temperature: 32 to 104°F (0 to 40°C)

Indoor use only

Pollution Degree: 2

Installation Category: 2

Altitude: 7900 Ft. Max (2000 Meters Max)

Humidity (maximum relative) operating:

- 0 to 10 °C (32 to 50 °F) Non condensing
- 10 to 30 °C (50 to 86 °F) 95 % (± 3 %) Non condensing
- 30 to 40 °C (86 to 104 °F) 95 % (± 3 %) Non condensing

SUPPLY INPUT :

100V_{AC}-240V_{AC}, 1 phase, 240W, 50-60Hz

BATTERY: Rechargeable, sealed, lead-acid, 12V-7.0AH

OUTPUTS :

RELAY 1-2: 28Vdc, 4A max.

SERIAL BUS: 28Vdc, 2A max.

SIREN: 12Vdc, 1.5A max.

12VDC: 12Vdc, 750mA max.

28VDC : 28Vdc, 350mA max.

Main supply voltage fluctuations shall not exceed +/- 10% of the nominal supply voltage.

Table D-1 Main enclosure specifications

Item	Description	
Enclosure material	Flame retardant ABS	
Dimensions	Width	11 inches (28 cm)
	Height	9-7/8 inches (25 cm)
	Depth	5 inches (12.7 cm)
	Weight	5.15 kilograms (11.35 lbs)
Sensor inputs	8 inputs, self-configuring for various sensor types	
Touch screen	Size	7 inches (17.8 cm)
	Type	TFT color LCD
	Resolution	WVGA (800 × 480 pixels)

Appendix D: Technical Specifications

Table D-2 *Battery enclosure specifications*

Item	Description		
Enclosure material	Flame retardant ABS		
Dimensions	Width	11 inches (28 cm)	
	Height	9-7/8 inches (25 cm)	
	Depth	5 inches (12.7 cm)	
Weight	2.97 kilograms (6.55 lbs) including the weight of the battery		
Nominal voltage	12 Volts		
Nominal capacity	7.00 Ah		
Terminal	T2 (Faston Tab 250)		
Storage temperature	-20 °C to 40 °C (-4 °F to 104 °C)		
Battery (the values shown are based on ambient temperatures of 20 - 25 °C (68 - 77 °F))	Type	Sealed lead-acid battery	
	Power output	12 VDC, 7.5 Ah	
	Shelf discharge	3% per month	
	Average battery capacity with low load	When the siren, the 12 VDC outputs and the SBI are not used.	32 hours
	Average battery capacity with high load	When the siren, the 12 VDC outputs and the SBI are used.	20 minutes
	Average lifespan	3 years	
	Battery weight	2.2 kilograms (4.85 lbs)	

E Replacement Fuse Specifications

Replacement fuses are supplied with your system if ever the need occurs to change them. Two of each model are available.

GSI Electronics part number	GSI Electronics part description	Reference	Fuse recommended by the manufacturer	Recommended fuse model
127-00031	Fuse 2.5A slowblow 5X20MM 250V	F27- F28	Bel Fuse	5HT 2.5-R
127-00032	Fuse 1A slowblow 5X20MM 250V	F29- F30	Bel Fuse	5HT 1-R
127-00033	Fuse 500MA slowblow 5X20MM 250V	F31- F32	Bel Fuse	5HT 500-R
127-00034	Fuse 2A slowblow 5X20MM 250V	F33- F34	Bel Fuse	5HT 2-R

NOTES

F Wiring Diagram with Terminals

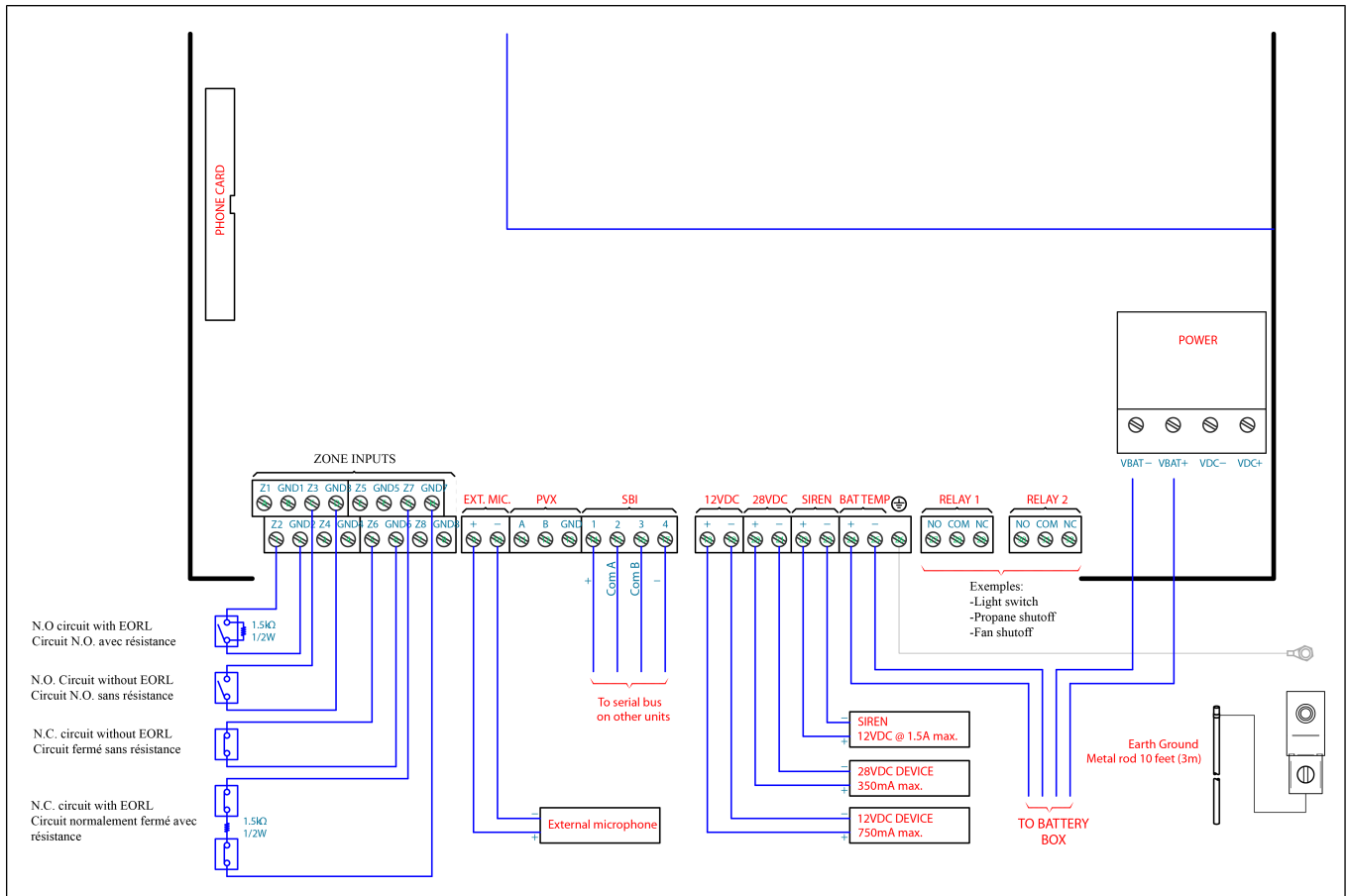

Appendix F: Wiring Diagram with Terminals

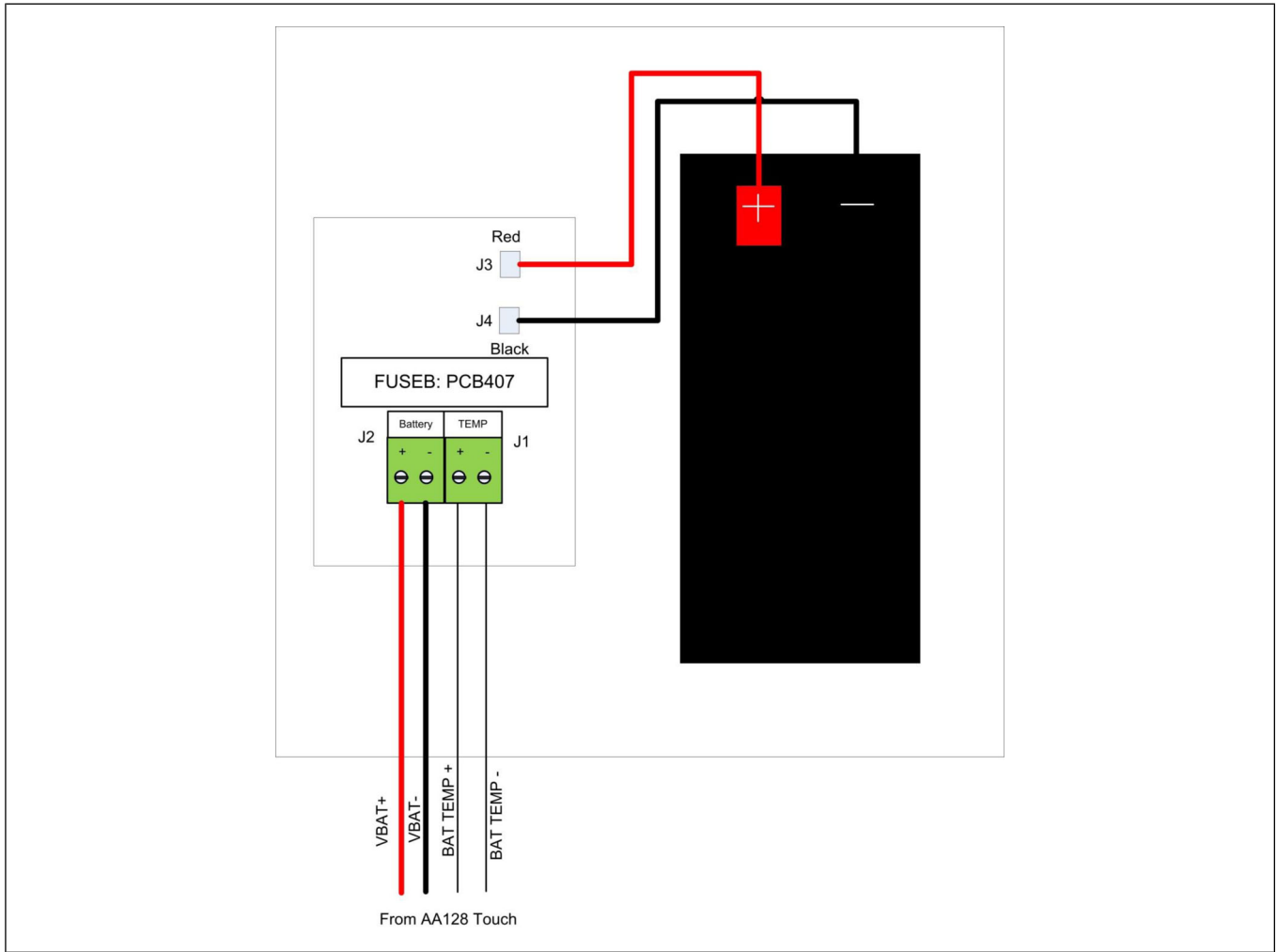

Wiring diagram with a DPST disconnect switch

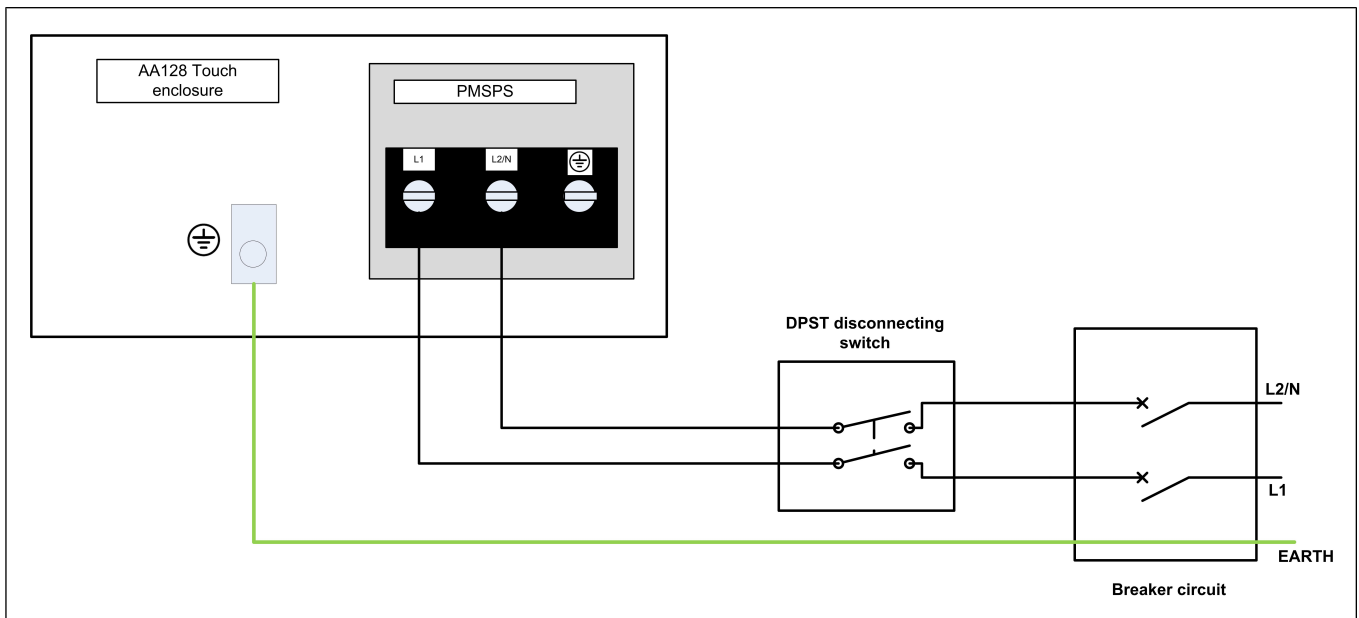

Wiring diagram with a SPST disconnect switch

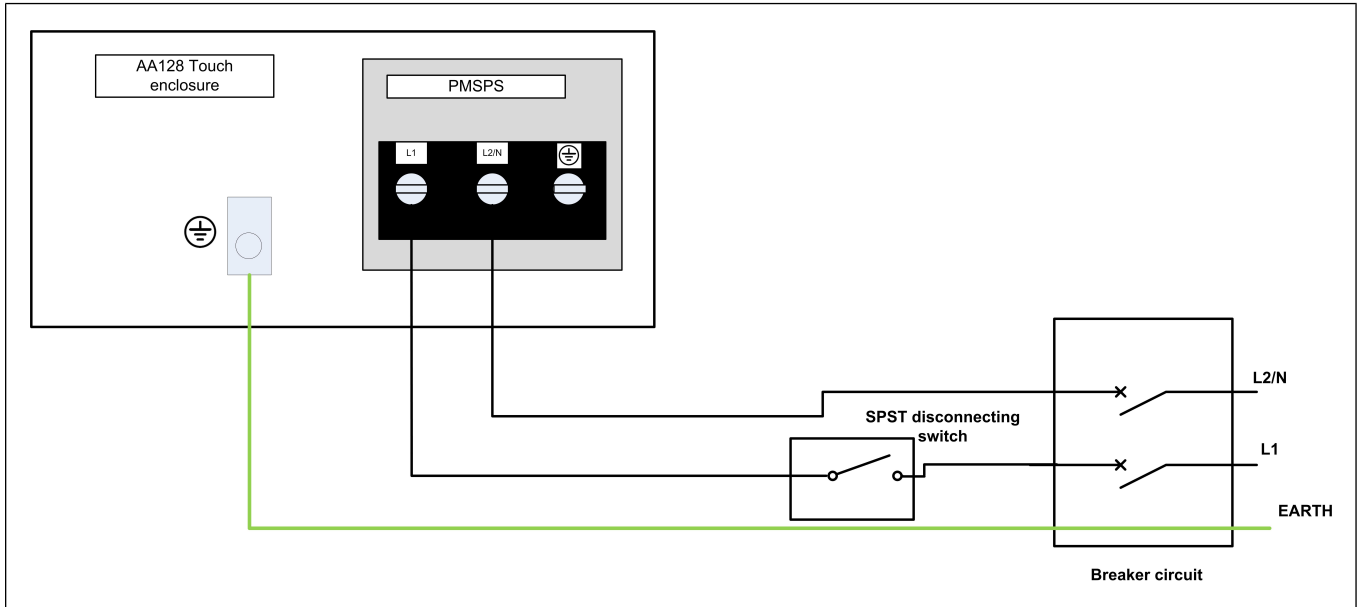

NOTES

G Safety Characteristics and Certification

This controller is Safety Class I according to IEC classification and has been designed to meet the requirements of UL 61010-1 third edition and CAN/CSA-C22.2 n° 61010-1 third edition (Safety Requirements for Electrical Equipment for Measurement, Control and Laboratory Use). It is an Installation Category II intended for operation from a normal single phase supply.

This controller has been tested in accordance with IEC61010-1 and has been supplied in a safe condition. This instruction manual contains some information and warnings which have to be followed by the user to ensure safe operation and to retain the instrument in a safe condition.

Emission standards

This controller has been designed to meet the requirements of the EMC Directive 2004/108/EC. The compliance was demonstrated by meeting the test limits of the following standards:

Test number	Test name	Standard	Standard level
1	Conducted emissions	CISPR 11 : 2009 A1 (2010) FCC part 15, under part B : 2012	Group 1, class A Class A
2	Radiated emissions	CISPR 11 : 2009 A1 (2010) FCC part 15, under part B : 2012	Group 1, class A Class A
3	Harmonic current emissions	IEC61000-3-2: 2006 A1 (2009) A2 (2009)	Class A
4	Flickers limitation	IEC61000-3-3: 2008	≤4% on the main sector voltage envelope

Immunity standards

EN61326-1 (2013) EMC product standard for Electrical Equipment for Measurement, Control and Laboratory Use and FCC part 15. Test methods, limits and performance achieved are shown below (requirement shown in brackets):

Test number	Test name	Standard	Standard level
5	Radiated, radio-frequency, electromagnetic field immunity test	EN61000-4-3 : 2006 A1 : 2007 A2 : 2010	80% AM at 1kHz, 10V/m, 80MHz – 1GHz: Performance: A (A) 80% AM at 1kHz, 3V/m, 2GHz to 2.7GHz:
6	Immunity to conducted disturbances, induced by radio-frequency fields	EN61000-4-6 : 2008	150kHz-80MHz : 3Vrms + 1kHz 80% AM (AC line, Earth, I/O connections >3m)
7	Electrostatic discharge immunity test	EN61000-4-2 : 2008	± 8 kV air ± 4 kV contact Performance A (B)
8	Electrical fast transient/ burst immunity test	EN 61000-4-4 : 2012	±2kV/5kHz on the main sector ±1kV/5kHz on the I/O >3m Performance A (B)

Appendix G: Safety Characteristics and Certification

9	Surge immunity test	EN61000-4-5 : 2005	On the main sector : L-PE : $\pm 2\text{kV}$ L-L : $\pm 1\text{kV}$ I/O : L-PE : $\pm 1\text{kV}$ L-L : $\pm 1\text{kV}$
10	Power frequency magnetic field immunity test	EN 61000-4-8 : 2009	30 A/m
11	Voltage dips, short interruptions and voltage variations immunity tests	EN61000-4-11 : 2004	0%, 1, 1 cycle: Performance A (B) 40%, 1, 10 cycles: Performance A (C) 70%, 1, 25 cycles: Performance A (C) 0%, 1, 250 cycles: Performance A (C)

According to EN61326-1 the definitions of performance criteria are as follows:

- Performance criterion A — During test normal performance within the specification limits
- Performance criterion B — During test, temporary degradation, or loss of function or performance which is self-recovering
- Performance criterion C — During test, temporary degradation, or loss of function or performance which requires operator intervention or system reset occurs.

Phone circuit safety characteristics

The phone card is designed and tested to meet the following requirements:

- UL 60950-1 second edition and CAN/CSA-C22.2 no 60950-1 second edition in the section 6.
- NSI/TIA-968-B (Telecommunications, Telephone Terminal Equipment, Technical Requirements for Connection of Terminal Equipment to the Telephone Network, Approved: August 11, 2009 TIA-968-B-1 Addendum 1, June 2012).
- FCC standard Part 68 (FCC rules for Registration of Telephone Equipment).
- CS-03 Part I (Issue 9 Amendment 4, December 2010, requirements for terminal equipment and related access arrangements intended for direct connection to analogue wireline facilities).

The phone card, model PCB402 (300-00319), the ACTA number is US:32ZCN01BGSIE0001. The phone card, model PCB402 (300-00319), the IC number is IC: 11880A-PCB402RP002.

Environmental characteristics

Parameter	Condition	Value
Temperature Operating	battery installed	0 to 40 °C (32 to 104 °F)
	Storage	-20 to +60 °C (-4 to +140 °F)
Humidity (Maximum Relative) Operating	0 to 10 °C (32 to 50 °F)	Non condensing
	10 to 30 °C (50 to 86 °F)	95 % ($\pm 3\%$) Non condensing
	30 to 40 °C (86 to 104 °F)	95 % ($\pm 3\%$) Non condensing
	Storage	Non condensing
Altitude		7900 Ft. Max (2000 Meters Max)
Electromagnetic Environment		EN/IEC61326-1
Enclosure Protection		IP51, ref : IEC60529
Impact rating (IK)		08

Index

A

access level	
contacts	35
access levels	
types	35
acknowledging an alert	31
action history	
contacts	37
activation	
modules	40
alert	
acknowledging	31
alert communication	
e-mail	54, 61, 71, 79, 86
arming	
automatically	39
at home arming	85
audio label	
recording	55, 62, 72, 80, 87

B

backlight	
adjustment of settings	39
battery	
connections	26
installation	26
battery enclosure	
connecting	27
battery temperature sensor	
connecting	28
battery, backup	
connecting	27
bypassing a zone	32

C

cables	
cable support and routing	16
calibration	
sensor outputs	62, 72
temperature probe	56
trouble	
calibration	81
zone	81
calibration zero	
calibration span	
how it works	63, 73
how it works	63, 73
call out sequence	

phone settings	41
carrier wait time	42
chime	85
cleaning the controller	89
communication	
testing	91
configuration	78, 84
calibration zero	
calibration span	
setting the calibration zero	63, 73
zone	45
4 - 20 mA	
minimum and maximum values	60, 70
unit selection	60, 70
alert communications	
phone calls	54, 61, 71, 79, 85
alert recognition time	49, 59, 69, 77
alert recovery time	49, 59, 69, 77
dry contact	78, 84
input (sensor) selection	48, 58, 68, 76, 84
module selection	48, 58, 68, 76, 83
partition selection	47, 57, 67, 75
temperature	
outdoor temperature compensation	52
temperature curve	50
zone type selection	48, 58, 68, 76, 84
connecting	
modules to SBI	29
connecting the equipment	
external microphone	29
siren	26
connections	
phone line	23
contact groups	
creation	
management	36
contacts	
creation	36
management	36
creation	
contact groups	36
contacts	36
partitions	36
critical temperature	
setting the threshold	51

D

date and time	
setting	

Index

- display format..... 33
- DC impedance 42
- deleting information
 - deleting contact groups 32
 - deleting contacts 32
 - deleting temperature curves
 - deleting zones..... 32
- diagnostic
 - viewing..... 33
- diagnostics
 - zone.....62, 74, 80, 87
- disarming
 - automatically 39
- dry contact zone.....78, 84
- DTMF
 - tone duration
 - LF power level
 - HF power level 42
- E**
- e-mail
 - alert communication54, 61, 71, 79, 86
- edit mode 33
- entry delay
 - disarm..... 84
- exit delay
 - arm 85
- F**
- filtering
 - zones 32
- fuse
 - replacement..... 90
 - specifications..... 89, 105
- G**
- gain
 - receiver..... 42
 - transmit..... 42
- grounding the system..... 18
- H**
- hardware
 - testing..... 91
- high and low settings..... 51
- how it works
 - outdoor temperature compensation 52
- I**
- industry canada..... 9
- initializationmodules
 - managing..... 40
 - modules..... 40
- input (sensor) selection48, 58, 68, 76, 84
- inspecting the controller 89
- installation requirements
 - sensor cabling 101
- intruder zones
 - arming..... 31
 - disarming..... 31
- L**
- language selection
 - user interface..... 33
- localization guidelines 15
- logging in..... 32
- login information
 - entering..... 32
- M**
- main system
 - terminals..... 97
- maintenance
 - general..... 89
- microphone
 - activation 42
 - connecting..... 29
- minimum on-hook time 42
- modules
 - initialization..... 40
- mounting the enclosures 25
- O**
- outdoor temperature compensation 52
- output
 - specifications..... 22
- output activation on alert.....53, 60, 71, 79, 85
- outputs
 - configuration..... 41
 - resetting
 - viewing..... 43
- P**
- partition selection47, 57, 67, 75
- partitions





- creation
 - management..... 36
 - phone call alert message54, 61, 71, 79, 85
 - phone groups 36
 - phone line
 - connection possibilities..... 23
 - phone settings
 - call out sequence..... 41
 - technical 42
 - Power source
 - management 37
 - preparing for installation..... 21
 - probe
 - calibration 56
 - programmable outputs
 - configuration
 - programmable outputs..... 41
- R**
- recognition time49, 59, 69, 77
 - trouble..... 43
 - recording system name
 - message
 - trouble..... 42
 - trouble..... 42
 - recovery time.....49, 59, 69, 77
 - trouble..... 43
 - relay output
 - specifications..... 22
 - remote listening
 - microphone..... 42
 - replacement
 - battery..... 90
 - reset
 - daily minimum and maximum.....55, 59, 70, 78
 - reset time55, 59, 70, 78
 - ringer threshold 42
- S**
- SBI
 - connecting the modules 29
 - scale..... 33
 - screen
 - automatic scroll..... 39
 - selecting, units of measure60, 70
 - sensor
 - connecting 28
 - sensor cabling
 - installation requirements 101
 - silence detection 42
- siren
 - connecting 26
 - enabling.....54, 61, 71, 79, 86
 - software
 - updating
 - management..... 37
 - speaker
 - enabling.....55, 62, 72, 80, 86
 - special tools and supplies 15
 - system
 - testing..... 91
 - system overview..... 7
- T**
- technical specifications 103
 - telecommunication information 9
 - temperature
 - scale 33
 - temperature curve
 - creation
 - management..... 37
 - temperature curves..... 37
 - temperature probe
 - calibration 56
 - temperature threshold..... 51
 - temperature zone
 - activation temperature curve 50
 - outdoor temperature compensation 52
 - testing
 - communication with contacts 91
 - system
 - hardware
 - communication..... 91
 - text label.....47, 57, 67, 75, 83
 - time and date
 - setting
 - display format..... 33
 - tip-ring voltage..... 42
 - tools..... 15
 - type of contact.....78, 84
- U**
- user interface
 - language selection 33
- V**
- viewing alert history..... 33

Index

Z

zone audio name.....	55, 62, 72, 80, 87
zone name	47, 57, 67, 75, 83
zone settings	45
zone type selection	45, 48, 58, 68, 76, 84
zones	
filtering.....	32

Certification logos and Definition

 MH19884	Electrical safety approval in North America of the sealed lead-acid battery
 C US	Electrical safety approval of the product in North America : Canada and USA
	European conformity
	Recycling information
	

GSI Group, LLC Limited Warranty

The GSI Group, LLC (“GSI”) warrants products which it manufactures to be free of defects in materials and workmanship under normal usage and conditions for a period of 12 months after sale to the original end-user or if a foreign sale, 14 months from arrival at port of discharge, whichever is earlier. The end-user’s sole remedy (and GSI’s only obligation) is to repair or replace, at GSI’s option and expense, products that in GSI’s judgment, contain a material defect in materials or workmanship. Expenses incurred by or on behalf of the end-user without prior written authorization from the GSI Warranty Group shall be the sole responsibility of the end-user.

Warranty Extensions: The Limited Warranty period is extended for the following products:

	Product	Warranty Period
AP Fans and Flooring	Performer Series Direct Drive Fan Motor	3 Years
	All Fiberglass Housings	Lifetime
	All Fiberglass Propellers	Lifetime
AP/Cumberland	Flex-Flo/Pan Feeding System Motors	2 Years
Cumberland Feeding/Watering Systems	Feeder System Pan Assemblies	5 Years **
	Feed Tubes (1-3/4" and 2.00")	10 Years *
	Centerless Augers	10 Years *
	Watering Nipples	10 Years *
Grain Systems	Grain Bin Structural Design	5 Years
Grain Systems Farm Fans Zimmerman	Portable and Tower Dryers	2 Years
	Portable and Tower Dryer Frames and Internal Infrastructure †	5 Years

* Warranty prorated from list price:
 0 to 3 years - no cost to end-user
 3 to 5 years - end-user pays 25%
 5 to 7 years - end-user pays 50%
 7 to 10 years - end-user pays 75%

** Warranty prorated from list price:
 0 to 3 years - no cost to end-user
 3 to 5 years - end-user pays 50%

† Motors, burner components and moving parts not included.
 Portable dryer screens included.
 Tower dryer screens not included.

GSI further warrants that the portable and tower dryer frame and basket, excluding all auger and auger drive components, shall be free from defects in materials for a period of time beginning on the twelfth (12th) month from the date of purchase and continuing until the sixtieth (60th) month from the date of purchase (extended warranty period). During the extended warranty period, GSI will replace the frame or basket components that prove to be defective under normal conditions of use without charge, excluding the labor, transportation, and/or shipping costs incurred in the performance of this extended warranty.

Conditions and Limitations:

THERE ARE NO WARRANTIES THAT EXTEND BEYOND THE LIMITED WARRANTY DESCRIPTION SET FORTH ABOVE. SPECIFICALLY, GSI MAKES NO FURTHER WARRANTY OF ANY KIND, EXPRESS OR IMPLIED, INCLUDING, WITHOUT LIMITATION, WARRANTIES OF MERCHANTABILITY OR FITNESS FOR A PARTICULAR PURPOSE OR USE IN CONNECTION WITH: (I) PRODUCT MANUFACTURED OR SOLD BY GSI OR (II) ANY ADVICE, INSTRUCTION, RECOMMENDATION OR SUGGESTION PROVIDED BY AN AGENT, REPRESENTATIVE OR EMPLOYEE OF GSI REGARDING OR RELATED TO THE CONFIGURATION, INSTALLATION, LAYOUT, SUITABILITY FOR A PARTICULAR PURPOSE, OR DESIGN OF SUCH PRODUCTS.

GSI shall not be liable for any direct, indirect, incidental or consequential damages, including, without limitation, loss of anticipated profits or benefits. The sole and exclusive remedy is set forth in the Limited Warranty, which shall not exceed the amount paid for the product purchased. This warranty is not transferable and applies only to the original end-user. GSI shall have no obligation or responsibility for any representations or warranties made by or on behalf of any dealer, agent or distributor.

GSI assumes no responsibility for claims resulting from construction defects or unauthorized modifications to products which it manufactured. Modifications to products not specifically delineated in the manual accompanying the equipment at initial sale will void the Limited Warranty.

This Limited Warranty shall not extend to products or parts which have been damaged by negligent use, misuse, alteration, accident or which have been improperly/inadequately maintained. This Limited Warranty extends solely to products manufactured by GSI.

Prior to installation, the end-user has the responsibility to comply with federal, state and local codes which apply to the location and installation of products manufactured or sold by GSI.

9101239_1_CR_rev8.xml (revised January 2014)

This equipment shall be installed in accordance with the current installation codes and applicable regulations which should be carefully followed in all cases. Authorities having jurisdiction should be consulted before installations are made.

AgriAlert

1004 E. Illinois St.
Assumption, IL 62510-0020
Phone: 1-217-226-4421
Fax: 1-217-226-4420
www.gsiag.com



Agri-Alert is a brand of GSI, a worldwide brand of AGCO Corporation.