

# Installation manual

## Green JET Fertigation System



## Green JET

An Integrated Fertigation System

Ag/MIS/ImEN-2749-12/19 Rev 1.5

P/N:116800



# Green JET Fertigation System

Rev 1.5, 12/2022

This document is destined for the user of the apparatus: it may not be reproduced in whole or in part, committed to computer memory as a file or delivered to third parties without the prior authorization of the assembler of the system.

Munters reserves the right to effect modifications to the apparatus in accordance with technical and legal developments.

# Index

| <i>chapter</i> |                                                         | <i>page</i> |
|----------------|---------------------------------------------------------|-------------|
| <b>1</b>       | <b>INTRODUCTION</b>                                     | <b>4</b>    |
| 1.1            | Disclaimer                                              | 4           |
| 1.2            | Introduction                                            | 4           |
| 1.3            | Notes                                                   | 4           |
| <b>2</b>       | <b>INTRODUCTION TO THE GREEN JET FERTIGATION SYSTEM</b> | <b>5</b>    |
| 2.1            | Document Summary                                        | 5           |
| 2.2            | What is the Green JET?                                  | 5           |
| 2.3            | Product Summary                                         | 6           |
| 2.4            | Applications                                            | 6           |
| <b>3</b>       | <b>STRUCTURE &amp; SPECIFICATIONS</b>                   | <b>7</b>    |
| 3.1            | Green JET Fertigation Unit Basic Materials              | 7           |
| 3.2            | Standard Features                                       | 7           |
| 3.3            | Schemas and Drawings                                    | 8           |
| 3.4            | Inlet / Outlet Dimensions                               | 10          |
| 3.5            | Water Supply                                            | 10          |
| 3.6            | Fertilizer Dosing Capacity                              | 10          |
| <b>4</b>       | <b>INSTALLATION</b>                                     | <b>11</b>   |
| 4.1            | Environmental conditions                                | 11          |
| 4.2            | Hydraulic Installation                                  | 11          |
| 4.2.1          | Water Supply                                            | 12          |
| 4.2.2          | Fertilizer Supply                                       | 12          |
| 4.2.3          | Green JET Installation Instructions                     | 13          |
| <b>5</b>       | <b>APPENDIX A: ADDITIONAL PRODUCTS SUMMARY</b>          | <b>14</b>   |
| 5.1            | Green Field ECO Irrigation Controller                   | 14          |
| 5.2            | Green Comm-Box + Green Net                              | 15          |
| 5.3            | Green EC pH Transmitter                                 | 16          |
| 5.4            | Green JET Dimensions and Weights:                       | 17          |
| <b>6</b>       | <b>WARRANTY</b>                                         | <b>18</b>   |

# 1 Introduction

## 1.1 Disclaimer

Munters reserves the right to make alterations to specifications, quantities, dimensions etc. for production or other reasons, subsequent to publication. The information contained herein has been prepared by qualified experts within Munters. While we believe the information is accurate and complete, we make no warranty or representation for any particular purposes. The information is offered in good faith and with the understanding that any use of the units or accessories in breach of the directions and warnings in this document is at the sole discretion and risk of the user.

## 1.2 Introduction

Congratulations on your excellent choice of purchasing an Green Jet System!

In order to realize the full benefit from this product it is important that it is installed, commissioned and operated correctly. Before installation or using the unit, this manual should be studied carefully. It is also recommended that it is kept safely for future reference. The manual is intended as a reference for installation, commissioning and day-to-day operation of the system.

## 1.3 Notes

Date of release: December 2019

Munters cannot guarantee to inform users about the changes or to distribute new manuals to them.

*NOTE All rights reserved. No part of this manual may be reproduced in any manner whatsoever without the expressed written permission of Munters. The contents of this manual are subject to change without notice.*

# 2 Introduction to the Green JET Fertigation System

- Document Summary
- What is the Green JET?
- Product Summary
- Applications

## 2.1 Document Summary

The document give a detailed overview on the Green JET Fertilizer/Acid Dosing Unit System. The document provides information on the Green JET Unit, its installation and maintenance. In addition, the document provides information on additional Munters products that enable overall system control and management, remote access via the web, as well as control over fertilizer EC and pH levels. Together, this package gives a grower all the tools required to run a 21<sup>st</sup> century farming operation.

## 2.2 What is the Green JET?

Green JET is a fully configurable, cost-effective fertilizer/acid dosing unit system that precisely and accurately injects fertilizers according to field/plant requirements. Requiring minimal capital investment and operating in any site conditions, Green JET optimizes the main irrigation lines' available water flow rate and pressure to ensure maximum efficiency.



*Figure 1: Green JET Unit, Installed and Running*

The Green JET Fertigation units enable growers to precisely control their fertilizer and acid quantities as well as their irrigation water quantities.

## 2.3 Product Summary

Green JET's next-generation Fertigation Systems meet the most demanding modern irrigation and fertilization needs. Green JET's unique dosing technology, together with dosing channels that are based on a precise, efficient Venturi injector with no moving parts, assures reliability and system longevity. For control, the systems employ unique quick action valves developed specially for the chemical industry. EC/pH measurement and control is optional and can be easily added to the systems.



- Flexible/Modular fertigation system
- Suitable for soil and soilless media crops
- Minimal capital investment
- Reduced water, fertilizer and energy consumption
- Very high level of EC and pH control
- Nearly maintenance-free Venturi operations
  - No moving parts
- Easy to install and maintain the system
- Comprehensive application coverage, including greenhouses, open fields, orchards and more
- Highly profitable price/performance ratio

## 2.4 Applications

The most common application of the Green JET is the direct injection method: the dosing unit injects the nutrient solution to the irrigation line of a various crop sections. Depending on the type of crop system, Green JET can provide up to **1000 liters/hour (265 gallon per hour)** of fertilizer and acid solution through each of its **eight** dosing channels. With this direct distribution method, the Green JET is only active during Fertigation. The Green JET can be used for overhead irrigation, drip irrigation, etc.

- Green JET can be assembled with any irrigation controller whether it is 220VAC, 115VAC, DC or DC Latch.
- In case of AC voltage, the system is equipped with a Multi-Stage dosing booster suitable for various voltage of 200-240VAC, 380-480VAC and 660-690VAC.

# 3 Structure & Specifications

This chapter describes the structure of the Green JET Fertigation unit, its main components, sizes and dimensions. The role of the various components is explained.

- Green JET Fertigation Unit Basic Materials
- Standard Features
- Schemas and Drawings
- Inlet / Outlet Dimensions
- Water Supply
- Fertilizer Dosing Capacity

## 3.1 Green JET Fertigation Unit Basic Materials

The Green JET is equipped with the following components:

- Aluminum frame with adjustable legs.
- PVC-U pipe and fittings – PN10&PN16 (Maximum pressure).
- Booster pump: Lowara SV series, Lowara HM series, Ebara Matrix series.
- Venturi injectors: 5-50l/h, 50-600l/h, 300-1,000l/h
- Quick action dosing valve: FIP S12 (up to 600l/h), FIP S22 (up to 1,000l/h)
- Visual flow meters (Rotometers) for fertilizer flow indication
- Manual needle valve for dosing channel calibration
- Switch board with mains voltage components and controller parts
- EC & pH sensors and transmitters
- Fertilizer meters – Arad 1/2" KD, Arad 1/2" SF model, Arad 3/4" PB model
- Irrigation controller with 24VAC outputs (or 24VDC, 12VDC Latch) , digital and analog inputs.

## 3.2 Standard Features

- Controller: Green Field or Green Field Eco (refer to the controllers data sheets for technical details)
- Available in 50/60 Hz, three or single phase power supply
- EC/pH Control Single or double measurement
- Irrigation Flow Rate 5 – 600 m<sup>3</sup>/hour (22 - 2700 GPM)
- System Pressure 2.0– 5.0 bar (29 – 73 PSI).
- Higher pressure is available as per special demand

### 3.3 Schemas and Drawings

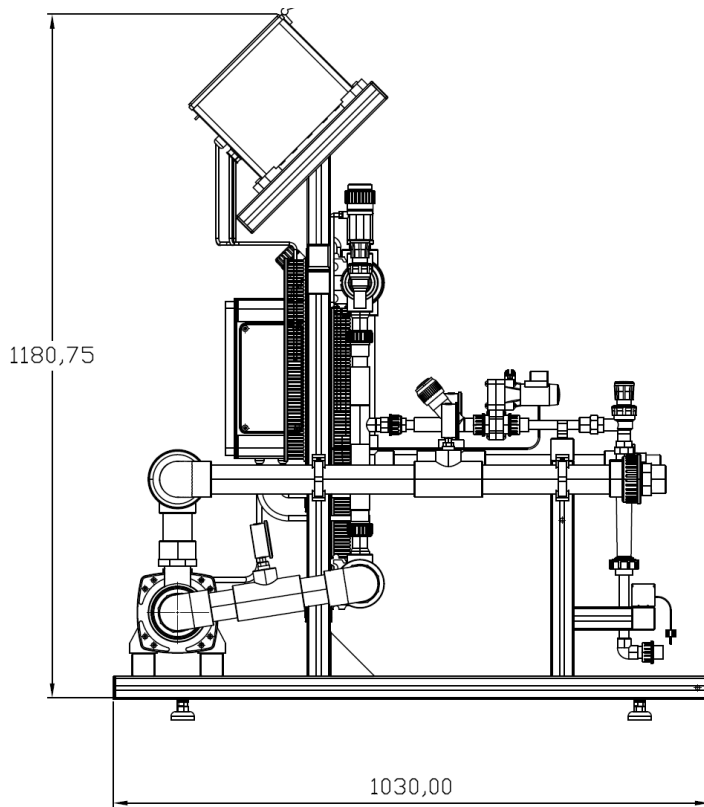

Figure 2: Green JET View (sizes in mm)

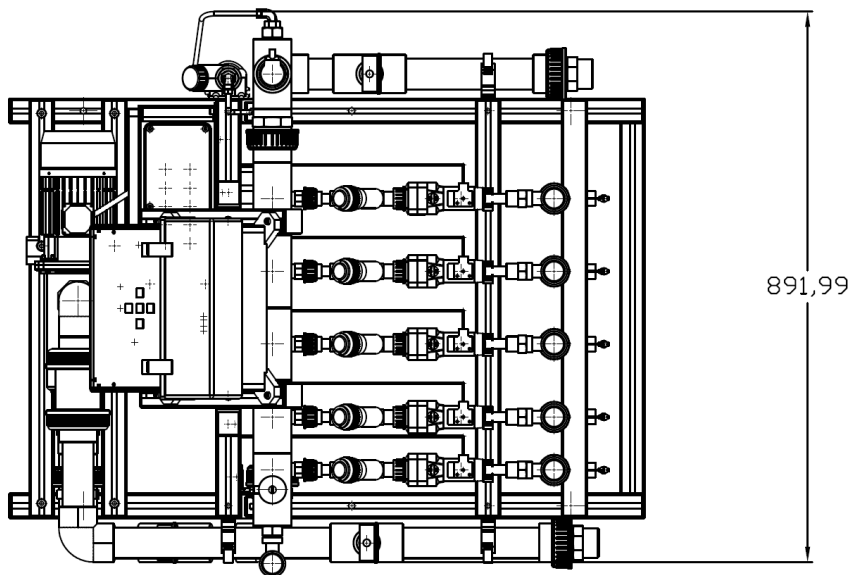

Figure 3: Green JET - High Flow View (sizes in mm)



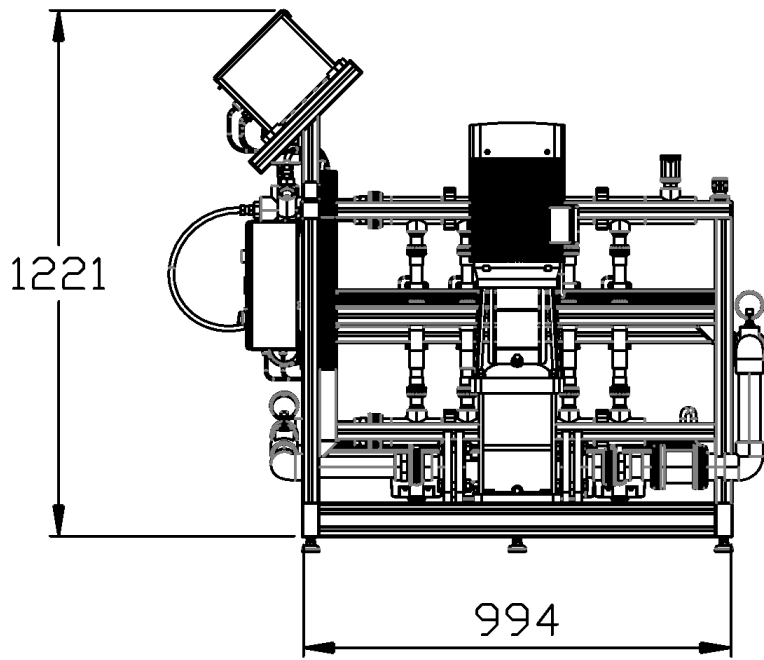

Figure 4: Green JET Dimensions

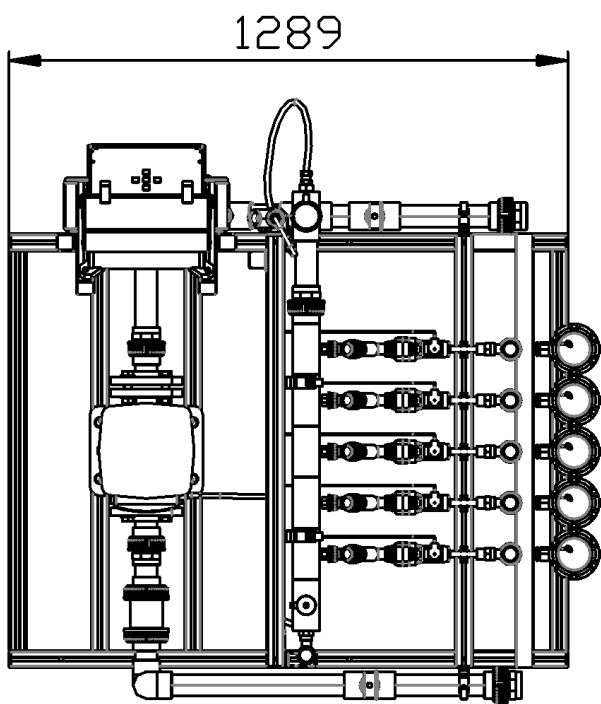

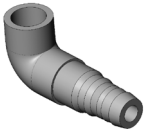

Figure 5: Green JET Dimensions (Top View)

### 3.4 Inlet / Outlet Dimensions

|                                                                                                                    |                                                                                                                |
|--------------------------------------------------------------------------------------------------------------------|----------------------------------------------------------------------------------------------------------------|
| <p>Inlet / Outlet Diameter</p>    | <ul style="list-style-type: none"><li>• Standard - 1.5" Male threaded</li><li>• Optional - 50mm Glue</li></ul> |
| <p>Fertilizer Inlet Diameter</p>  | <ul style="list-style-type: none"><li>• Hose Nozzle - 16-18-16 (mm)</li></ul>                                  |

### 3.5 Water Supply

The working pressure range on the main line should be:

- No more than 6.0 bar (87 psi).<sup>1</sup>
- No less than 3 bar (44 psi).<sup>1</sup>
- Constant in terms of pressure (not fluctuating).
- Suitable for field requirements both in pressure and in flow capacity.
- In case of high levels of bicarbonate in the supply water special measures have to be taken care of to enable proper pH control (see [General requirements > Water supply > Chemical conditioning](#)).

### 3.6 Fertilizer Dosing Capacity

- Maximum dosage capacity per channel is 50 to 1000 liters per hour (13 to 265 gallons per hour) (depending on the system model).
- The minimum recommended fertilizer injection flow rate should be adjusted to 50% of the maximum venturi flow rate. For example, if the venturi flow rate is 600l/h, the recommended flow should be 300l/h or more. This can be done with a needle valve that is installed above the visual flow meter of each and every dosing channel.

---

<sup>1</sup> In case of different pressure requirements; please contact Sales Support for modification.

# 4 Installation

This chapter details the hydraulic and electrical installation instructions for the Green JET dosing unit. The aim of this chapter is to enable and assist technicians and skilled growers to install and commission the Green JET Fertigation unit.

- Environmental conditions
- Hydraulic Installation

## 4.1 Environmental conditions

The Green JET Fertigation Unit has been designed for installation in a greenhouse, service room or a shaded area.

When installing the complete dosing unit, including water supply, fertilizer tanks, etc. the following rules must be observed:

- Install the dosing unit in a shaded area and make sure that it is not exposed to direct sunlight, especially the electrical cabinet.
- Install the dosing unit in an area with an ambient temperature of between 5°C (40°F) and 40°C (105°F) and a maximum relative air humidity of 85 % (without condensation). Make sure it is properly ventilated.
- Install the dosing unit in a dry area protected from splashes, direct spraying with water, or chemicals.
- The dosing unit must be installed on a hard, leveled floor. If it is not possible to install the dosing unit on a hard floor the Green JET must be placed on a flat, hard, leveled plate.
- Ensure that suitable electrical power supply **1.5kw to 7.5kw (depending on which system model is being used)** is available in the vicinity of the installation for connection of the Green JET dosing unit.
- Ensure that there is an electrical socket available in the Green JET vicinity both for installation and for service proposes.

## 4.2 Hydraulic Installation

There are a few rules and recommendation that must observed when installing the Green JET Fertigation units:

- Water Supply
- Fertilizer Supply
- Green JET Installation Instructions

## 4.2.1 WATER SUPPLY

Prior to Green JET installation the following points must be observed and dealt with:

- **Filtering:** A filter of at least 200micron (80 mesh) must be installed before the Green JET Fertigation unit; this is essential to prevent clogging and blockage.
- **Water temperature:**
  - It is important to verify that the irrigation water temperature is always kept in the allowed values of 5 to 40° C (40-105°F).
  - Moreover, a relatively constant temperature will result in the EC control practically not needing temperature compensation which means a more accurate fertilizer injection.
- **Chemical conditioning:**

In case of high levels of bicarbonate concentrations in the supply water it will be practically impossible to accurately control the pH levels. Moreover there will be a difference between the levels measured by the Green JET to the levels measured in the field. In this case it is recommended to pre-treat the water supply by means of acidification. Acid pretreatment of the water is only desirable if the bicarbonate "dissolved carbon dioxide" concentration is too high. This can be done by injecting acid in the inlet to the storage tank. The reaction of the acid with the bicarbonate will result in the release of CO<sub>2</sub>. It is essential that the CO<sub>2</sub> be properly removed before the water is injected with the fertilizers to prevent it from taking part in the chemical reactions.
- **Pressure:**
  - Maximum 6.0 bar (87 psi)
  - Minimum 3.2 bar (45 psi)
  - Constant in terms of pressure (not fluctuating)
  - Suitable for field requirements

## 4.2.2 FERTILIZER SUPPLY

- **Fertilizer tanks:** In order to ensure maximum and even fertilizer capacity the following rules must be observed:
  - The fertilizer tanks must be installed as close as possible to the Green JET. It is recommended to keep a maximum pipe length of 10 meters/33 feet. Nevertheless there has to be enough space between the fertilizer tanks themselves and between the Green JET so that inspection and maintenance operations can be carried out.
  - The fertilizer tanks must be at least the same level as Green JET if not higher.
  - Piping and fittings for all dosing channels must be kept as similar as possible in terms of dimensions and length.
  - It is recommended that the suction from the fertilizer tanks be done about 5-10 cm (2-5 inch) higher than the bottom of the tank. This prevents suction of sediment and reduces the risk of clogging and blockage.
  - The fertilizer tanks should have a minimal storage capacity of one day's fertilizer requirements.
- **Filtering:** It is essential to ensure proper filtering before the Green JET dosing channels; the minimum filter should be of 125 µm (120 mesh).
- **Piping:**
  - Recommended PVC pipe diameter from the tank to the system is 40mm (1.5 inch). The hose connection of the Green JET is suitable for a ½ inch **reinforced** flexible,

- Maximum length 1.5 meter (5 feet). Make sure the hose used is chemical resistant. It is recommended to tighten the hose with a stainless steel hose clip.

#### 4.2.3 GREEN JET INSTALLATION INSTRUCTIONS

Green JET installation is highly dependent on hydraulic conditions at site, in order to ensure proper operation and long term reliability of the system the following rules and recommendations must be observed:

*NOTE The ratio between irrigation water flow / bypass water flow should be no less than 3.5. This is essential because of the solubility of the fertilizers in the bypass water flow.*

- Flow through the Green JET should be calculated as follows:
  - Flow per channel is around 1,500 l/h (400 gallon/h).
  - 900 l/h (240 gallon/h) motive flow + max 600 l/h (160 gallon/h) fertilizer suction). Compensation channel flow is approximately 1,500 l/h (400 gallon/h).
- Flow through the Green JET Hi-Flow should be calculated as follows:
  - Flow per channel is around 4,000 l/h (1060 gallon/h).
  - 3000 l/h (790 gallon/h) motive flow + max 1000 l/h (265 gallon/h) fertilizer suction). Compensation channel flow is approximately 4,000 l/h (1060 gallon/h).

# 5 Appendix A: Additional Products Summary

The following section provides basic information on additional products provided by Munters that can be used to provide an integrated solution to any irrigation project. Munters provides controllers, accessories, and complete communication solutions allowing remote control and management.

- Green Field ECO Irrigation Controller
- Green EC pH Transmitter
- Green Comm-Box + Green Net

*NOTE Product user and installation manuals, which provide full technical details, are available.*



## 5.1 Green Field ECO Irrigation Controller

Munters Green Field ECO Irrigation Controller provides overall control and management over small to medium size irrigation systems, maximizing both the yields and quality of your harvests. A cost-effective solution, Green Field ECO's large range of functionality provides farm managers with the tools needed to automate the irrigation and fertigation processes.

Green Field ECO's software package enables configuring dynamic irrigation programs capable of responding to a range of inputs. Dosing programs provide your crops with the specific amount of fertilizers required, boosting plant growth while reducing expenses.

Green Field ECO's hardware package supports analog and digital inputs as well outputs that can be configured according to your specifications. In addition, the controller supports filter flushing, cooling and misting programs. Use a cable or radio to connect the Green Field with your PC.

The controller can be integrated with Green Net, an advanced software program packaged in a user-friendly, colored GUI. Green Net enables remote control over product configuration and management, climate control, along with analysis of the controller's performance.



- Irrigation according to time or external conditions
- Advanced EC/pH control and monitoring
- Cooling strategy, based on time and/or actual temperature and relative humidity sensors
- Internal surge protection and protection for inputs and outputs
- Works in open-field and greenhouse applications
- Can be installed as an add-on to an existing fertigation system or as a stand-alone
- Program interface supports multiple languages

## 5.2 Green Comm-Box + Green Net

Munters Green Comm-Box enables remote access to your Munters Green House Controllers (Green Field, Green Field ECO, and Green Climate). This access includes complete monitoring and control capabilities.

Access to your system is via TeamViewer, a standard industry remote access program available as freeware.

Green Net, an advanced software program used to manage the controllers, comes installed on the Green Comm-Box units. Once the connection to your system is set up, you can take charge of your system from any PC or smartphone equipped with TeamViewer.



- Full control over your farms' controllers
- User-friendly GUI
- Analysis of controller performance



### 5.3 Green EC pH Transmitter

Munters Green EC pH Transmitter transmits EC and pH sensor data to controllers, providing growers with data required for effective irrigation programs. The EC pH Transmitter converts the relevant signals into a 4 - 20 mA output, which is then sent to a Munters controller.



Controller's proven accuracy provides:

- Accurate, continual EC data helps increase yields
- pH measurement, preventing issues such as nutrient deficiencies or toxicity



Figure 6: Green JET EC pH Unit in Place



## 5.4 Green JET Dimensions and Weights:

### Green JET Inline/Bypass

- Width - 115 cm
- Length - 115 cm
- Height - 140 cm
- Weight - 120 kg

### Green JET High Flow

- Width - 145 cm
- Length - 145 cm
- Height - 140 cm
- Weight - 150 kg

# 6 Warranty

## Warranty and technical assistance

Munters products are designed and built to provide reliable and satisfactory performance but cannot be guaranteed free of faults; although they are reliable products they can develop unforeseeable defects and the user must take this into account and arrange adequate emergency or alarm systems if failure to operate could cause damage to the articles for which the Munters plant was required: if this is not done, the user is fully responsible for the damage which they could suffer.

Munters extends this limited warranty to the first purchaser and guarantees its products to be free from defects originating in manufacture or materials for one year from the date of delivery, provided that suitable transport, storage, installation and maintenance terms are complied with. The warranty does not apply if the products have been repaired without express authorisation from Munters, or repaired in such a way that, in Munters' judgement, their performance and reliability have been impaired, or incorrectly installed, or subjected to improper use. The user accepts total responsibility for incorrect use of the products.

The warranty on products from outside suppliers fitted to Green JET, (for example Green JET's antennas, power supplies, cables, etc.) is limited to the conditions stated by the supplier: all claims must be made in writing within eight days of the discovery of the defect and within 12 months of the delivery of the defective product. Munters has thirty days from the date of receipt in which to take action, and has the right to examine the product at the customer's premises or at its own plant (carriage cost to be borne by the customer).

Munters at its sole discretion has the option of replacing or repairing, free of charge, products which it considers defective, and will arrange for their despatch back to the customer carriage paid. In the case of faulty parts of small commercial value which are widely available (such as bolts, etc.) for urgent despatch, where the cost of carriage would exceed the value of the parts, Munters may authorise the customer exclusively to purchase the replacement parts locally; Munters will reimburse the value of the product at its cost price.

Munters will not be liable for costs incurred in demounting the defective part, or the time required to travel to site and the associated travel costs. No agent, employee or dealer is authorised to give any further guarantees or to accept any other liability on Munters' behalf in connection with other Munters products, except in writing with the signature of one of the Company's Managers.

**WARNING:** In the interests of improving the quality of its products and services, Munters reserves the right at any time and without prior notice to alter the specifications in this manual.

The liability of the manufacturer Munters ceases in the event of:

- dismantling the safety devices;
- use of unauthorised materials;
- inadequate maintenance;
- use of non-original spare parts and accessories.

Barring specific contractual terms, the following are directly at the user's expense:

- preparing installation sites;
- providing an electricity supply (including the protective equipotential bonding (PE) conductor, in accordance with CEI EN 60204-1, paragraph 8.2), for correctly connecting the equipment to the mains electricity supply;
- providing ancillary services appropriate to the requirements of the plant on the basis of the information supplied with regard to installation;
- tools and consumables required for fitting and installation;
- lubricants necessary for commissioning and maintenance.

It is mandatory to purchase and use only original spare parts or those recommended by the manufacturer.

Dismantling and assembly must be performed by qualified technicians and according to the manufacturer's instructions.

The use of non-original spare parts or incorrect assembly exonerates the manufacturer from all liability.

Requests for technical assistance and spare parts can be made directly to the nearest [Munters office](#).

### **Green JET EC and pH Sensors**

The above does not apply to EC and pH sensors, since they are consumable. Munters will warrant these items to be free of defects in material and workmanship for 3 months from the date of installation, provided the installation has been reported to us within 30 days, or 6 months from date of production if installation was not reported, or was reported later than 30 days from the date of installation.

