

Manual for use and maintenance

RFS-6 – Broiler Edition



RFS-6 Broiler Edition

Poultry Feed Control

RFS-6 Broiler Edition

Manual for use and maintenance

Revision: N.1.0 of 03.2019

Ag/MIS/UmGB-2244-05/15 Rev. 2.4 (MIS)

Product Software: 4.01

This manual for use and maintenance is an integral part of the apparatus together with the attached technical documentation.

This document is destined for the user of the apparatus: it may not be reproduced in whole or in part, committed to computer memory as a file or delivered to third parties without the prior authorization of the assembler of the system.

Munters reserves the right to effect modifications to the apparatus in accordance with technical and legal developments.

Index

<i>Chapter</i>		<i>page</i>
1	INTRODUCTION	5
	1.1 Disclaimer	5
	1.2 Introduction	5
	1.3 Notes	5
1	PRECAUTIONS	6
	1.1 Grounding	6
	1.2 Checking the Battery Level	6
2	INTRODUCTION TO THE RFS-6 BROILER	7
	2.1 Display	7
	2.2 Control Menu	7
	2.3 Feeding Curve	7
	2.4 Keypad Keys	8
	2.5 Hot Keys	8
	2.6 Main Menu	9
3	CONTROL MENU	10
	3.1 Feeding Curve	10
	3.2 Feeding Time	11
	3.3 Feed Mixing	11
	3.4 Lighting	11
	3.5 Operation Mode	11
	3.6 Variables	12
4	MANAGEMENT MENU	15
	4.1 Mortality	15
	4.2 Poultry Count	15
	4.3 Feed Silo 1 / 2 / 3	16
	4.4 Silo Inventory	16
	4.5 Time/Date	16
	4.6 Growth Day	16
	4.7 New Flock	17
	4.8 Alarm Reset	17
	4.9 Alarm Time	17
	4.10 Poultry Curve	18
5	HISTORY	19

5.1	Feed Consumption	19
5.2	Water Consumption	19
5.3	Poultry Weight	20
5.4	Feed Conversion	20
5.5	Mortality	20
5.6	Alarms	20
5.7	Feed 1/2/3 Consumption	20
6	TEST MENU	21
6.1	Relays	21
6.2	Feed Scales	21
6.3	Poultry Scale	21
6.4	Digital Inputs	21
6.5	Water Pulse	22
7	CALIBRATION MENU	23
7.1	Feed Scale	23
7.2	Bird Scale	23
7.3	Feed Factor	23
7.4	Bird Scale Factor	24
7.5	Modem Setting	24
8	INSTALLATION	25
8.1	RFS-6 Broiler Installation	25
8.2	Cold Start	27
8.3	RFS-6 Broiler Container Dimensions	27
8.4	RFS-6 Broiler Container Components and Assembly	28
8.5	Specifications	29
8.6	Environmental Protection	29
9	RFS-6 BROILER QUICK GUIDE	30
9.1	Installation	30
9.2	Calibration Menu	30
9.3	Control Menu	30
10	WARRANTY	32

1 Introduction

1.1 Disclaimer

Munters reserves the right to make alterations to specifications, quantities, dimensions etc. for production or other reasons, subsequent to publication. The information contained herein has been prepared by qualified experts within Munters. While we believe the information is accurate and complete, we make no warranty or representation for any particular purposes. The information is offered in good faith and with the understanding that any use of the units or accessories in breach of the directions and warnings in this document is at the sole discretion and risk of the user.

1.2 Introduction

Congratulations on your excellent choice of purchasing an RFS-6!

In order to realize the full benefit from this product it is important that it is installed, commissioned and operated correctly. Before installation or using the fan, this manual should be studied carefully. It is also recommended that it is kept safely for future reference. The manual is intended as a reference for installation, commissioning and day-to-day operation of the Munters Controllers.

1.3 Notes

Date of release: July 2010

Munters cannot guarantee to inform users about the changes or to distribute new manuals to them.

All rights reserved. No part of this manual may be reproduced in any manner whatsoever without the expressed written permission of Munters. The contents of this manual are subject to change without notice.

1 Precautions

- Grounding
- Checking the Battery Level

1.1 Grounding

- Keep the controller as far as possible from heavy contactor boxes and other sources of electrical interference.
- Do not connect communication wire shields, which go from one house to another at both ends. Connect them at one end only. Connection at both ends can cause ground loop currents to flow, which reduce reliability.
- The COM connection for communications is not the shield wire. The COM, RX and TX wires must connect to each other at all controllers.

1.2 Checking the Battery Level

- Check the battery once a year. The output must be 2.7 volts (minimum). Authorized personnel only must replace the battery if the output is below the minimum required level or every five years.

2 Introduction to the RFS-6 Broiler

The Munters **RFS-6 Broiler** is a precision broiler feed control system that includes feed and bird scales enabling the grower to do the following:

- Precisely control feed delivery
- Weigh feed delivery results

The **RFS-6 Broiler** can blend up to three feed sources and deliver feed to four different feed lines. Feed delivery can be set to preset times for meal time feeding, continuous full feeding, or restricted feeding.

This section details the:

- Display
- Control Menu
- Feeding Curve
- Keypad Keys
- Main Menu

2.1 Display

The **RFS-6 Broiler** normally displays the time, delivered feed for today and growth day. When there is an **alarm** the screen alternately displays the alarm message and the standard display. Refer to Figure 1.

DAY 009	FEED 0.0Kg	TIME 13:12
-------------------	----------------------	----------------------

Figure 1: Standard Display View

2.2 Control Menu

Press **Enter** key to view the control menu. Press **Menu** again and the standard display reappears. Note the line underneath the quantity. This is the cursor position, and marks the point at which you can make changes. Refer to Figure 2.

# 1	DAY 1	QTY/BIRD 0.015	TOTAL 205
---------------	-----------------	--------------------------	---------------------

Figure 2: Control Menu

2.3 Feeding Curve

The first item on the control menu is the feeding curve. Press **Enter** to select the feeding curve. The **Menu** key returns to the preceding screen. Refer to Figure 3.



Figure 3: Feeding Curve

2.4 Keypad Keys

The RFS-6 Broiler keypad consists of eight keys; Table 1 describes them.

Table 1: RFS-6 Broiler Keypad Description

Key	Description
Menu	Backs the RFS-6 Broiler out of menus
Enter	Selects or moves the RFS-6 Broiler into menu items, or confirms editing changes.
+ (Plus)	Increments values. The rate at which values increase changes as the keys are depressed. You can increase values by holding the + key and depressing (or holding) on one of the arrow keys. Every arrow has its own factor which multiplies the addition to the value.
- (Minus)	Decrements values. The rate at which values decrease changes as the keys are depressed. You can decrease values by holding the - key and depressing (or holding) on one of the arrow keys. Every arrow has its own factor which multiplies the addition to the value.
◀ (Left)	Moves to the left in all the screens and tables. When there are several entries on a screen, the cursor alone may move. Whenever necessary, the entire screen moves. Multiplies x 10.
▲ (Up)	Moves up menus and tables. Multiplies x 100.
▶ (Right)	Moves to the right in all the screens and tables. When there are several entries on a screen, the cursor alone may move. Whenever necessary, the entire screen moves. Multiplies x 1000 (1K).
▼ (Down)	Moves down menus and tables. Multiplies x 10,000 (10K).

NOTE The RFS-6 Broiler does not accept changes until you confirm them by pressing **Enter**.

2.5 Hot Keys

Press Enter and one of the following keys:

- 10K: Software version
- 10: Relay status
- 100: Silo weight
- 1K: Feed cycle process and the weighing container weight

2.6 Main Menu

Table 2 displays the complete RFS-6 Broiler main menu structure.

Table 2: RFS-6 Broiler Main Menu Structure

CONTROL	MANAGEMENT	HISTORY	TEST	CALIBRATION
1. FEEDING CURVE	1. MORTALITY	1. FEED CONSUMPTION	1. RELAYS	1. FEED SCALE
2. FEED TIME	2. POULTRY COUNT	2. WATER CONSUMPTION	2. FEED SCALE	2. BIRD SCALE
3. FEED MIXINIG	3. FEED SILO 1	3. POULTRY WEIGHT	3. POULTRY SCALE	3. FEED FACTOR
4. LIGHTING	4. FEED SILO 2	4. FEED CONVERSION	4. DIGITAL INPUTS	4. BIRD SCALE FACTOR
5. OPERATION MODE	5. FEED SILO 3	5. MORTALITY	5. WATER PULSE	5. MODEM SETTING
6. SYSTEM PARAMETERS	6. SILO INVENTORY	6. ALARMS		
	7. TIME/DATE	7. FEED 1 CONSUMPTION		
	8. GROWTH DAY	8. FEED 2 CONSUMPTION		
	9. NEW FLOCK	9. FEED 3 CONSUMPTION		
	10. ALARM RESET			
	11. ALARM TIME			
	12. POULTRY CURVE			

3 Control menu

This section details the Control Menu. The Control Menu describes male and female filling and feeding, skipping periods, light exposure and stopping/resuming of the feed function. The following are included in this section:

- Feeding Curve
- Feeding Time
- Feed Mixing
- Lighting
- Operation Mode
- Variables

3.1 Feeding Curve

The Feeding Curve table has ten line entries to specify quantity of feed per bird at specific growth days. For full feeding, set line 1 of the feeding curve to a high value. Refer to Figure 4.

NOTE Zeroing the table completely stops all filling processes!

#	DAY	QTY/BIRD	TOTAL
1	1	1.015	2000
2	5	1.5	21000
3	10	1.7	21500

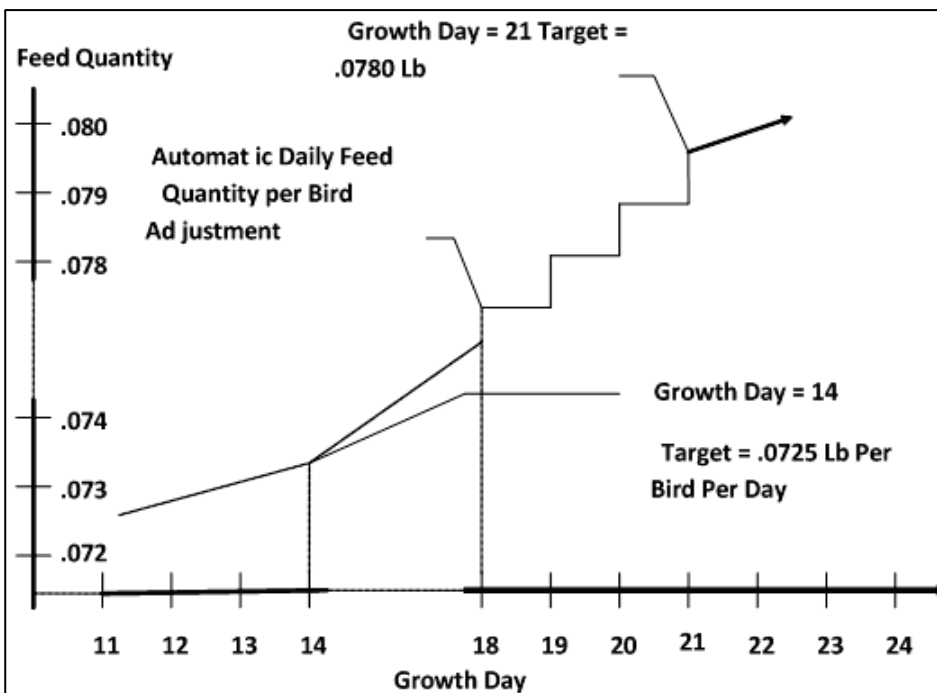

Figure 4: Feeding Curve

3.2 Feeding Time

There are ten table entries for times at which to schedule daily feedings. The time programmed is the beginning and end of each meal for mealtime feeding. For multiple feedings, the **RFS-6 Broiler** feeds equal portions of the day's ration at each feeding. For full feeding, set the quantity/bird on the Feeding Curve Table to a high number (default - 1 Kg/Bird). The feeding time table operates relays 5 and 6 (as extra feeder) which calls starts at the times specified in the table.

#	FROM	TO	ON	OFF
1	10:00	12:00	60	60
2	10:00	13:00	60	60

3.3 Feed Mixing

The **RFS-6 Broiler** supports blending of three feed sources. Enter the percentage for either Auger 2 or Auger 3 at each programmed growth day. The **RFS-6 Broiler** automatically adjusts Auger 1 to total 100%. System parameter 1 controls the number of mixing cycles required prior to feed delivery.

NOTE System parameter 1 controls the number of mixing cycles required prior to feed delivery.

#	DAY	% - 1	% - 2	% - 3
1	1	100	0	0
2	5	90	5	5
3	10	85	5	10

3.4 Lighting

The Lighting option controls the flock's light periods. Enter up to ten time periods for the lights to turn on.

#	FROM TIME	TO TIME
1	06:30	07:00
2	08:30	9:15
3	11:00	12:00

3.5 Operation Mode

The operation mode controls the filling process. There are three modes:

- **AUTO:** The load cell continually weighs the weighing container and allows filling as needed.
- **BYPASS:** Container is filled by time (for example 5 kilograms per minute). Use this option only if the load cell is not working. Feed Scaling automatically calibrates itself at 0:00 AM, so there is no need to calibrate the quantity.
- **STOP:** Stops the filling process.

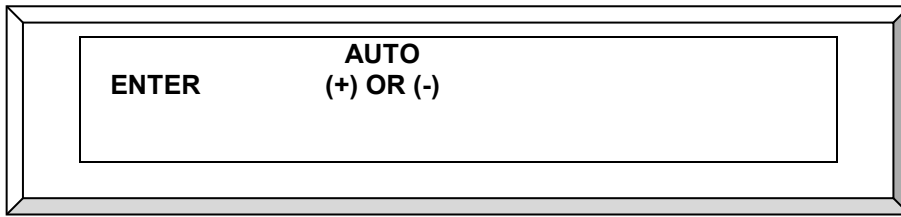

3.6 Variables

RFS-6 Broiler variables, a brief description and default values are listed below.

Parameter No.	Description	Default Value
1	Mixing Cycles 1-10 Number of mixtures for a two auger-unit	1
2	Maximum Portion 1...60 [Kg / Lb] Maximum weight for one portion, for a manual scale	25
3	Max Auger Time 0...60 [minutes] Waiting time before the alarm starts in case auger 1, 2 have not been filled with portion (Alarm Code 5 or 4).	5
4	Not Empty Time 0...1440 [minutes] Waiting time before the alarm starts in case the auger is not empty and still contains more than half a portion (Alarm 6).	3
5	Low Limit 1: 0...65000 [Kg / Lb] If the remaining quantity of feed in Silo 1 is below the low limit, Alarm 7 is triggered.	0
6	Low Limit 2: 0...65000 [Kg / Lb] If the remaining quantity of feed in Silo 2 is below the low limit, Alarm 8 is triggered.	0
7	Feed / Pulse W Ratio 0...100 [Kg / Lb] Relation between the feed quantity and the number of pulses at the exit feed / pulse 1.	10
8	Water / Pulse Ratio 0...100 Relation between the water quantity and the number of pulses at the entry water / pulse.	0.000
9	Reference [Kg / Lb] Weight to which measurements are compared, to check that they are within the desired range.	0.000
10	% Below 10...45 [%] Measurements in %, within the range below the reference weight.	30

Parameter No.	Description	Default Value
11	% Above 10...45 [%] Measurements in %, within the range above the reference weight.	30
12	Autocorrection [0=No 1=Yes] Activation of "automatic adjustment" of the average weight, for the chicken scale. <ul style="list-style-type: none"> • 1: Activation • 0: Disable 	1
13	Female W [Kg / Lb] Reference weight for Female. (cannot be set by the user)	0.039
14	Male W [Kg / Lb] Reference weight for Male. (cannot be set by the user)	0.045
15	(+) Female % 10...45 [%] Measurements in %, within the range above the female reference weight.	15
16	(-) Female % 10...45 [%] Measurements in %, within the range below the female reference weight.	15
17	(+) Male % 10...45 [%] Measurements in %, within the range above the male reference weight.	15
18	(-) Male % 10...45 [%] Measurements in %, within the range below the Male reference weight	15
19	Feed1 / Min [Kg / Lb] In a bypass situation, the feed quantity that passes through Auger 1 in one minute (measured during regular work).	0.0
20	Feed2 / Min [Kg / Lb] In a bypass situation, the feed quantity that passes through Auger 2 in one minute (not working)	0.0
21	Midnight [hours] User-determined time for midnight point	00
22	House NO. Communication: house number	0
23	Password Communication: password	0

Parameter No.	Description	Default Value
24	Baud Rate Communication: baud rate	9600
25	Weight Mode [REG / MIX] Regular mode or mixed male and female mode	REG
26	Extra feeder [0= NO, 1=YES]	0
27	Weight Unit [Kg, Lb] Measurement unit	Kg
28	Date Format [USA or Europe] American or European date format	Europe
29	Flock Number	1
30	Uniformity % Allowable variation in bird weights	5-30%

4 Management menu

The following are included in this section:

- Mortality
- Poultry Count
- Feed Silo 1 / 2 / 3
- Silo Inventory
- Time/Date
- Growth Day
- New Flock
- Alarm Reset
- Alarm Time
- Poultry Curve

4.1 Mortality

Enter dead bird counts each time you enter the house. The **RFS-6 Broiler** maintains the total daily count automatically. To correct the daily total, press the **Enter** key and the cursor moves to the daily sum line. You can edit this value with the +, - keypad keys followed by the **Enter** key (the maximum mortality per day is 6500).

ADD MORTALITY	15
DAILY SUM	15

4.2 Poultry Count

The Poultry Count screen maintains the current flock count.

- When the new flock arrives, enter the number of chicks.
- As you edit the Mortality screen, the Poultry Count screen automatically corrects the Update Chicks field.

INITIAL CHICKS:	20000
UPDATE CHICKS:	19985

4.3 Feed Silo 1 / 2 / 3

The Feed Silo screens records the amount of feed added to Feed Silos 1, 2, and 3. Add up to 99 lines of data (date feed is added and the amount).

##	DATE	SILO-1
1	01-01-12	1000
2	01-15-12	1000

4.4 Silo Inventory

The Silo Inventory screen displays the current amount of feed in each silo.

SILO-1	SILO-2	SILO-3
900	700	700

4.5 Time/Date

In this screen, enter the current time and date.

ENTER TIME:	07:50
ENTER DATE:	02-17-16

4.6 Growth Day

Use this screen to correct the growth date.

GROWTH DAY UPDATE	
ENTER NEW DAY:	4

Code	Alarm
5	Augers 2,3 Overrun
6	Weigh tank not empty
7	Silo 1 Empty
8	Silo 2 Empty
9	Memory Failure
10	Power Loss
11	Power Restore

4.10 Poultry Curve

The RFS-6 can weigh the male and female birds separately by one platform, and calculate an accurate average weight in the broiler house. This menu item enables setting the estimate reference growth curve for male and female.

NOTE: *The dates are preset (every 7 days). Only the curve can be edited.*

DAY	FEMALE	MALE
1	0.039	0.045
7	0.149	0.173
14	0.383	0.450

Table 4: RFS-6 Default Settings

Day	Female	Male
1	0.039	0.045
7	0.149	0.173
14	0.383	0.450
21	0.714	0.839
28	1.100	1.296
35	1.530	1.798
42	1.950	2.289
49	0	0
56	0	0

5 History

The following section includes:

- Feed Consumption
- Poultry Weight
- Mortality
- Feed 1/2/3 Consumption
- Water Consumption
- Feed Conversion
- Alarms

5.1 Feed Consumption

The RFS-6 maintains a daily feed consumption record for the flock throughout the growth period. This screen displays the data, showing:

- the day, quantity per bird, cumulative data on first screen
- quantity per bird and daily change data on second screen
- left and right arrows toggle between the two screens

DAY	QTY	ACC.	QTY/B	%GAIN
2	0	0	0.000	N/A

5.2 Water Consumption

The RFS-6 maintains a daily water consumption record for the flock throughout the growth period. This screen displays the data, showing:

- the day, quantity per bird, cumulative data on first screen
- quantity per bird and daily change data on second screen
- left and right arrows toggle between the two screens

DAY	QTY	ACC.	QTY/B	%GAIN
2	0	0	0.000	N/A

5.3 Poultry Weight

The RFS-6 maintains daily bird weighing counts, average weights, uniformity and standard deviations for the entire flock growth period.

DAY	AVG.	COUNT	UNI.	S.D
2	0	0	0.000	0.000

5.4 Feed Conversion

Using the poultry weight and feed consumption data, the RFS-6 calculates and displays the feed conversion factor alongside the average bird weight, for each growth day. Feed conversion is the quantity of feed delivered per kilogram of feed received.

DAY	BIRD	FEED	F/C
2	0.000	0	0.000

5.5 Mortality

This menu item displays the daily total of the cumulative mortality data, and the percentage change from the initial number of chicks.

DAY	DAILY	ACCUM.	-%-
2	0	0	0.0

5.6 Alarms

The RFS-6 maintains a record of the last 20 alarms. This item displays the growth day, time and alarm code for each of these alarms. The codes shown are listed in Table 3.

##	DAY	TIME	CODE-
1	1	14:01	11

5.7 Feed 1/2/3 Consumption

This menu item displays the feed consumption data for Silos 1, 2, and 3, similar to the total feed consumption item above.

DAY	FEMALE	TIME
002	0.0Kg	09:11

6 Test menu

Test mode enables you to test various system controls and actions. The following section includes:

- Relays
- Feed Scales
- Poultry Scale
- Water Pulse

6.1 Relays

This option manually controls each relay.

To control each relay manually:

1. Use the left and right directional arrow keys to move the cursor to the desired relay number you wish to change.
2. Press the **Enter** keypad key to toggle the relay on and off.

NOTE The RFS-6 Broiler does not operate automatically while in the Relay test mode.

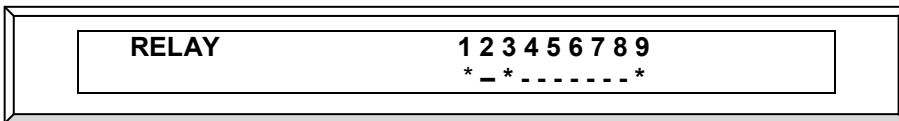

6.2 Feed Scales

The Scales menu item displays the internal machine numbers for the present feed scale readings. If you know the weight at two points, you can calculate the conversion factors for the load cells. It also displays the weight in Kg or in Lb for the feed load cell.

6.3 Poultry Scale

The Scales menu item displays the internal machine numbers for the present poultry scale readings. If you know the weight at two points, you can calculate the conversion factors for the scales. It also displays the weight in Kg or in Lb for the feed load cell.

6.4 Digital Inputs

The digital inputs are available for sensor input. The display displays '0' for an open input, and '1' for a short to COM point. Digital Input 1 is connected to the maximum hopper to indicate the maximum filling of the fill system.

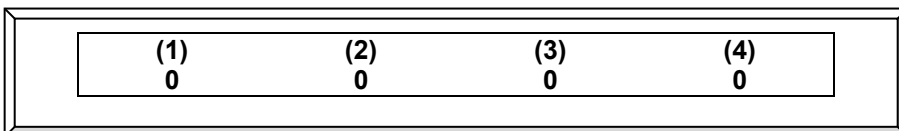

6.5 Water Pulse

You can view the present water meter count to check that it is performing as required.



7 Calibration menu

The following sections detail the calibration processes.

- Feed Scale
- Bird Scale
- Feed Factor
- Bird Scal
- Modem Setting

7.1 Feed Scale

The feed scale periodically requires calibration.

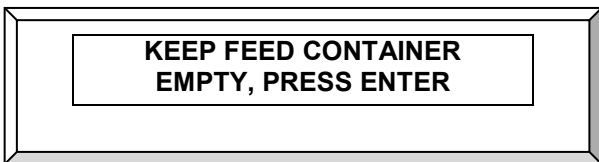

To calibrate the feed scale:

1. When the scale is empty, press **Enter**.
2. Place a known weight on the scale and enter its value.
3. Press **Enter** and a success/failure message appears.

7.2 Bird Scale

To calibrate the poultry scale, you need an accurate weight (minimum one pound / 454 grams; maximum 50 pounds / 20 kilograms). To obtain an inexpensive known weight, use a two liter soda bottle (or equivalent). Weigh it on an accurate calibrated scale such as those used in grocery stores. Follow the instructions on the display.



NOTE To calibrate accurately, Munters recommends using five kilograms or more of a known weight.

7.3 Feed Factor

Munters factory calibrates each feed scale platform prior to shipment. Instead of using an accurate weight, you may simply enter the calibration number from the scale. There is also a zero (tare) number for the feed scale that needs to be entered. The feed factor and the zero number are set automatically after a good calibration.

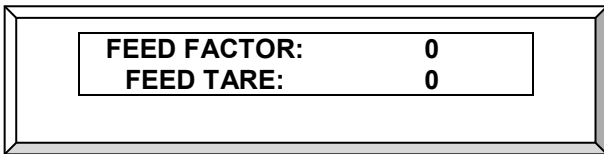

NOTE Every platform has its own number. Do not use the number from one platform to calibrate another one.

7.4 Bird Scale Factor

This is the factor for the poultry scale set after calibration. This number can be changed manually after calibration, or entered after a COLD START.

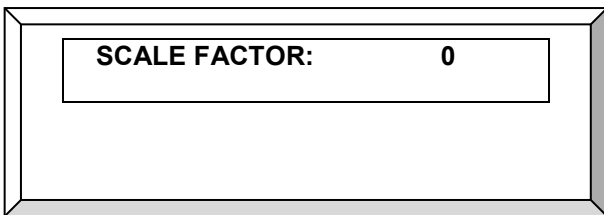

7.5 Modem Setting

To setup the remote modem press the **Enter** keypad key under one of the modem types (use Generic type if there are no other types) and this sends a setup string to the connected modem and returns to the Modem Setting menu.

NOTE The string that is sent to the modem by Generic type is: *AT&FE0V0S0=1&D0&W&Q5&K0&W*

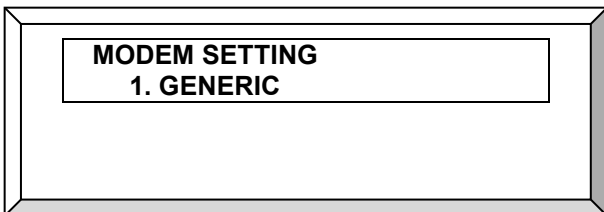

8 Installation

- RFS-6 Broiler Installation
- Cold Start
- RFS-6 Broiler Container Dimensions
- RFS-6 Broiler Container Components and Assembly
- Specifications
- Environmental Protection

8.1 RFS-6 Broiler Installation

The RFS-6 Broiler must be installed by an authorized electrician.

CAUTION To avoid exposing the RFS-6 Broiler to harmful gases or high humidity, it is recommended to install the device in the service room.

CAUTION Installation Category (Overvoltage Category) III.

CAUTION The power supply to the controller should be protected by a 5 Amps circuit breaker.

WARNING! Disconnect the power to avoid electrical shock and damage.

To install the RFS-6 Broiler:

1. Open the **RFS-6 Broiler** controller enclosure lid by unfastening the two screws on the left-hand side in the front cover. The front cover swings open.
2. Position the required cables through the cable holders at the bottom of the RFS-6 Broiler controller enclosure. Connect the wires according to the wiring diagrams. Refer to Figure 5.

NOTE: The **RFS-6 Broiler** must be installed with a **Line Protector (P/N: RPLP-1)** to provide EMI and lightning protection for the unit's power input. In limited cases of very noisy power lines an isolated transformer may also be required.

The **RFS-6 Broiler** controller should be installed a proper distance from high power lines and other electrical/mechanical equipment (i.e. Augers power, variable speed, dimmers, etc.) or another noisy units. A distance of at least 0.5 meter distance should be maintained between the **RFS-6 Broiler** controller and the noise source.

As the load cell cable carries mV it must be a shielded cable grounded on the **RFS-6 Broiler** side. This cable must also not be close to source of noise such as high power cables, and a distance of at least 0.5 meter distance should be maintained.

The water pulse should also be a shielded cable grounded on one side, and kept a safe distance from high power cables.

3. Close the **RFS-6 Broiler** enclosure lid carefully and tightly. Use of RTV silicon or equivalent sealant to seal the cable holders is highly recommended.

4. After initial **RFS-6 Broiler** installation is completed, operate the **RFS-6 Broiler** for a test period and check for proper operation.

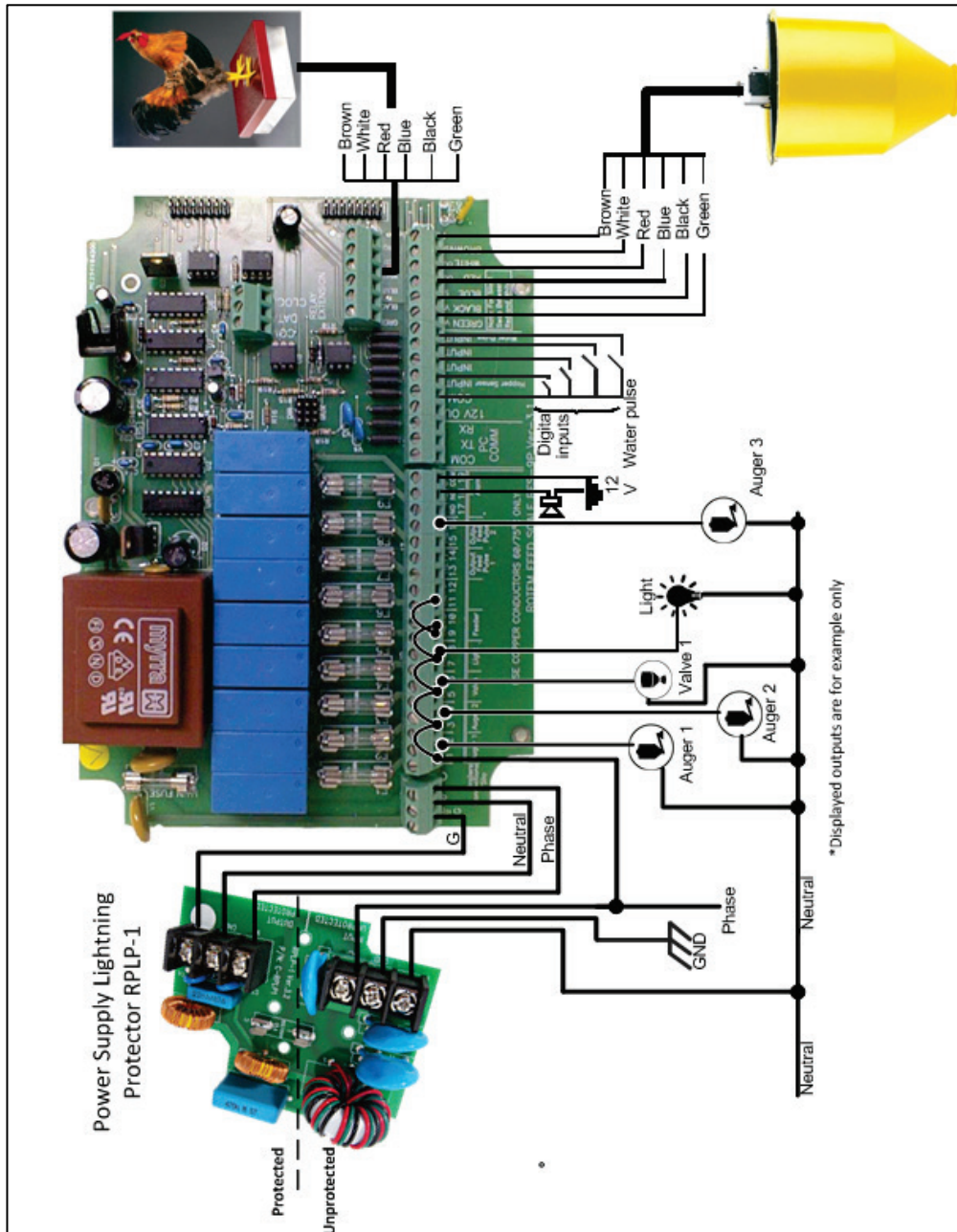

Figure 5: General Wiring Diagram

8.2 Cold Start

The Cold Start returns the values for all the parameters to the factory default and erases the history. Perform a Cold Start *only* after changing software (EEPROM) in the RFS-6 Broiler *or* if there is a main issue with the unit.

NOTE: *It is strongly suggested to create a backup file of all the variables, hidden parameters, tables, and other user programmed variables, so that they can be re-entered after a Cold Start.*

NOTE: *After a Cold Start you must recalibrate the feed and bird scales to retrieve the scale factors, or to enter all factors (include the zero factor for RFS-6 Broiler) manually.*

To activate a Cold Start:

- Simultaneously press the following keypad keys: **Enter**, **MENU**, **+,-**, and turn off and on again the device. The message RUN and then COLD appear on the display.

8.3 RFS-6 Broiler Container Dimensions

RFS-6 Broiler container components and dimensions are listed in Figure 6.

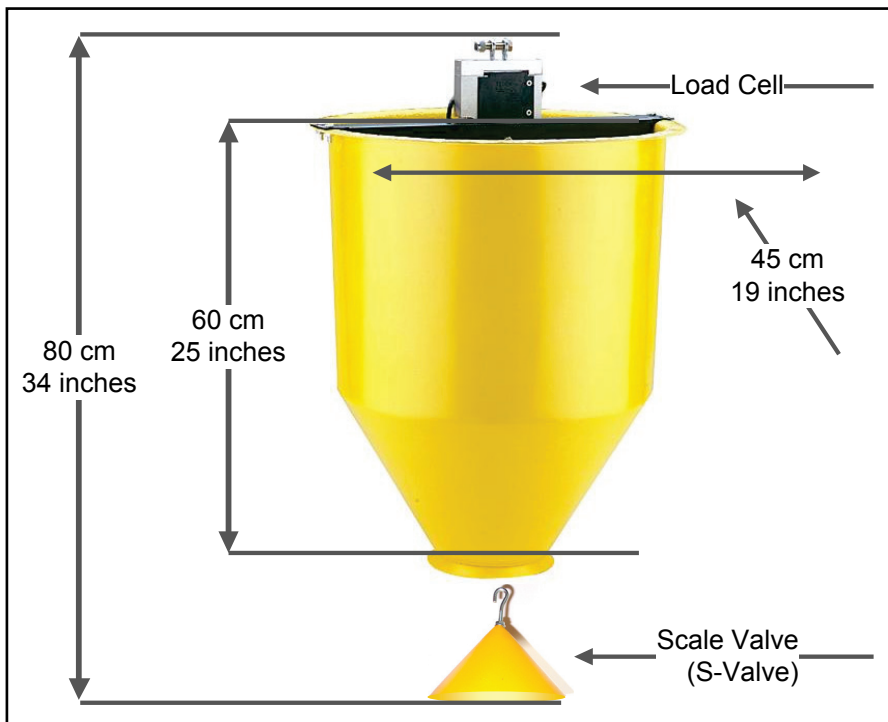

Figure 6: RFS-6 Broiler Container Component Dimensions

8.4 RFS-6 Broiler Container Components and Assembly

The RFS-6 Broiler container is composed of the following:

- Scale Container
- Valve Motor and Load
- Scale Valve

Refer to Figure 7.



Figure 7: RFS-6 Broiler Container Components



Figure 8: Assembled RFS-6 Broiler

To assemble the RFS-6 Broiler:

1. Insert the Valve Motor and Load Cell component into the top of the Feed Container and screw it to the container.
2. Insert the Scale Valve component at the bottom of the Scale Container and hook it onto the Valve Motor.

8.5 Specifications

Input Voltage Supply	Single phase 110 VAC (USA and Canada) Single phase 240 VAC (outside the USA and Canada) 0.315 Amps 50 - 60 Hz
Relays Outputs	5 Amps Normally Open (N.O.) Relays
Alarm Output	N.O. and N.C. Pilot Duty
Operating Temperature Range	0°C to 50°C (14°F to 122°F)
Enclosure	Water and dust tight (IP55)
Fuses	Main Fuse: 0.315 Amps Slow Relays Fuse: 5 Amps Slow

8.6 Environmental Protection



Recycle raw materials instead of disposing as waste. The controller, accessories and packaging should be sorted for environmental-friendly recycling. The plastic components are labeled for categorized recycling.

9 RFS-6 Broiler Quick Guide

This section provides a basic setup guide for the RFS-6 Broiler. For a more detailed guide, refer to the previous sections.

- Installation
- Calibration Menu
- Control Menu

9.1 Installation

1. Connect the Main Silo Auger to Relay 1.
2. Connect the RFC valve to Relay 3.
3. Connect the feeder to Relay 5.

9.2 Calibration Menu

- In Calibration > Feed Scale, calibrate the RFC-1. Refer to the manual for detailed instructions.

9.3 Control Menu

1. In Control > Feeding Curve, define the daily amount of feed to be delivered, per bird.

NOTE This process begins at midnight. To set a different time, go to Control > System Parameters > Midnight. Set the required time to weigh the feed.

2. In Control > Feed Time, define the time period that the feeders operate (receive feed from the hoppers) and cycle time.
3. In Control > Operation Mode, define how the feeders operate:
 - Automatically: according to RFS-6's configuration
 - Bypass: according to a fix amount (weight/time)
 - Stop: feeders cease to operate

NOTE Refer to the RFS-6 manual for details.

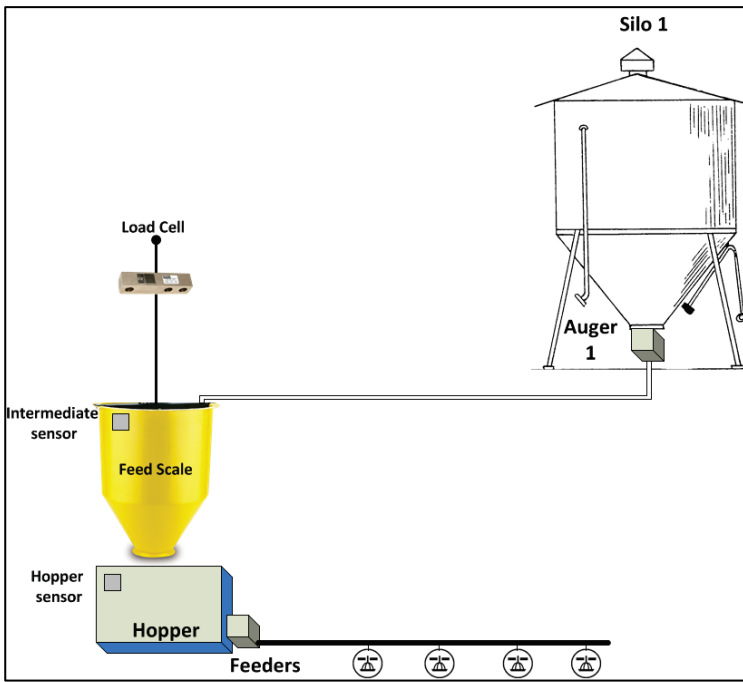

10 Warranty

Warranty and technical assistance

Munters products are designed and built to provide reliable and satisfactory performance but cannot be guaranteed free of faults; although they are reliable products they can develop unforeseeable defects and the user must take this into account and arrange adequate emergency or alarm systems if failure to operate could cause damage to the articles for which the Munters plant was required: if this is not done, the user is fully responsible for the damage which they could suffer.

Munters extends this limited warranty to the first purchaser and guarantees its products to be free from defects originating in manufacture or materials for one year from the date of delivery, provided that suitable transport, storage, installation and maintenance terms are complied with. The warranty does not apply if the products have been repaired without express authorisation from Munters, or repaired in such a way that, in Munters' judgement, their performance and reliability have been impaired, or incorrectly installed, or subjected to improper use. The user accepts total responsibility for incorrect use of the products.

The warranty on products from outside suppliers fitted to RFS-6, (for example, power supplies, cables, etc.) is limited to the conditions stated by the supplier: all claims must be made in writing within eight days of the discovery of the defect and within 12 months of the delivery of the defective product. Munters has thirty days from the date of receipt in which to take action, and has the right to examine the product at the customer's premises or at its own plant (carriage cost to be borne by the customer).

Munters at its sole discretion has the option of replacing or repairing, free of charge, products which it considers defective, and will arrange for their despatch back to the customer carriage paid. In the case of faulty parts of small commercial value which are widely available (such as bolts, etc.) for urgent despatch, where the cost of carriage would exceed the value of the parts, Munters may authorise the customer exclusively to purchase the replacement parts locally; Munters will reimburse the value of the product at its cost price.

Munters will not be liable for costs incurred in demounting the defective part, or the time required to travel to site and the associated travel costs. No agent, employee or dealer is authorised to give any further guarantees or to accept any other liability on Munters' behalf in connection with other Munters products, except in writing with the signature of one of the Company's Managers.

WARNING: In the interests of improving the quality of its products and services, Munters reserves the right at any time and without prior notice to alter the specifications in this manual.

The liability of the manufacturer Munters ceases in the event of:

- dismantling the safety devices;
- use of unauthorised materials;
- inadequate maintenance;
- use of non-original spare parts and accessories.

Barring specific contractual terms, the following are directly at the user's expense:

- preparing installation sites;
- providing an electricity supply (including the protective equipotential bonding (PE) conductor, in accordance with CEI EN 60204-1, paragraph 8.2), for correctly connecting the equipment to the mains electricity supply;
- providing ancillary services appropriate to the requirements of the plant on the basis of the information supplied with regard to installation;
- tools and consumables required for fitting and installation;
- lubricants necessary for commissioning and maintenance.

It is mandatory to purchase and use only original spare parts or those recommended by the manufacturer.

Dismantling and assembly must be performed by qualified technicians and according to the manufacturer's instructions.

The use of non-original spare parts or incorrect assembly exonerates the manufacturer from all liability.

Requests for technical assistance and spare parts can be made directly to the nearest Munters office. A full list of contact details can be found on the back page of this manual.

Munters Israel: 18 HaSivim Street

Petach-Tikva 49517, Israel

Telephone: +972-3-920-6200

Fax: +972-3-924-9834

support@munters.co.il



www.munters.com

Australia Munters Pty Limited, Phone +61 2 8843 1594, **Brazil** Munters Brasil Industria e Comercio Ltda, Phone +55 41 3317 5050, **Canada** Munters Corporation Lansing, Phone +1 517 676 7070, **China** Munters Air Treatment Equipment (Beijing) Co. Ltd, Phone +86 10 80 481 121, **Denmark** Munters A/S, Phone +45 9862 3311, **India** Munters India, Phone +91 20 3052 2520, **Indonesia** Munters, Phone +62 818 739 235, **Israel** Munters Israel Phone +972-3-920-6200, **Italy** Munters Italy S.p.A., Chiusavecchia, Phone +39 0183 52 11, **Japan** Munters K.K., Phone +81 3 5970 0021, **Korea** Munters Korea Co. Ltd., Phone +82 2 761 8701, **Mexico** Munters Mexico, Phone +52 818 262 54 00, **Singapore** Munters Pte Ltd., Phone +65 744 6828, **South Africa and Sub-Sahara Countries** Munters (Pty) Ltd., Phone +27 11 997 2000, **Spain** Munters Spain S.A., Phone +34 91 640 09 02, **Sweden** Munters AB, Phone +46 8 626 63 00, **Thailand** Munters Co. Ltd., Phone +66 2 642 2670, **Turkey** Munters Form Endüstri Sistemleri A.Ş., Phone +90 322 231 1338, **USA** Munters Corporation Lansing, Phone +1 517 676 7070, **Vietnam** Munters Vietnam, Phone +84 8 3825 6838, **Export & Other countries** Munters Italy S.p.A., Chiusavecchia Phone +39 0183 52 11

© Munters AB, 2018