

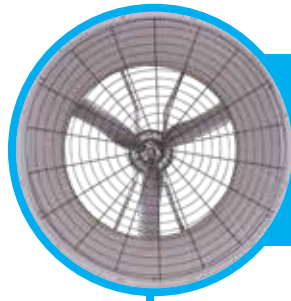

BROCHURE

Positive Pressure Filtered Swine Facilities

trust experience



VX51 with Munters Drive



BI28 Ceiling Inlet

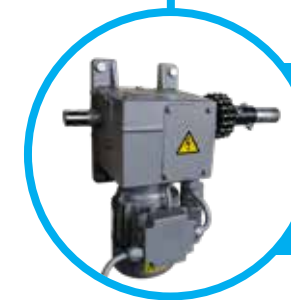
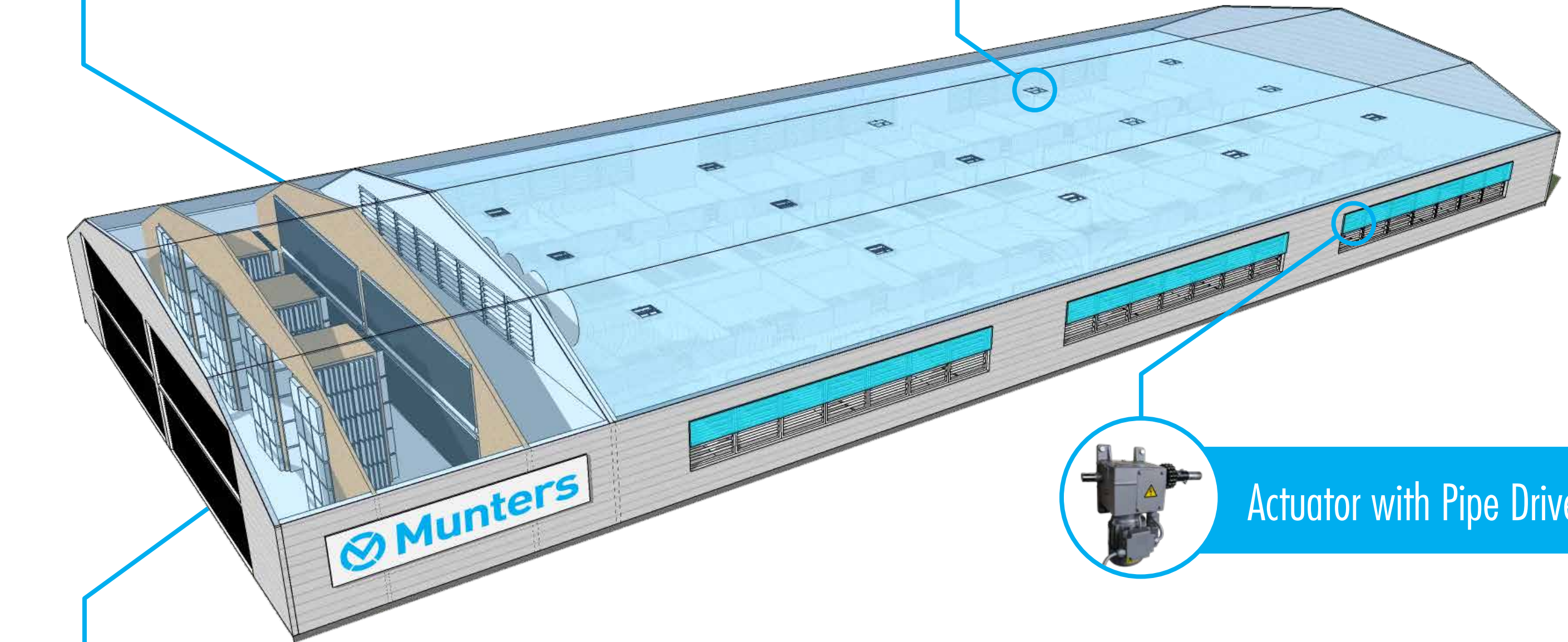

Actuator with Pipe Drive



CT Cooling with CELdek

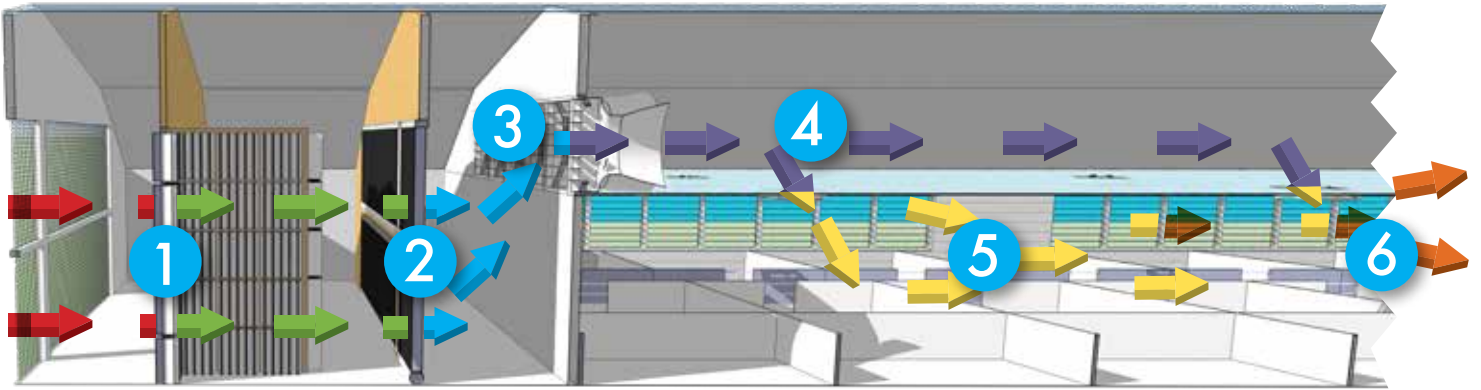

The System

Munters has been designing and refining filtered swine facility ventilation for many years. Our design engineers have worked with some of the top hog producers in the world leading us to our Positive Pressure Ventilation Design.

This is not a new concept. In fact, Munters was designing positive pressure systems nearly 50 years ago. However, with the development of filtration for animal health, positive pressure gives you the best results for healthy livestock. Our latest design incorporates filters, cooling, Munters Drive VX Fans, BI28 Inlets and actuated outlet walls. All carefully engineered to create a Positive Pressure Ventilation System that will protect your animals.

1. Outdoor unfiltered ambient temperature air passes through filter wall, removing airborne pathogens.
2. Filtered air passes through cooling wall, cooling the air to the perfect temperature.
3. Munters Drive VX fans precisely pressurize the attic with filtered & cooled air.
4. Ventilation flows through BI28 Inlets responding to pressure difference from attic to Animal Housing, maintaining a consistent pressure difference between the attic and animal housing
5. Munters back draft shutters prevent pressure drops and back drafts in windy condition
6. Actuator with pipe drive system adjusts curtain openings to maintain constant room pressure and provide outlet for metabolic gases and moisture.

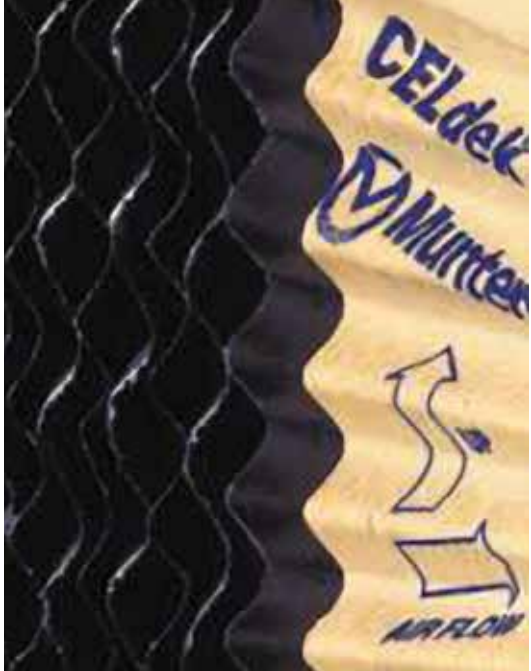

CT Cooling with CELdek

- CT Cooling frame system is the benchmark of the industry
- Corrosion resistant extruded aluminum header
- Designed to assure even and complete water coverage for max performance
- Custom designed drip collect for maximum water capacity and easy installation
- UV resistant PVC reservoir
- Heavy duty extruded aluminum wall mounting brackets
- Proven performance and durability

CT Footer

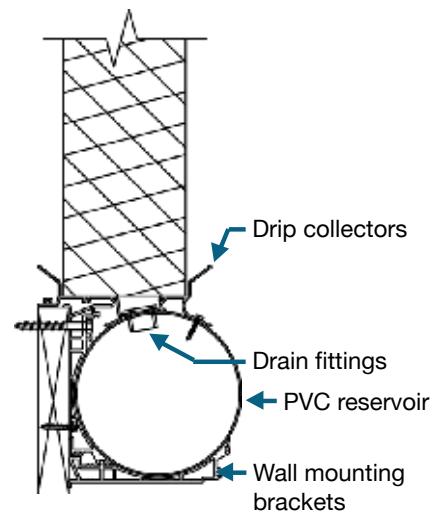

CT Header

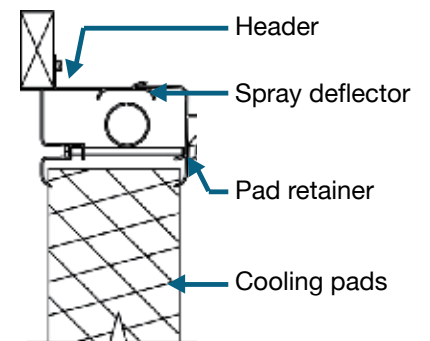



Vortex 51 Munters Drive

Munters was the first to introduce EC motor technology to the large diameter fans specifically for agriculture. Then, we revolutionized that technology with the Munters Drive. Designed, engineered, and built by Munters engineers who are farmers themselves, the Munters Drive reduces costs across dairy, swine, poultry, and greenhouse production by solving some of the most persistent issues facing farm managers, tech managers, and controllers.

Today, more than 30,000 units are in use at over 1,400 farms worldwide, with the first Drives installed exceeding 100,000 hours of continuous operation.

Munters Drive reduces costs by:

- Lowering electrical usage — save up to 40% annually.
- Qualifying you for rebates from utility companies.
- Decreasing the need for complex wiring systems.
- Being virtually maintenance-free.
- Retrofitting to existing systems.
- Qualifies for energy rebate

VX51 Three Phase - 460V	RPM	0.00" SP		0.05" SP		0.10" SP		0.15" SP		0.20" SP		Airflow Ratio	BESS Lab Test
		CFM	CFM/WATT	CFM	CFM/WATT	CFM	CFM/WATT	CFM	CFM/WATT	CFM	CFM/WATT		
High Efficiency - HE	540	28,300	30.4	26,700	27.1	24,700	23.9	22,500	20.9	19,900	18.0	0.75	12679
High Rebate - HR	593	31,200	25.8	29,900	23.3	28,200	21.1	26,300	18.8	24,100	16.7	0.81	12680
High Output - HO	655	34,800	21.2	33,300	19.4	31,900	17.7	30,400	16.2	28,700	14.8	0.86	12681



BI28 Ceiling Inlet Positive Pressure Model

Aerodynamic frame and door design with doors that are insulated and close tightly to prevent condensation. The closure latch hardware and door hinges are made from high quality stainless steel. The special Positive Pressure version is built to handle the unique environment of a positive pressure facility.

Catalog No.	0.1" SP	0.125" SP	0.15" SP
BI28SP/SPM	2,100 CFM	2,575 CFM	3,000 CFM
BI28M-PP01	2,700 CFM	3,050 CFM	3,300 CFM
BI48M-01	4,900 CFM	5,500 CFM	6,100 CFM

LA Actuator With Pipe Drive Kit

Extremely quiet, self-locking worm gear units with long service life, zero-maintenance. Universal mounting with standard at back or optional on side left (symmetrical). Quality motors with multi-range voltage. It is easy to install and use with 100% sealed components. Also available with a potentiometer.



Trust Experience: 95% of all positive pressure buildings in the US are designed and equipped with Munters Ventilation Systems.

Munters Positive Pressure Filterd Swine Facilities

Munters has the experience you can trust to ensure your animals are protected and highly productive. Learn more at our website.

www.munters.com/ppswine

Find your nearest Munters office at www.munters.com

Munters reserves the right to make alterations to specifications, quantities, etc., for production or other reasons, subsequent to publication. © Munters AB, 2022