

**Each Kit includes:**

- 1 - Brace, Coated Steel
- 1 - 1/4" x 3/4" Wafer Head Screw, SS
- 1 - 1/4" Flange Nut, SS
- 1 - 3/8" x 3 1/2" Lag Screw, ZP

## INSTALLATION INSTRUCTIONS

- 1) If pipe is installed, drain all water from the Pipe Reservoir. Take care not to drill into pipe, lift up pipe to allow enough room to work with Pipe Support Bracket.
- 2) Drill a 9/32" hole into the Pipe Support Bracket, 4 7/8" from wall framing. **See Figure 1.**
- 4) With small hole in Brace against bottom of Pipe Support Bracket, fasten together using (1) Wafer Head Bolt and Nut (provided), tighten. Nut must be on bottom side. **See Figure 2.**
- 5) Pre-drill framing for lag screw using 1/4" drill bit. **See Figure 2.** Using the large hole in the Brace, fasten Brace through 1 x 4 and into wall post or stud with (1) 3/8" x 3 1/2" lag screw (provided). **See Figure 2.**
- 6) Repeat Steps 2-5 for each Pipe Support Bracket.

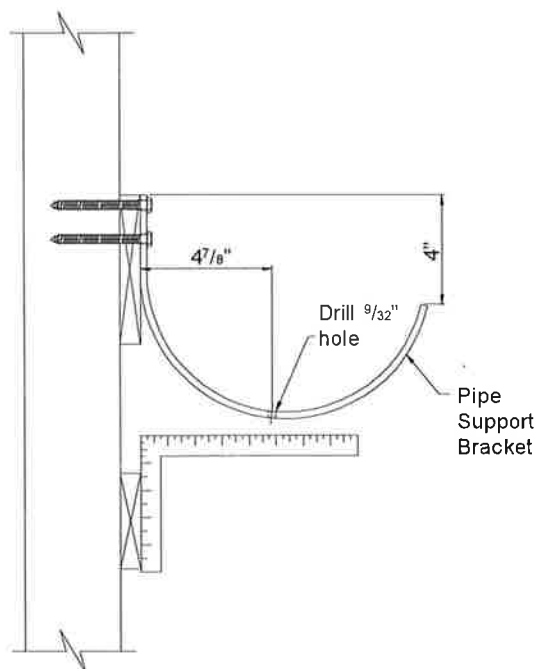

**Figure 1**

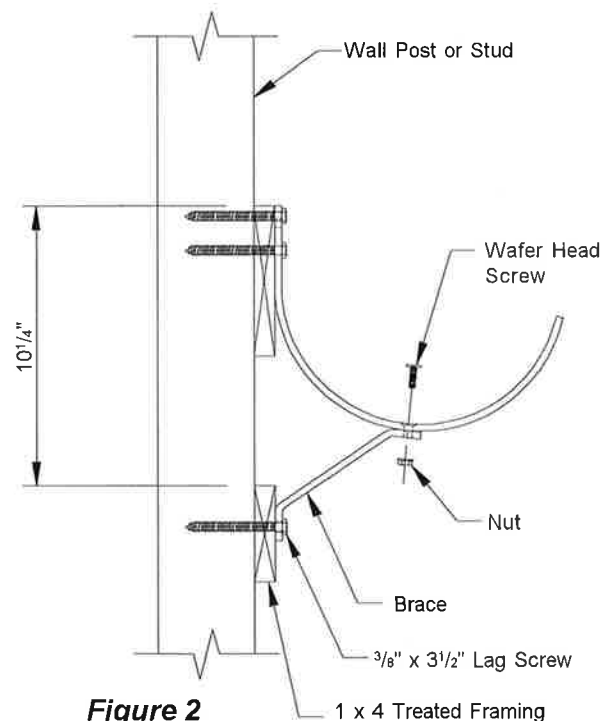

**Figure 2**