

USER'S MANUAL and INSTALLATION GUIDE

NOTE: If you have purchased the Center Tee Kit, EC1609, see Installation Instructions, QM1140.

TABLE OF CONTENTS

| <u>Section</u> | <u>Page</u> |
|--|-------------|
| Tools Required for Installation | 2 |
| Unpacking the Cooling System | 2-3 |
| Installation | 3-22 |
| Black Poly Tank | 10-11 |
| White Pipe Tank | 12-13 |
| Caulking | 16-18 |
| Plumbing | 23-27 |
| Black Poly Tank | 23-24 |
| White Pipe Tank | 25-27 |
| Flush Out Kit (EC1507) <i>purchased separately</i> | 27 |
| System Start-Up | 31 |
| System Operation and Adjustment | 31 |
| Maintenance | 32 |
| Maintenance Checklist | 32 |
| Warranty Statement | 32 |
| Exploded View and Parts List | 33-34 |

THANK YOU

Thank you for purchasing an Aerotech, A Munters Company, Evaporative Cooling System. Aerotech equipment is designed to be the highest performing, highest quality equipment you can buy. With the proper installation and maintenance it will provide many years of service.

PLEASE NOTE

*To achieve maximum performance and insure long life from your Evaporative Cooling System it is essential that it be **installed and maintained properly**. Please read all instructions carefully before beginning installation.*

TOOLS REQUIRED FOR INSTALLATION

| | | |
|----------------------------|----------------------------|----------------------|
| Caulk Gun | Hand Saw | Hack Saw |
| 5/16" Socket or Nut Driver | Clean Rags | 1 3/8" dia. hole saw |
| 3/8" Socket or Nut Driver | Electric or Cordless Drill | Phillips Screwdriver |
| 9/16" Socket or Nut Driver | Sharp Utility Knife | |
| 7/16" Wrench | Tape Measure | |

UNPACKING COOLING SYSTEM

Aerotech Evaporative Cooling Systems come in lengths from 5'L. to 80'L., sold in multiples of 5'L. and 10'L. modular sections. The ending kits, pumps, tank kits and plumbing kits will be packaged separately.

A CP10, CP20, CP30....CP70 and CP80 will arrive as multiples of 10'L. packages for the cooling frame and Ending Kit.

Example: CP60 Cooling System

- 6 - CN10, 10'L. Cooling Frame
- 1 - EC4110, Ending Kit
- 1 - Sealant box

A CP5, CP15, CP25....CP65 and CP75 will arrive as multiples of 10'L. packages and one 5'L. package and Ending Kit.

Example: CP65 Cooling System

- 6 - CN10, 10'L. Cooling Frame
- 1 - CN05, 5'L. Cooling Frame
- 1 - EC4110, Ending Kit
- 1 - Sealant box

If optional add on kits are ordered one or more extra box(s) marked CN02 or CN04 will be included.

Before beginning installation, check the overall condition of the equipment. Remove packing materials, and examine all components for signs of shipping damage. Any shipping damage is the customer's responsibility and should be reported immediately to the freight carrier.

Each CP System includes:

- 8" Pipe, PVC
- Drip Collector, PVC
- Drip Collector End Cap, PVC
- Distribution Cap, PVC
- Pad Retainer, PVC
- 1 1/2" Pipe with holes, PVC
- 1 1/2" Slip Cap, PVC
- 2 - End Panels, left / right, Plastic
- Pipe Support Brackets - supplied for 4' O.C. (see Chart A)
- 1 - Hardware Package
- 1 - Flush Out Kit (EC1507), purchased separately

NOTE: Tank Kits must be purchased with each 'CP' Cooling System.

| | |
|------------------------------|--------------------------|
| <u>Non-submersible pumps</u> | <u>Submersible pumps</u> |
| 10" Tank: EC1607 | 15" Tank: EC1606 |
| 15" Tank: EC1608 | 15" Tank: EC1609 |

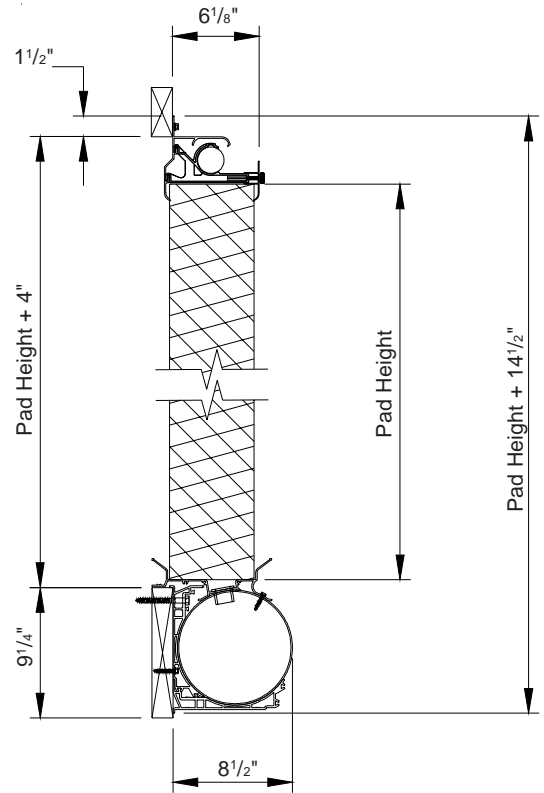

NOTE: If EC1609, Center Tee Tank Kit was purchased proceed to QM1140.

INSTALLATION INSTRUCTIONS

- 1) Construct a wall opening according to your cooling system size, with studs 2' O.C. or post 4' O.C. (max 5' O.C.). **See Figure 1.** (For example a CP36 with EC1115 would have an opening of 36' 1/2" L. x 64" H.).

| Catalog No. | Pad Height | Wall Opening Height |
|-------------|------------|---------------------|
| EC1101 | 24"H | 28"H |
| EC1102 | 36"H | 40"H |
| EC1103 | 48"H | 52"H |
| EC1115 | 60"H | 64"H |
| EC1104 | 72"H | 76"H |

Figure 1

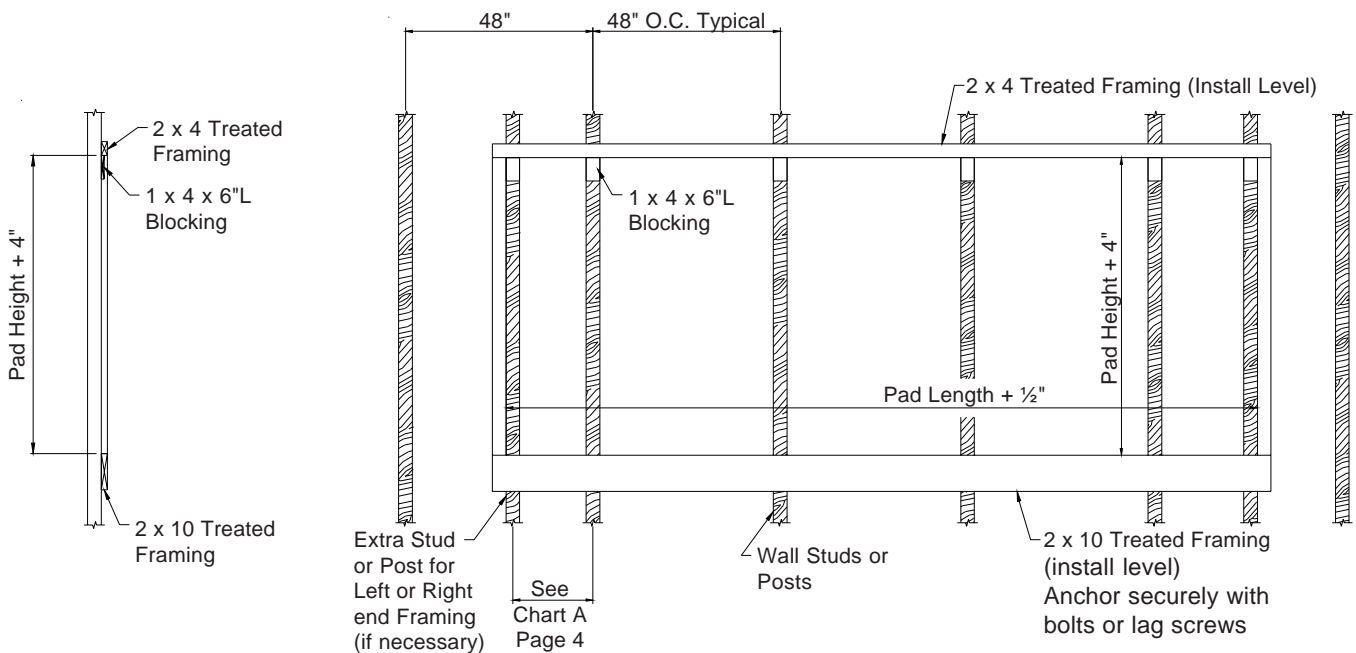

- 2) Some brackets are in the ending kit and some in the cooling kit. Find 2 halves of the pipe bracket, EC1330 and EC1328, and slide them together. **See Figure 2.**
- 3) For proper pipe support bracket spacing refer to **Chart A, Figures 3A and 3B.**

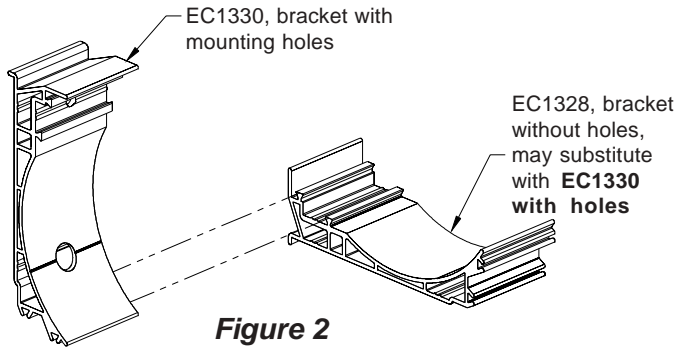

Figure 2

Chart A

| Length of Cooling System | No of Brackets Needed | Placement of Brackets* |
|--------------------------|-----------------------|------------------------|
| 4' | 2 | 2" |
| 5' | 2 | 12" |
| 6' | 2 | 12" |
| 8' | 3 | 2" |
| 10' | 3 | 12" |
| 12' | 4 | 2" |
| 14' | 4 | 12" |
| 15' | 5 | 2" |
| 16' | 5 | 2" |
| 18' | 5 | 12" |
| 20' | 6 | 2" |
| 22' | 6 | 12" |
| 24' | 7 | 2" |
| 25' | 7 | 12" |
| 26' | 7 | 12" |
| 28' | 8 | 2" |
| 30' | 8 | 12" |
| 32' | 9 | 2" |
| 34' | 9 | 12" |
| 35' | 10 | 2" |
| 36' | 10 | 2" |
| 38' | 10 | 12" |
| 40' | 11 | 2" |
| 42' | 11 | 12" |
| 44' | 12 | 2" |
| 45' | 12 | 12" |
| 46' | 12 | 12" |
| 48' | 13 | 2" |
| 50' | 13 | 12" |
| 52' | 14 | 2" |
| 54' | 14 | 12" |
| 55' | 15 | 2" |
| 56' | 15 | 2" |
| 58' | 15 | 12" |
| 60' | 16 | 2" |
| 62' | 16 | 12" |
| 64' | 17 | 2" |
| 65' | 17 | 12" |
| 66' | 17 | 12" |
| 68' | 18 | 2" |
| 70' | 18 | 12" |
| 72' | 19 | 2" |
| 74' | 19 | 12" |
| 75' | 20 | 2" |
| 76' | 20 | 2" |
| 78' | 20 | 12" |
| 80' | 21 | 2" |

IMPORTANT!
The tee and cap must be evenly setting on the ground or supported securely on a level surface.

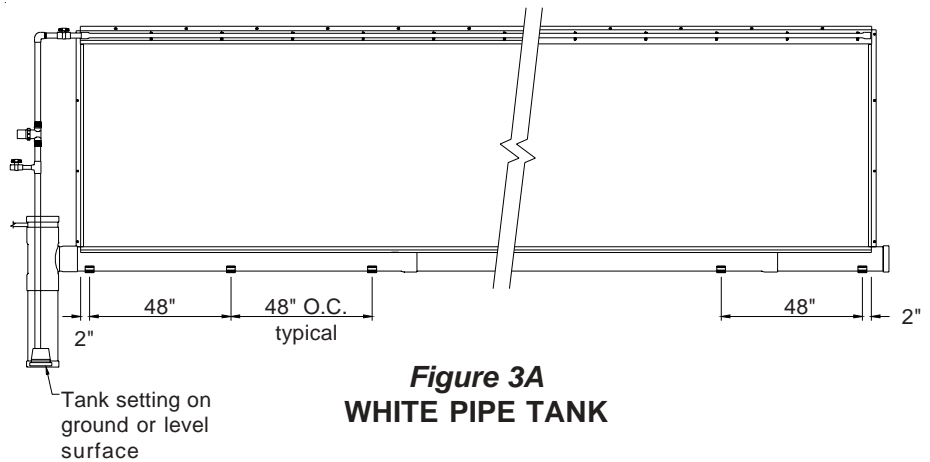

Figure 3A
WHITE PIPE TANK

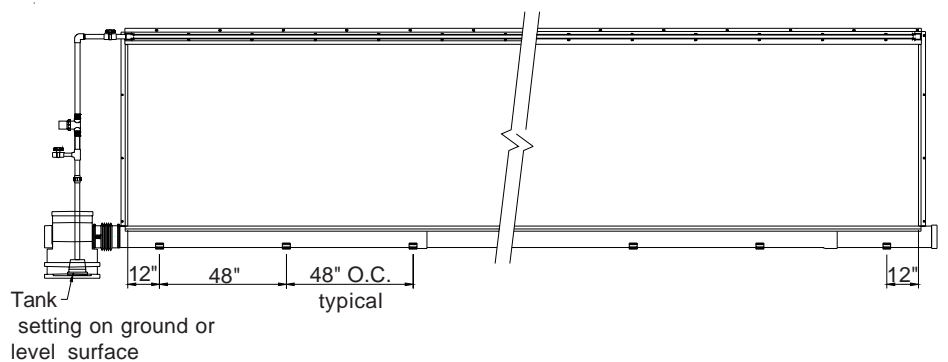

Figure 3B
BLACK POLY TANK

- 4) At the bottom framing fasten the pipe support bracket to the 2 x 10 at each post (stud) according to the proper spacing on **Chart A**. Make sure the lip of the pipe support bracket hangs on the top of the 2 x 10. The top hole of the pipe support bracket should be secured with a $\frac{3}{8}$ " x $3\frac{1}{2}$ " Lag screw (provided). Pre-drill framing for $\frac{3}{8}$ " Lag screws using $\frac{1}{4}$ " drill bit. The bottom hole should be fastened with a #14 x $1\frac{1}{2}$ " Lag screw (provided). **See Figure 4A, 4B and 4C**. If framing does not match Figure 4A, framing must be capable of supporting 300 lbs. per bracket.

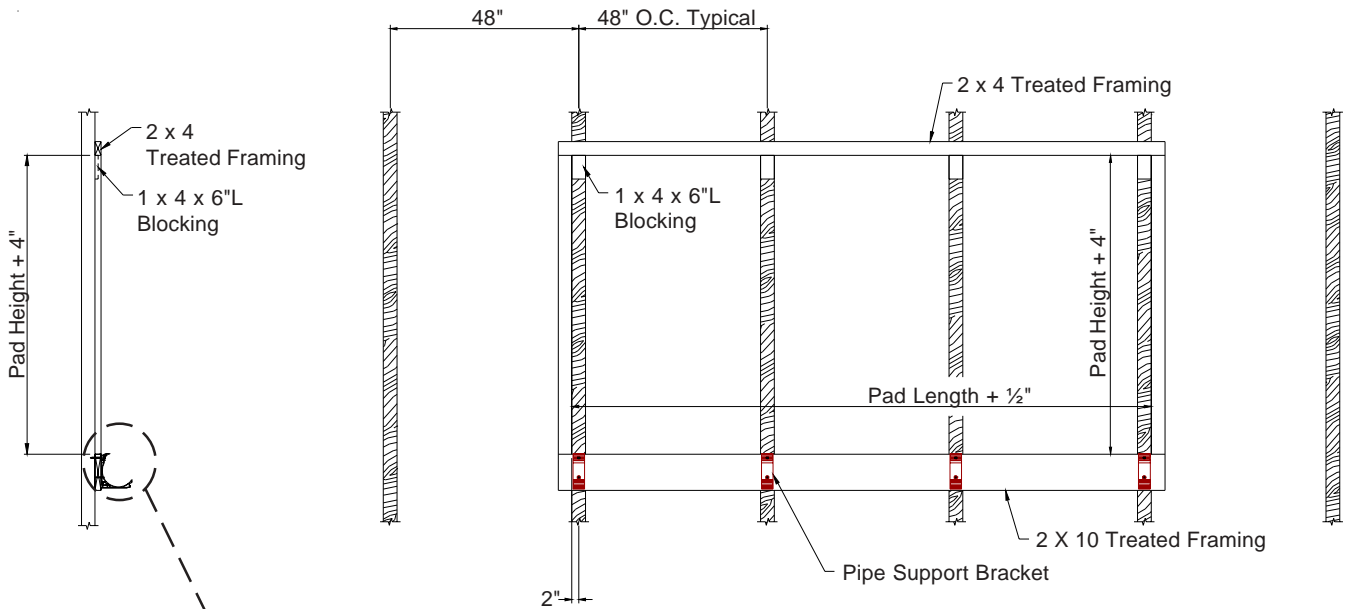

Figure 4A

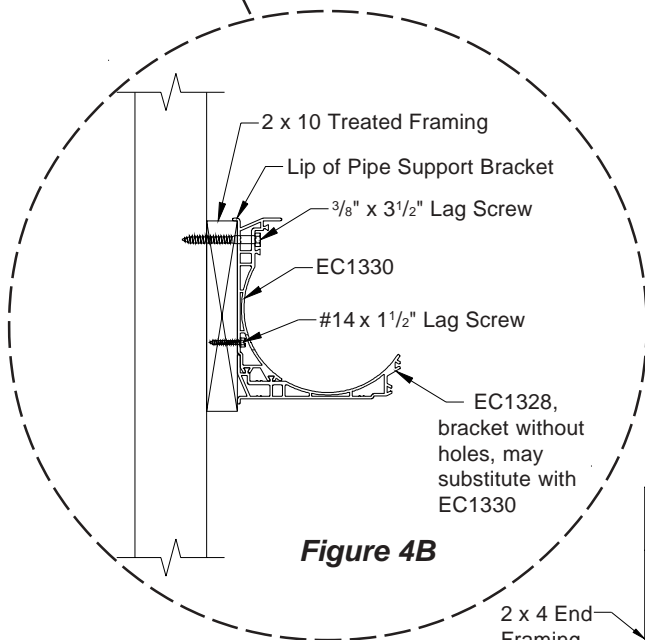

Figure 4B

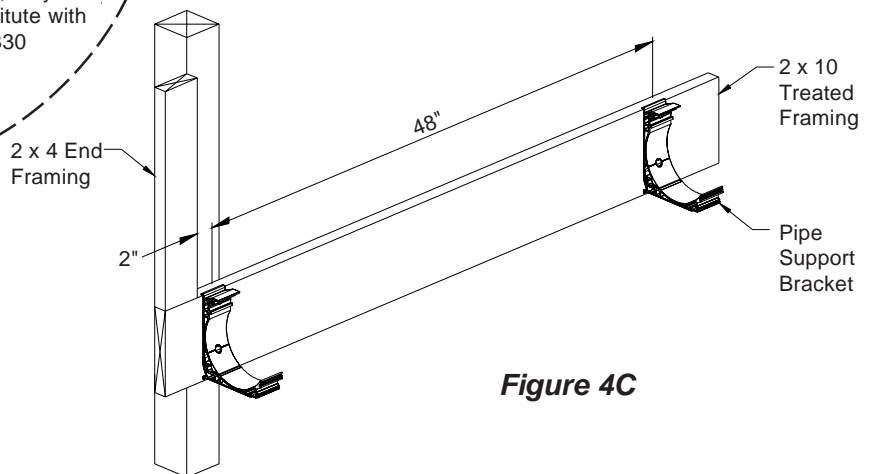

Figure 4C

5) Starting on the end that the tee will mount on, position first 2 sections of 8" pipe in pipe support brackets. Prepare the pipe with PVC Pipe Primer, following directions of use and drying. After priming, use heavy duty, heavy bodied PVC cement for pipe 8" diameter or larger, in accordance to the PVC cement directions.

6) Apply a generous amount of PVC cement to the inside of the belled end, and the outside of the male end, and slide together, 5" deep. **See Figure 5A.** Continue for all sections of 8" pipe.

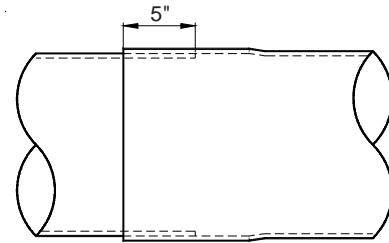

Figure 5A

7a) On the end that the tee will mount extend the 8" pipe 4" past the edge of the framed opening. **See Figure 5B.**

7b) On end opposite the tee, cut the 8" pipe off 4" past the framed opening. **See Figure 5B.**

8) Set the first drip collector on the 8" pipe, leaving a 1/8" gap between edge of frame opening and drip collector. Place a level across drip collector flanges and level drip collector front to back. **See Figure 6A.**

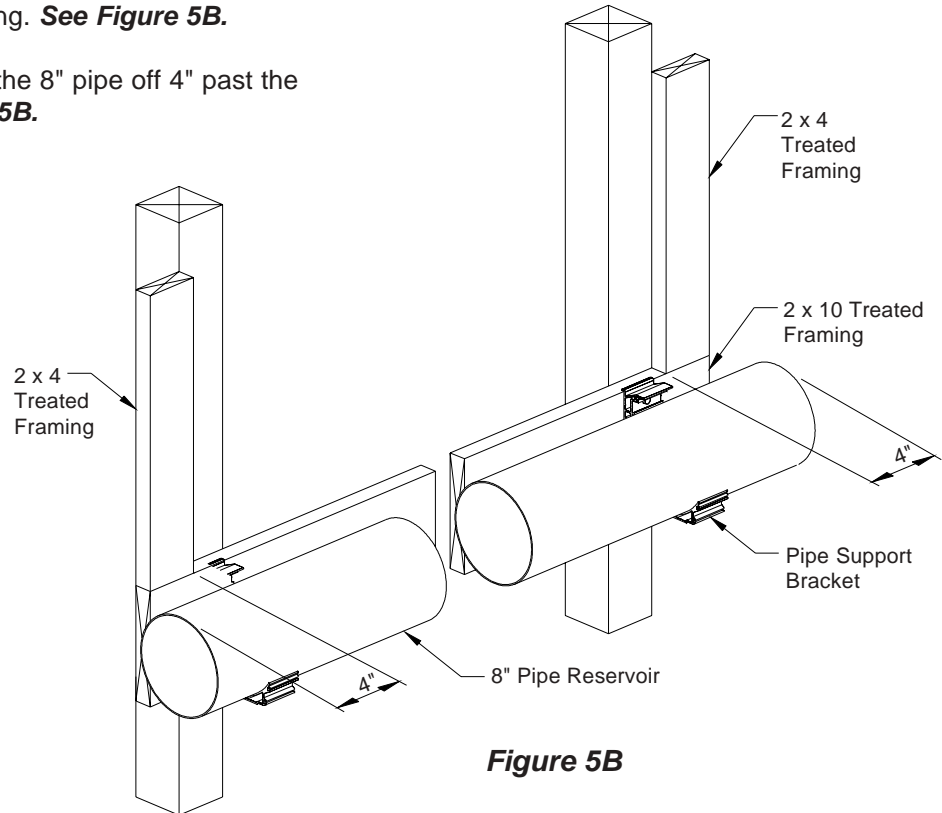

Figure 5B

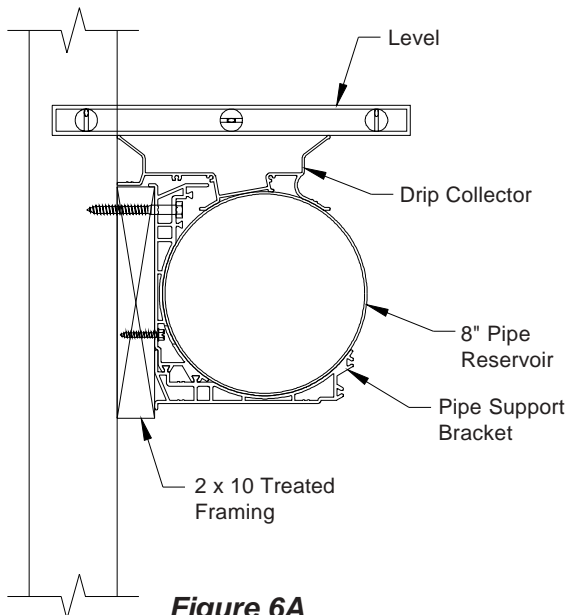

Figure 6A

- 9) Carefully lift end of drip collector off 8" pipe. Prime and PVC cement a 3" wide area on 8" pipe, at both ends of collector. Replace drip collector on the 8" pipe, keeping it level. Fasten each end of collector to 8" pipe using (1) #10 x 1/4" TEK screw located 4" from each end. **See Figure 6B and 6C.**

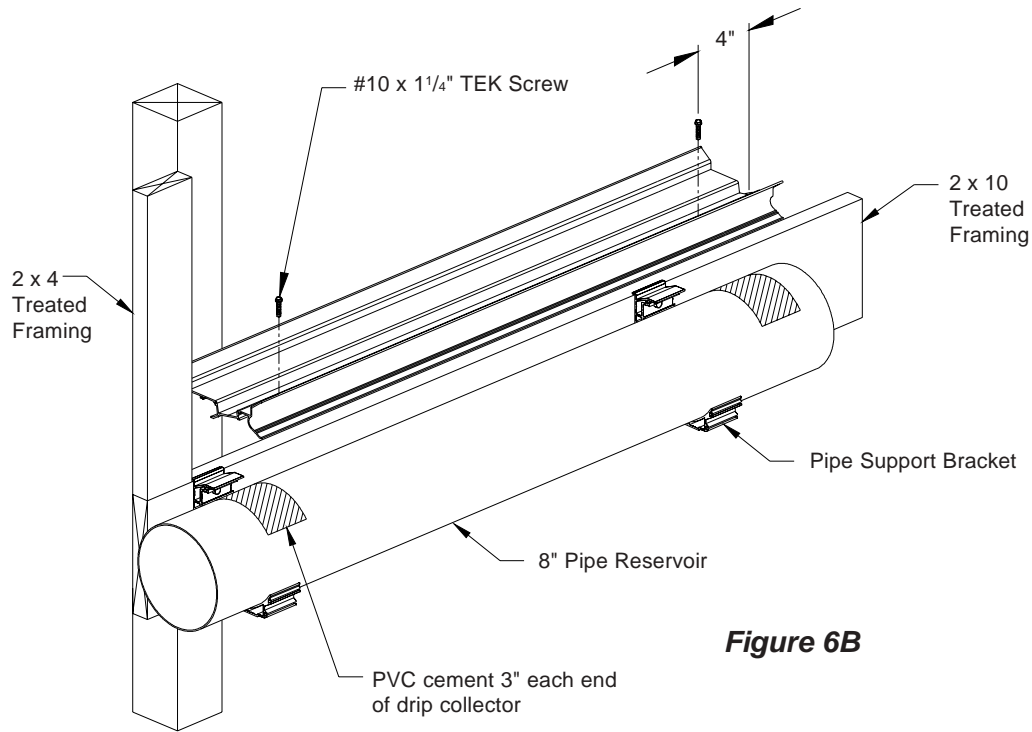

Figure 6B

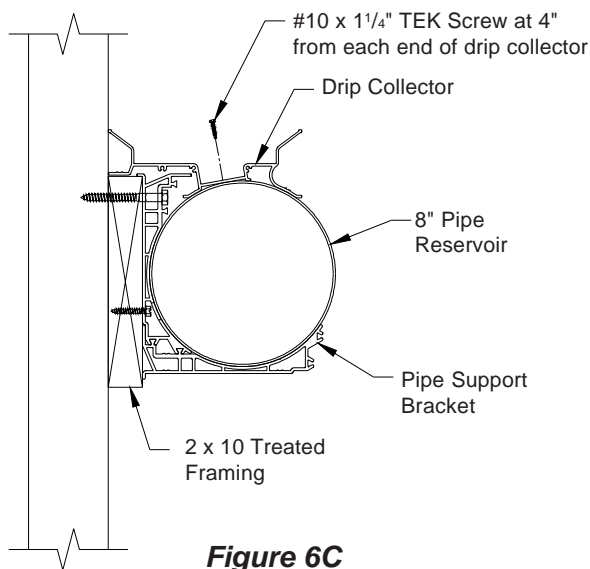

Figure 6C

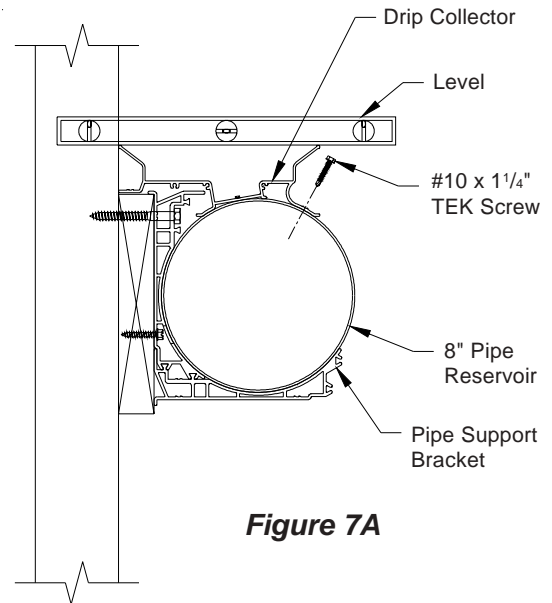

Figure 7A

- 10a) Starting 2" from left end of the drip collector, keeping drip collector level, fasten to 8" pipe using #10 x 1/4" TEK screw (provided). Continue fastening drip collector to 8" pipe using #10 x 1/4" TEK screws at 16" O.C., use the V-groove as a guide. **See Figures 7A and 7B.**

10b) Continue placing drip collectors down length of pipe by leveling, priming, cementing and fastening drip collectors to 8" pipe. Be sure to push drip collectors tight together. **See Figure 7B.**

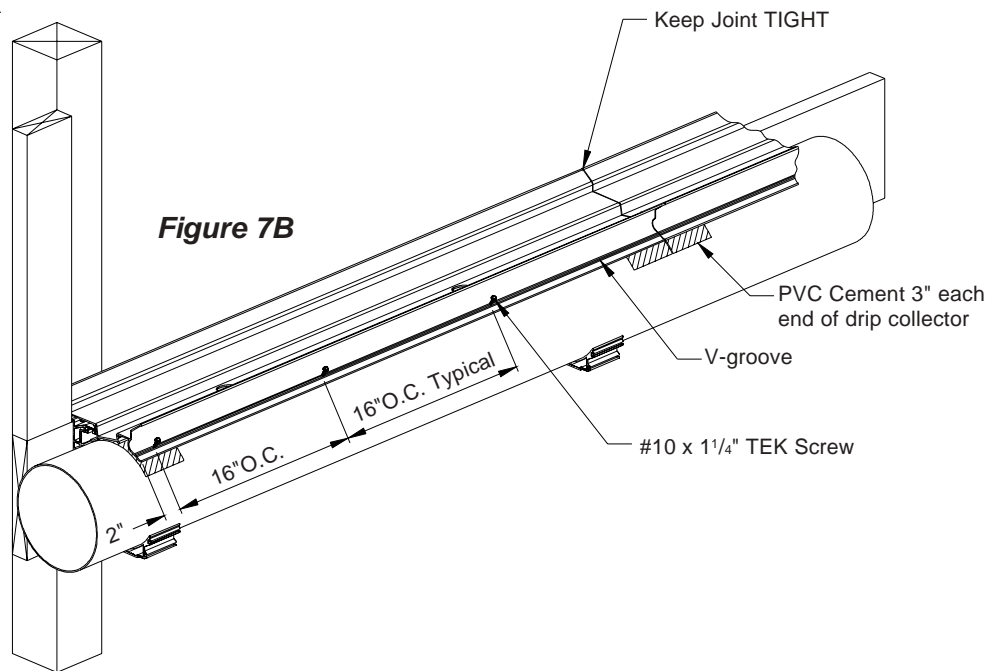

Figure 7B

10c) Prime and PVC cement drip collector 3" on each side of joint. Center splice over joint in drip collector and fasten in place using (6) #10 x 1/4" TEK screws. Locate (2) in bottom of splice and (2) on each flange. **See Figures 7C and 7D.**

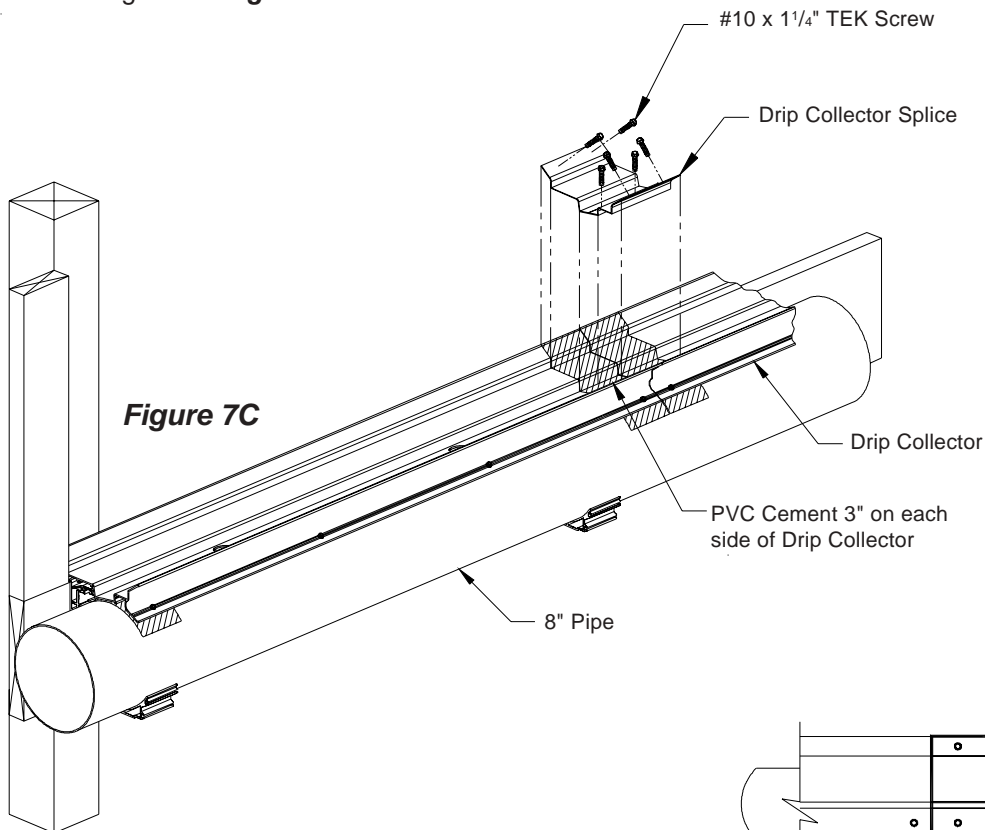

Figure 7C

Refer to Step 14 for caulking procedures.

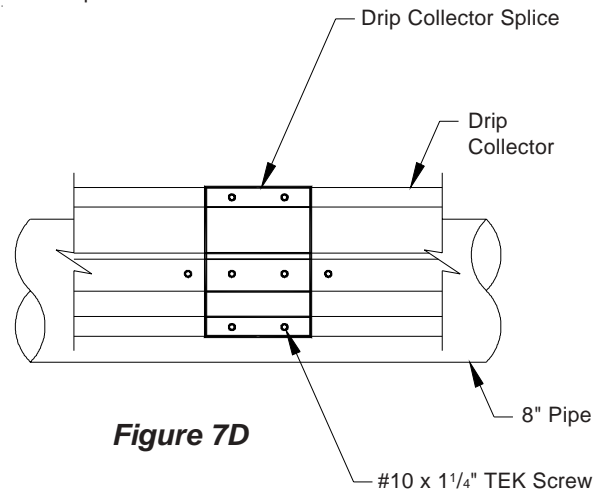

Figure 7D

- 11) Starting 12" from end of drip collector, use a 1^{3/8}" dia. hole saw and drill a hole through the drip collector and 8" pipe every 24" O.C. Make sure not to leave plugs from drilling hole in the pipe. PVC cement drain fitting, into hole. **See Figures 8A and 8B.**

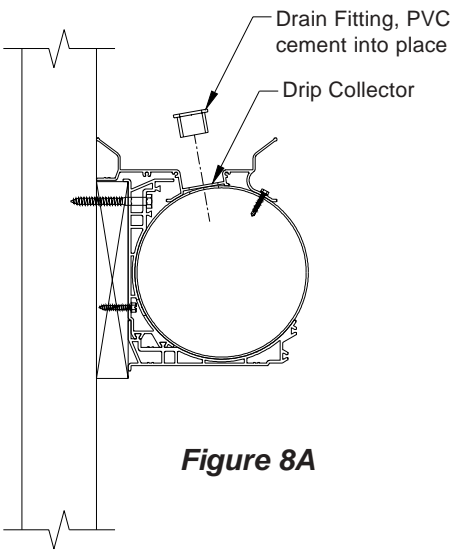

Figure 8A

! WARNING
Remove all shavings from inside the pipe and from the top of drip collector.

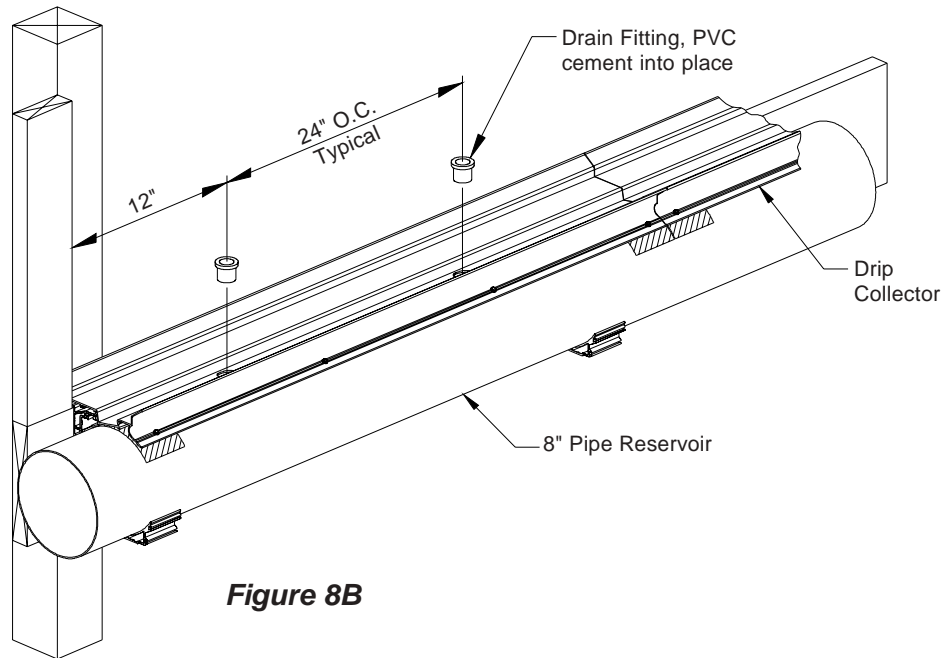

Figure 8B

For Black Poly Tank proceed to Step 12a. For White Pipe Tank proceed to Step 13a.

Black Poly Tank:

- 12a) Prepare the black poly tank for attachment to the 8" pipe by removing the flat interior surface of the 8" pipe area, cut the flat end leaving a minimum of 1/4" lip around the edge, **See Figure 9A. DO NOT CUT** the outer surface of the 8" pipe area, cutting the round surface will weaken the tank structure. **See Figure 9A.**

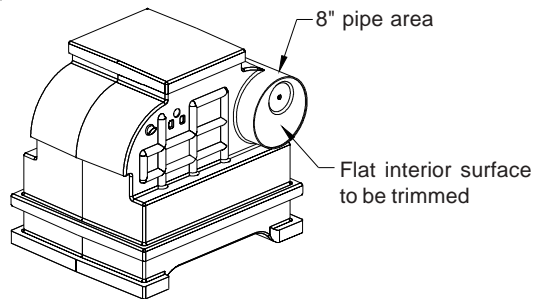
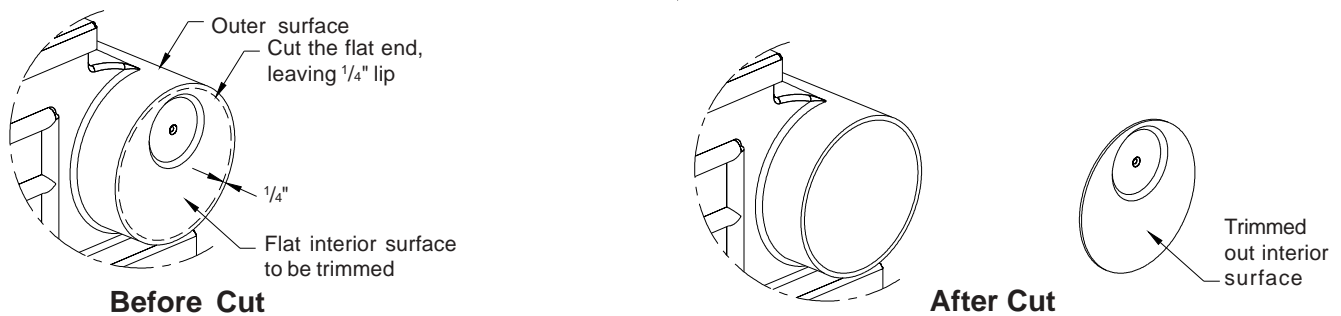

Figure 9A



- 12b) Slide the rubber bellow connector over the 8" pipe and the other end over the black poly tank. Be sure the drip collector remains on top of the 8" pipe. Secure in place with hose clamps positioned in the grooves of the rubber bellow connector. Install the 8" rubber cap on the 8" pipe end opposite the tank. **See Figures 9B through 9D.**

NOTE: In some installations it may be necessary to bury or elevate the black poly tank for proper alignments with the 8" pipe; in either case the ground or other support must be capable of supporting 300 lbs. If using the optional 'EC1630, Cooling Tank Drain Kit-below grade' install at this time following the instructions provided with the kit.

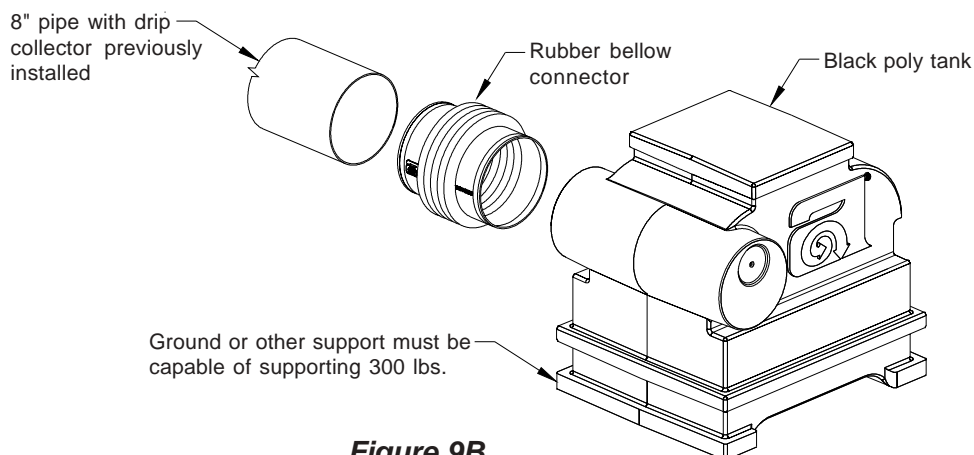
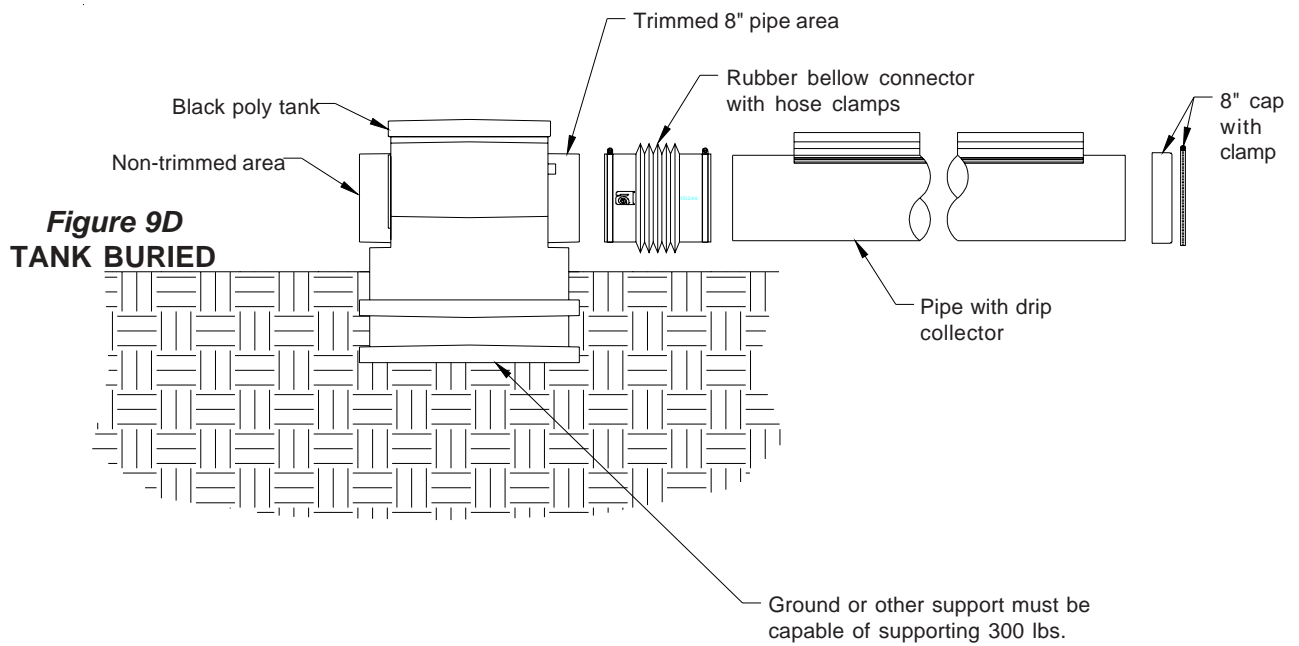
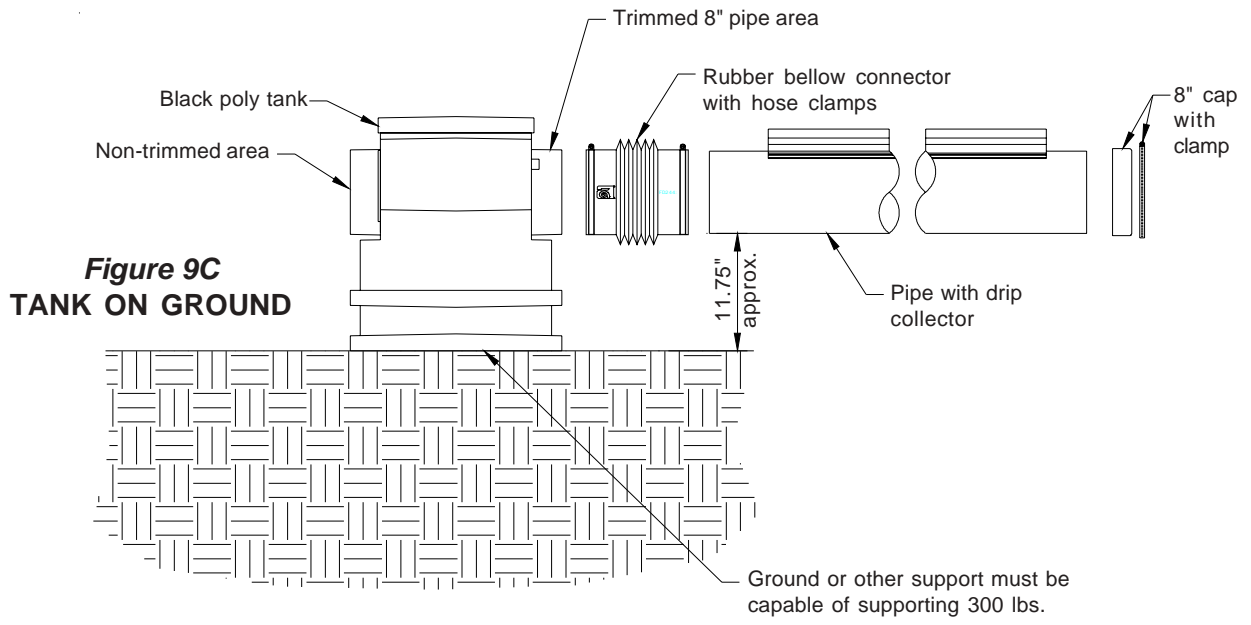

Figure 9B



White Pipe Tank:

13a) Prepare the tee, pipe nipples and pipe cap in accordance to PVC primer and cement directions and assemble the (2) pipe nipples, tee and pipe cap. **See Figure 10A.** For completed assembly, **See Figures 10B and 10C.**

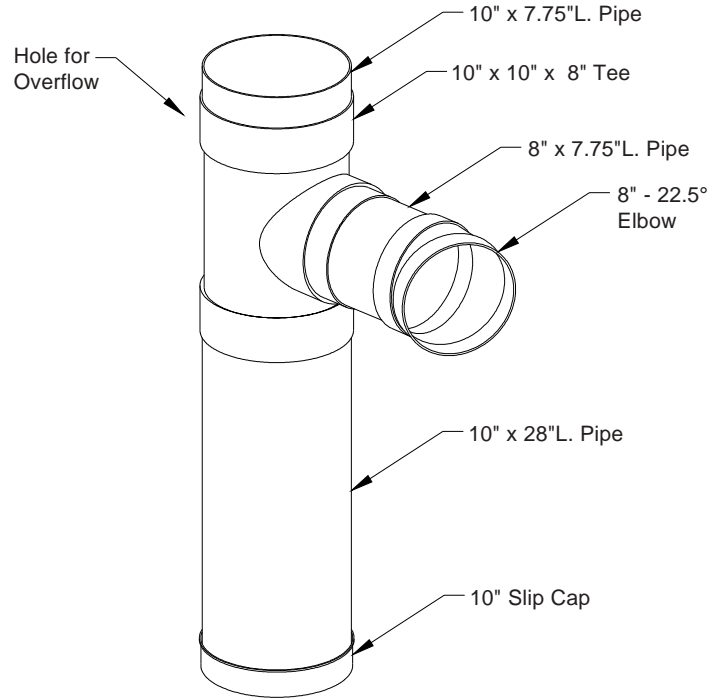
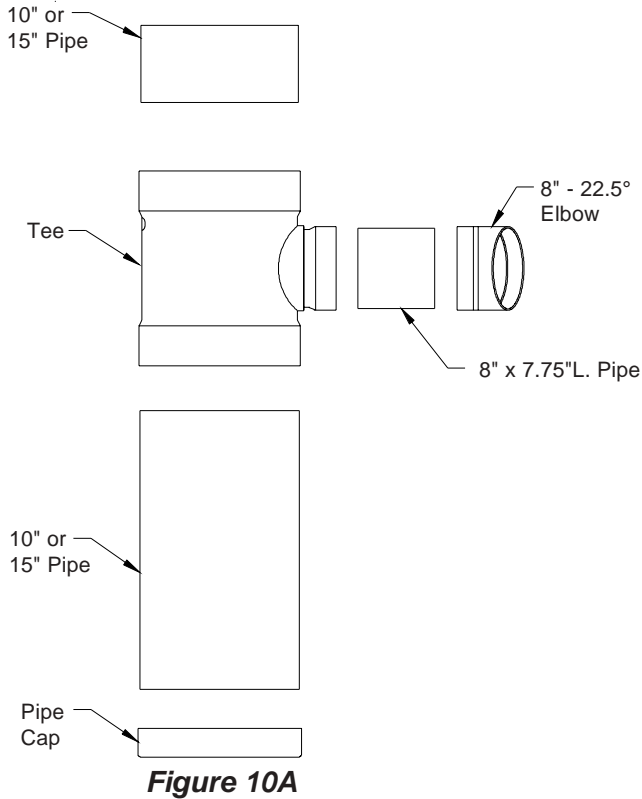

Figure 10B
EC1607, 10" TANK KIT
(COMPLETED)

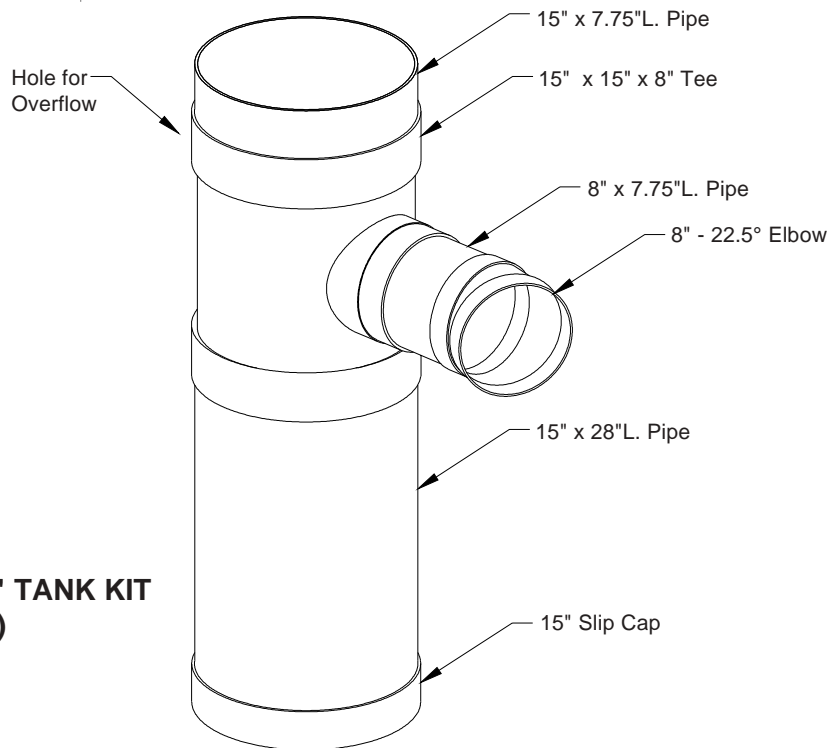
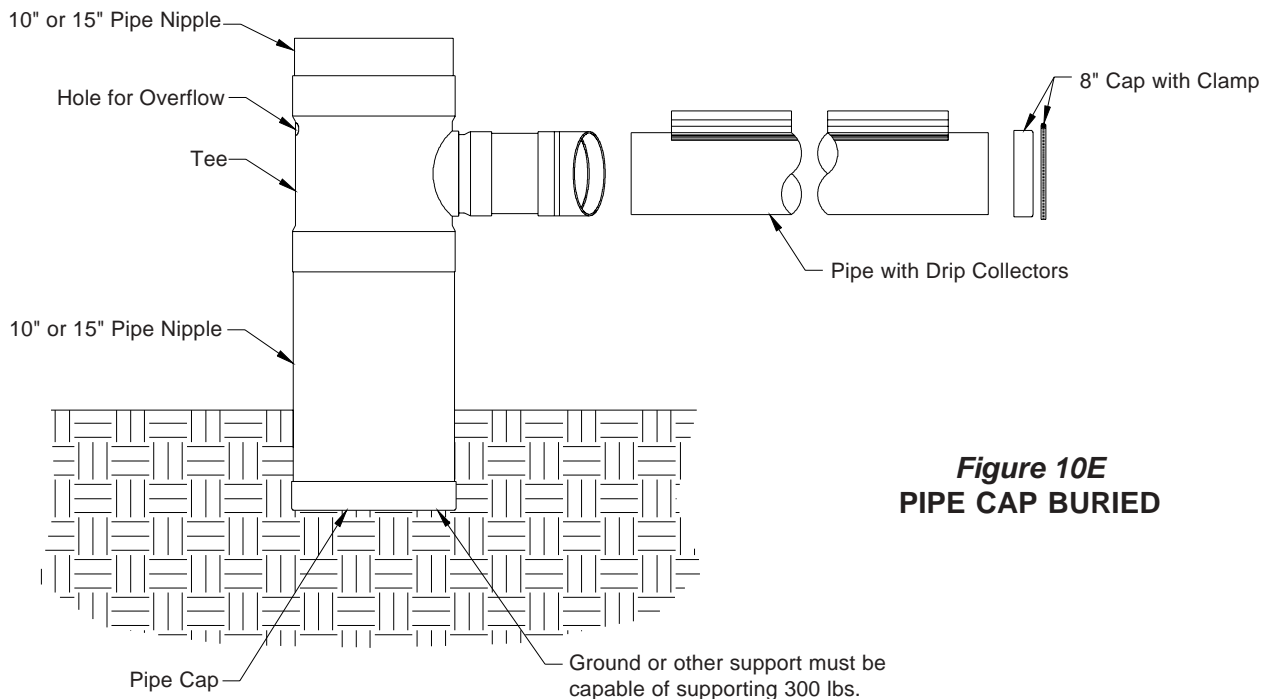
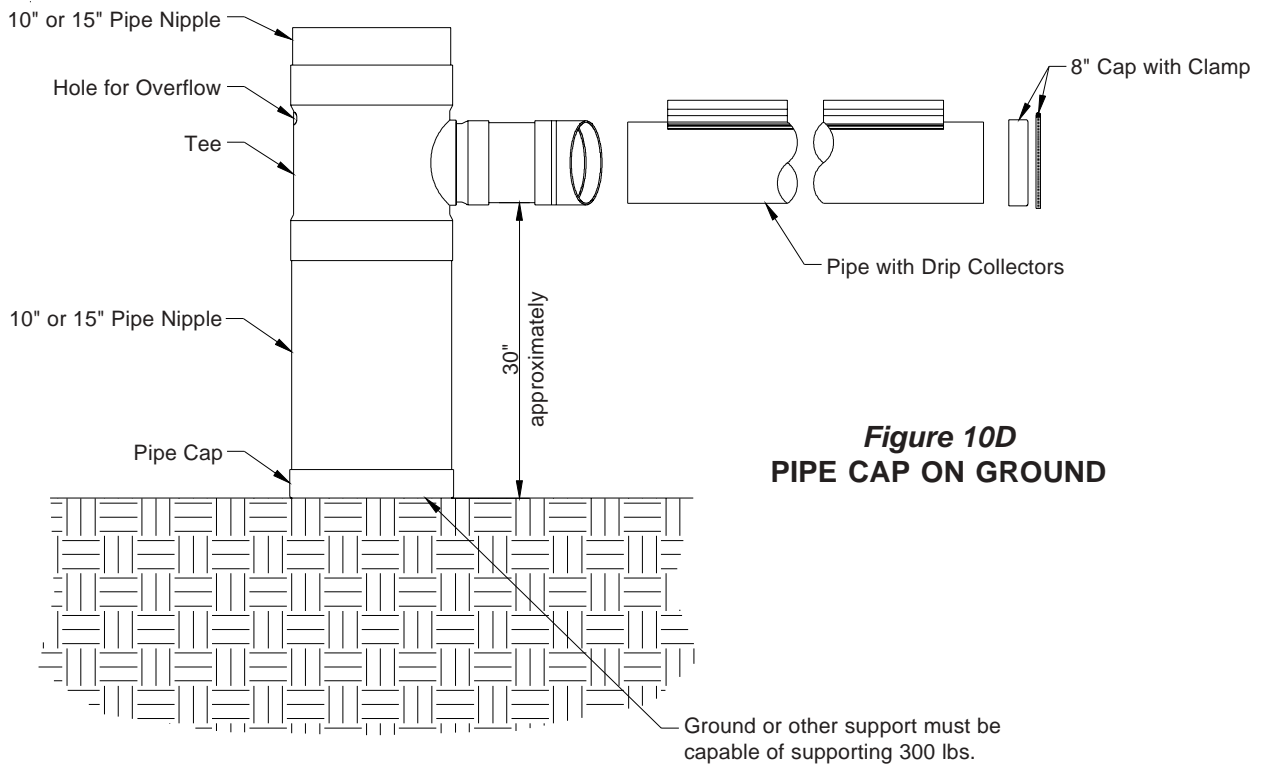

Figure 10C
EC1606 AND EC1608, 15" TANK KIT
(COMPLETED)

- 13b) Once the PVC cement has dried use primer and cement and assemble the tee fully onto pipe. Be sure the drip collectors remain on top and the tee is straight up and down. When tee is completely installed the 28"L. pipe nipple with cap may need to be buried so that when together, it rests on the ground or another support. **See Figures 10D and 10E.** Install 8" cap on end of pipe opposite tee.

Note: If using the optional cooling tank drain kit-below grade (EC1630), install at this time following the instructions provided with the kit.



- 14a) Determine the height of your cooling system and cut the end panels down to the correct length according to **Chart B**. Trim the end panels as indicated below. Determine which end panel will be at the end with the water supply and drill a 2" - 2¹/₄" dia. hole 1⁷/₈" from top, as shown. If the EC1507 Flush-Out Kit was purchased, then drill a 2" - 2¹/₄" dia. hole in the other end panel also. **See Figure 11A and 11B.**

| Pad Height | Length of End Panel |
|------------|----------------------------------|
| 24"H | 27 ¹ / ₄ " |
| 36"H | 39 ¹ / ₄ " |
| 48"H | 51 ¹ / ₄ " |
| 60"H | 63 ¹ / ₄ " |
| 72"H | 75 ¹ / ₄ " |

Chart B

**Figure 11A
LEFT END PANEL**

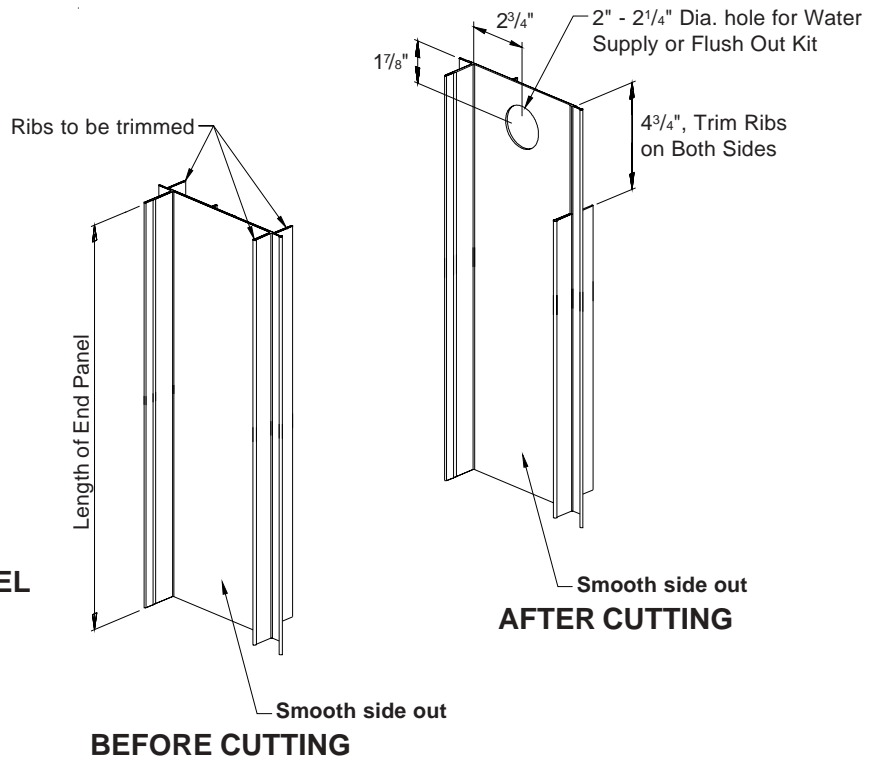

NOTE: Smooth side of end panel is the outside of system (Figure 11A). Grooved side of end panel is facing the pad (Figure 11B).

**Figure 11B
RIGHT END PANEL**

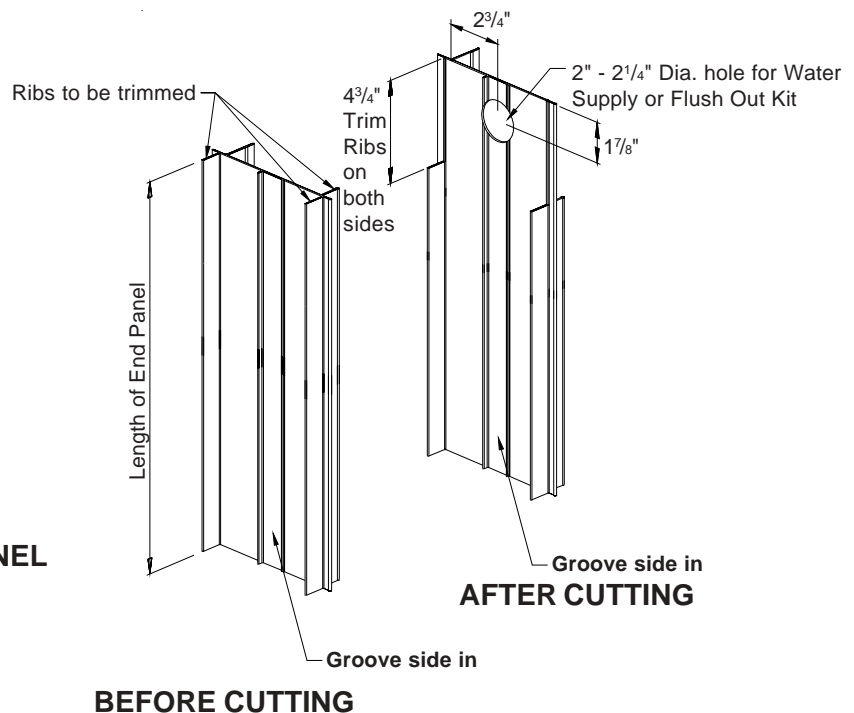

- 14b) Apply PVC cement to left end of drip collector. On left side of system line up the 3 holes in the drip collector end cap to the 'U' Channels in the drip collector, fasten using (3) #10 x 1/4" TEK screws (provided). **See Figure 11C.**
- 14c) Slide left end panel into framing and into drip collector on left end. End panel should fit snug, make sure ribs sit down tight into the drip collector. Fasten the last 2 screws into the drip collector end cap using (2) #10 x 1/4" TEK screws. **See Figure 11E.**
- 14d) Hold the end panel tightly against the framing and attach end panel to framing using #10 x 1/4" TEK screws (provided), **See Figure 11D. See Chart C** for spacing and number of Lag screws provided.

| Pad Height | No. of Screws | Spacing | Spacing top to first screw |
|------------|---------------|---------|----------------------------|
| 24"H | 1 | 24"O.C. | 2" |
| 36"H | 2 | 18"O.C. | 2" |
| 48"H | 2 | 24"O.C. | 2" |
| 60"H | 3 | 20"O.C. | 2" |
| 72"H | 3 | 24"O.C. | 2" |

Chart C

NOTE: Bottom lag screw will be between 20" -25" from bottom of end panel.

⚠ WARNING
 PVC cement must be completely dried before filling system with water. Failure to do so may result in pipe and tee sections coming apart.

Figure 11C

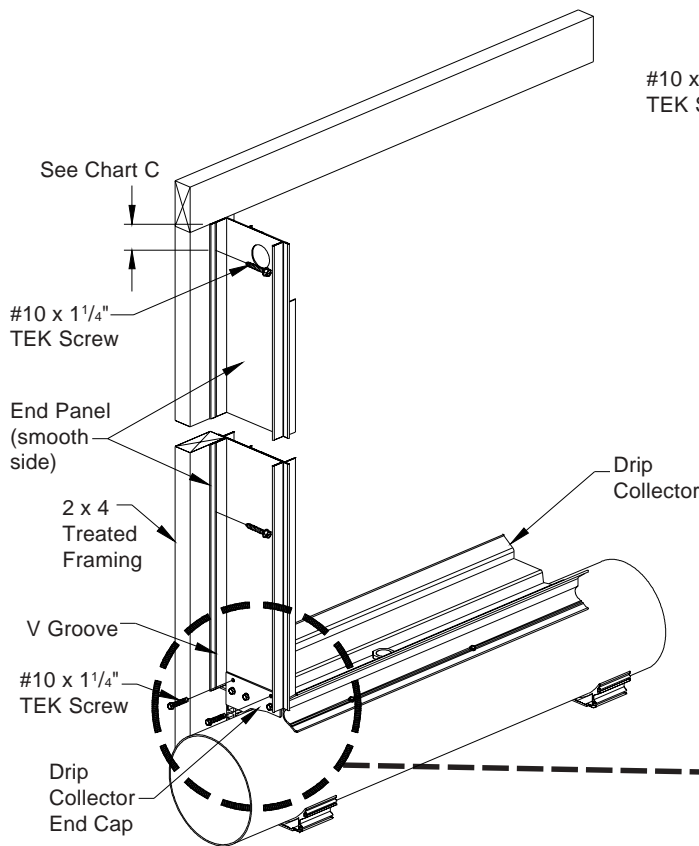
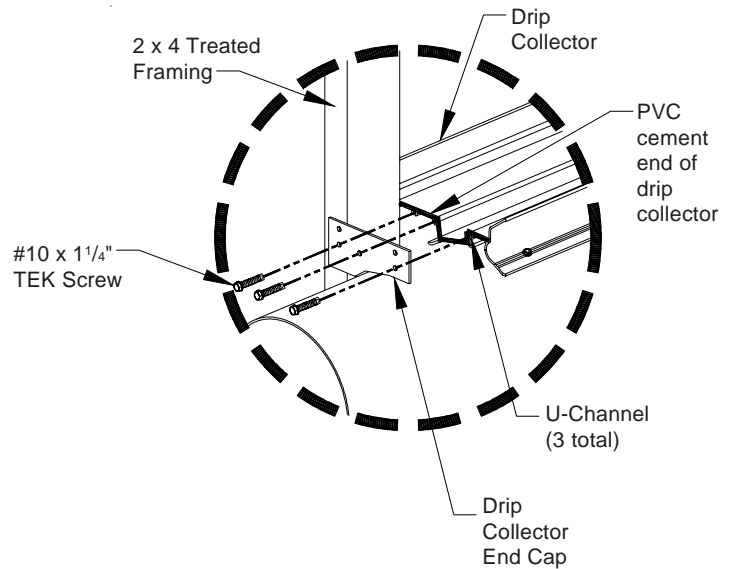

Figure 11D

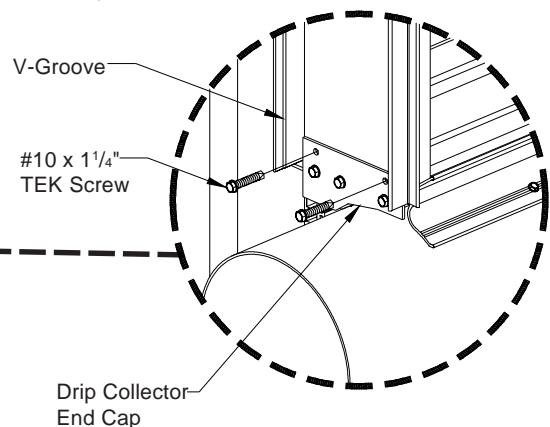

Figure 11E

15a) Using caulk provided, start at left end and caulk inside and outside of end panel and drip collector end cap where they meet drip collector and 8" pipe. Also caulk the screw head in bottom of drip collector and screws coming thru end panel. **See Figure 12A & 12B.**

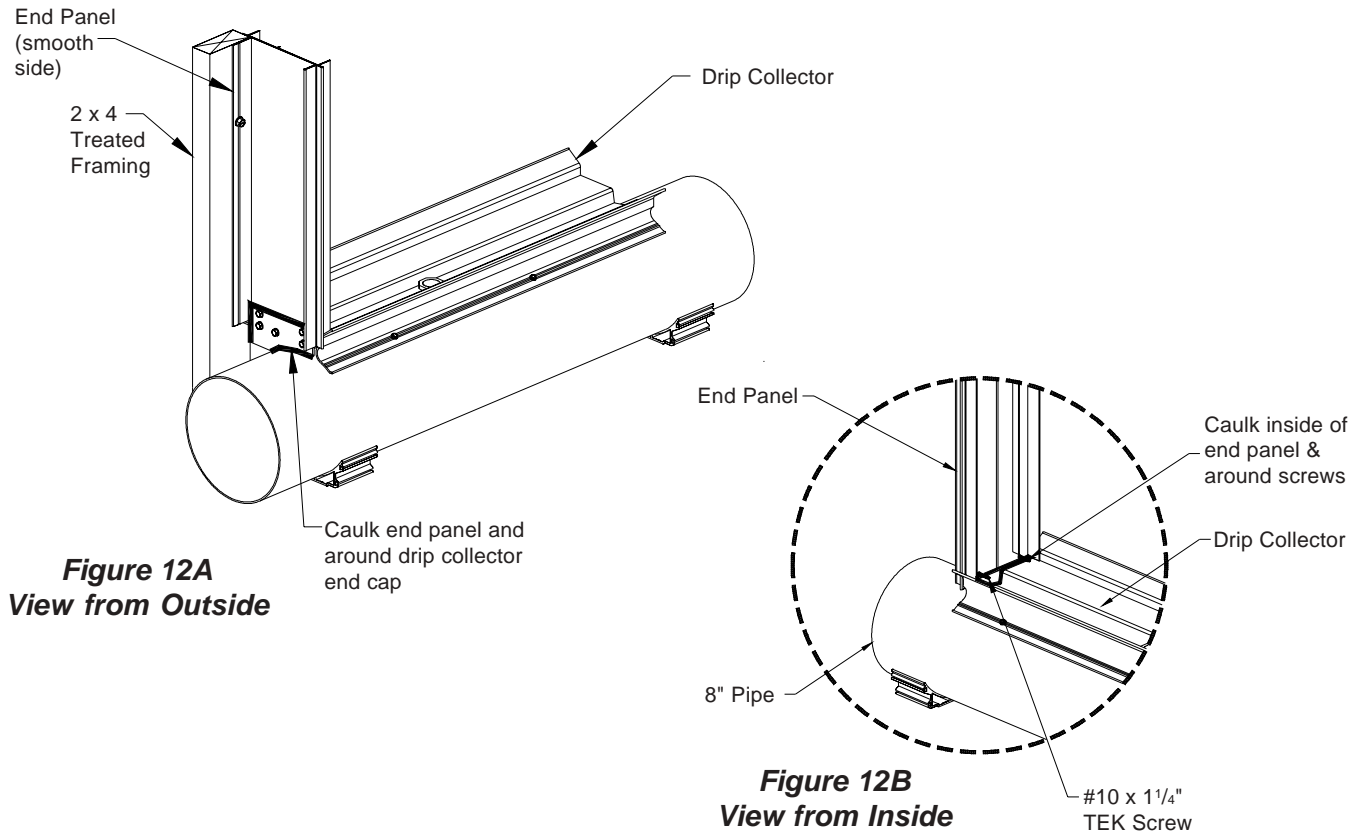

Figure 12A
View from Outside

Figure 12B
View from Inside

15b) Working down the length of the cooling, apply a wide bead of caulk at each edge of drip collector splices. Be sure to form caulk around all surfaces and over TEK screws. Caulk over TEK screws should be at least 1/4" diameter in size. Apply a bead of caulk around each drain fitting in drip collector. **See Figure 12C.**

15c) Refer to Step 18 for further caulking of distribution cap and right end panel.

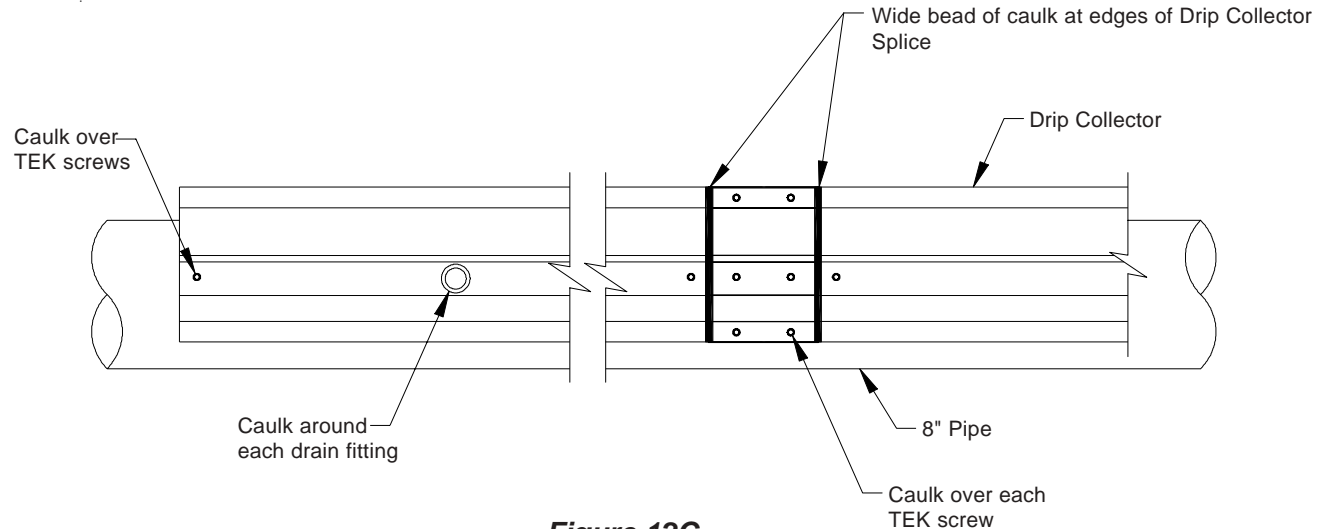

Figure 12C
VIEW FROM ABOVE

- 16) Attach distribution cap to left end of framed opening using #14 x 1 1/2" Lag screws and bushings. **DO NOT** tighten Lag screw against distribution cap. Distribution cap should be able to slide back and forth along slot to allow for contraction and expansion. Be sure to hold distribution cap tight against framing and that the Lag screws go in square so as not to tip cap upward. **See Figures 13A, 13B and 13C.** Repeat Step 15, leaving a 1/4" gap between sections, until you have installed all distribution caps.

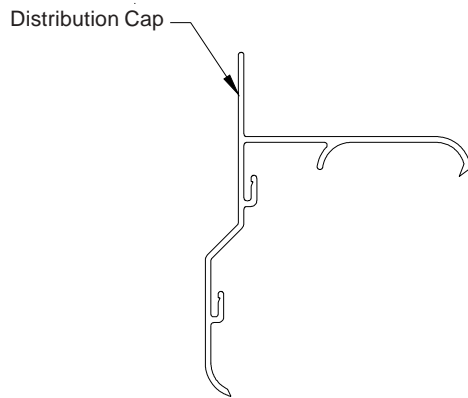

Figure 13A

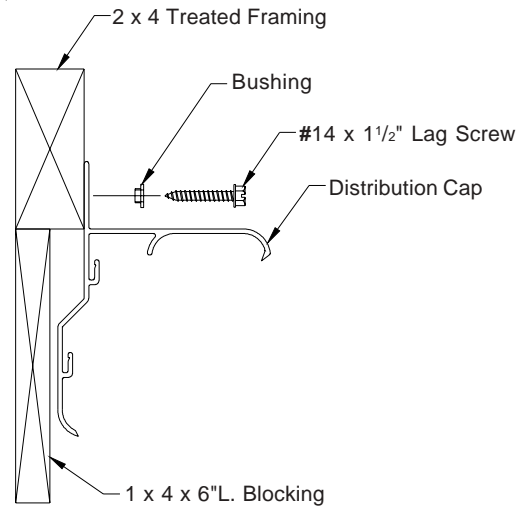

Figure 13B

! IMPORTANT
 Distribution cap must be able to slide in slot. **DO NOT OVER TIGHTEN** lag screws. Install similar to vinyl siding.

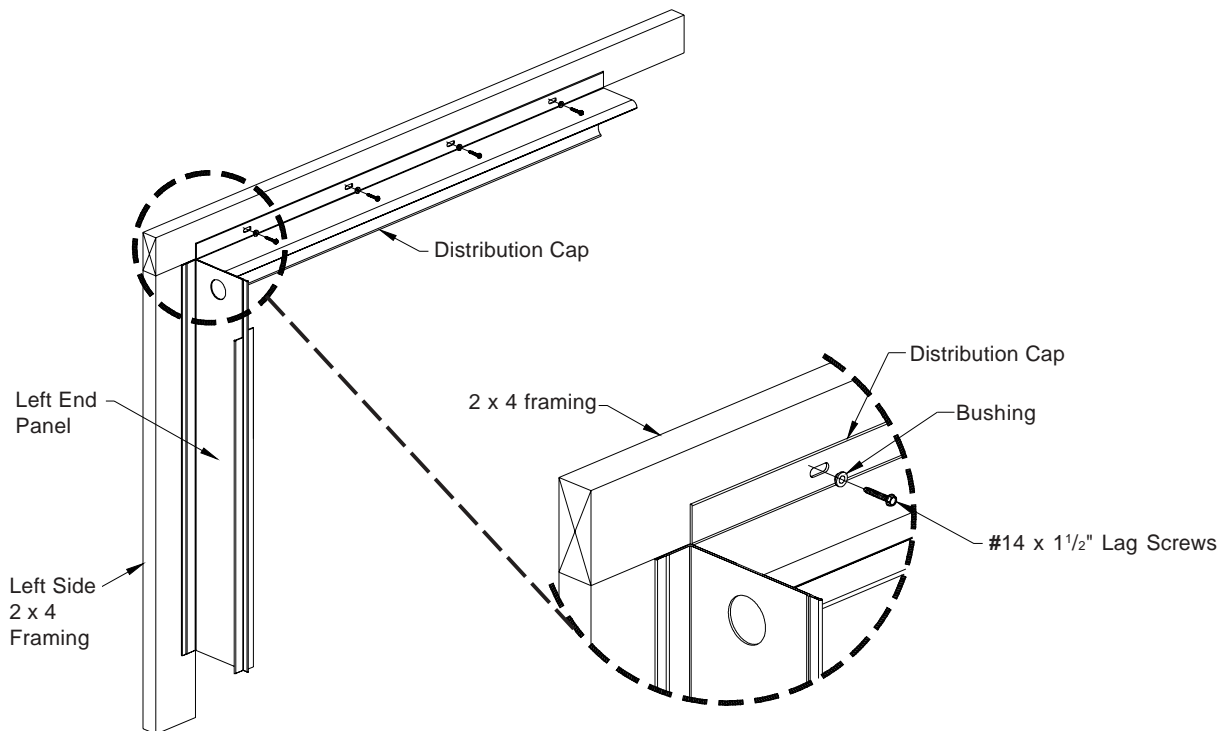

Figure 13C

17a) On right side of system apply PVC cement to end of drip collector and line up the 3 holes in the drip collector end cap to the 'U' Channels in the drip collector, fasten using (3) #10 x 1/4" TEK screws (provided). **See Figure 13D.**

17b) Slide right end panel into framing and into drip collector on right end. End panel should fit snug, make sure ribs sit down tight into the drip collector. Fasten the last 2 screws into the drip collector end cap using (2) 10 x 1/4" TEK screws. **See Figure 13D.**

17c) Hold the end panel tightly against the framing and attach end panel to framing using #10 x 1/4" TEK screws (provided), **See Figure 13E.** **See Chart C, page 13** for spacing and number of Lag screws provided.

18) Apply a bead of caulk around inside and outside of end panel and drip collector end cap where the end panel meets the drip collector and 8" pipe. **See Figure 13F.** Also caulk the screw head in bottom of drip collector and screws coming in thru end panel.

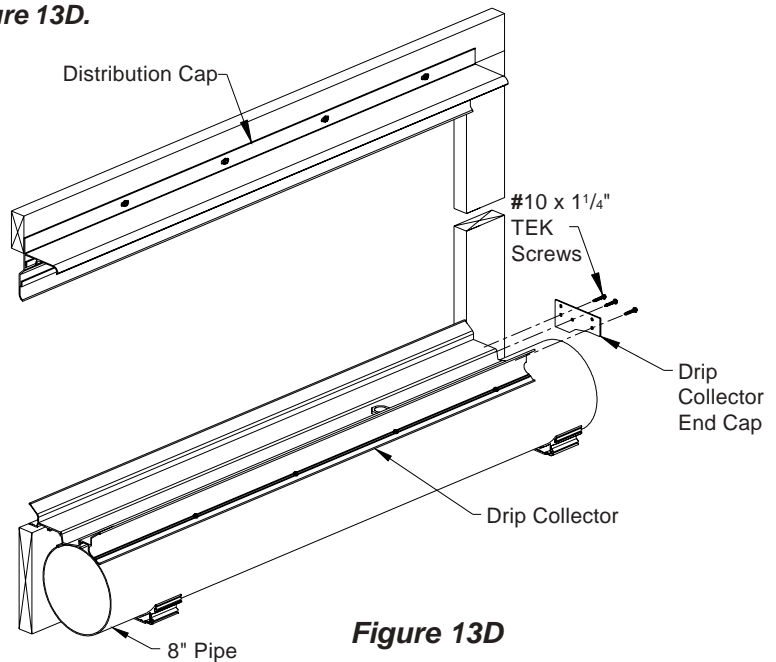

Figure 13D

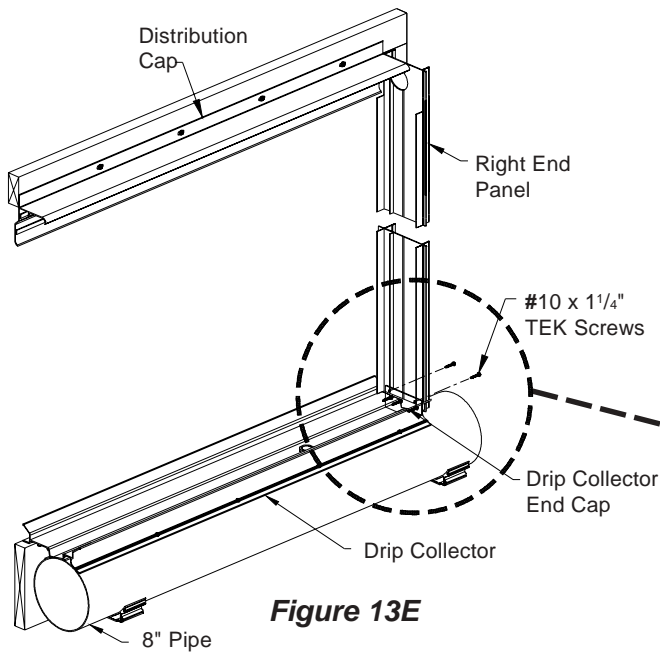

Figure 13E

IMPORTANT!
Recheck all caulk joints, before proceeding, to insure everything is sealed. Add caulk if necessary.

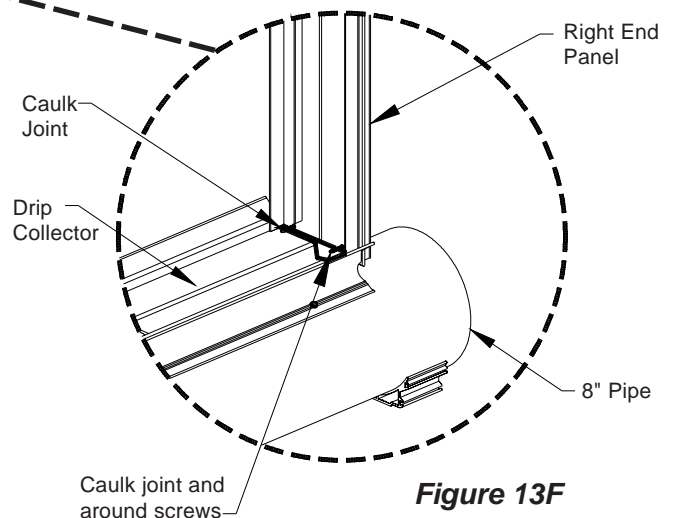

Figure 13F

- 19) Pipe supports snaps onto distribution cap, starting 12" from end, spaced every 24". **See Figure 14A.** Five (5) pipe support brackets per 10' section of distribution cap. Pipe supports can be slid back and forth for proper alignment.
- 20) Snap pipe into pipe supports, **See Figures 14B & 14C.** The section of pipe with the slip cap will go on the end opposite the supply / pump end. For systems longer than 12', connect sections of pipe together keeping holes aligned. **See Figure 14B.** Rotate pipe so that holes are straight upward (12 o'clock). **See Figure 14C.**

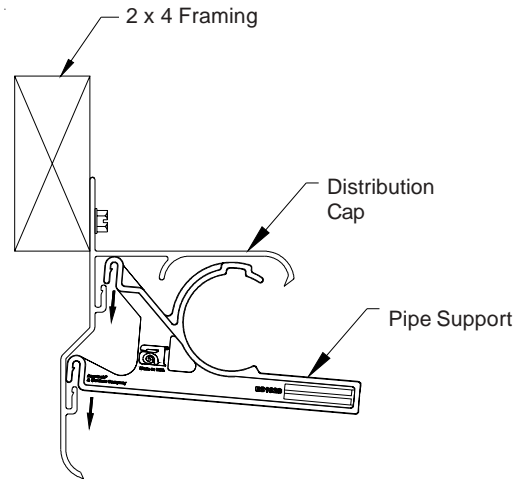

Figure 14A

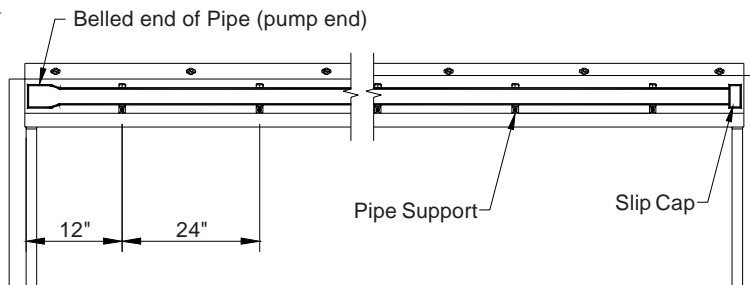

Figure 14B

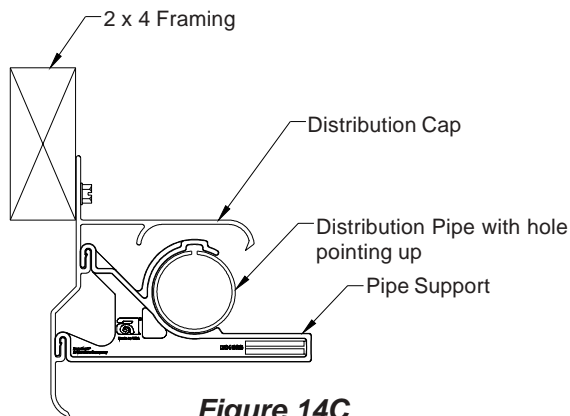

Figure 14C

21) Make sure caulk is dry and begin putting cooling pad in place, taking care to position pieces tight together. If your pad has Directional Arrows, position arrows to point upward and to the inside of the building. **See Figure 15.** Continue this pattern, stopping at the next to the last piece of pad.

21) Slide the next to the last piece of pad into the end panel. Measure the opening that is left for the last piece of pad at the top and bottom of the opening. If the opening is smaller than the width of the last piece of pad, then using a hand saw, trim the last piece of cooling pad to fit the opening. Put the last piece in place. **See Figure 16.**

22) Slide 10"L. pipe nipple through hole in end panel nearest the pump and fit it into the belled end of the distribution pipe. Make sure that the holes in the distribution pipe are pointing straight up.

23) Slide pad retainer onto pipe supports and fasten in place with bolt and thumb knob. **See Figure 17.** Slide pipe supports for alignment with pad retainer. Over tightening the pad retainer bolts will cause the pad retainer to tilt inward.

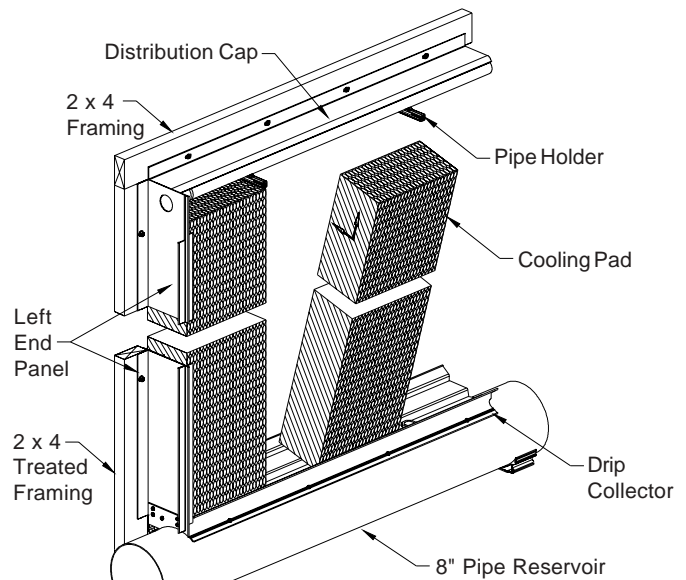

Figure 15

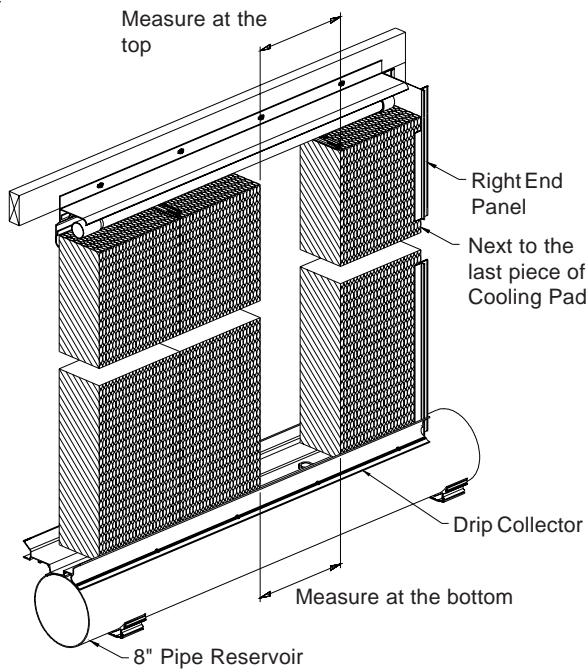

Figure 16

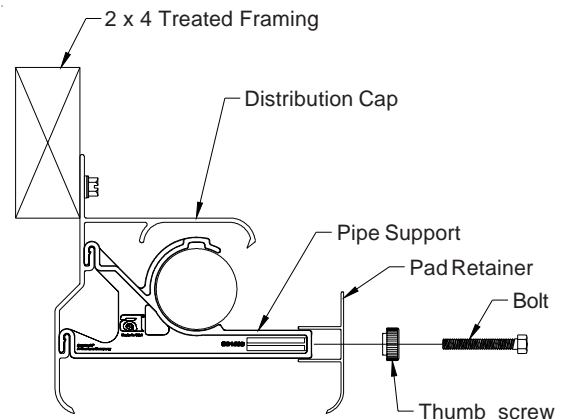
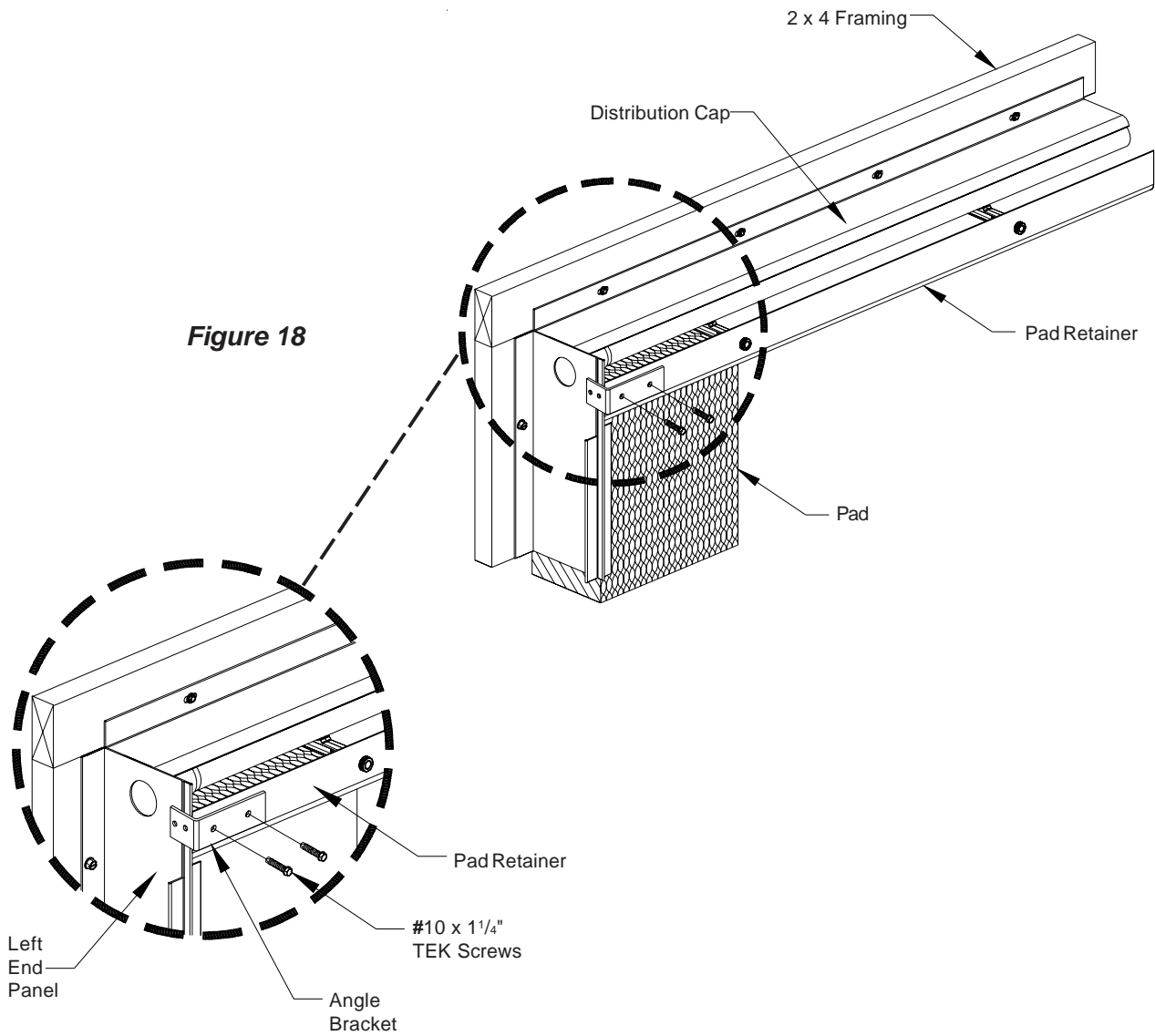

Figure 17

24) Holding the left end panel tight to distribution cap, place the long side of the Angle Bracket on the pad retainer and the short side over end panel. **See Figure 18.** Attach the angle bracket to the pad retainer using (2) #10 x 1/4" TEK screws (provided). Repeat for Right End Panel.



25) Installation of cooling frame is now complete. Installation should resemble that of **Figure 19A and 19B**. Proceed to next section for plumbing instructions.

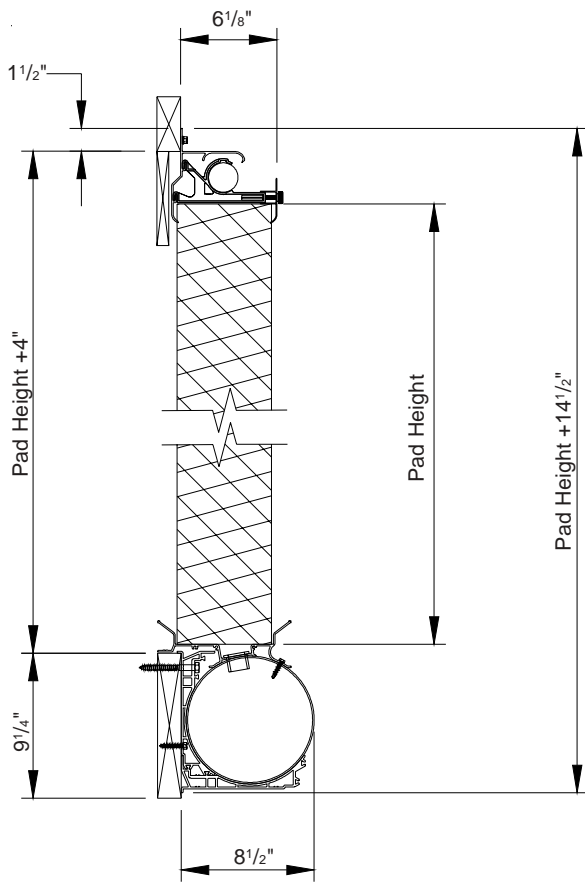

Figure 19A
SIDE VIEW
COMPLETED ASSEMBLY

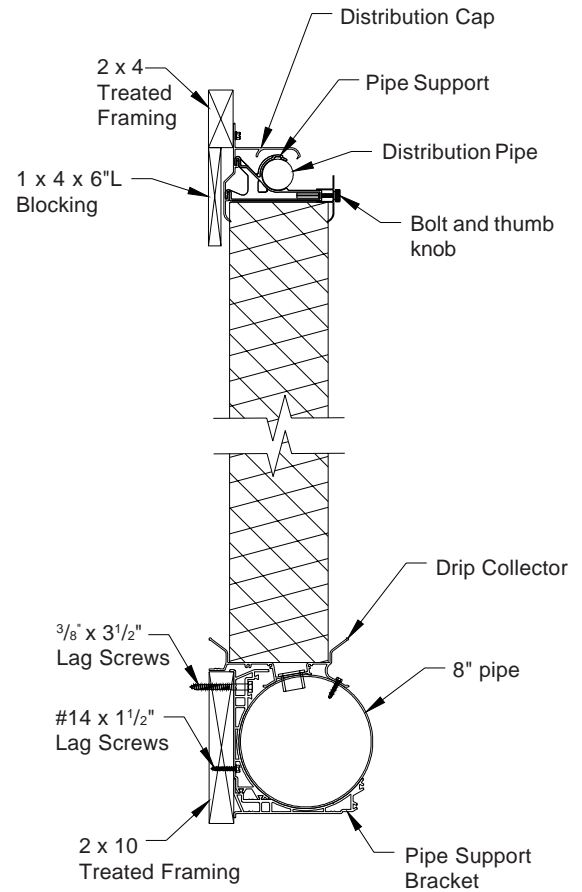

Figure 19B
SIDE VIEW
COMPLETED ASSEMBLY

PLUMBING

For White Pipe Tank proceed to Step 6.

Black Poly Tank:

- 1) Cut overflow spout at an angle as shown in **Figure 20A and 20B**.
- 2) Using mounting plate as a template, drill two (2) $\frac{9}{32}$ " diameter holes and attach mounting plate to tank using $\frac{1}{4}$ " x $\frac{3}{4}$ " wafer head bolts and flange nuts (provided). **See Figure 20B and 20C**.
- 3) Drill a $\frac{11}{16}$ " hole for float valve through the hole in the mounting plate. **See Figure 20C**.

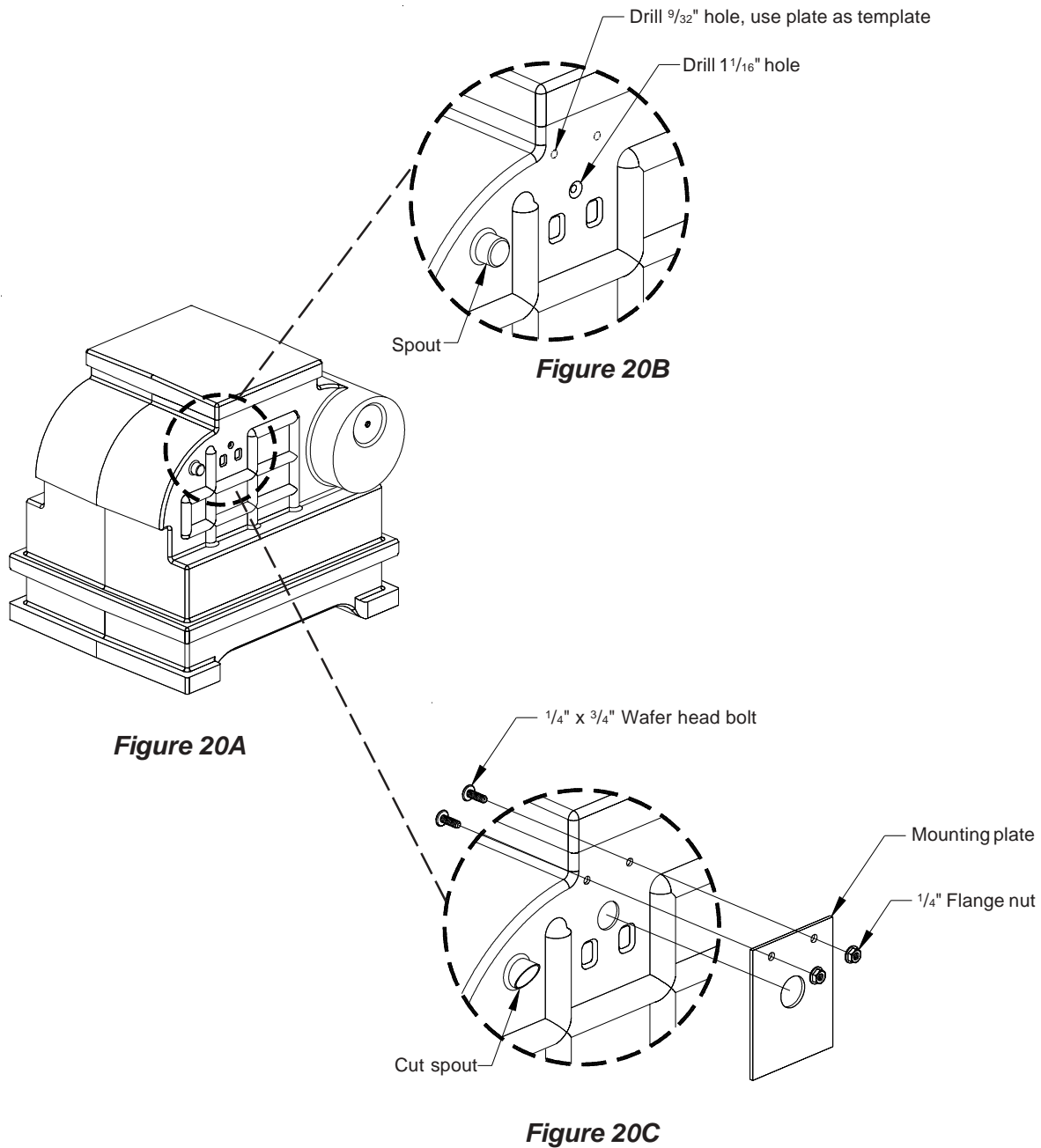

- 4) Remove wing nut and bolt from float assembly and use it to attach the float assembly to the valve assembly. **See Figure 20D.**
- 5) Attach the float valve assembly to the tank using washer, nut and garden hose adapter. **See Figure 20E.** The ball of the float valve may need some adjustment to attain proper water level in tank. Proper water level should be approximately 2" below the top of the 8" pipe or level with the opening in the overflow spout.

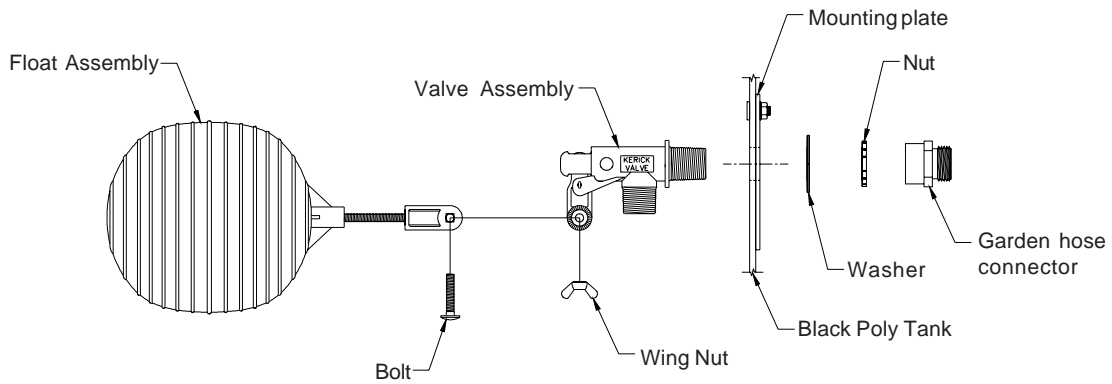

Figure 20D

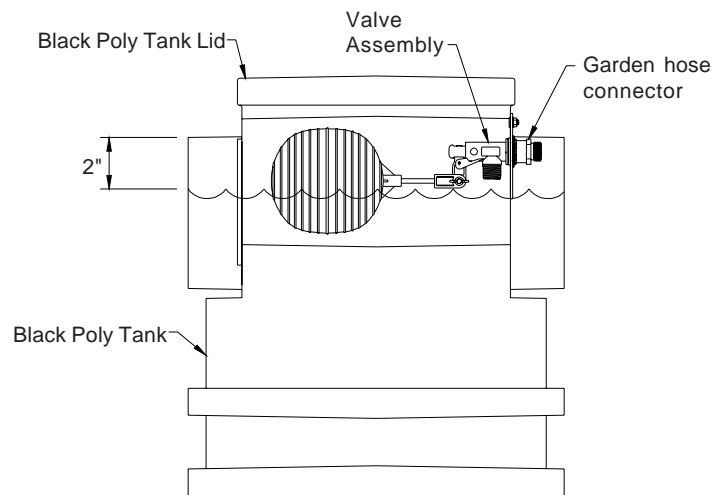

Figure 20E

- 6) Drill (4) $\frac{3}{16}$ " holes to install snap fasteners using the supplied pop rivets at locations shown in **Figure 20F**. Place the lid on the tank before drilling holes. Use the snap fastener for hole patterns.

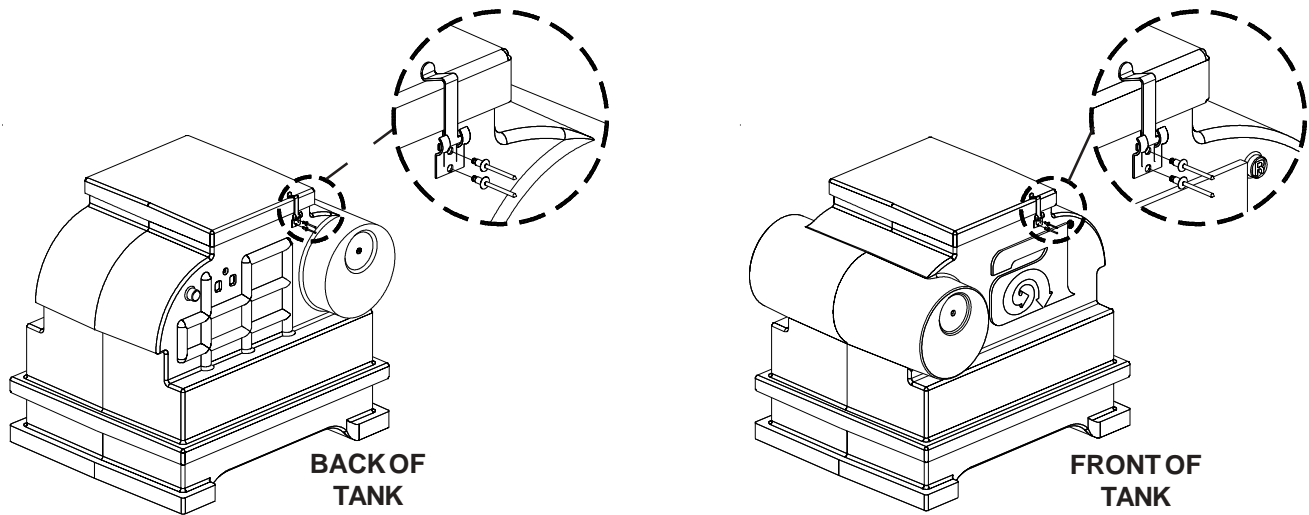
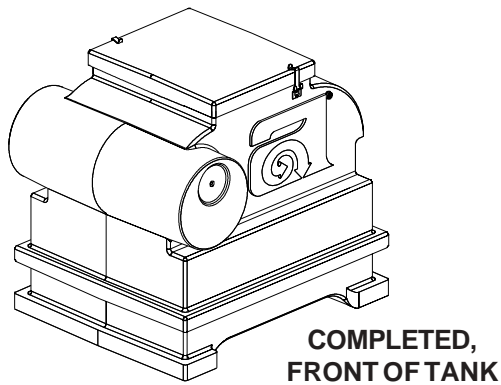

Figure 20F



- 5) Cut tank lid to fit around the $1\frac{1}{2}$ " water supply line connected to the pump. Make the cut to match the location of the pump. **See Figure 20G.**

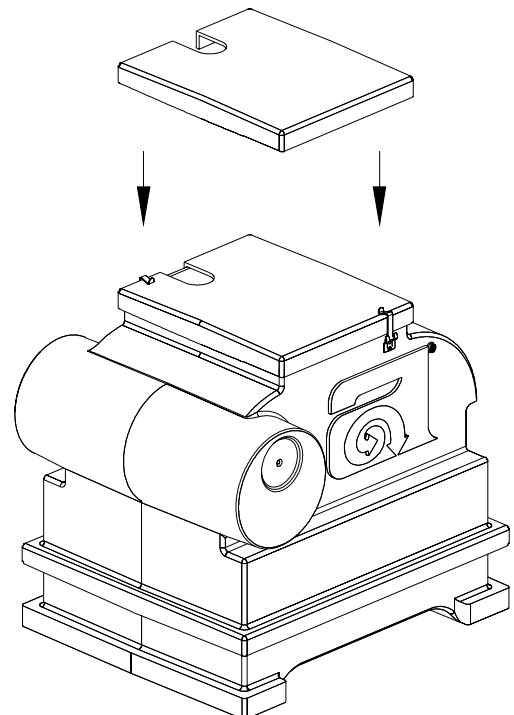

Figure 20G

White Pipe Tank

- 6) PVC glue the drain fitting and slide into hole in tee from inside-out. Prime and PVC cement drain fitting and 90° Elbow (overflow) and slide elbow over drain fitting, elbow should turn down. **See Figure 21.**
- 7) Remove wing nut and bolt from float assembly and use it to attach the float assembly to the valve assembly. **See Figure 22A.**
- 8) Prepare the float valve assembly, pipe, coupler and hose adapter in accordance to PVC primer and cement directions and assemble the float valve assembly, pipe, coupler and hose adapter. **See Figure 22B.**

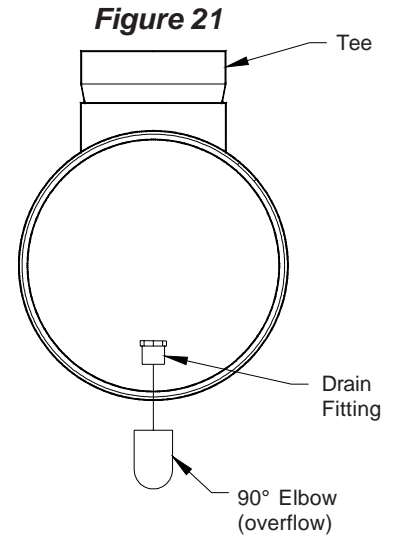
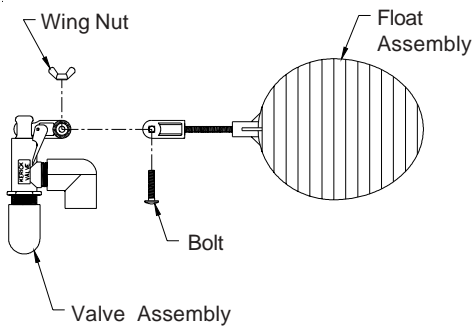
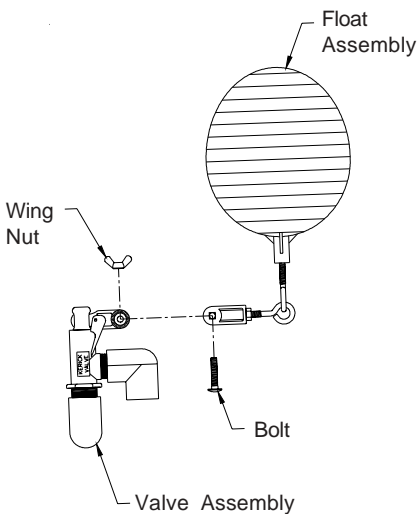

Figure 22A



15" TANK



10" TANK

Figure 22B

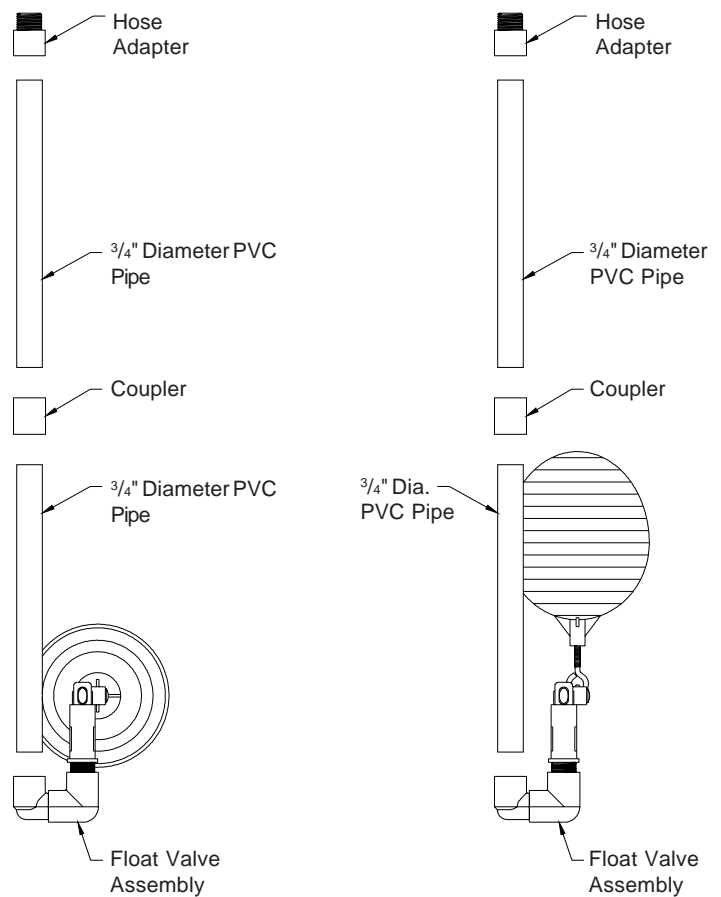

15" TANK

10" TANK

- 9) On the cooling system tank kit drill (4) $1\frac{1}{32}$ " dia. holes as shown in **Figure 22C**. The holes should be located on the side of the tank kit that is away from the building, and so that the float assembly can swing freely and is not obstructed by anything.

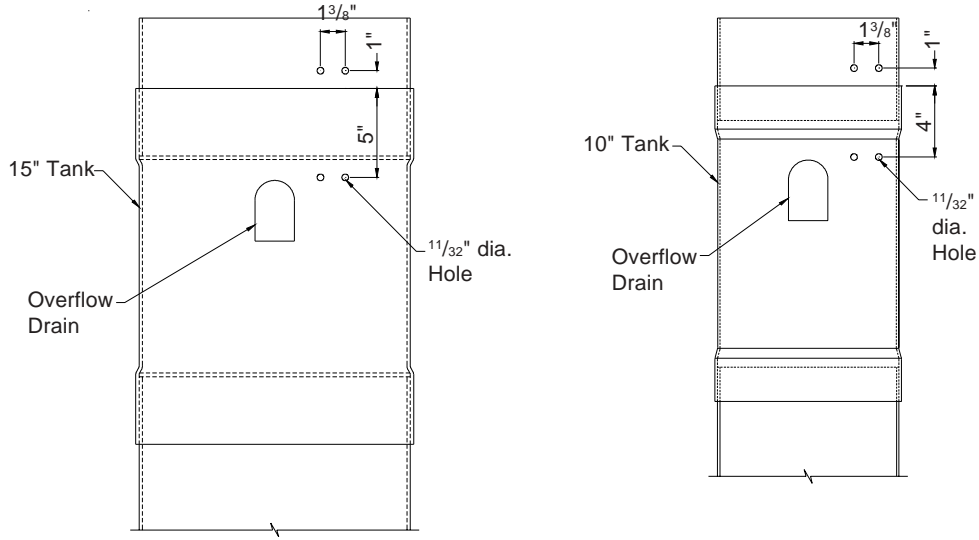

Figure 22C

15" TANK

10" TANK

- 10) Slide the float valve assembly into the tank kit tee approximately $18\frac{3}{4}$ " for the 15" tank and $25\frac{1}{4}$ " for the 10" tank. Fasten in place using (2) U-bolts and (4) nylon wing nuts. **See Figures 22D & 22E.**

Position of float valve is approximate, some adjustment may be required to attain proper water level in tank. Proper water level should be approximately 2" below the top of the 8" pipe.

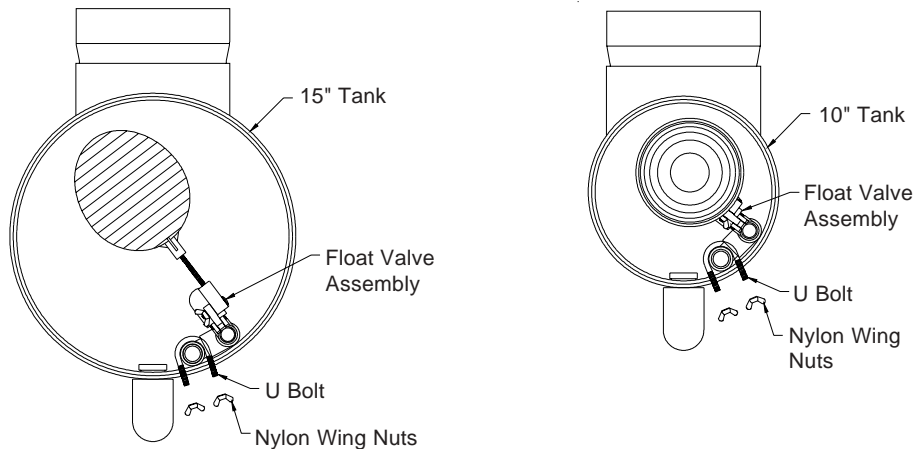
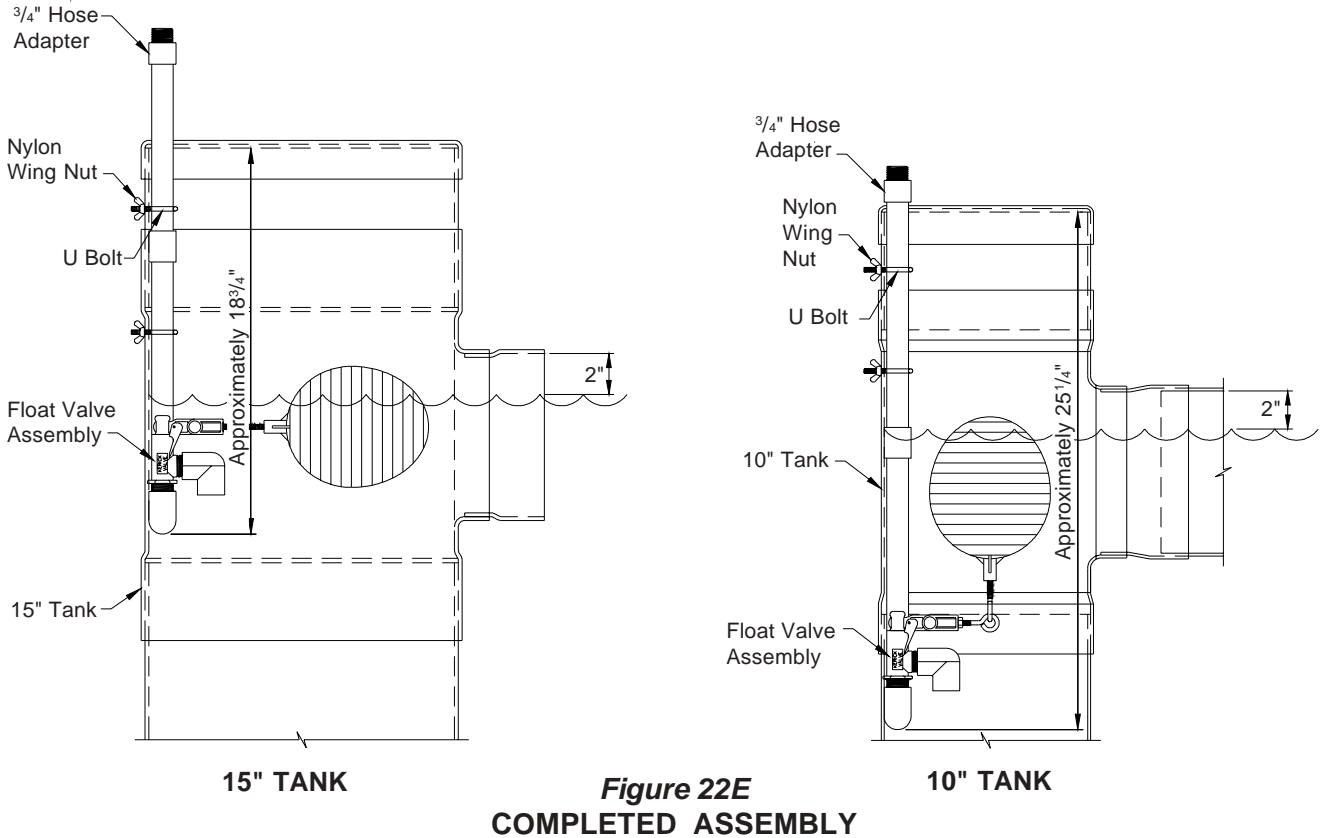

Figure 22D

15" TANK

10" TANK

- 11) Installation complete. If a higher water level is needed, loosen wing nuts and raise float assembly and retighten wing nuts. If lower level is needed, lower assembly. **See Figure 22E** for completed assembly.



FLUSH OUT KIT (EC1507) purchased separately

- 1) If Flush Out Kit (EC1507) was purchased, refer to page 14, Step 14a for instructions on drilling hole in end panel. Remove the TEK screw and pipe cap from the end of distribution pipe. Assemble Flush Out Kit piping as shown in **Figure 23**. Installation of the 90° elbow and (1) 1 1/2" x 10" pipe is optional, depending on the desired direction for water flow.
- 2) Replace pad retainer and tighten bolts. Flush Out Kit Assembly is now complete.

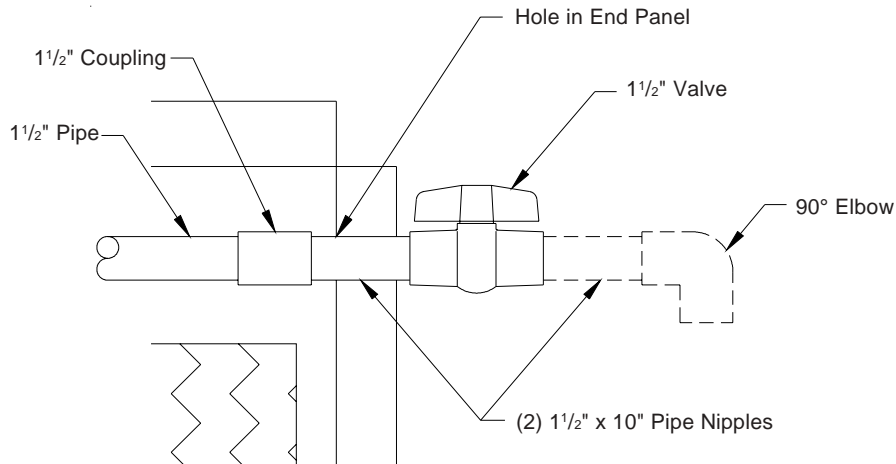

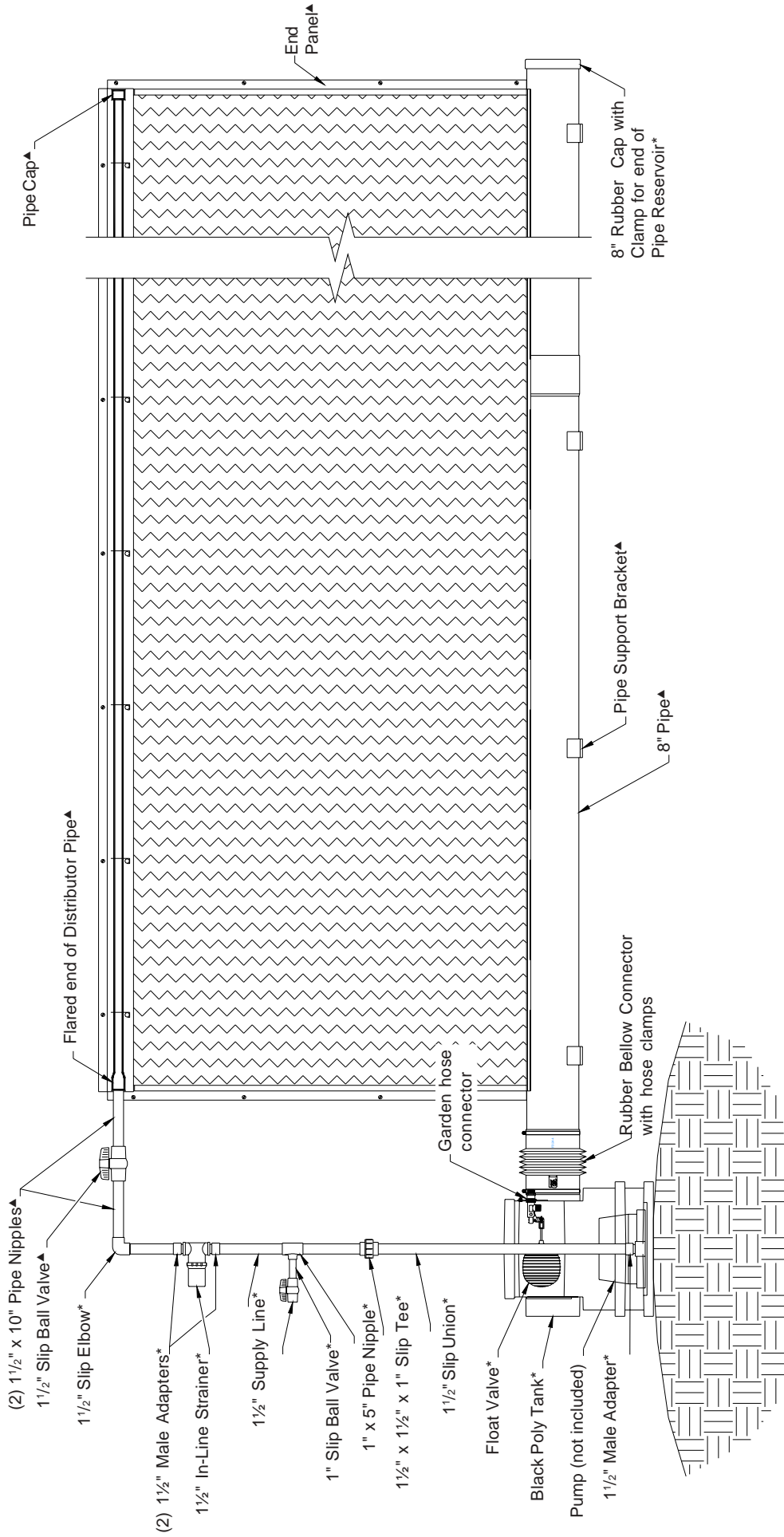

Figure 24
BLACK POLY TANK
ELEVATION VIEW WITH SUBMERSIBLE PUMP

▲Included with 'CP' cooling

*Included in EC1606 Tank Kit

Aerotech, A Munters Company
 4215 Legion Dr. Mason, MI 48854-1036 USA
 (517) 676-7070 Fax (517) 676-7078

FORM: QM1137
 Rev. 2, July 2006
 Page 29 of 37

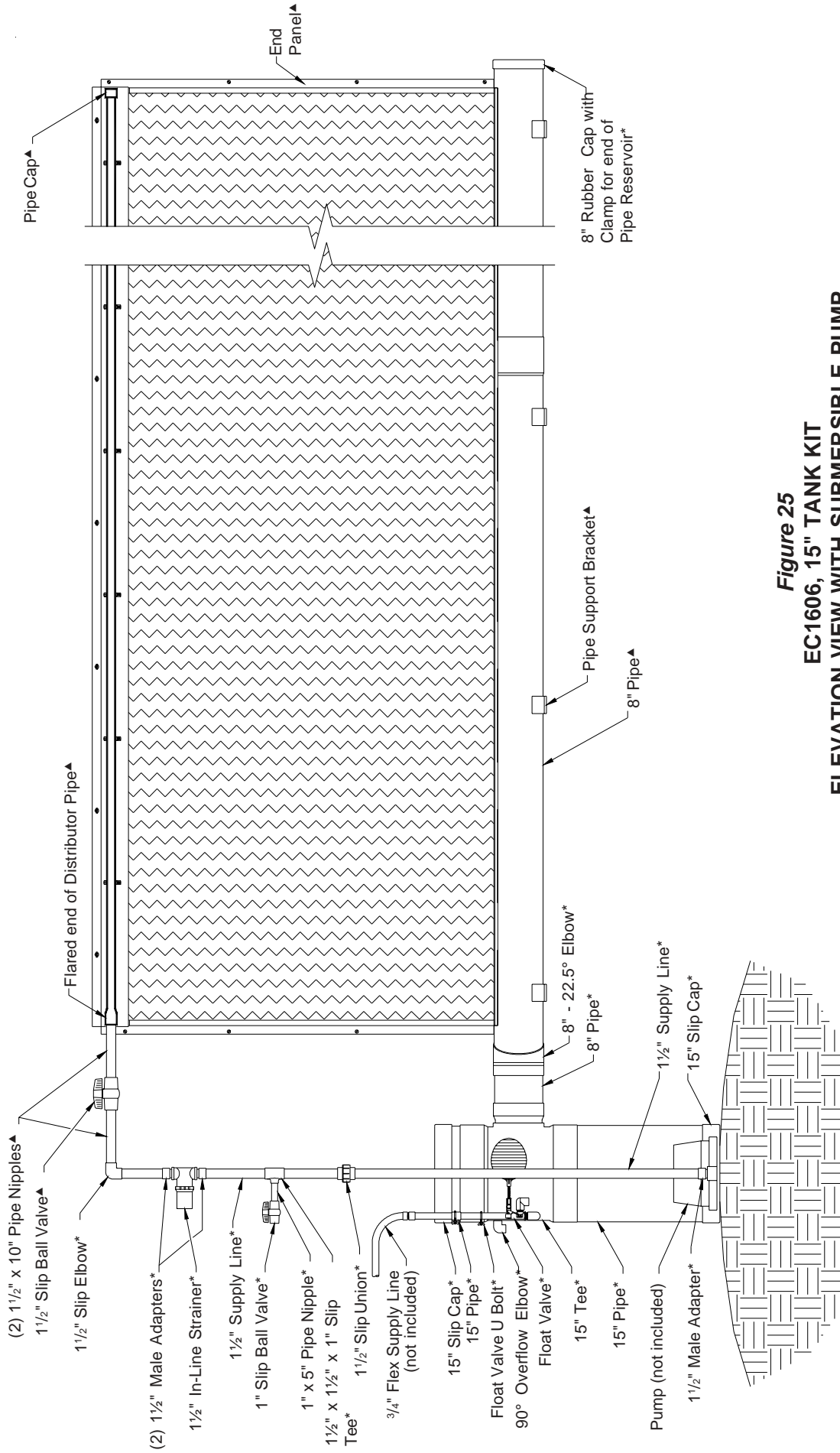

Figure 25
EC1606, 15" TANK KIT
ELEVATION VIEW WITH SUBMERSIBLE PUMP

▲Included with 'CP' cooling
 *Included in EC1606 Tank Kit

Aerotech, A Munters Company
 4215 Legion Dr. Mason, MI 48854-1036 USA
 (517) 676-7070 Fax (517) 676-7078

FORM: QM1137
 Rev. 2, July 2006
 Page 30 of 37

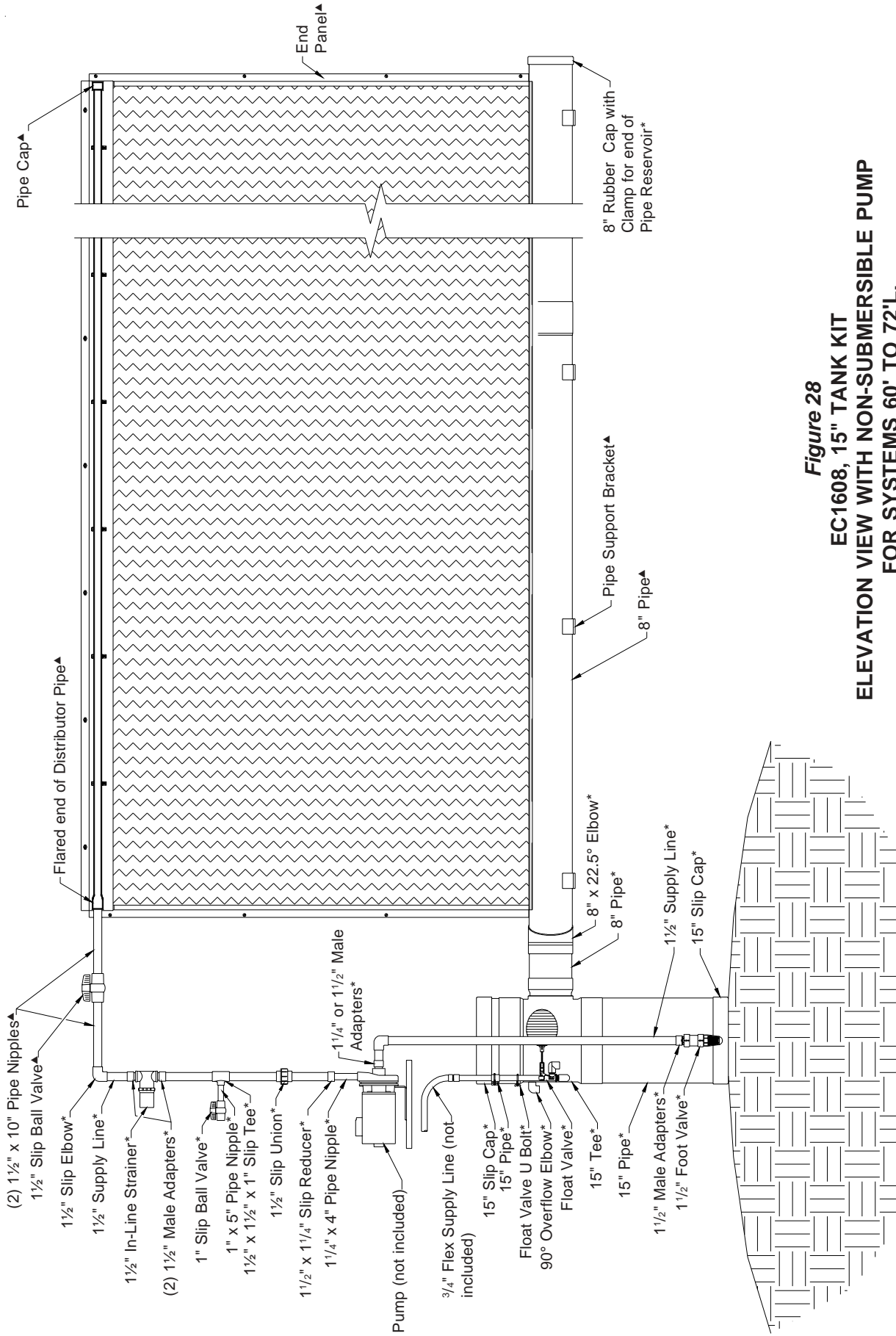

Figure 28
EC1608, 15" TANK KIT
ELEVATION VIEW WITH NON-SUBMERSIBLE PUMP
FOR SYSTEMS 60' TO 72'L.

▲ Included with 'CP' cooling
 * Included EC1608 Tank Kit

Aerotech, A Munters Company
 4215 Legion Dr. Mason, MI 48854-1036 USA
 (517) 676-7070 Fax (517) 676-7078

FORM: QM1137
 Rev. 2, July 2006
 Page 33 of 37

SYSTEM START-UP

- 1) Prime pump with water.
- 2) Turn on the electrical power and fresh water supplies.
- 3) Activate the pump by setting the cooling thermostat below room temperature.
- 4) Open the flow control valve at each cooling panel enough to completely saturate the pad material.
- 5) Adjust the bleed-off valve to discharge water from the cooling system at a rate of 1 gallon per hour per lineal foot of cooling system. For example: The bleed-off rate for a CP40 system (40'L.) would be 40 gallons per hour.

SYSTEM OPERATION AND ADJUSTMENT

- 1) Set the cooling setpoint on the temperature controller as shown on your Aerotech, A Munters Company ventilation system drawing. If this is not available contact your Aerotech field representative for proper settings.
- 2) Adjust the flow control valve at each cooling panel to give the pad material a "shiny wet" surface. Pad material performs best when as much water as possible is used, but the flow should not be so great that water falls from the material.
- 3) If the pad material remains dry on one side (with fans running), even at full water flow, adjust the distribution pipe so that the distribution holes are pointing straight upward.
- 4) If water drips from the cooling panel's upper edge, the pad material may be loose in its frame. Correct this by tightening the wing nuts on the front cover to press it more firmly against the pad material.
- 5) Water bleed-off is necessary to limit mineral deposits and other contaminants on the pad material by assuring the continuous addition of fresh water. The rate of, **1 gallon per hour per lineal foot** of cooling system, should be considered only as a starting point in determining the required amount of bleed-off. Due to differences in water hardness, a trial and error process must be used to determine the correct rate for your location.

After the cooling system has operated for a week or two, the sump water may become discolored or a light mineral coating may develop on the face of the pad material. If this occurs, increase the bleed-off rate slightly and observe the tendency of the coating to increase or stabilize. If after an extended period of time the mineral deposits become more visible, again increase the bleed-off rate.

Through this trial and error process a bleed-off rate will eventually be established at which the formation of new deposits will cease. Slightly increase the rate from this point to compensate for fluctuations in water hardness. The cooling system should now equalize and no more deposits should form.

MAINTENANCE

To maintain your cooling system in top condition, the recommendations given in **Chart D** should be treated as minimums. More frequent maintenance may be required at initial system start-up, in certain climates, and in areas with hard water conditions.

Chart D
MINIMUM MAINTENANCE SCHEDULE

| Maintenance Operation | SCHEDULE: | | |
|--|-----------|---------|--------|
| | Weekly | Monthly | Yearly |
| Clean the foot valve or the pump filter screen | | X | |
| Flush in-line strainer | X | | |
| Clean return water filter screen | X | | |
| Check for dry streaks on pad material | X | | |
| Clean debris from face of pad material | X | | |
| Clean cooling control and sensor | | X | |
| Clean cooling panel distribution pipe holes | | X | |
| Clean cooling panel collection trough | | | X |
| Drain and clean sump tank | | X | |
| Clean/check float valve | | X | |

MAINTENANCE CHECK-

LIST

⚠ WARNING



Do not allow fire, sparks, welding or smoking near dry pads.

⚠ WARNING



Do not apply unapproved chemical or commercial water treatments to sump or sump water.

Follow the guide lines below to prevent early pad failure and to get the maximum life from your pads.

1. Reduce the number of on-off cycles. **Do Not** use 10 minute cycle timers on pumps.
2. Shade the pads and sump to minimize algae growth.
3. Dry the pads out completely each night to kill algae. A 24 hour timer may be installed to shut pumps off at 10 pm and not allow them to come on until after 9 am.
4. Bleed off some water continuously to prevent concentration of minerals and dissolved chemicals in sump. Start with 1 gallon per hour for each linear foot of cooling system and adjust as necessary.
5. Drain and disinfect the water distribution system every three months to minimize algae, fungus and mineral build-up.
6. Run the recommended quantity of water over the pads. The pump must provide 3/4 gallon/minute for each linear foot of cooling system for 6" thick pad. For 4" pad, provide 1/2 gallon/minute for each linear foot of cooling system.
7. Periodically check for leaks in water distribution system.
8. Avoid harmful contaminants such as dust, fumes, fertilizers, harsh cleaners and water treatment chemicals.
9. Complete the items on the Maintenance Schedule as required.

WARNING: DO NOT add unapproved chemicals or commercial water treatments to the sump or supply water. If the above recommendations are followed and problems on the pad are observed such as algae growth, mineral deposits or softening of the pad material, contact Aerotech, A Munters Company for further recommendations.

WARRANTY: See Aerotech, A Munters Company Limited Warranty Statement

NOTE: Measure system, length and height before contacting your local representative or Aerotech office.

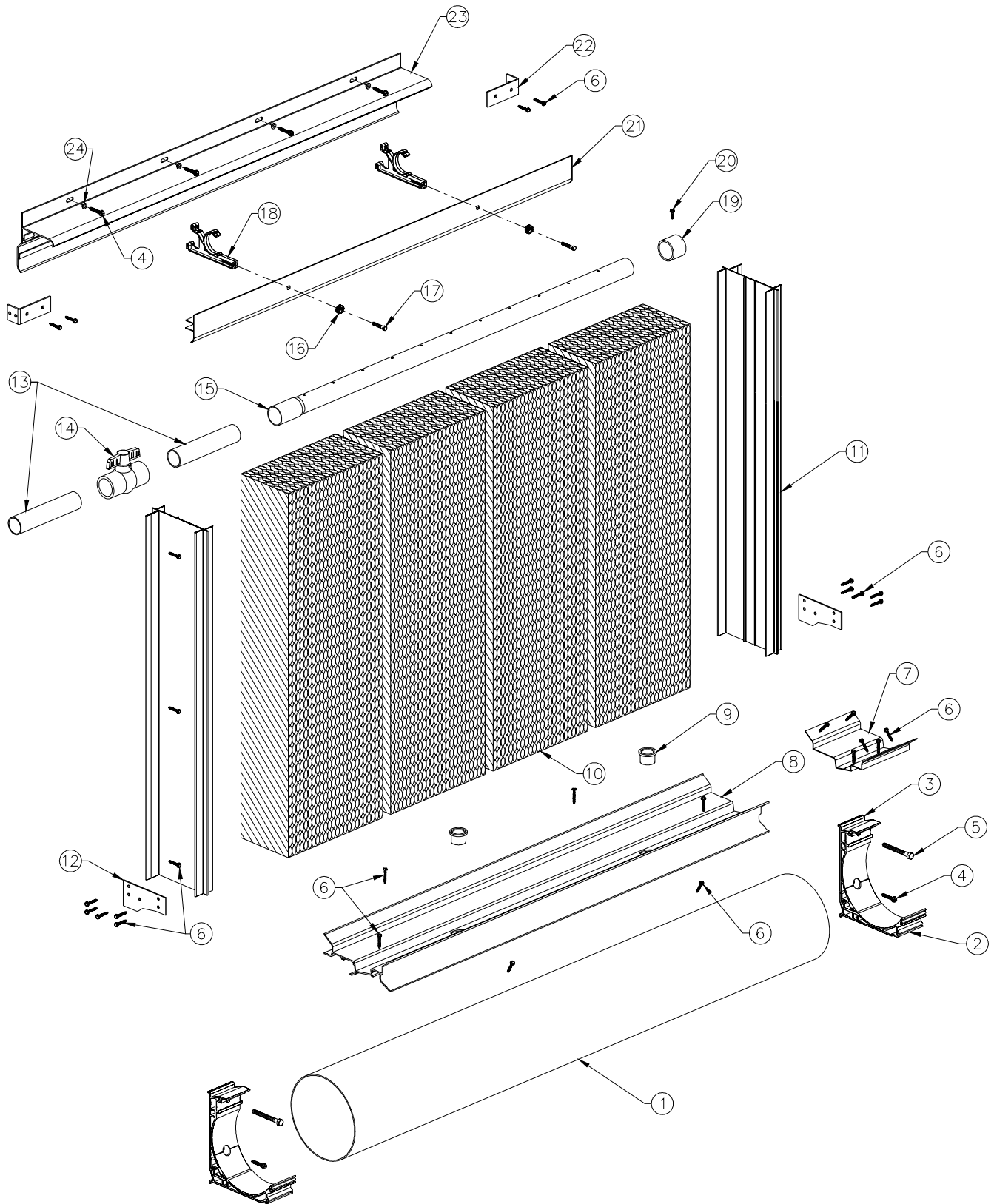

*Catalog No. changes depending on type and size of pad.



| Ref. No. | Cat. No. | Description | Qty. |
|----------|----------|--|-------------|
| 1 | JP3018 | 8" Dia. Air Pipe (PIP 50) white PVC | varies/foot |
| 2 | EC1328 | Pipe Support Bracket, without holes, aluminum | varies/foot |
| 3 | EC1330 | Pipe Support Bracket, with holes, aluminum | varies/foot |
| 4 | KS2105 | Lag Screw, #14 x 1 1/2", stainless steel | varies |
| 5 | KS2462 | Lag Screw, 3/8" x 3 1/2", Zinc Plated | varies |
| 6 | KS2257 | TEK Screw, #10 x 1 1/4" Hex Washer, stainless steel | varies |
| 7 | EC1340 | Drip Collector Splice, 6"W., white plastic | varies |
| 8 | EC1290 | Drip Collector, 2'L., white plastic | varies |
| | EC1291 | Drip Collector, 4'L., white plastic | varies |
| | EC1296 | Drip Collector, 5'L., white plastic | varies |
| | EC1294 | Drip Collector, 10'L., white plastic | varies |
| 9 | EC1148 | Drain Fitting, 1" x 3/4", Schedule 40, gray plastic | varies |
| 10 | EC1103* | Pad Material (see Price Sheet PCSA or PCSP) | varies |
| 11 | EC1046 | End Panel, 75.25"H., white plastic | 2 |
| 12 | EC1310 | Drip Collector End Cap, white plastic | 2 |
| 13 | EC1299 | Pipe Nipple 1 1/2" x 10"L. Schedule SDR21, white PVC | 2 |
| 14 | EC1224 | Ball Valve, 1 1/2" Slip, Schedule 40, white PVC | 1 |
| 15 | EC1298 | Distribution Pipe, 1 1/2" Dia. with 1/8" Dia. holes, 3" O.C. | varies |
| 16 | KX1140 | Thumb Knob, black plastic | varies |
| 17 | KS1006 | Bolt, 1 3/4" x 1/4" Dia., stainless steel | varies |
| 18 | EC1028 | Pipe Support, black plastic | varies |
| 19 | EC1226 | Slip Cap, 1 1/2" Schedule 40 white PVC | 1 |
| 20 | KS2252 | TEK Screw, #10 x 3/4", stainless steel | 1 |
| 21 | EC1571 | Pad Retainer, Open Style, 2' L., white plastic | varies/foot |
| | EC1565 | Pad Retainer, Open Style, 4' L., white plastic | varies/foot |
| | EC1570 | Pad Retainer, Open Style, 5' L., white plastic | varies/foot |
| | EC1568 | Pad Retainer, Open Style, 10' L., white plastic | varies/foot |
| 22 | EC1202 | Angle Bracket, 1 1/2" x 4" x 1 1/2", aluminum | 2 |
| 23 | EC1578 | Distribution Cap, 2' L., white plastic | varies/foot |
| | EC1572 | Distribution Cap, 4' L., white plastic | varies/foot |
| | EC1579 | Distribution Cap, 5' L., white plastic | varies/foot |
| | EC1576 | Distribution Cap, 10' L., white plastic | varies/foot |
| 24 | KX1120 | Bushing 5/16" I.D. x 1/2" O.D. 3/16"L, white plastic | varies |