

Air extraction fan  
Estrattore d'aria  
Ventilateur Extraction  
Abzugshauben  
Ventiladores extractores  
Ventiladores extractores

Saturn ONE

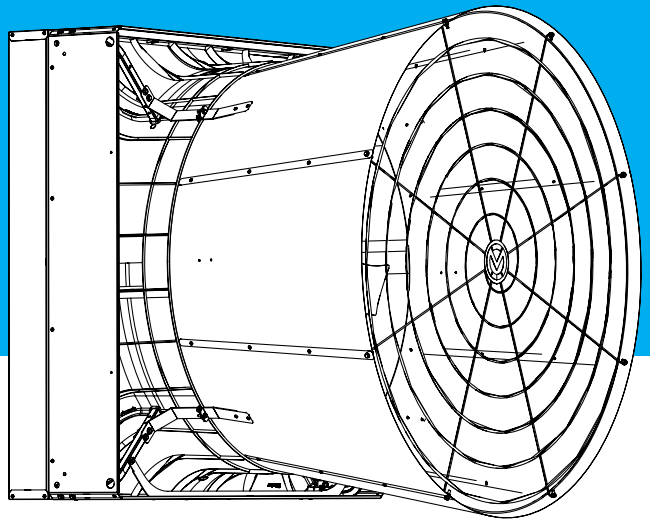

AM\_SaturnONE\_V2\_202403\_Multi  
P/N 2200223

- GB** *Assembly instructions*
- I** *Istruzioni di assemblaggio*
- F** *Instructions d'assemblage*
- D** *Montageanleitung*
- E** *Instrucciones de ensamblaje*
- P** *Instruções de montagem*



**Saturn ONE High Efficiency**
**MODEL: BELT DRIVE TRASMISSION**

Modello:	Trasmissione a cinghia
Modèle:	Commande par courroie
Modell:	Riemenantrieb
Modelo:	Transmisión por correa
Modelo:	Acionamento por correias

**MOTOR POWER: 1,5 HP**

Potenza Motore	1,5 Hp
Puissance moteur	1,5 Hp
Motorleistung	1,5 Hp
Potencia del motor	1,5 Hp
Potência do motor	1,5 Hp

**PROPELLER: 3 BLADES**

Elica	3 Pale
Hélice	3 Pales
Propeller	3 Schaufeln
Hélice	3 álabes
Hélice	3 Pás

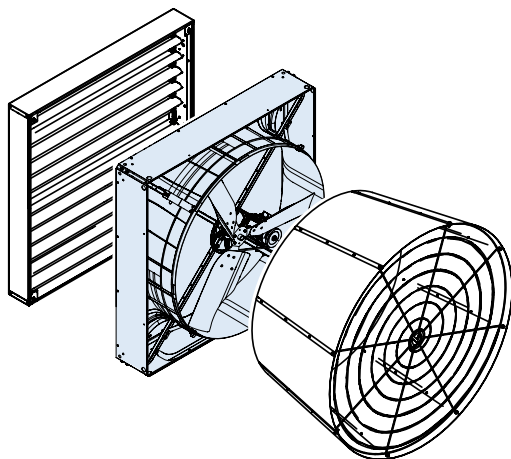

**Saturn ONE High Pressure**
**MODEL: BELT DRIVE TRASMISSION**

Modello:	Trasmissione a cinghia
Modèle:	Commande par courroie
Modell:	Riemenantrieb
Modelo:	Transmisión por correa
Modelo:	Acionamento por correias

**MOTOR POWER: 2 HP**

Potenza Motore	2 Hp
Puissance moteur	2 Hp
Motorleistung	2 Hp
Potencia del motor	2 Hp
Potência do motor	2 Hp

**PROPELLER: 6 BLADES**

Elica	6 Pale
Hélice	6 Pales
Propeller	6 Schaufeln
Hélice	6 álabes
Hélice	6 Pás

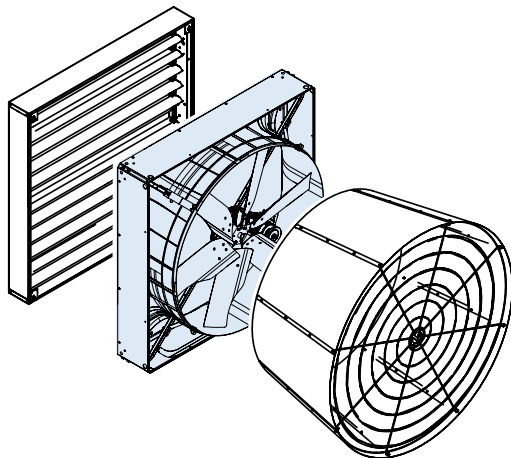



## Saturn ONE Direct Drive

### MODEL:

Modello:	Trasmissione diretta
Modèle:	Entraînement direct
Modell:	Direktantriebs
Modelo:	Transmisión directa
Modelo:	Transmissão direta

### MOTOR POWER: 2 HP

Potenza Motore	2 Hp
Puissance moteur	2 Hp
Motorleistung	2 Hp
Potencia del motor	2 Hp
Potência do motor	2 Hp

### PROPELLER: 3-5 BLADES

Elica	3-5 Pale
Hélice	3-5 Pales
Propeller	3-5 Schaufeln
Hélice	3-5 álabes
Hélice	3-5 Pás

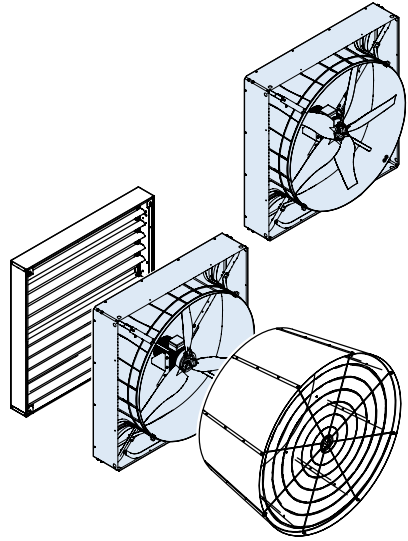

## Saturn ONE Electronically Commutated

### MODEL:

Modello:	Trasmissione diretta
Modèle:	Entraînement direct
Modell:	Direktantriebs
Modelo:	Transmisión directa
Modelo:	Transmissão direta

### MOTOR POWER: 3 HP

Potenza Motore	3 Hp
Puissance moteur	3 Hp
Motorleistung	3 Hp
Potencia del motor	3 Hp
Potência do motor	3 Hp

### PROPELLER: 3-5 BLADES

Elica	3-5 Pale
Hélice	3-5 Pales
Propeller	3-5 Schaufeln
Hélice	3-5 álabes
Hélice	3-5 Pás

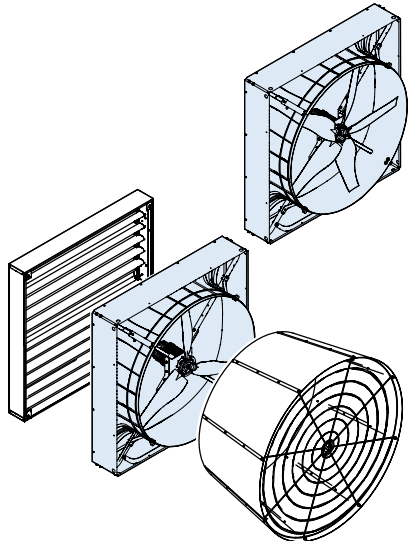



















# Summary / Sommario / Sommaire / Inhaltsangabe / Resumen / Sumário

BODY AND MOTOR ASSEMBLY .....	10	Op.12 ASSEMBLY OF MOTOR SUPPORTS / ASSEMBLAGGIO SUPPORTI MOTORE / ASSEMBLAGE SUPPORTS MOTEUR / MONTAGE VON MOTORTRÄGERN/ENSAMBLAJE DE LOS SOPORTES PARA EL MOTOR / MONTAGEM DOS SUPORTES DO MOTOR .....	17
ASSEMBLAGGIO CARROZZERIA E MOTORE .....	10	Op.13 MOTOR MOUNTING / MONTAGGIO MOTORE / MONTAGE DU MOTEUR / MONTAGE DES MOTORS / MONTAJE DEL MOTOR / MONTAGEM DO MOTOR .....	18
ASSEMBLAGE CARROSSERIE ET MOTEUR .....	10	Op.13 MOTOR MOUNTING / MONTAGGIO MOTORE / MONTAGE DU MOTEUR / MONTAGE DES MOTORS / MONTAJE DEL MOTOR / MONTAGEM DO MOTOR .....	18
ZUSAMMENBAU VON AUFBAU UND MOTOR .....	10	Op.13 MOTOR MOUNTING / MONTAGGIO MOTORE / MONTAGE DU MOTEUR / MONTAGE DES MOTORS / MONTAJE DEL MOTOR / MONTAGEM DO MOTOR .....	19
ENSAMBLAJE DE LA CARROCERÍA Y DEL MOTOR .....	10	Op.14 CONDENSATE DRAIN AND FAIRLEAD/SCARICO CONDENSA E PASSACAVO/ÉCOULEMENT DES CONDENSATS ET PRESSE-ÉTOUPE/KONDENSATABLAUF UND KABELVERSCHRAUBUNG/ESCAPE CONDENSACIÓN Y PASACABLES/DESCARGA DE CONDENSACIÓN E ILHÓ .....	19
MONTAGEM DO CORPO E DO MOTOR .....	10	Op.15 TRANSMISSION BELT MOUNTING / MONTAGGIO CINGHIA TRASMISSIONE / MONTAGE DE LA COURROIE DE TRANSMISSION / MONTAGE DES ANTRIEBSRIEMENS / MONTAJE DE LA CORREA DE TRANSMISSION / MONTAGEM DA CORREIA DE TRANSMISSÃO .....	20
Op.01 SUPERSTRUCTURE ASSEMBLY / ASSEMBLAGGIO SUPERSTRUTTURA / MONTAGE STRUCTURE SUPÉRIEURE / ZUSAMMENBAU DER SUPERSTRUKTUR/ENSAMBLAJE DE LA SUPERESTRUCTURA / MONTAGEM DA SUPERESTRUTURA .....	10	Op.16 FAN MOUNTING / MONTAGGIO VENTOLA / MONTAGE DU VENTILATEUR / MONTAGE DES LÜFTERS / MONTAJE DEL VENTILADOR / MONTAGEM DA VENTONINHA .....	21
Op.01 SUPERSTRUCTURE ASSEMBLY / ASSEMBLAGGIO SUPERSTRUTTURA / MONTAGE STRUCTURE SUPÉRIEURE / ZUSAMMENBAU DER SUPERSTRUKTUR/ENSAMBLAJE DE LA SUPERESTRUCTURA / MONTAGEM DA SUPERESTRUTURA .....	11	Op.16 FAN MOUNTING / MONTAGGIO VENTOLA / MONTAGE DU VENTILATEUR / MONTAGE DES LÜFTERS / MONTAJE DEL VENTILADOR / MONTAGEM DA VENTONINHA .....	21
Op.01 SUPERSTRUCTURE ASSEMBLY / ASSEMBLAGGIO SUPERSTRUTTURA / MONTAGE STRUCTURE SUPÉRIEURE / ZUSAMMENBAU DER SUPERSTRUKTUR/ENSAMBLAJE DE LA SUPERESTRUCTURA / MONTAGEM DA SUPERESTRUTURA .....	11	Op.16 FAN MOUNTING / MONTAGGIO VENTOLA / MONTAGE DU VENTILATEUR / MONTAGE DES LÜFTERS / MONTAJE DEL VENTILADOR / MONTAGEM DA VENTONINHA .....	22
Op.02 HUB ASSEMBLY / ASSEMBLAGGIO MOZZO / ASSEMBLAGE DU MOYEU / MONTAGE DER NABE / ENSAMBLAJE DEL PORTABUJE / MONTAGEM DO CUBO .....	12	Op.16 FAN MOUNTING / MONTAGGIO VENTOLA / MONTAGE DU VENTILATEUR / MONTAGE DES LÜFTERS / MONTAJE DEL VENTILADOR / MONTAGEM DA VENTONINHA .....	22
Op.03 HUB FIXING ON STRUCTURE / FISSAGGIO MOZZO SU STRUTTURA / FIXATION DU MOYEU SUR LA STRUCTURE / BEFESTIGUNG DER NABE AN DER STRUKTUR / FIJACIÓN DEL PORTABUJE SOBRE LA ESTRUCTURA / FIXAÇÃO DO CUBO À ESTRUTURA .....	12	AGS SHUTTER ASSEMBLY .....	23
Op.04 CONVEYOR ASSEMBLY / ASSEMBLAGGIO CONVOGLIATORE / ASSEMBLAGE DU CONVOYEUR / MONTAGE DER FÖRDERER-BAUGRUPPE / ENSAMBLAJE DEL TRANSPORTADOR / MONTAGEM DA TRANSPORTADORA .....	13	ASSEMBLAGGIO SERRANDA AGS .....	23
Op.05 CONVEYOR FIXING ON STRUCTURE/FISSAGGIO CONVOGLIATORE SU STRUTTURA/FIXATION DU CONVOYEUR SUR LA STRUCTURE/BEFESTIGUNG DES FÖRDERERS AN DER STRUKTUR/FIJACIÓN DEL TRANSPORTADOR SOBRE LA ESTRUCTURA/FIXAÇÃO DA TRANSPORTADORA .....	14	ASSEMBLAGE ENSEMBLE AMORTISSEUR AGS .....	23
Op.06 REINFORCEMENT BRACKET FIXING/FISSAGGIO STAFFA DI RINFORZO/FIXATION DE L'ÉQUERRE DE RENFORCEMENT/BEFESTIGUNG VON VERSTÄRKUNGSBÜGELN/FIJACIÓN DEL ESTRIBO DE REFUERZO / FIXAÇÃO DA HASTE DE REFORÇO .....	14	ZUSAMMENBAU DER AGS-KLAPPE .....	23
Op.07 PANEL ASSEMBLY / ASSEMBLAGGIO PANNELLI / ASSEMBLAGE DES PANNEAUX / PANEEL-MONTAGE / ENSAMBLAJE DE LOS PANELES / MONTAGEM DOS PAINÉIS .....	15	ENSAMBLAJE DE LA PERSIANA AGS .....	23
Op.08 PANEL ASSEMBLY / ASSEMBLAGGIO PANNELLI / ASSEMBLAGE DES PANNEAUX / PANEEL-MONTAGE / ENSAMBLAJE DE LOS PANELES / MONTAGEM DOS PAINÉIS .....	15	MONTAGEM DO REVESTIMENTO AGS .....	23
Op.09 PANEL ASSEMBLY / ASSEMBLAGGIO PANNELLI / ASSEMBLAGE DES PANNEAUX / PANEEL-MONTAGE / ENSAMBLAJE DE LOS PANELES / MONTAGEM DOS PAINÉIS .....	16	Op.17 AGS STRUCTURE ASSEMBLY / ASSEMBLAGGIO PANNELLI AGS / ASSEMBLAGE DE LA STRUCTURE AGS / ZUSAMMENBAU DER AGS-STRUKTUR / ENSAMBLAJE ESTRUCTURA AGS / MONTAGEM DA ESTRUTURA AGS .....	23
Op.10 ANGLE BRACKETS MOUNTING / MONTAGGIO STAFFE ANGOLARI / MONTAGE DES ÉQUERRES D'ANGLE / MONTAGE WINKELHALTERUNGEN / MONTAJE DE LOS ESTRIBOS ANGULARES / MONTAGEM DE SUPORTES ANGULARES .....	16	Op.18 PLATES ASSEMBLY / ASSEMBLAGGIO PIASTRE / ASSEMBLAGE DES PLAQUES / ZUSAMMENBAU DER PLATTEN / ENSAMBLAJE DE LAS PLACAS / MONTAGEM DE PLACAS (HIGH EFFICIENCY - DIRECT DRIVE - HIGH PRESSURE) .....	24
Op.11 PANEL ASSEMBLY / ASSEMBLAGGIO PANNELLI / ASSEMBLAGE DES PANNEAUX / PANEEL-MONTAGE / ENSAMBLAJE DE LOS PANELES / MONTAGEM DOS PAINÉIS/MONTAGGIO PROFILO DELL'OSCURANTE .....	17	Op.19 AGS GEAR UNIT ASSEMBLY (RIGHT) / MONTAGGIO GRUPPO INGRANAGGI AGS (DX) / MONTAGE GROUPE D'ENGRÉNAGES AGS (DROITE) / MONTAGE DER ZAHNRADBAUGRUPPE AGS (RECHTS) / MONTAJE GRUPO ENGRANAJES AGS (DCHO) / MONTAGEM DO GRUPO DE ENGRENAGENS AGS (DIR) .....	24
		Op.20 AGS GEAR UNIT ASSEMBLY (LEFT) / MONTAGGIO GRUPPO INGRANAGGI AGS (SX) / MONTAGE GROUPE D'ENGRÉNAGES AGS (GAUCHE) / MONTAGE DER ZAHNRADBAUGRUPPE AGS (LINKS) / MONTAJE GRUPO ENGRANAJES AGS (IZQ) / MONTAGEM DO GRUPO DE ENGRENAGENS (ESQ) .....	25

## Summary / Sommario / Sommaire / Inhaltsangabe / Resumen / Sumário

<p>Op.21 AGS SHUTTER PROFILE ASSEMBLY (RIGHT) / MONTAGGIO PROFILO DELL'OTTURATORE AGS (DX) / MONTAGE DE PROFILÉS D'OBTURATEUR AGS (DROITE) / MONTAGE DER VERSCHLUSS AGS (RECHTS) / MONTAJE DE LA CERRADURA AGS (DERECHA) / MONTAGEM DA FECHADURA AGS (DIR) ..... 25</p> <p>Op.22 AGS SHUTTER PROFILE ASSEMBLY (LEFT) / MONTAGGIO PROFILO DELL'OTTURATORE AGS (SX) / MONTAGE DE PROFILÉS D'OBTURATEUR AGS (GAUCHE) / MONTAGE DER VERSCHLUSS AGS (LINKS) / MONTAJE DE LA CERRADURA AGS (IZQ) / MONTAGEM DA FECHADURA AGS (ESQ) ..... 26</p> <p>Op.23 PALLET ASSEMBLY UPPER POSITION / ASSEMBLAGGIO PALETTA POSIZIONE SUP. / ASSEMBLAGE PLAQUE POSITION SUP. / ZUSAMMENBAU DER SCHAUFEL IN DER OBEREN POSITION / ENSAMBLAJE DE LA PALETA EN POSICIÓN SUP. / MONTAGEM DA PALETA DE POSIÇÃO SUP. .... 26</p> <p>Op.23 PALLET ASSEMBLY UPPER POSITION / ASSEMBLAGGIO PALETTA POSIZIONE SUP. / ASSEMBLAGE PLAQUE POSITION SUP. / ZUSAMMENBAU DER SCHAUFEL IN DER OBEREN POSITION / ENSAMBLAJE DE LA PALETA EN POSICIÓN SUP. / MONTAGEM DA PALETA DE POSIÇÃO SUP. .... 27</p> <p>Op.24 ACTUATOR PLATE ASSEMBLY / ASSEMBLAGGIO PALETTA ATTUATORE / ASSEMBLAGE PLAQUE DE L'ACTIONNEUR / ZUSAMMENBAU DER SCHAUFEL FÜR AKTUATOR / ENSAMBLAJE DE LA PALETA DE ACTUADOR / CONJUNTO DE PÁ DO ATUADOR ..... 27</p> <p>Op.25 PALLET ASSEMBLY LOWER POSITION / ASSEMBLAGGIO PALETTA POSIZIONE INF. / ASSEMBLAGE PLAQUE POSITION INF. / ZUSAMMENBAU DER SCHAUFEL IN DER UNTEREN POSITION / ENSAMBLAJE DE LA PALETA EN POSICIÓN INF. / MONTAGEM DA PALETA DE POSIÇÃO INF. .... 28</p> <p>Op.25 PALLET ASSEMBLY LOWER POSITION / ASSEMBLAGGIO PALETTA POSIZIONE INF. / ASSEMBLAGE PLAQUE POSITION INF. / ZUSAMMENBAU DER SCHAUFEL IN DER UNTEREN POSITION / ENSAMBLAJE DE LA PALETA EN POSICIÓN INF. / MONTAGEM DA PALETA DE POSIÇÃO INF. .... 28</p> <p>Op.26 ACTUATED BLADE ASSEMBLY / ASSEMBLAGGIO PALETTA PER MOLLA / ASSEMBLAGE PLAQUE POUR MOLETTE / ZUSAMMENBAU DER SCHAUFEL FÜR FEDER / ENSAMBLAJE DE LA PALETA CON RESORTE / MONTAGEM DA PALETA PARA MOLA ..... 29</p> <p>Op.27 PALLET ASSEMBLY UPPER POSITION / MONTAGGIO PALETTE POSIZ SUPERIORE / MONTAGE PLAQUES POS. SUPÉRIEURE / MONTAGE DER SCHAUFEL IN DER OBEREN POSITION / MONTAJE DE LAS PALETAS EN POSICIÓN SUP. / MONTAGEM DA PALETA POSIÇ. SUPERIOR ..... 29</p> <p>Op.27 PALLET ASSEMBLY UPPER POSITION / MONTAGGIO PALETTE POSIZ SUPERIORE / MONTAGE PLAQUES POS. SUPÉRIEURE / MONTAGE DER SCHAUFEL IN DER OBEREN POSITION / MONTAJE DE LAS PALETAS EN POSICIÓN SUP. / MONTAGEM DA PALETA POSIÇ. SUPERIOR ..... 30</p> <p>Op.28 MOUNTING OF PALLET CAPS / MONTAGGIO TAPPI PALETTE / MONTAGE DES OBTURATEURS DE PLAQUES / MONTAGE DER SCHAUFELKAPPEN / MONTAJE DE LOS TAPONES DE LAS PALETAS / MONTAGEM DE TAMPAS DE PALETA ..... 30</p> <p>Op.29 ASSEMBLY OF PALLETS LOWER POSITION / MONTAGGIO PALETTE POSIZIONE INF. / MONTAGE PLAQUES POSITION INF. / MONTAGE DER SCHAUFEL IN DER UNTEREN POSITION / MONTAJE DE LAS PALETAS EN POSICIÓN INF. / MONTAGEM DA PALETA DE POSIÇÃO INF. .... 31</p>	<p>Op.29 ASSEMBLY OF PALLETS LOWER POSITION / MONTAGGIO PALETTE POSIZIONE INF. / MONTAGE PLAQUES POSITION INF. / MONTAGE DER SCHAUFEL IN DER UNTEREN POSITION / MONTAJE DE LAS PALETAS EN POSICIÓN INF. / MONTAGEM DA PALETA DE POSIÇÃO INF. .... 31</p> <p>Op.30 CENTRAL STOP ASSEMBLY / ASSEMBLAGGIO BATTUTA CENTRALE / ASSEMBLAGE DE L'ARRÊT CENTRAL / ZUSAMMENBAU ZENTRALE ANSCHLAGGRUPPE / ENSAMBLAJE DE PERCUTOR CENTRAL / MONTAGEM DO CALÇO CENTRAL ..... 32</p> <p>Op.31 TIE ROD ASSEMBLY / ASSEMBLAGGIO TIRANTI / ASSEMBLAGE DES TIRANTS / ZUSAMMENBAU ZUGSTANGEN / ENSAMBLAJE DE LOS TIRANTES / MONTAGEM DE TIRANTES ..... 32</p> <p>Op.32 MOUNTING OF SPRINGS / MONTAGGIO MOLLE / MONTAGE DU RESSORT / EINBAU DER FEDERN / MONTAJE DE LOS MUELLES / MONTAGEM DE MOLAS ..... 33</p> <p>Op.33 SIDE PANELS FIXING / FISSAGGIO PANNELLI LATERALI / FIXATION DES PANNEAUX LATÉRAUX / BEFESTIGUNG DER SEITENPANELE / FIJACIÓN DE LOS PANELES LATERALES / FIXAÇÃO DOS PAINÉIS LATERAIS ..... 34</p> <p>Op.34 ACTUATOR ASSEMBLY / MONTAGGIO ATTUATORE / MONTAGE DE L'ACTIONNEUR / MONTAGE ANTRIEB / MONTAJE DEL ACTUADOR / MONTAGEM DO ATUADOR .... 35</p> <p>Op.35 AGS MOUNTING ON FAN / MONTAGGIO AGS SU VENTILATORE / MONTAGE DES AGS SUR LE VENTILATEUR / EINBAU DER AGS AUF DEM VENTILATOR / MONTAJE AGS EN EL VENTILADOR / MONTAGEM AGS NO VENTILADOR ..... 35</p> <p>Op.36 AGS MOUNTING ON FAN / MONTAGGIO AGS SU VENTILATORE / MONTAGE DES AGS SUR LE VENTILATEUR / EINBAU DER AGS AUF DEM VENTILATOR / MONTAJE AGS EN EL VENTILADOR / MONTAGEM AGS NO VENTILADOR ..... 36</p> <p>Op.37 AGS GRILLE MOUNTING (OPTIONAL) / MONTAGGIO GRIGLIA AGS (OPZIONALE) / MONTAGE GRILLE AGS (EN OPTION) / MONTAGE DES AGS-GITTERS (OPTIONAL) / MONTAJE REJILLA AGS (OPCIONAL) / MONTAGEM DA GRELHA AGS (OPCIONAL) ..... 36</p> <p>ASSEMBLY OF AIR EXTRACTION CONE UNIT ..... 37</p> <p>MONTAGGIO GRUPPO CONO DI SCARICO ARIA ..... 37</p> <p>MONTAGE DU GROUPE DU CÔNE D'ÉVACUATION DE L'AIR ..... 37</p> <p>MONTAGE LUFTAUSTRITTSKEGELINHEIT ..... 37</p> <p>MONTAJE GRUPO CONO DE SALIDA DE AIRE ..... 37</p> <p>MONTAGEM DO GRUPO DO CONE DE DESCARGA DE AR ..... 37</p> <p>Op.38 CONE BRACKETS MOUNTING / MONTAGGIO STAFFE CONO / MONTAGE DES ÉQUERRES DU CÔNE / MONTAGE DER KEGELHALTERUNGEN / MONTAJE DE LOS ESTIBOS DEL CONO / MONTAGEM DOS SUPORTES DO CONE ..... 37</p> <p>Op.39 CONE BRACKETS MOUNTING / MONTAGGIO STAFFE CONO / MONTAGE DES ÉQUERRES DU CÔNE / MONTAGE DER KEGELHALTERUNGEN / MONTAJE DE LOS ESTIBOS DEL CONO / MONTAGEM DOS SUPORTES DO CONE ..... 38</p> <p>Op.40 CONE MOUNTING / MONTAGGIO CONO / MONTAGE DU CÔNE / MONTAGE DES KEGELS / MONTAJE DEL CONO / MONTAGEM DO CONE ..... 38</p> <p>Op.41 MOUNTING OF CONE PROTECTION GRILLE / MONTAGGIO GRIGLIA PROTEZIONE CONO / MONTAGE GRILLE DE PROTECTION DU CÔNE / MONTAGE DES KEGELSCHUTZGITTERS / MONTAJE REJILLA DE PROTECCIÓN DEL CONO / MONTAGEM DA GRELHA DE PROTEÇÃO DO CONE ..... 39</p>
--	---

## Tools / Utensili / Ustensiles / Werkzeuge / Instrumentos / Ferramentas

	GB	I	F	D	E	P
	Pneumatic Screwriver	Avvitatore pneumatico	Tournevis pneu- matique	Pneumatischer Schraubenzieher	Atornillador neumático	Aparafusador pneumático
	8mm Spanner	Bussola 8mm	Boussole 8mm	8mm-Buchse	Buje 8mm	Soquete 8mm
	10mm Spanner	Bussola 10mm	Boussole 10mm	10mm-Buchse	Buje 10mm	Soquete 10mm
	13mm Spanner	Bussola 13mm	Boussole 13mm	13mm-Buchse	Buje 13mm	Soquete 13mm
	17mm Spanner	Bussola 17mm	Boussole 17mm	17mm-Buchse	Buje 17mm	Soquete 17mm
	32mm Spanner	Bussola 32mm	Boussole 32mm	32mm-Buchse	Buje 32mm	Soquete 32mm
	8mm Combina- tion Spanner	Chiave con- binata 8mm	Clé à molet- te 8mm	8mm-Ringmau- lschlüssel	Llave combi- nada 8mm	Chave combi- nada 8mm
	10mm Combina- tion Spanner	Chiave combi- nata 10mm	Clé à molet- te 10 mm	10mm-Ring- maulschlüssel	Llave combi- nada 10mm	Chave combi- nada 10mm
	13mm Combina- tion Spanner	Chiave combi- nata 13mm	Clé à molet- te 13 mm	13mm-Ring- maulschlüssel	Llave combi- nada 13mm	Chave combi- nada 13mm
	17mm Combina- tion Spanner	Chiave combi- nata 17mm	Clé à molet- te 17 mm	17mm-Ring- maulschlüssel	Llave combi- nada 17mm	Chave combi- nada 17mm
	Torque wrench	Chiave dina- mometrica	Clé dyna- mométrique	Drehmomentschlüssel	Llave dina- mométrica	Chave dina- mométrica
	Inserting Ma- chine	Insertatrice	Machine à in- sertion	Nieteinsetzmaschine	Retestadora	Máquina de inserção
	Philips Drive Bit	Inserto Philips	Insert Philips	Philips-Einsatz	Punta Philips	Ponta Philips
	Long Span- ner Adapter	Prolunga per Bussola	Extension de la boussole	Buchsenverlängerung	Alargador para buje	Extensão para Soquete
	Drill bit Ø 13mm	Punta da trapa- no Ø 13mm	Mèche Ø 13 mm	Bohrerspit- ze Ø 13mm	Taladro de Ø 13mm	Ponta de bro- ca Ø 13mm
	Riveting Ma- chine	Rivettatrice	Machine à riveter	Nietmaschine	Remachadora	Máquina de rebitar
	Allen key 6mm	Chiave a Brugola 6mm	Clé Allen 6mm	Inbusschlüssel 6mm	Llave Allen 6mm	Chave Allen 6mm
	Support (H=4Cm Min)	Supporto (H = 4Cm Min)	Support (H = 4cm min.)	Träger (H= 4Cm Min)	Soporte (H=4cm mín.)	Suporte (A = 4Cm Min)

<b>GB Bolt &amp; Nut</b>	HE	HP	DD	EC
M5x35 Hex Screw	4	4	4	4
M6x30 Hex Screw	4	4	0	0
M8x20 Hex Screw	0	0	0	4
M8x25 Hex Screw W/Flange	28	28	24	24
M8x50 Hex Screw	28	28	26	26
M8x30 Allen screw	4	4	4	4
M10x25 Hex Screw	0	0	1	1
M10x50 Hex Screw	0	0	4	0
M8x16 Hex Screw	0	0	0	4
M5 Self-Locking Nut	4	4	4	4
M25 Hex Nut	1	1	0	0
M6 Hex Nut W/Flange	4	4	0	0
M8 Hex Nut	4	4	0	0
M8 Hex Nut W/Flange	52	52	50	50
M10 Hex Nut	0	0	4	0
Ø8 Toothed Washer	4	4	0	4
Ø6x24 Washer	17	17	16	16
Ø8x24 Washer	30	30	34	34
Ø8x32 Washer	8	8	8	8
Ø10.5x21 Washer	0	0	8	0
Ø10x40 Washer	0	0	1	2
Ø10 Spring washer	0	0	1	1
Ø6.3x13 Self-Tapping Screw	32	32	32	32
Ø6.3x19 Self-Tapping Screw	33	33	32	32
Ø4.8x9 Pop Up Rivet	48	48	48	48
Ø6.4x12 Pop Up Rivet	50	50	50	50
M8x12.5 Threaded Bush	0	0	0	4
M8x17.5 Threaded Bush	4	4	4	4
Retaining ring	0	0	0	1

<b>I Viti e Dadi</b>	HE	HP	DD	EC
Vite TE M5x35	4	4	4	4
Vite TE M6x30	4	4	0	0
Vite TE M8x20	0	0	0	4
Vite TE con flangia M8x25	28	28	24	24
Vite TE M8x50	28	28	26	26
Vite TCEI M8x30	4	4	4	4
Vite TE M10x25	0	0	1	1
Vite TE M10x50	0	0	4	0
Vite TE M8x16	0	0	0	4
Dado Autobloccante M5	4	4	4	4
Dado esagonale M25	1	1	0	0
Dado esagonale con flangia M6	4	4	0	0
Dado esagonale M8	4	4	0	0
Dado esagonale con flangia M8	52	52	50	50
Dado esagonale M10	0	0	4	0
Rondella dentellata Ø8	4	4	0	4
Rondella Ø6x24	17	17	16	16
Rondella Ø8x24	30	30	34	34
Rondella Ø8x32	8	8	8	8
Rondella D10.5x21	0	0	8	0
Rondella D10x40	0	0	1	2
Rondella elastica D10	0	0	1	1
Vite autofilettante Ø6.3x13	32	32	32	32
Vite autofilettante Ø6.3x19	33	33	32	32
Rivetto Ø4.8x9	48	48	48	48
Rivetto Ø6.4x12	50	50	50	50
Boccola filettata M8x12.5	0	0	0	4
Boccola filettata M8x17.5	4	4	4	4
Anello di ritegno	0	0	0	1

**F** Vis et écrous

	HE	HP	DD	EC
Vis TE M5x35	4	4	4	4
Vis TE M6x30	4	4	0	0
Vis TE M8x20	0	0	0	4
Vis TE avec bride M8x25	28	28	24	24
Vis TE M8x50	28	28	26	26
Vis TCEI M8x30	4	4	4	4
Vis TE M10x25	0	0	1	1
Vis TE M10x50	0	0	4	0
Vis TE M8x16	0	0	0	4
Écrou autobloquant M5	4	4	4	4
Écrou hexagonal M25	1	1	0	0
Écrou hexagonal avec bride M6	4	4	0	0
Écrou hexagonal M8	4	4	0	0
Écrou hexagonal avec bride M8	52	52	50	50
Écrou hexagonal M10	0	0	4	0
Rondelle Dentée Ø8	4	4	0	4
Rondelle Ø6x24	17	17	16	16
Rondelle Ø8x24	30	30	34	34
Rondelle Ø8x32	8	8	8	8
Rondelle D10.5x21	0	0	8	0
Rondelle D10x40	0	0	1	2
Rondelle élastique Ø10	0	0	1	1
Vis autofiletante Ø6.3x13	32	32	32	32
Vis autotaraudeuse Ø6.3x13	33	33	32	32
Rivet Ø4.8x9	48	48	48	48
Rivet Ø6.4x12	50	50	50	50
Bague fileté M8x12.5	0	0	0	4
Bague fileté M8x17.5	4	4	4	4
Anneau de retenue	0	0	0	1

**D** Schrauben und Schraubenmuttern

	HE	HP	DD	EC
TE-Schraube M5x35	4	4	4	4
TE-Schraube M6x30	4	4	0	0
TE-Schraube M8x20	0	0	0	4
TE-Schraube mit Flansch M8x25	28	28	24	24
TE-Schraube M8x50	28	28	26	26
Innensechskantschraube M8x30	4	4	4	4
TE-Schraube M10x25	0	0	1	1
TE-Schraube M10x50	0	0	4	0
TE-Schraube M8x16	0	0	0	4
Selbstsichernde Mutter M5	4	4	4	4
Sechskantmutter M25	1	1	0	0
Sechskantmutter mitFlansch M6	4	4	0	0
Sechskantmutter M8	4	4	0	0
Sechskantmutter mitFlansch M8	52	52	50	50
Sechskantmutter M10	0	0	4	0
Zahnscheibe Ø8	4	4	0	4
Unterlegscheibe Ø6x24	17	17	16	16
Unterlegscheibe Ø8x24	30	30	34	34
Unterlegscheibe Ø8x32	8	8	8	8
Rondella D10.5x21	0	0	8	0
Rondella D10x40	0	0	1	2
Elastische Unterlegscheibe Ø10	0	0	1	1
Selbstschneidende Schraube Ø6,3x13	32	32	32	32
Selbstschneidende Schraube Ø6,3x19	33	33	32	32
Niet Ø4.8x9	48	48	48	48
Niet Ø6.4x12	50	50	50	50
Gewindebuchse M8x12.5	0	0	0	4
Gewindebuchse M8x17.5	4	4	4	4
Sicherungsring	0	0	0	1



<b>E</b> Tornillos y tuercas	HE	HP	DD	EC
Tornillo de cabeza hexagonal M5x35	4	4	4	4
Tornillo de cabeza hexagonal M6x30	4	4	0	0
Tornillo de cabeza hexagonal M8x20	0	0	0	4
Tornillo de cabeza hexagonal con brida M8x25	28	28	24	24
Tornillo de cabeza hexagonal M8x50	28	28	26	26
Tornillo allen M8x30	4	4	4	4
Tornillo de cabeza hexagonal M10x25	0	0	1	1
Tornillo de cabeza hexagonal M10x50	0	0	4	0
Tornillo de cabeza hexagonal M8x16	0	0	0	4
Tuerca autoblocante M5	4	4	4	4
Tuerca hexagonal M25	1	1	0	0
Tuerca hexagonal con brida M6	4	4	0	0
Tuerca hexagonal M8	4	4	0	0
Tuerca hexagonal con brida M8	52	52	50	50
Tuerca hexagonal M10	0	0	4	0
Arandela Dentada Ø8	4	4	0	4
Arandela Ø6x24	17	17	16	16
Arandela Ø8x24	30	30	34	34
Arandela Ø8x32	8	8	8	8
Arandela Ø10.5x21	0	0	8	0
Arandela Ø10x40	0	0	1	2
Arandela elástica Ø10	0	0	1	1
Tornillo autorroscante Ø6.3x13	32	32	32	32
Tornillo autorroscante Ø6.3x19	33	33	32	32
Remache Ø4.8x9	48	48	48	48
Remache Ø6.4x12	50	50	50	50
Casquillo roscado M8x12.5	0	0	0	4
Casquillo roscado M8x17.5	4	4	4	4
Anillo de retención	0	0	0	1

<b>P</b> Parafusos e porcas	HE	HP	DD	EC
Parafuso TE M5x35	4	4	4	4
Parafuso TE M6x30	4	4	0	0
Parafuso TE M8x20	0	0	0	4
Parafuso TE com flange M8x25	28	28	24	24
Parafuso TE M8x50	28	28	26	26
Parafuso Allen M8x30	4	4	4	4
Parafuso TE M10x25	0	0	1	1
Parafuso TE M10x50	0	0	4	0
Parafuso TE M8x16	0	0	0	4
Porca auto-bloqueante M5	4	4	4	4
Porca hexagonal M25	1	1	0	0
Porca hexagonal com flange M6	4	4	0	0
Porca hexagonal M8	4	4	0	0
Porca hexagonal com flange M8	52	52	50	50
Porca hexagonal M10	0	0	4	0
Arruela Serrilhada Ø8	4	4	0	4
Anilha Ø6x24	17	17	16	16
Anilha Ø8x24	30	30	34	34
Anilha Ø8x32	8	8	8	8
Anilha Ø10.5x21	0	0	8	0
Anilha Ø10.5x40	0	0	1	2
Anilha elástica Ø10	0	0	1	1
Parafuso autorroscante Ø6.3x13	32	32	32	32
Parafuso autorroscante Ø6.3x19	33	33	32	32
Rebite Ø4.8x9	48	48	48	48
Rebite Ø6.4x12	50	50	50	50
Bucha roscada M8x12,5	0	0	0	4
Bucha roscada M8x17,5	4	4	4	4
Anel de retenção	0	0	0	1

- GB** BODY AND MOTOR ASSEMBLY
- I** ASSEMBLAGGIO CARROZZERIA E MOTORE
- F** ASSEMBLAGE CARROSSERIE ET MOTEUR
- D** ZUSAMMENBAU VON AUFBAU UND MOTOR
- E** ENSAMBLAJE DE LA CARROCEÍA Y DEL MOTOR
- P** MONTAGEM DO CORPO E DO MOTOR

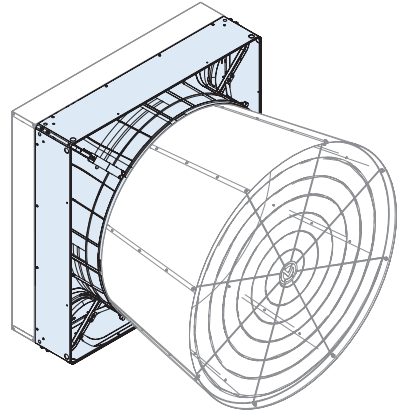

# Op.01 Superstructure Assembly / Assemblaggio superstruttura / Montage Structure Supérieure / Zusammenbau Der Superstruktur/Ensamblaje De La Superestructura / Montagem Da Superestruturura



Tools/Utensili/Utensiles/Werkzeuge /Instrumentos/Ferramentas

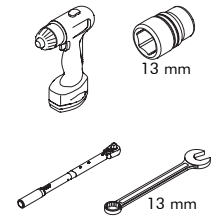

Bolts & Nuts/Viti e dadi/Vis et écrous /Schrauben und Schraubenmuttern/ Tornillos y tuercas/Parafusos e porcas

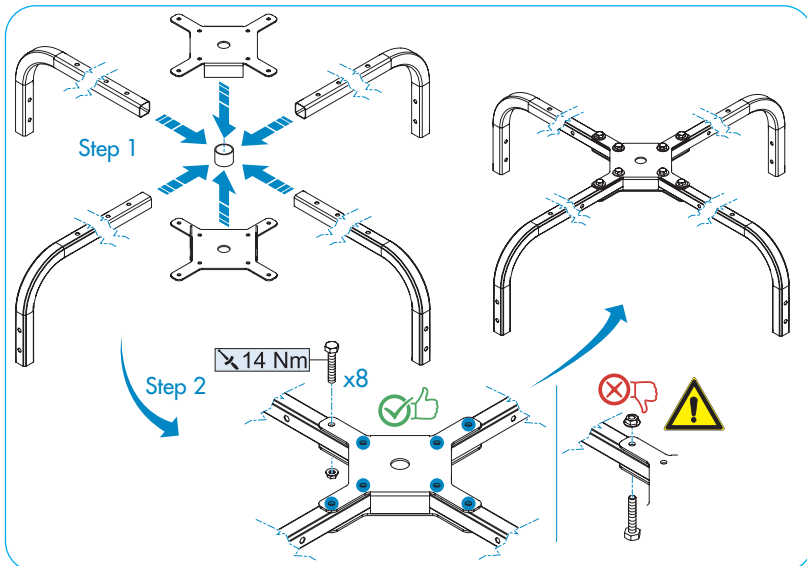
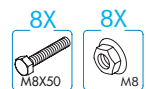

Op.01 Superstructure Assembly / Assemblaggio superstruttura / Montage Structure Supérieure / Zusammenbau Der Superstruktur/Ensamblaje De La Superestructura / Montagem Da Superestrutura

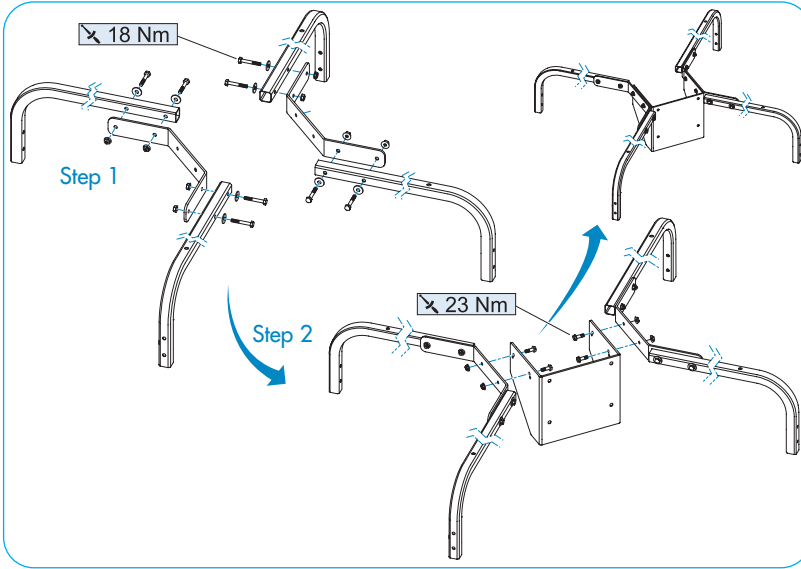

Tools/Utensili/Utensiles/Werkzeuge / Instrumentos/Ferramentas

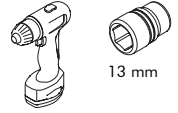

Bolts & Nuts/Viti e dadi/Vis et écrous / Schrauben und Schraubenmuttern / Tornillos y tuercas/Parafusos e porcas

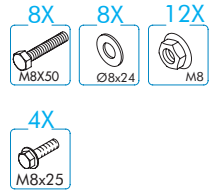

Op.01 Superstructure Assembly / Assemblaggio superstruttura / Montage Structure Supérieure / Zusammenbau Der Superstruktur/Ensamblaje De La Superestructura / Montagem Da Superestrutura

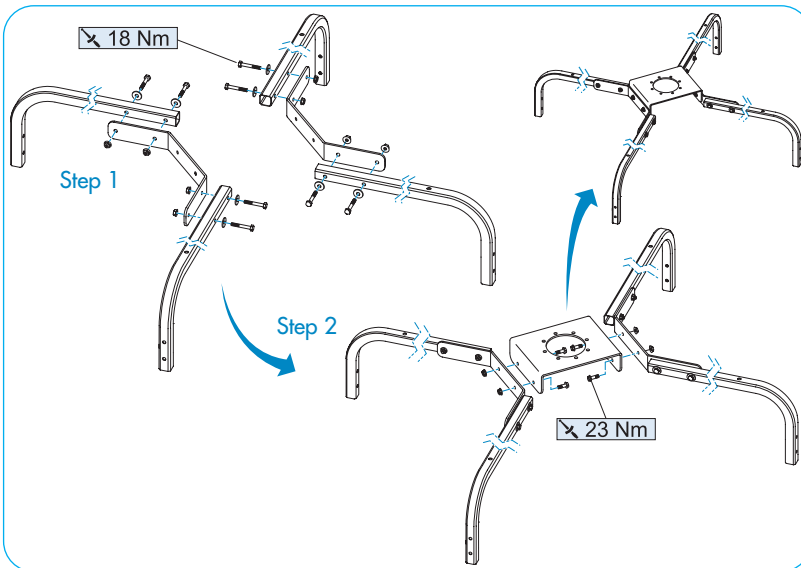

Tools/Utensili/Utensiles/Werkzeuge / Instrumentos/Ferramentas

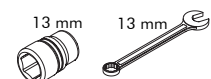
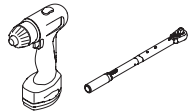

Bolts & Nuts/Viti e dadi/Vis et écrous / Schrauben und Schraubenmuttern / Tornillos y tuercas/Parafusos e porcas

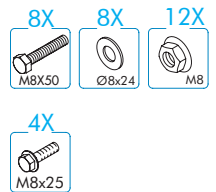

# Op.02 Hub assembly / Assemblaggio mozzo / Assemblage du moyeu / Montage der Nabe / Ensamblaje del portabuje / Montagem do cubo



Tools/Utensili/Utensiles/Werkzeuge / Instrumentos/Ferramentas

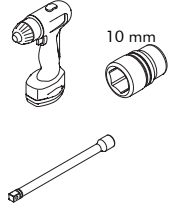

Bolts & Nuts/Viti e dadi/Vis et écrous / Schrauben und Schraubenmutter/ Tornillos y tuercas/Parafusos e porcas

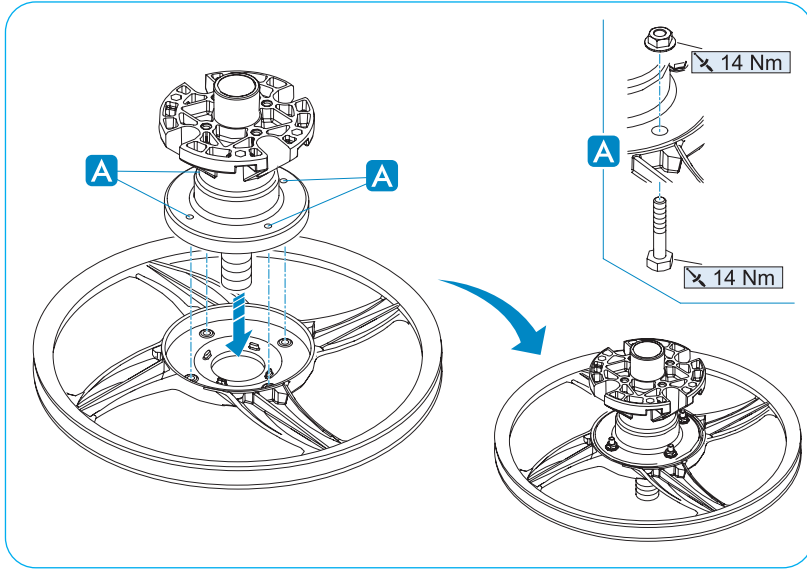
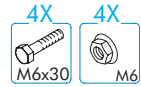

# Op.03 Hub fixing on structure / Fissaggio mozzo su struttura / Fixation du moyeu sur la structure / Befestigung der Nabe an der Struktur / Fijación del portabuje sobre la estructura / Fixação do cubo à estrutura



Tools/Utensili/Utensiles/Werkzeuge / Instrumentos/Ferramentas

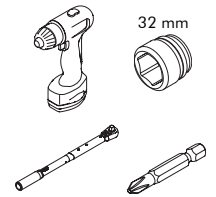

Bolts & Nuts/Viti e dadi/Vis et écrous / Schrauben und Schraubenmutter/ Tornillos y tuercas/Parafusos e porcas

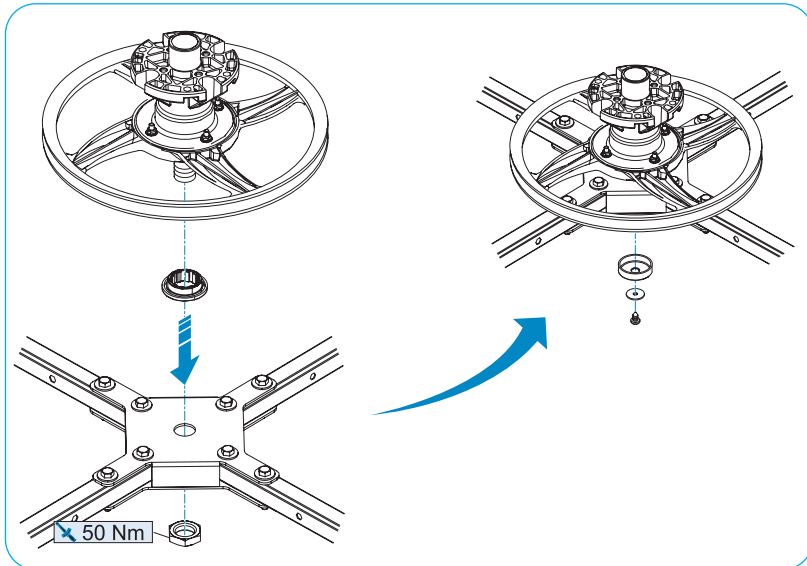
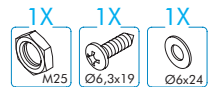

## Op.04 Conveyor assembly / Assemblaggio convogliatore / Assemblage du convoyeur / Montage der Förderer-Baugruppe / Ensamblaje del transportador / Montagem da transportadora

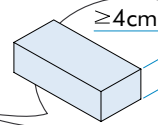
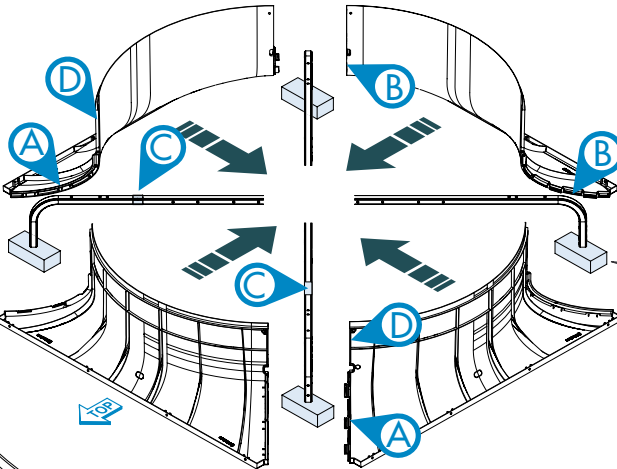
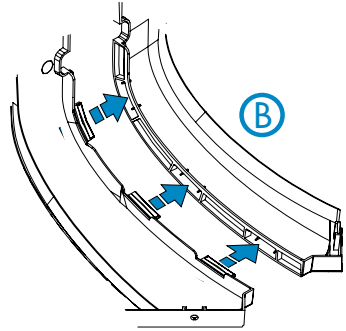
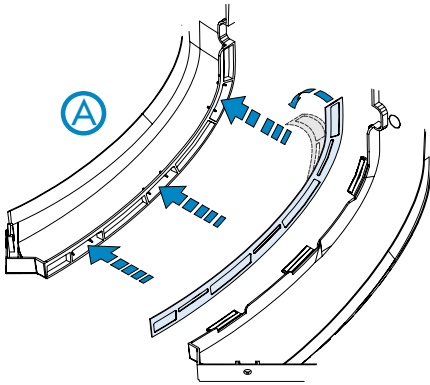

Not Supplied  
Non fornito  
Non fourni  
Nicht vorgesehen  
No suministrado  
Não Fornecido

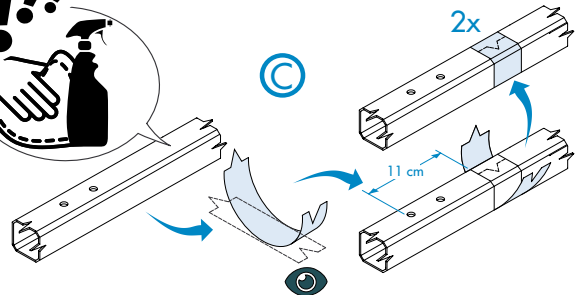
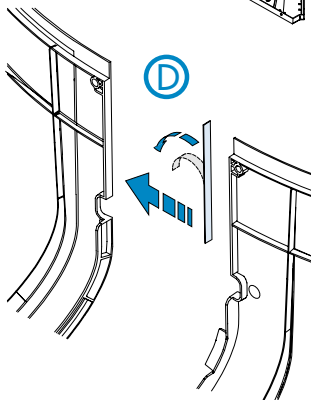

## Op.05 Conveyor fixing on structure/Fissaggio convogliatore su struttura/Fixation du convoyeur sur la structure/Befestigung des Förderers an der Struktur/Fijación del transportador sobre la estructura/Fixação da transportadora

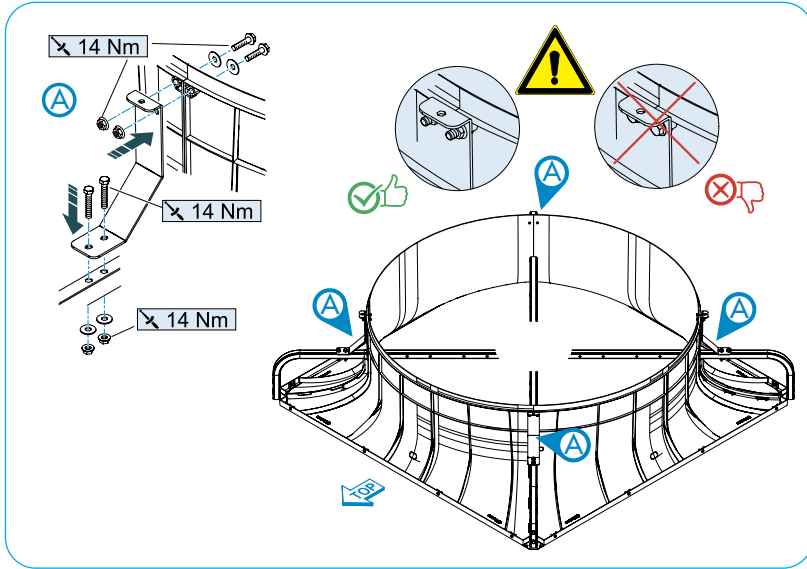

Tools/Utensili/Utensiles/Werkzeuge /Instrumentos/Ferramentas

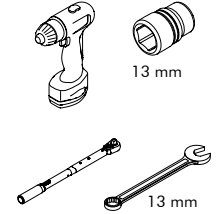

Bolts & Nuts/Viti e dadi/Vis et écrous /Schrauben und Schraubenmuttern/ Tornillos y tuercas/Parafusos e porcas

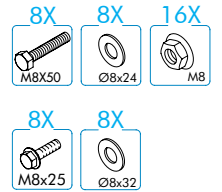

## Op.06 Reinforcement bracket fixing/Fissaggio staffa di rinforzo/Fixation de l'équerre de renforcement/Befestigung von Verstärkungsbügeln/Fijación del estribo de refuerzo/Fixação da haste de reforço

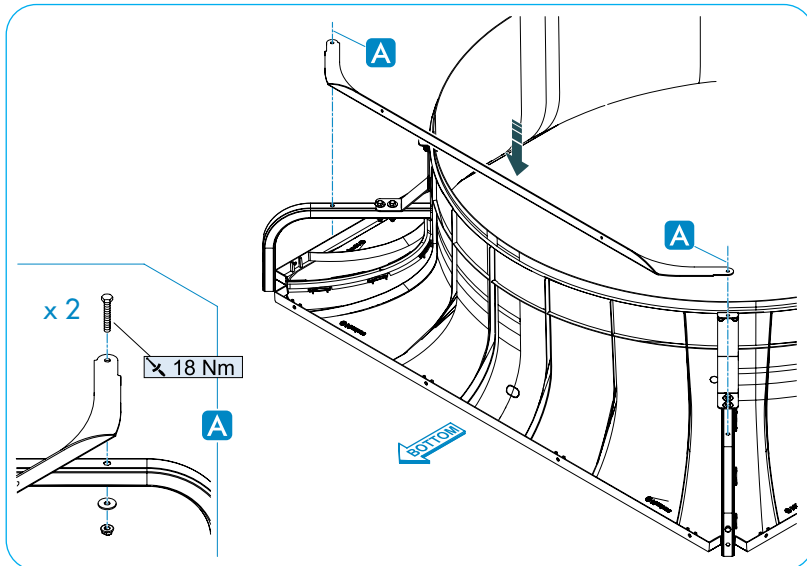

Tools/Utensili/Utensiles/Werkzeuge /Instrumentos/Ferramentas

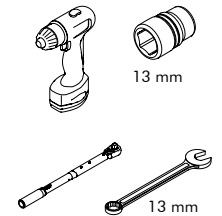

Bolts & Nuts/Viti e dadi/Vis et écrous /Schrauben und Schraubenmuttern/ Tornillos y tuercas/Parafusos e porcas

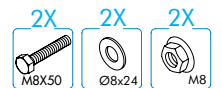

Op.07 Panel assembly / Assemblaggio pannelli / Assemblage des panneaux / Paneel-Montage / Ensamblaje de los paneles / Montagem dos painéis



Tools/Utensili/Utensiles/Werkzeuge / Instrumentos/Ferramentas



Bolts & Nuts/Viti e dadi/Vis et écrous / Schrauben und Schraubenmüttern / Tornillos y tuercas/Parafusos e porcas

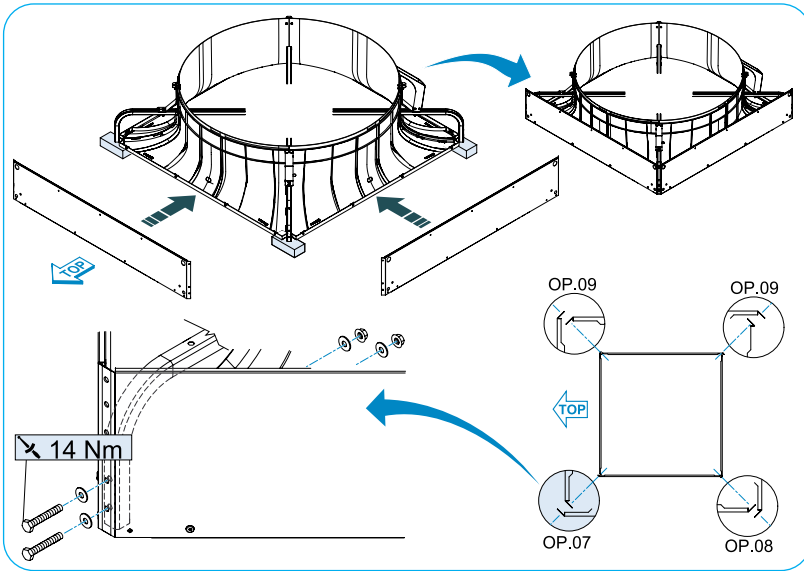
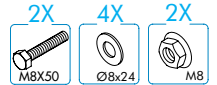

Op.08 Panel assembly / Assemblaggio pannelli / Assemblage des panneaux / Paneel-Montage / Ensamblaje de los paneles / Montagem dos painéis



Tools/Utensili/Utensiles/Werkzeuge / Instrumentos/Ferramentas

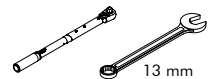
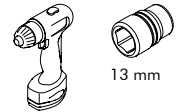

Bolts & Nuts/Viti e dadi/Vis et écrous / Schrauben und Schraubenmüttern / Tornillos y tuercas/Parafusos e porcas

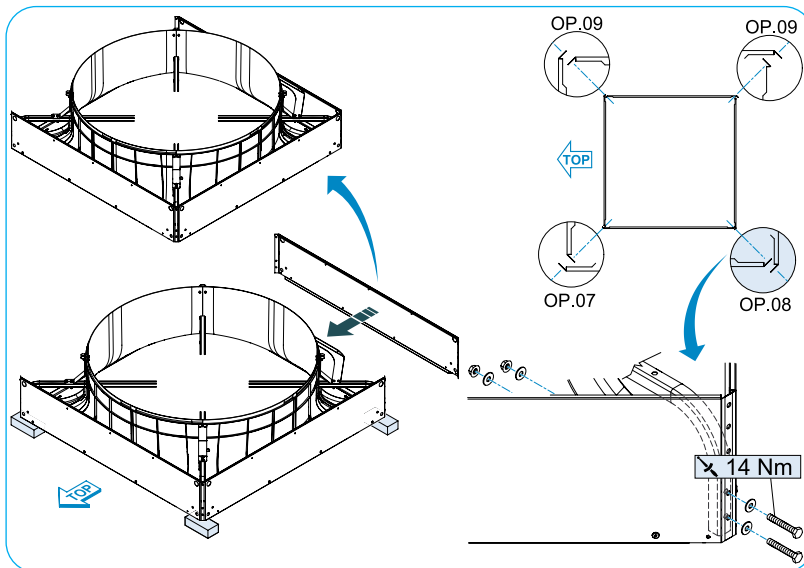
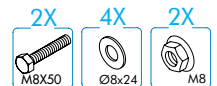

# Op.09 Panel assembly / Assemblaggio pannelli / Assemblage des panneaux / Paneel-Montage / Ensamblaje de los paneles / Montagem dos painéis



Tools / Utensili / Ustensiles / Werkzeuge / Instrumentos / Ferramentas

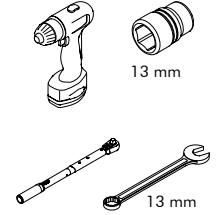

Bolts & Nuts / Viti e dadi / Vis et écrous / Schrauben und Schraubenmuttern / Tornillos y tuercas / Parafusos e porcas

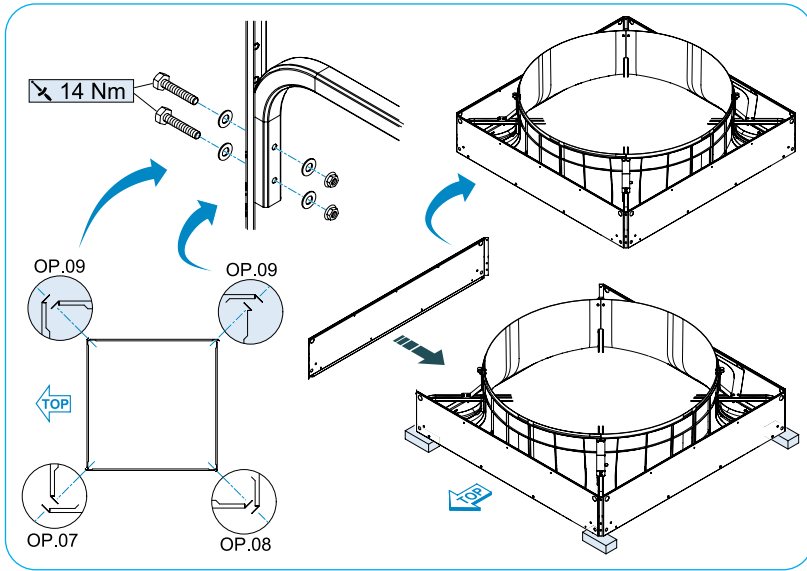
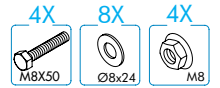

# Op.10 Angle Brackets Mounting / Montaggio Staffe angolari / Montage des équerres d'angle / Montage Winkelhalterungen / Montaje de los estribos angulares / Montagem de suportes angulares



Tools / Utensili / Ustensiles / Werkzeuge / Instrumentos / Ferramentas

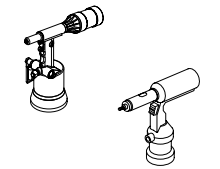

Bolts & Nuts / Viti e dadi / Vis et écrous / Schrauben und Schraubenmuttern / Tornillos y tuercas / Parafusos e porcas

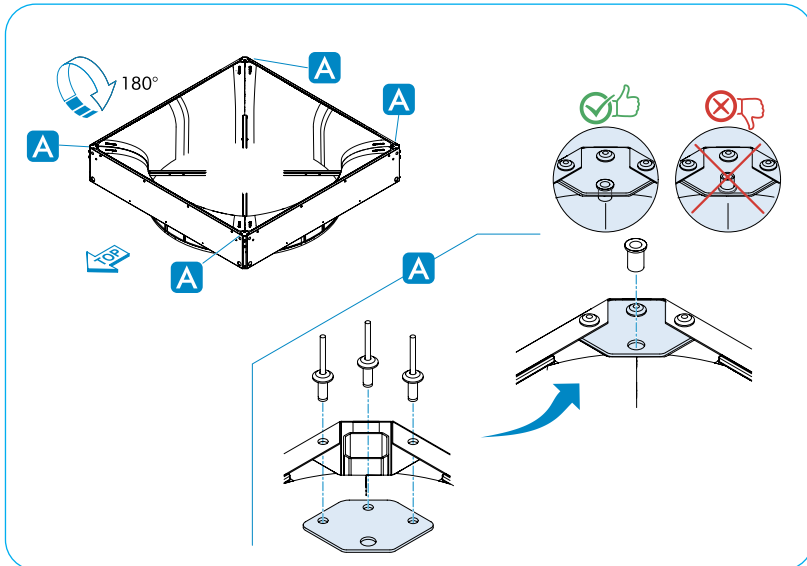
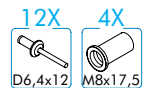



Op. 11 Panel assembly / Assemblaggio pannelli / Assemblage des panneaux / Paneel-Montage / Ensamblaje de los paneles / Montagem dos painéis/montaggio profilo dell'oscurante



Tools/Utensili/Utensiles/Werkzeuge / Instrumentos/Ferramentas

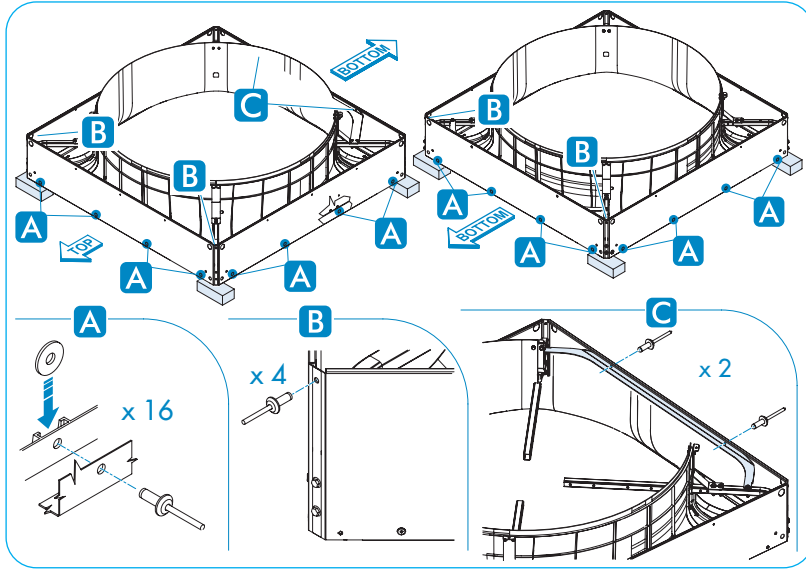

Bolts & Nuts/Viti e dadi/Vis et écrous /Schrauben und Schraubenmüttern/ Tornillos y tuercas/Parafusos e porcas

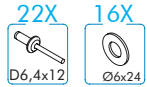

Op. 12 Assembly of motor supports / Assemblaggio supporti motore / Assemblage supports moteur / Montage von Motorträgern/Ensamblaje de los soportes para el motor / Montagem dos suportes do motor



Tools/Utensili/Utensiles/Werkzeuge / Instrumentos/Ferramentas

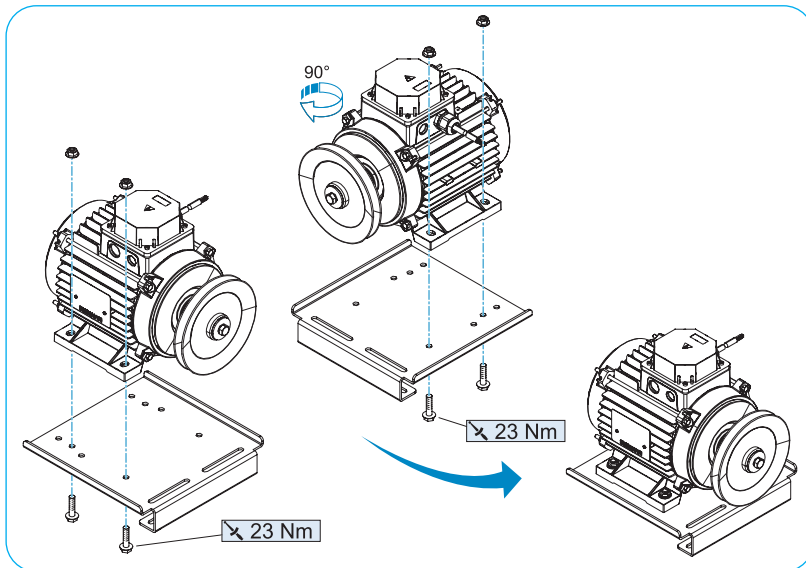
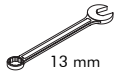

Bolts & Nuts/Viti e dadi/Vis et écrous /Schrauben und Schraubenmüttern/ Tornillos y tuercas/Parafusos e porcas

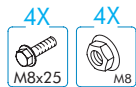

# Op.13 Motor Mounting / Montaggio Motore / Montage du moteur / Montage des Motors / Montaje del motor / Montagem do motor



Tools/Utensili/Utensiles/Werkzeuge / Instrumentos/Ferramentas

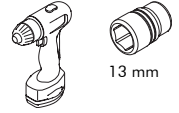

13 mm

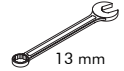

13 mm

Bolts & Nuts/Viti e dadi/Vis et écrous /Schrauben und Schraubenmutter/ Tornillos y tuercas/Parafusos e porcas

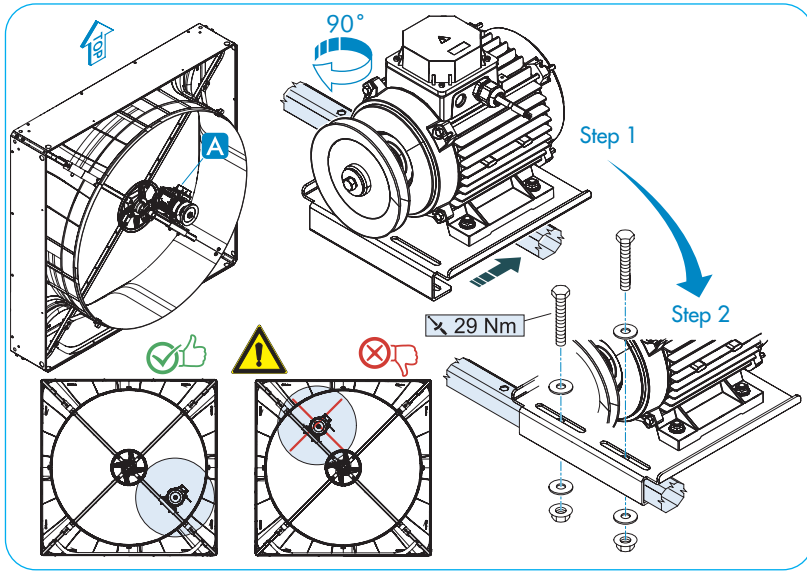
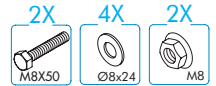

# Op.13 Motor Mounting / Montaggio Motore / Montage du moteur / Montage des Motors / Montaje del motor / Montagem do motor



Tools/Utensili/Utensiles/Werkzeuge / Instrumentos/Ferramentas



17 mm

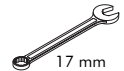

17 mm

Bolts & Nuts/Viti e dadi/Vis et écrous /Schrauben und Schraubenmutter/ Tornillos y tuercas/Parafusos e porcas

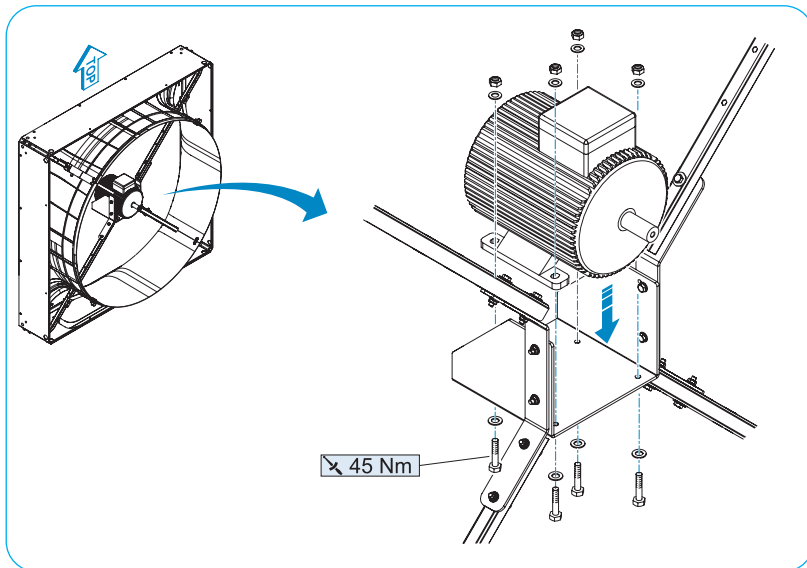

Op. 13 Motor Mounting / Montaggio Motore / Montage du moteur / Montage des Motors / Montaje del motor / Montagem do motor



Tools/Utensili/Utensiles/Werkzeuge / Instrumentos/Ferramentas



10 mm

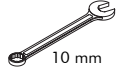

10 mm

Bolts & Nuts/Viti e dadi/Vis et écrous /Schrauben und Schraubenmüttern/ Tornillos y tuercas/Parafusos e porcas

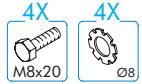

4X

M8x20

4X

Ø8

23 Nm

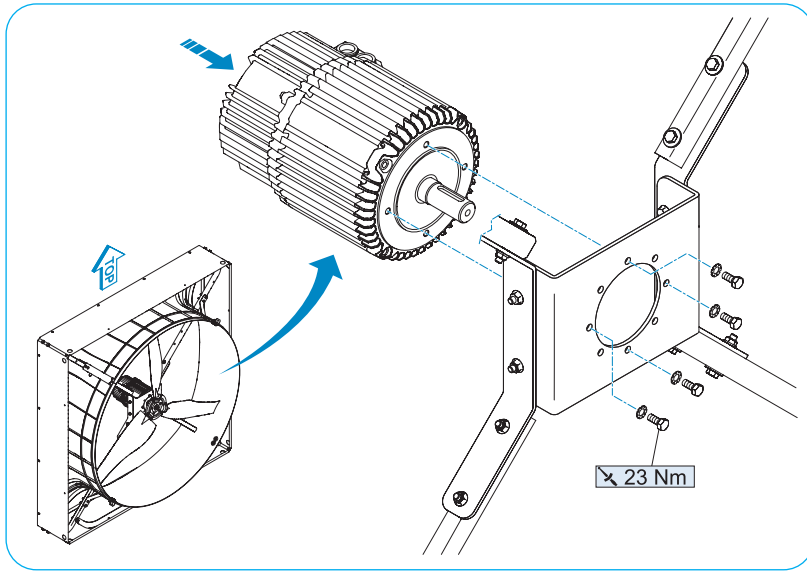

Op. 14 Condensate drain and fairlead/Scarico condensa e passacavo/Écoulement des condensats et presse-étoupe/Kondensatablauf und Kabelverschraubung/Escape condensación y pasacables/Descarga de condensação e ilhó



Tools/Utensili/Utensiles/Werkzeuge / Instrumentos/Ferramentas

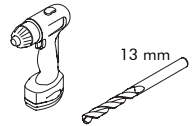

13 mm

- ⚠ PERFORATE THE CONVEYOR ONLY IF NECESSARY. USE CAUTION WHEN BREAKING MARKED PART.
- ⚠ FORARE IL CONVOIGLIATORE SOLO SE NECESSARIO. USARE CAUTELA NEL ROMPERE LE PARTI MARCATE.
- ⚠ FORER LE CONVOYEUR UNIQUEMENT SI NECESSAIRE. SOYEZ PRUDENT LORSQUE VOUS CASSEZ DES PIÈCES MARQUÉES.
- ⚠ BOHREN SIE DEN FÖRDERER NUR BEI BEDARF AN. VORSICHT BEIM BRECHEN MARKIERTER TEILE.
- ⚠ PERFORE EL TRANSPORTADOR SOLO SI ES NECESARIO. PRESTE ATENCIÓN AL ROMPER LAS PARTES MARCADAS.
- ⚠ PERFLURAR O TRANSPORTADOR APENAS SE NECESSÁRIO. CUIDADO AO ROMPER AS PARTES MARCADAS.

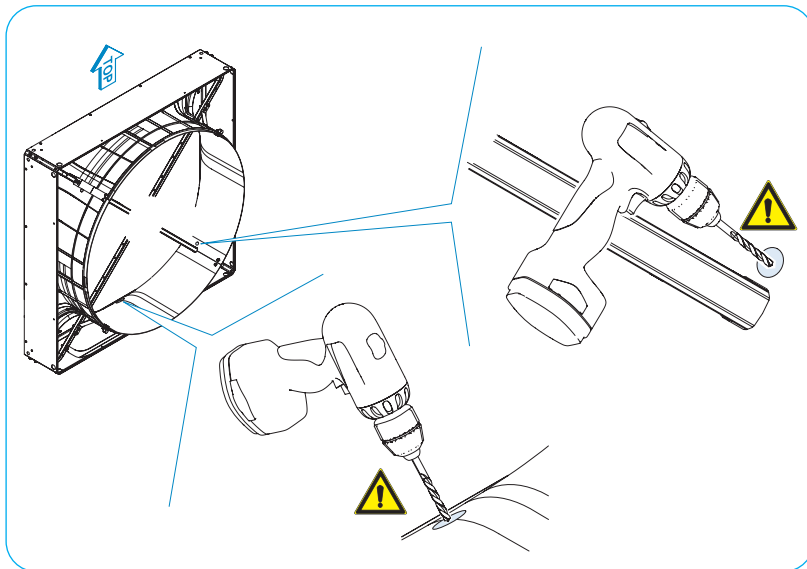

# Op. 15

Transmission belt mounting / Montaggio cinghia trasmissione / Montage de la courroie de transmission / Montage des Antriebsriemens / Montaje de la correa de transmisión / Montagem da correa de transmissão



Tools / Utensili / Ustensiles / Werkzeuge / Instrumentos / Ferramentas

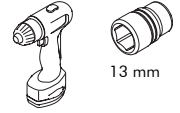

13 mm

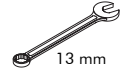

13 mm

Bolts & Nuts / Viti e dadi / Vis et écrous / Schrauben und Schraubenmutter / Tornillos y tuercas / Parafusos e porcas

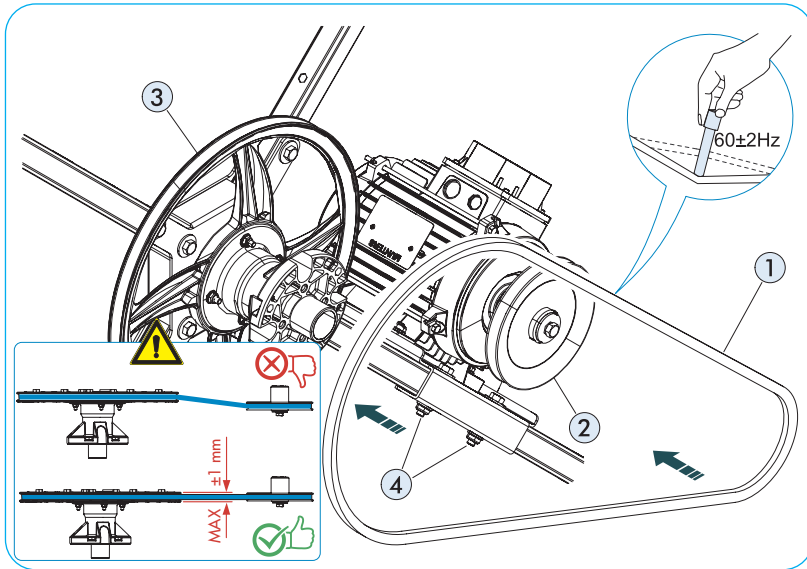

Place v-belt (1) on the pulleys (2) and (3) and then rotate the propeller clockwise in order to tighten the v-belt on the pulleys. Check tensioning: right tensioning is obtained when tension over the v-belt corresponds to a resonance frequency of  $60 \pm 2$  Hz measured by a v-belt tension meter like the "Trummy 2" manufactured by Fag or the "Ten-Sit" manufactured by Sit.



Positionieren Sie den Keilriemen (1) auf die Riemenscheiben (2) und (3), und drehen Sie dann den Propeller im Uhrzeigersinn, um die Keilriemen auf Riemenscheiben festzuziehen. Prüfen Sie die Spannung: die richtige Spannung ist erreicht, wenn die Keilriemenspannung einer Resonanzfrequenz von  $60 \pm 2$  Hz entspricht, die von einem Spannungsmessgerät für Keilriemen, wie dem "Trummy 2", von Fag oder dem "Ten-Sit" von Sit gemessen wurde.



Posizionare la cinghia trapezoidale (1) sulle pulegge (2) e (3), quindi ruotare l'elica in senso orario per stringere la cinghia trapezoidale sulle pulegge. Controllare il tensionamento: il corretto tensionamento si ottiene quando la tensione sulla cinghia trapezoidale corrisponde a una frequenza di risonanza di  $60 \pm 2$  Hz ottenuta da un misuratore di tensione per cinghie trapezoidali come il "Trummy 2" prodotto da Fag o il "Ten-Sit" prodotto da Sit.



Posicione la correa trapezoidal (1) sobre las poleas (2) y (3) y rote la hélice en sentido contrario a las agujas del reloj para apretar la correa trapezoidal a las poleas. Compruebe el tensado: el tensado correcto se obtiene cuando la tensión sobre la correa trapezoidal corresponde con una frecuencia de resonancia de  $60 \pm 2$  Hz obtenida por un medidor de tensión para correas trapezoidales como el "Trummy 2" producido por Fag o el "Ten-Sit" producido por Sit.



Placer la courroie trapézoïdale (1) sur les poulies (2) et (3), puis tourner l'hélice dans le sens horaire pour tendre la courroie trapézoïdale sur les poulies. Contrôler la tension : la bonne tension s'obtient lorsque la tension sur la courroie trapézoïdale correspond à une fréquence de résonance de  $60 \pm 2$  Hz obtenue par un tensiomètre pour les courroies trapézoïdales tel que le "Trummy 2" produit par Fag ou le "Ten-Sit" produit par Sit.



Posicionar a correa trapezoidal (1) nas polias (2) e (3), e depois rodar a hélice em sentido horário para apertar a correa trapezoidal nas polias. Verificar a tensão: a tensão correta obtém-se quando a tensão na correa trapezoidal corresponde a uma frequência de ressonância de  $60 \pm 2$  Hz obtida por um medidor de tensão para correias trapezoidais como o "Trummy 2" produzido pela Fag ou o "Ten-Sit" produzido pela Sit.

Op. 16 Fan mounting / Montaggio ventola / Montage du ventilateur / Montage des Lüfters /  
Montaje del ventilador / Montagem da ventoinha

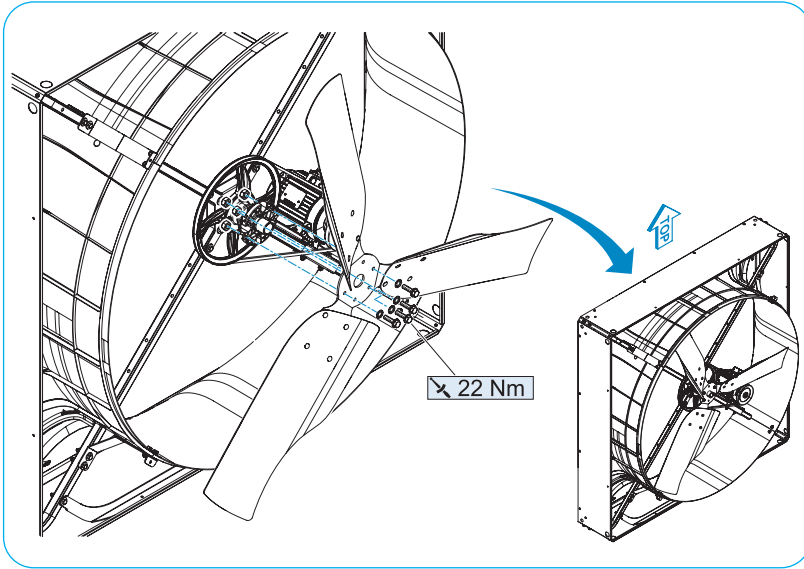

Tools/Utensili/Utensiles/Werkzeuge /  
Instrumentos/Ferramentas



13 mm



Bolts & Nuts/Viti e dadi/Vis et écrous /  
Schrauben und Schraubenmuttern/  
Tornillos y tuercas/Parafusos e porcas

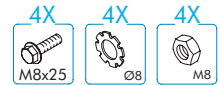

Op. 16 Fan mounting / Montaggio ventola / Montage du ventilateur / Montage des Lüfters /  
Montaje del ventilador / Montagem da ventoinha

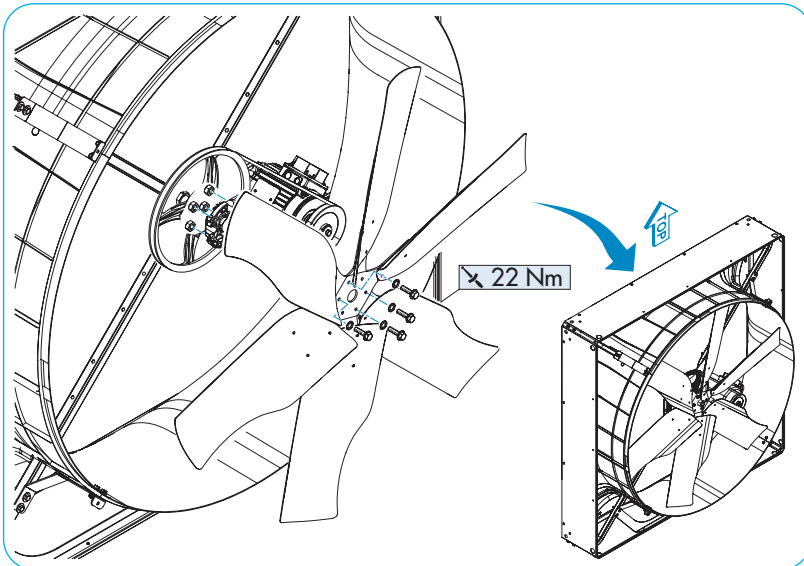

Tools/Utensili/Utensiles/Werkzeuge /  
Instrumentos/Ferramentas

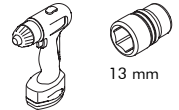

13 mm



Bolts & Nuts/Viti e dadi/Vis et écrous /  
Schrauben und Schraubenmuttern/  
Tornillos y tuercas/Parafusos e porcas

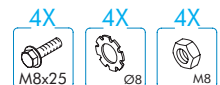

**Op. 16** Fan mounting / Montaggio ventola / Montage du ventilateur / Montage des Lüfters /  
Montaje del ventilador / Montagem da ventoinha

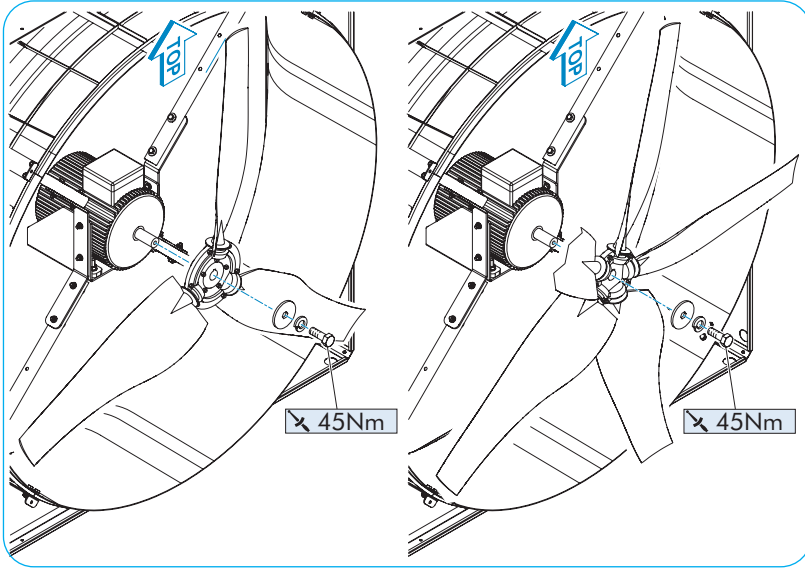

Tools/Utensili/Utensiles/Werkzeuge /  
Instrumentos/Ferramentas



17 mm



Bolts & Nuts/Viti e dadi/Vis et écrous  
/Schrauben und Schraubenmuttern/  
Tornillos y tuercas/Parafusos e porcas



**Op. 16** Fan mounting / Montaggio ventola / Montage du ventilateur / Montage des Lüfters /  
Montaje del ventilador / Montagem da ventoinha

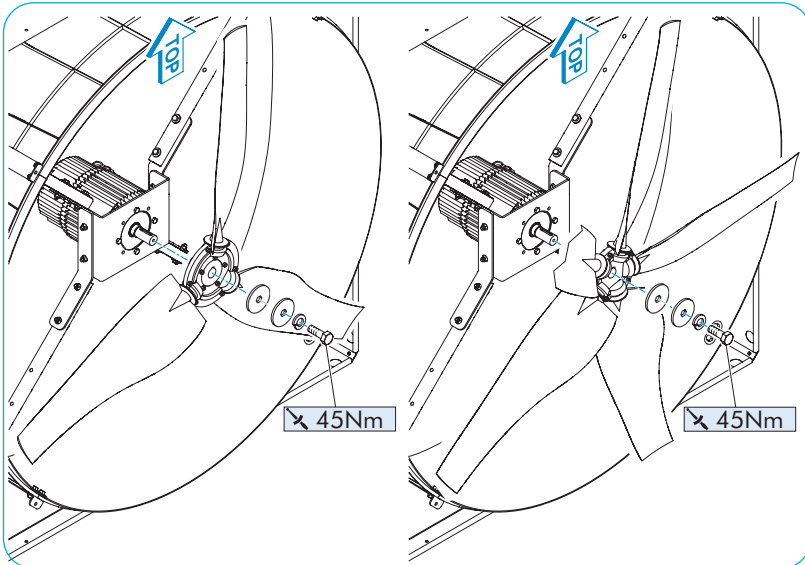

Tools/Utensili/Utensiles/Werkzeuge /  
Instrumentos/Ferramentas



13 mm



Bolts & Nuts/Viti e dadi/Vis et écrous  
/Schrauben und Schraubenmuttern/  
Tornillos y tuercas/Parafusos e porcas

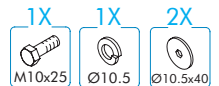

**GB** AGS SHUTTER ASSEMBLY

**I** ASSEMBLAGGIO SERRANDA AGS

**F** ASSEMBLAGE ENSEMBLE AMORTISSEUR AGS

**D** ZUSAMMENBAU DER AGS-KLAPPE

**E** ENSAMBLAJE DE LA PERSIANA AGS

**P** MONTAGEM DO REVESTIMENTO AGS

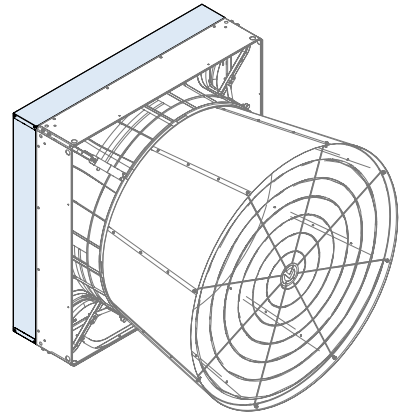

**Op. 17** AGS structure assembly / Assemblaggio pannelli AGS / Assemblage de la structure AGS /  
Zusammenbau der AGS-Struktur / Ensamblaje estructura AGS / Montagem da estrutura  
AGS

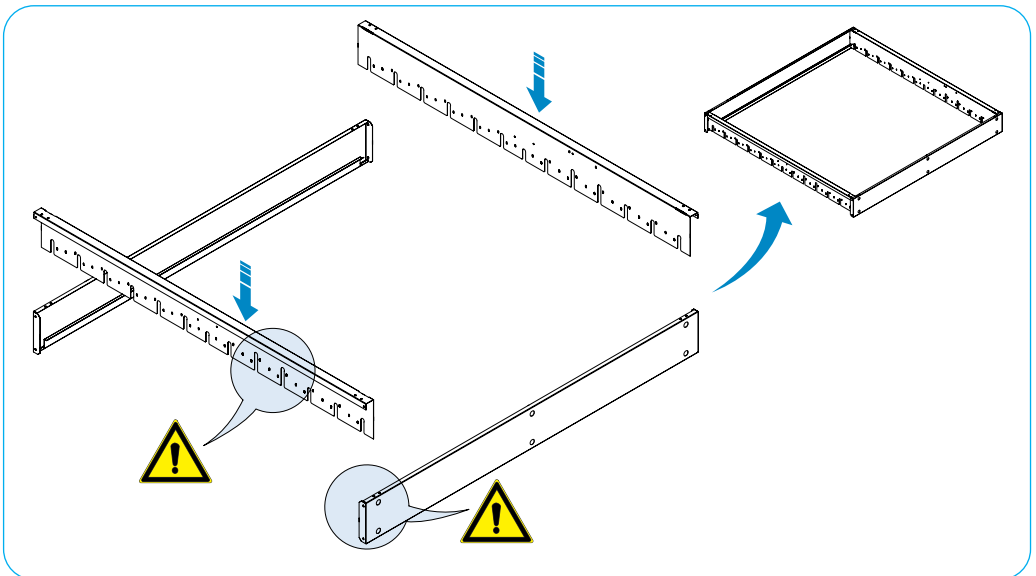

# Op.18 Plates assembly / Assemblaggio piastre / Assemblage des plaques / Zusammenbau der Platten / Ensamblaje de las placas / Montagem de placas (High Efficiency - Direct drive - High Pressure)



Tools / Utensili / Ustensiles / Werkzeuge / Instrumentos / Ferramentas

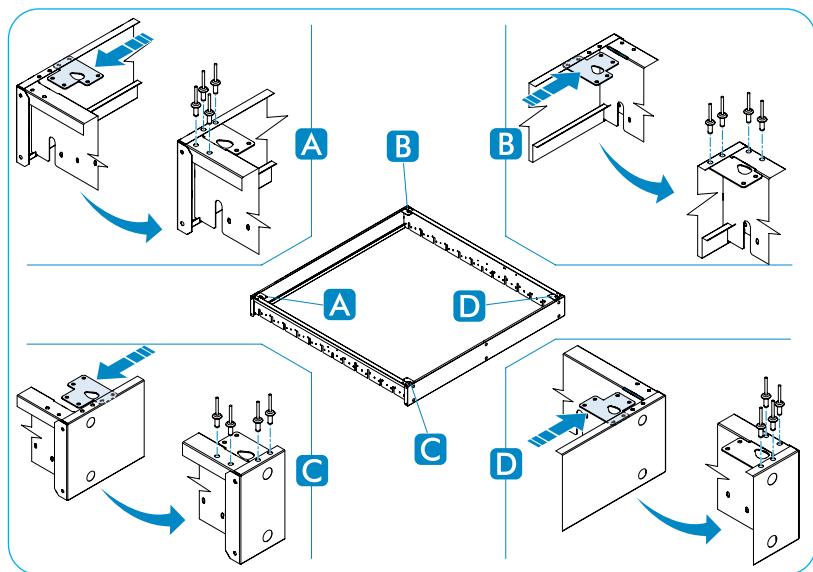

Bolts & Nuts / Viti e dadi / Vis et écrous / Schrauben und Schraubenmuttern / Tornillos y tuercas / Parafusos e porcas



# Op.19 AGS gear unit assembly (RIGHT) / Montaggio gruppo ingranaggi AGS (DX) / Montage groupe d'engrenages AGS (DROITE) / Montage der Zahnradbaugruppe AGS (RECHTS) / Montaje grupo engranajes AGS (DCHO) / Montagem do grupo de engranagens AGS (DIR)



Tools / Utensili / Ustensiles / Werkzeuge / Instrumentos / Ferramentas

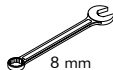
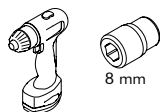

Bolts & Nuts / Viti e dadi / Vis et écrous / Schrauben und Schraubenmuttern / Tornillos y tuercas / Parafusos e porcas

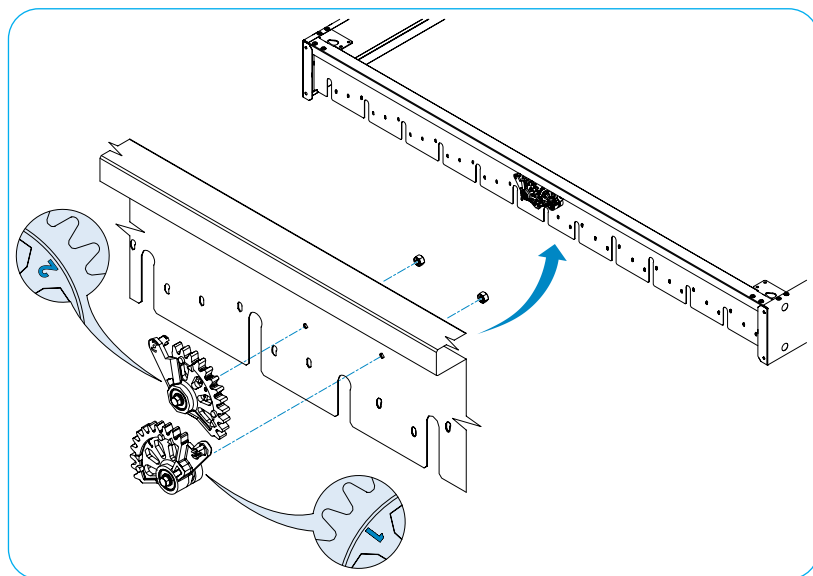
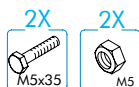



**Op.20** AGS gear unit assembly (LEFT) / Montaggio gruppo ingranaggi AGS (SX) / Montage groupe d'engrenages AGS (GAUCHE) / Montage der Zahnradbaugruppe AGS (LINKS) / Montaje grupo engranajes AGS (IZQ) / Montagem do grupo de engrenagens (ESQ)

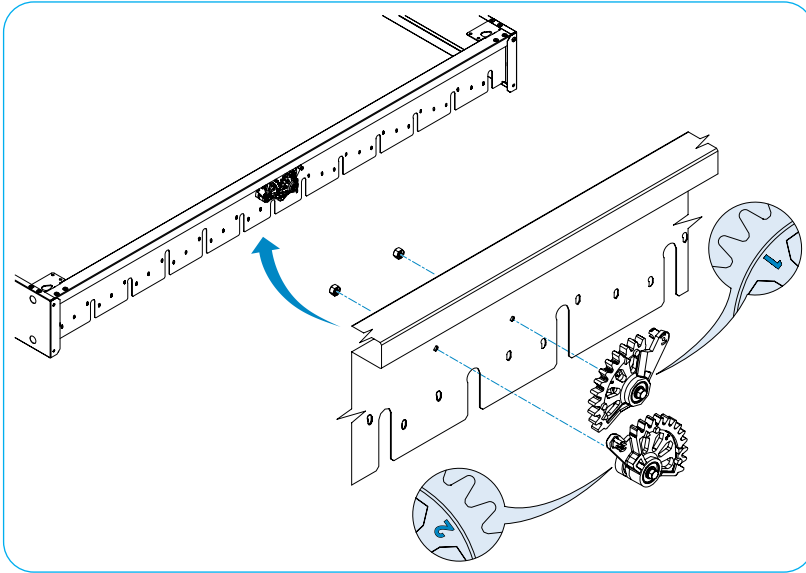

Tools/Utensili/Ústensíles/Werkzeuge / Instrumentos/Ferramentas

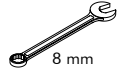
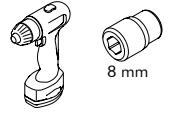

Bolts & Nuts/Viti e dadi/Vis et écrous / Schrauben und Schraubenmüttern / Tornillos y tuercas/Parafusos e porcas

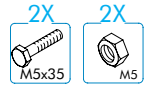

**Op.21** AGS shutter profile assembly (RIGHT) / Montaggio profilo dell'otturatore AGS (DX) / Montage de profilés d'obturateur AGS (DROITE) / Montage der Verschluss AGS (RECHTS) / Montaje de la cerradura AGS (DERECHA) / Montagem da fechadura AGS (DIR)

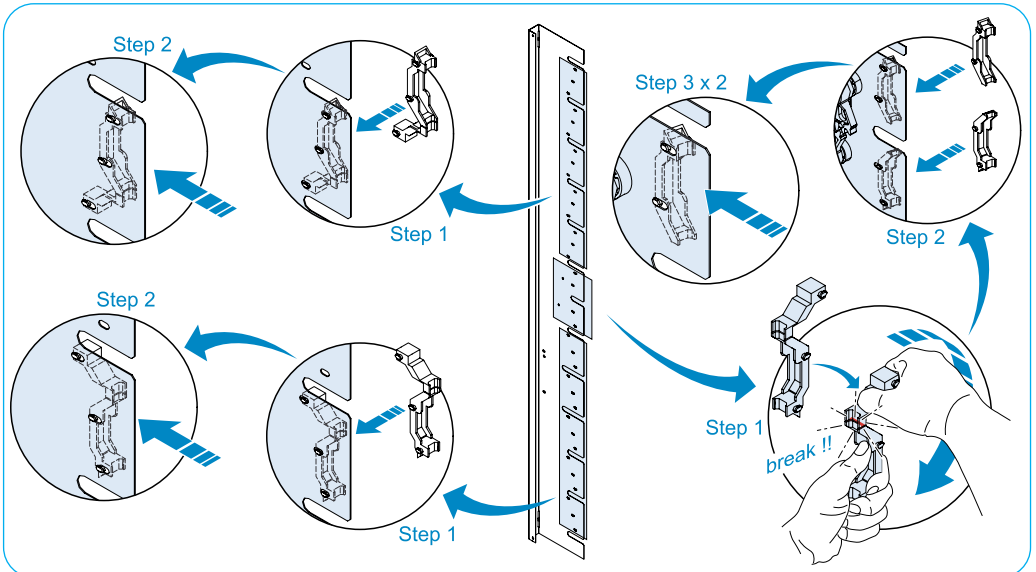

**Op.22** AGS shutter profile assembly (LEFT) / Montaggio profilo dell'otturatore AGS (SX) / Montage de profilés d'obturateur AGS (GAUCHE) / Montage der Verschluss AGS (LINKS) / Montaje de la cerradura AGS (IZQ) / Montagem da fechadura AGS (ESQ)

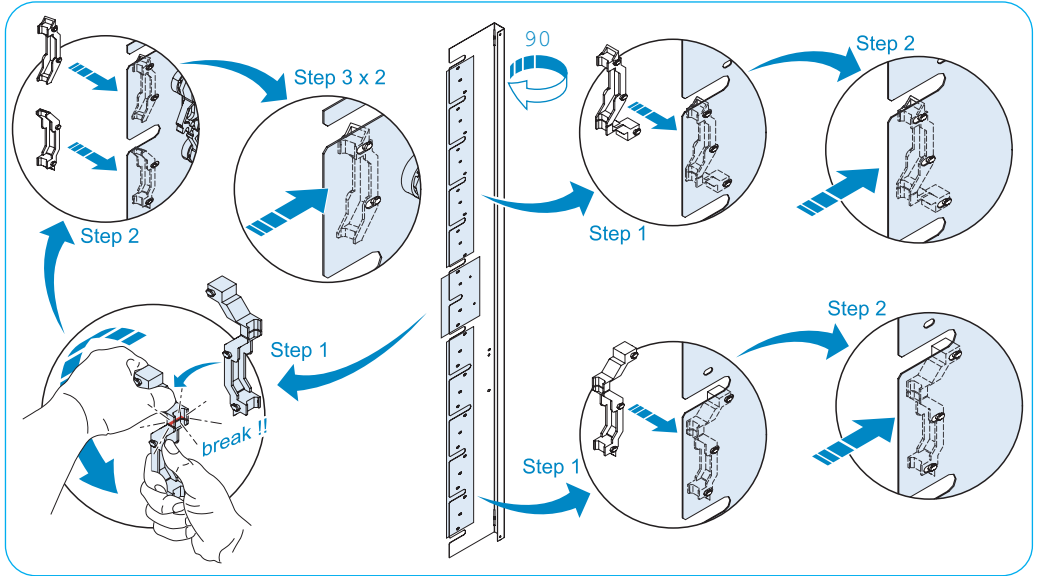

**Op.23** Pallet assembly upper position / Assemblaggio paletta posizione sup. / Assemblage plaque position sup. / Zusammenbau der Schaufel in der oberen Position / Ensamblaje de la paleta en posición sup. / Montagem da paleta de posição sup.

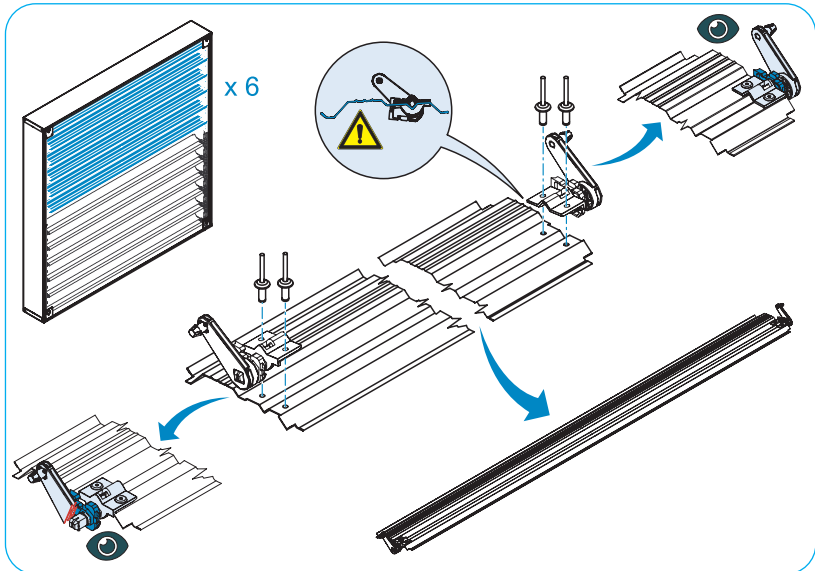

Tools/Utensili/Utensiles/Werkzeuge / Instrumentos/Ferramentas



Bolts & Nuts/Viti e dadi/Vis et écrous / Schrauben und Schraubenmuttern / Tornillos y tuercas/Parafusos e porcas



Op.23 Pallet assembly upper position / Assemblaggio paletta posizione sup. / Assemblage plaque position sup. / Zusammenbau der Schaufel in der oberen Position / Ensamblaje de la paleta en posición sup. / Montagem da paleta de posição sup.

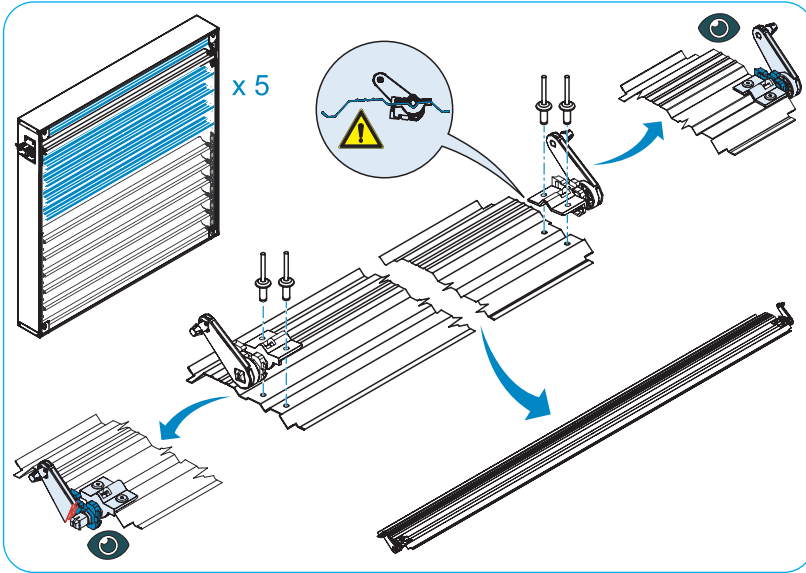

Op.24 Actuator plate assembly / Assemblaggio paletta attuatore / Assemblage plaque de l'actionneur / Zusammenbau der Schaufel für Aktuator / Ensamblaje de la paleta de actuador / Conjunto de pá do atuador

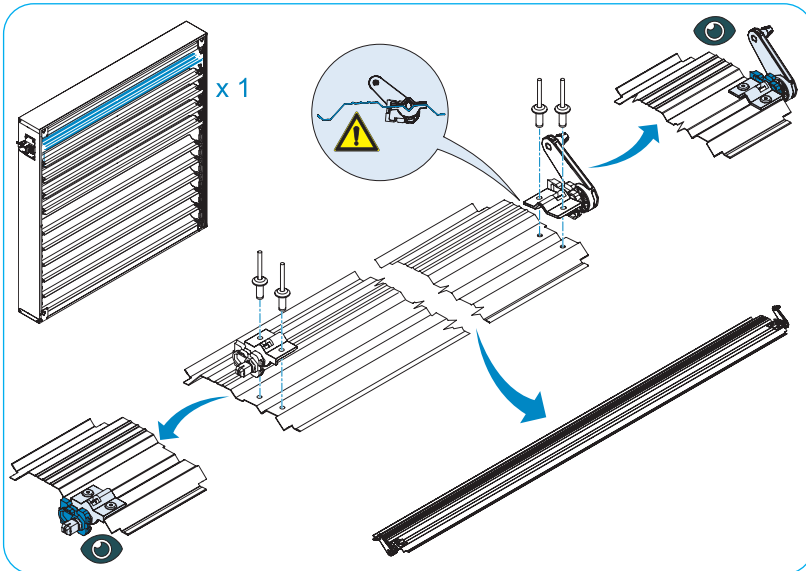

**Op.25** Pallet assembly lower position / Assemblaggio paletta posizione inf. / Assemblage plaque position inf. / Zusammenbau der Schaufel in der unteren Position / Ensamblaje de la paleta en posición inf. / Montagem da paleta de posição inf.



Tools / Utensili / Ustensiles / Werkzeuge / Instrumentos / Ferramentas

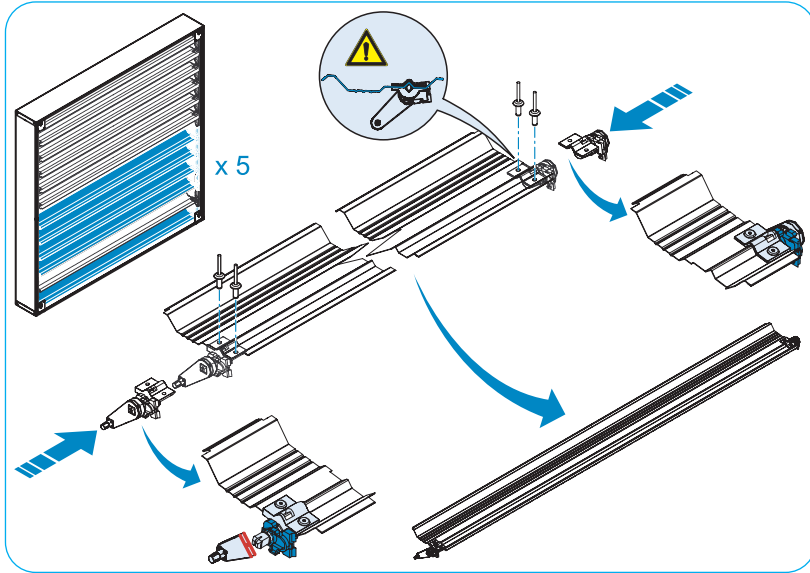

Bolts & Nuts / Viti e dadi / Vis et écrous / Schrauben und Schraubenmutter / Tornillos y tuercas / Parafusos e porcas



**Op.25** Pallet assembly lower position / Assemblaggio paletta posizione inf. / Assemblage plaque position inf. / Zusammenbau der Schaufel in der unteren Position / Ensamblaje de la paleta en posición inf. / Montagem da paleta de posição inf.



Tools / Utensili / Ustensiles / Werkzeuge / Instrumentos / Ferramentas

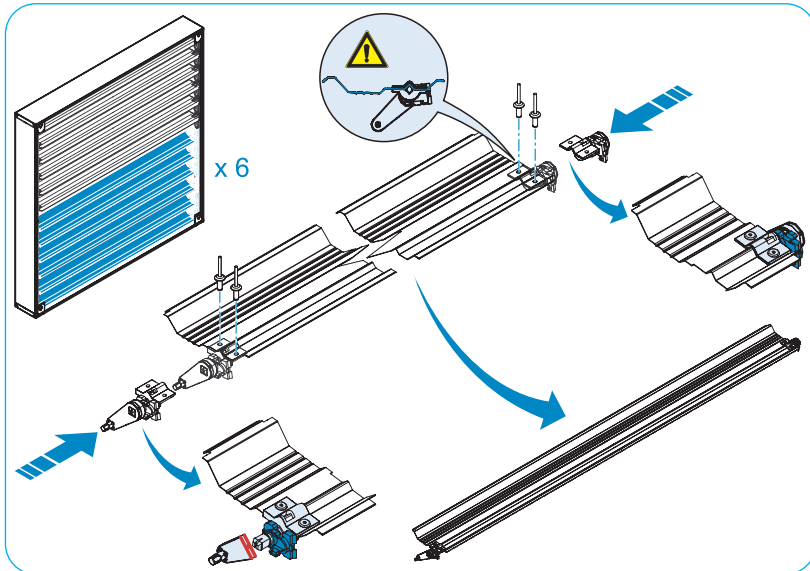

Bolts & Nuts / Viti e dadi / Vis et écrous / Schrauben und Schraubenmutter / Tornillos y tuercas / Parafusos e porcas



Op.26 Actuated blade assembly / Assemblaggio paletta per molla / Assemblage plaque pour molette / Zusammenbau der Schaufel für Feder / Ensamblaje de la paleta con resorte / Montagem da paleta para mola



Tools/Utensili/Utensiles/Werkzeuge / Instrumentos/Ferramentas

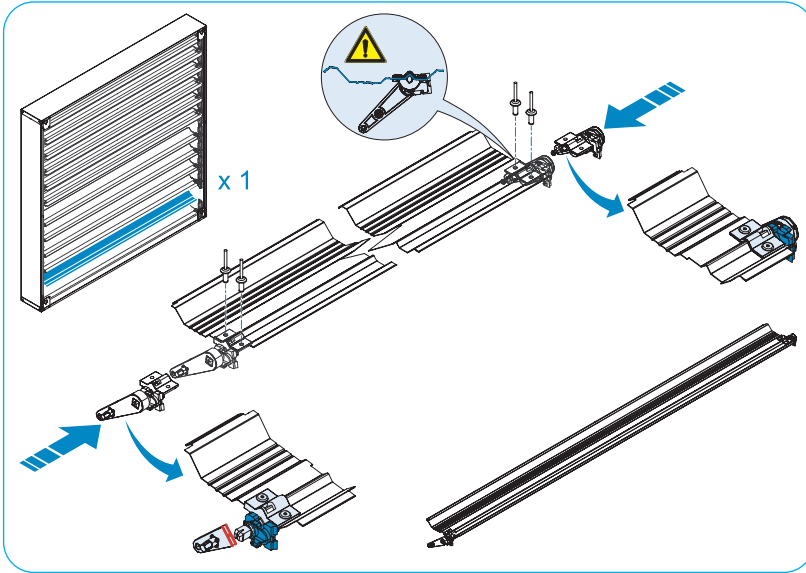

Bolts & Nuts/Viti e dadi/Vis et écrous / Schrauben und Schraubmüttern / Tornillos y tuercas/Parafusos e porcas



Op.27 Pallet assembly upper position / Montaggio palette posiz superiore / Montage plaques pos. supérieure / Montage der Schaufel in der oberen Position / Montaje de las paletas en posición sup. / Montagem da paleta posic. superior

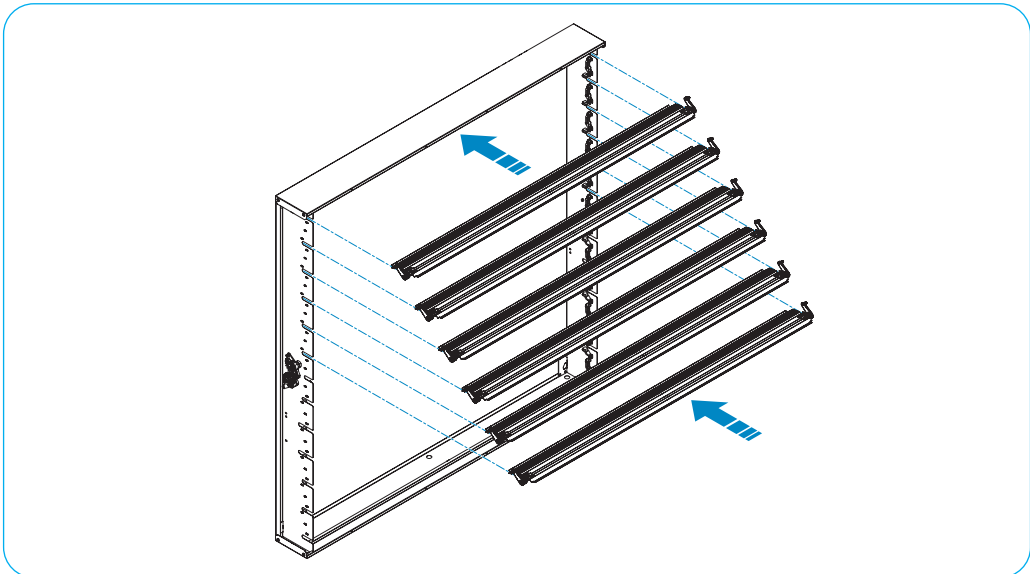

**Op.27** Pallet assembly upper position / Montaggio palette posiz superiore / Montage plaques pos. supérieure / Montage der Schaufel in der oberen Position / Montaje de las paletas en posición sup. / Montagem da paleta posic. superior

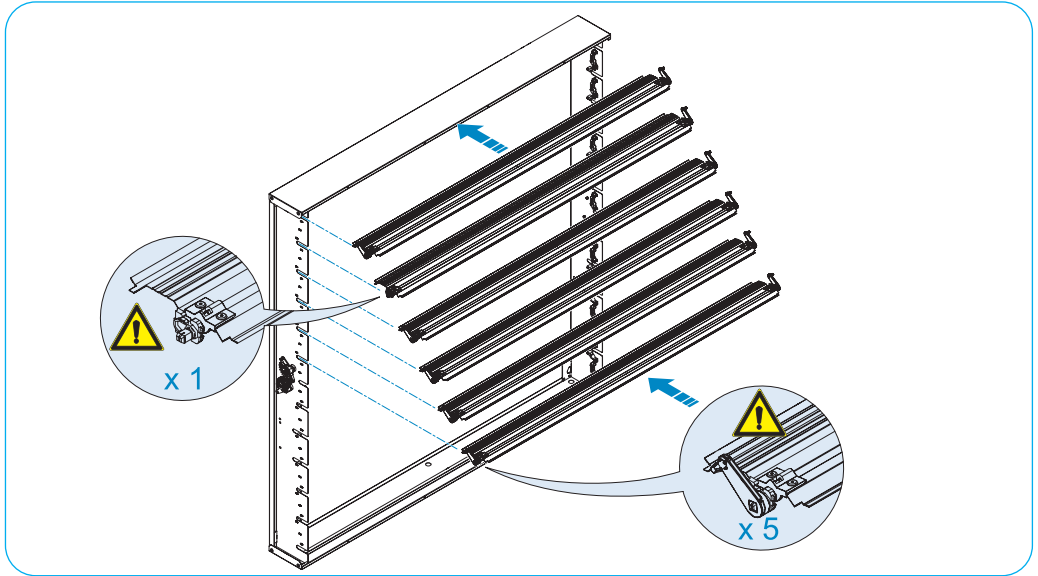

**Op.28** Mounting of pallet caps / Montaggio tappi palette / Montage des obturateurs de plaques / Montage der Schaufelkappen / Montaje de los tapones de las paletas / Montagem de tampus de paleta

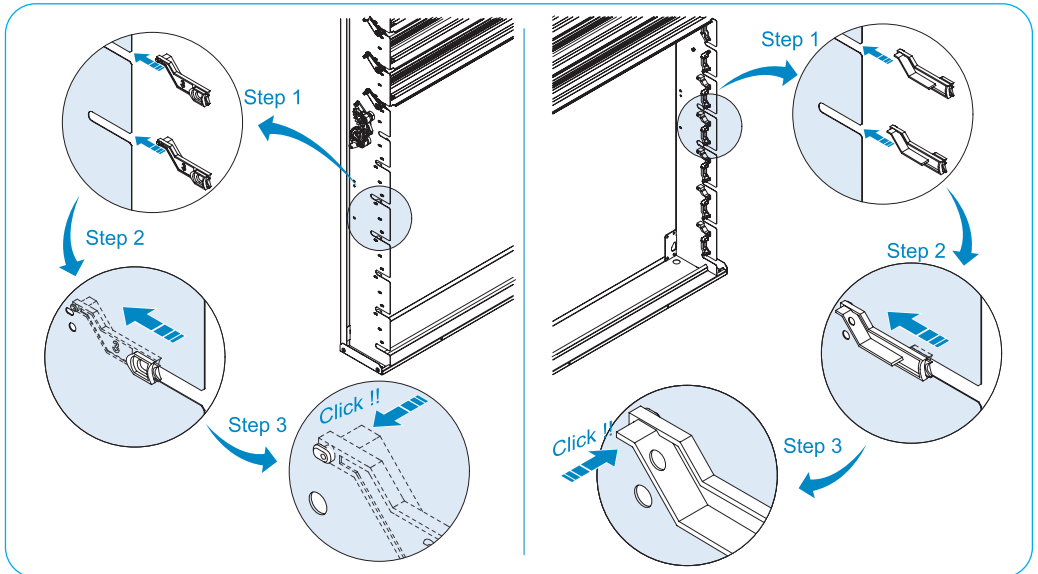

Op.29 Assembly of pallets lower position / Montaggio palette posizione inf. / Montage plaques position inf. / Montage der Schaufel in der unteren Position / Montaje de las paletas en posición inf. / Montagem da paleta de posição inf.

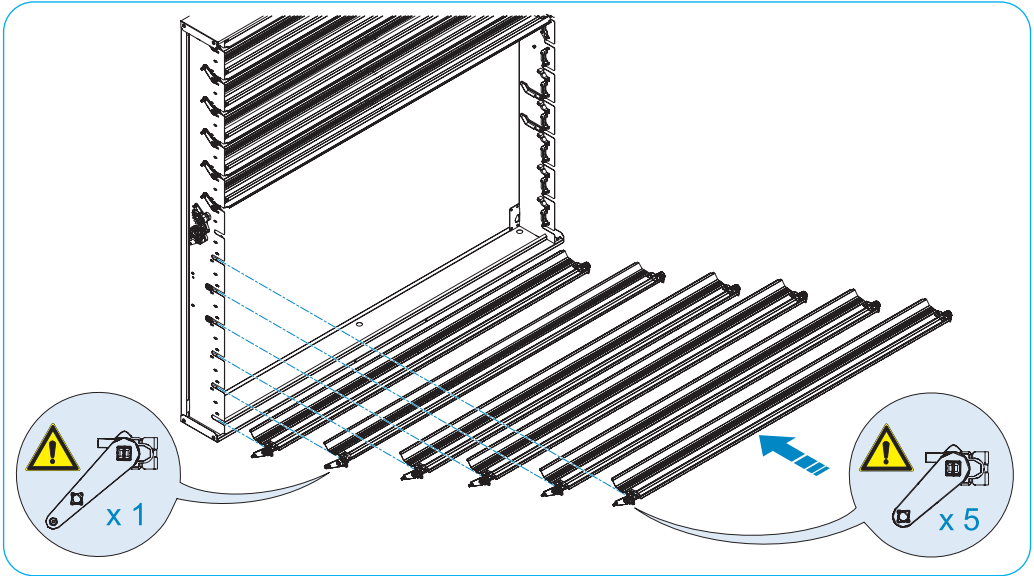

Op.29 Assembly of pallets lower position / Montaggio palette posizione inf. / Montage plaques position inf. / Montage der Schaufel in der unteren Position / Montaje de las paletas en posición inf. / Montagem da paleta de posição inf.

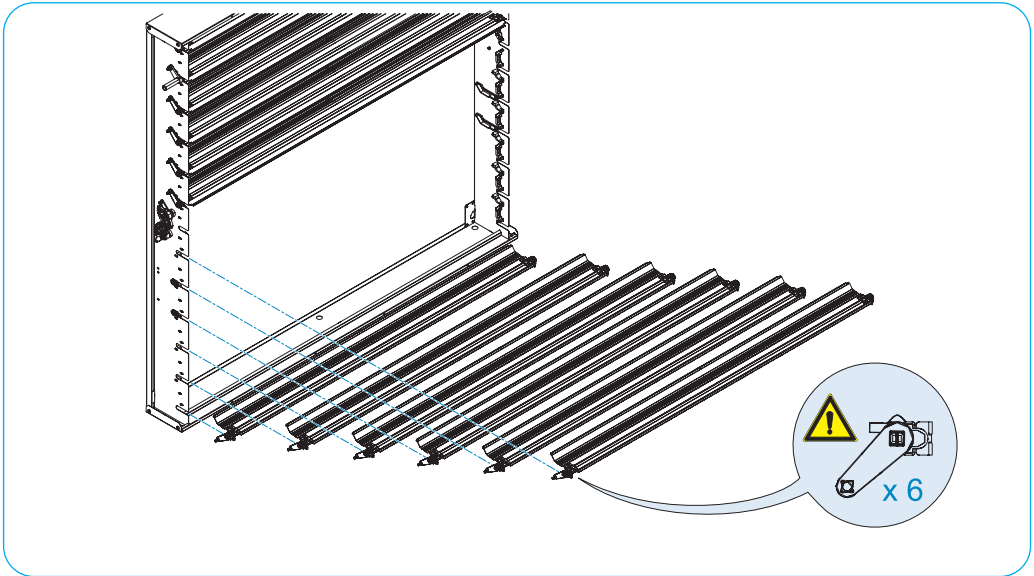

**Op.30** Central stop assembly / Assemblaggio battuta centrale / Assemblage de l'arrêt central /  
Zusammenbau zentrale Anschlaggruppe / Ensamblaje de percutor central / Montagem do  
calço central

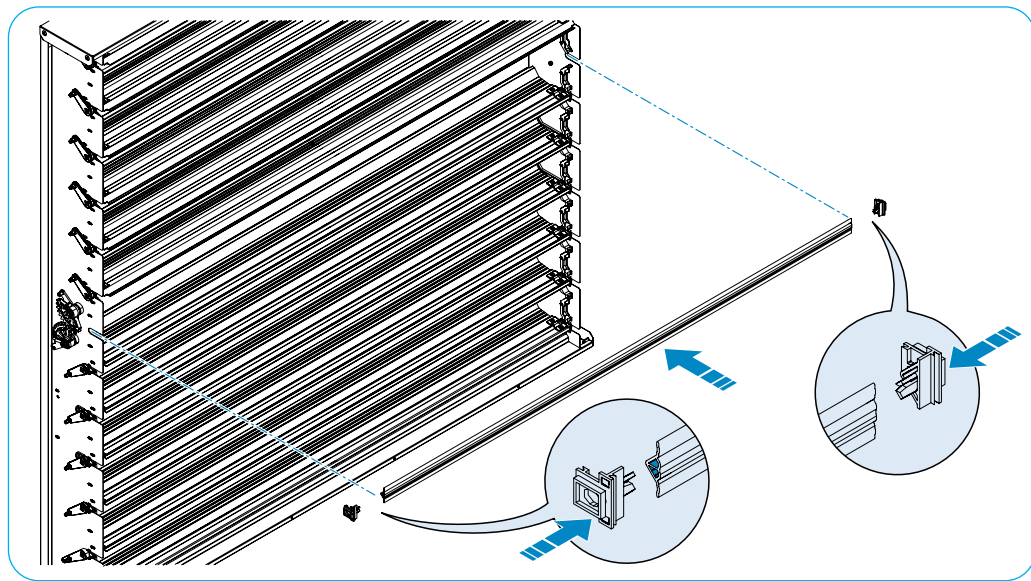

**Op.31** Tie rod assembly / Assemblaggio tiranti / Assemblage des tirants / Zusammenbau Zug-  
stangen / Ensamblaje de los tirantes / Montagem de tirantes

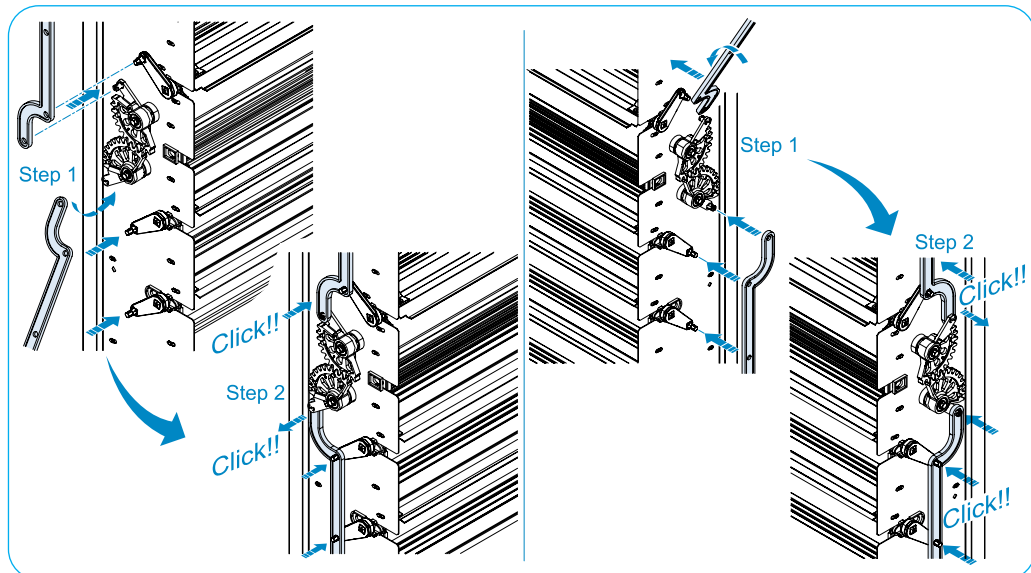



Op.32 Mounting of springs/ Montaggio molle / Montage du ressort / Einbau der Federn /  
Montaje de los muelles / Montagem de molas

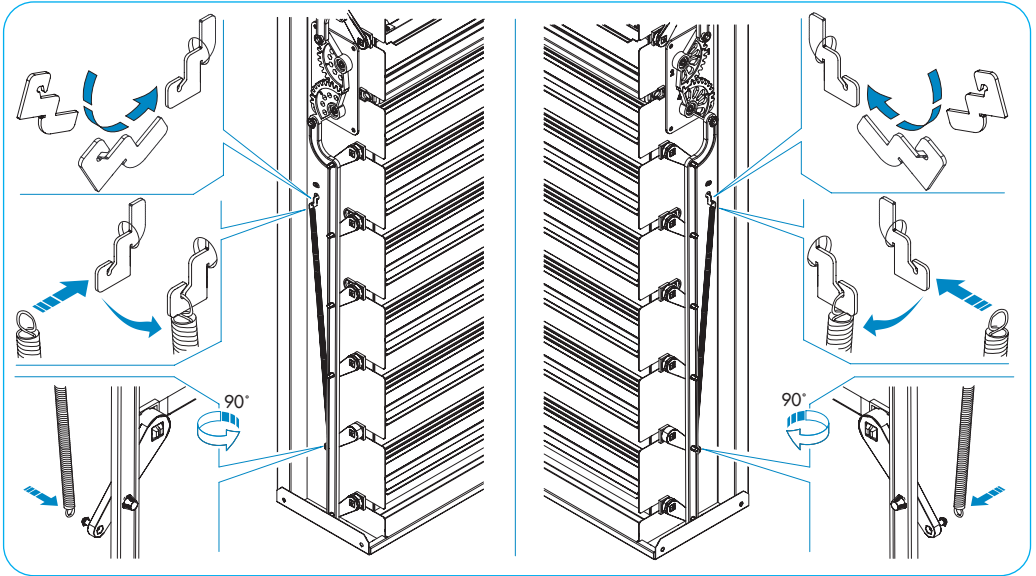

**Op.33** Side panels fixing / Fissaggio pannelli laterali / Fixation des panneaux latéraux / Befestigung der Seitenpaneele / Fijación de los paneles laterales / Fixação dos painéis laterais



Tools/Utensili/Utensiles/Werkzeuge /Instrumentos/Ferramentas



Bolts & Nuts/Viti e dadi/Vis et écrous /Schrauben und Schraubenmütern/ Tornillos y tuercas/Parafusos e porcas

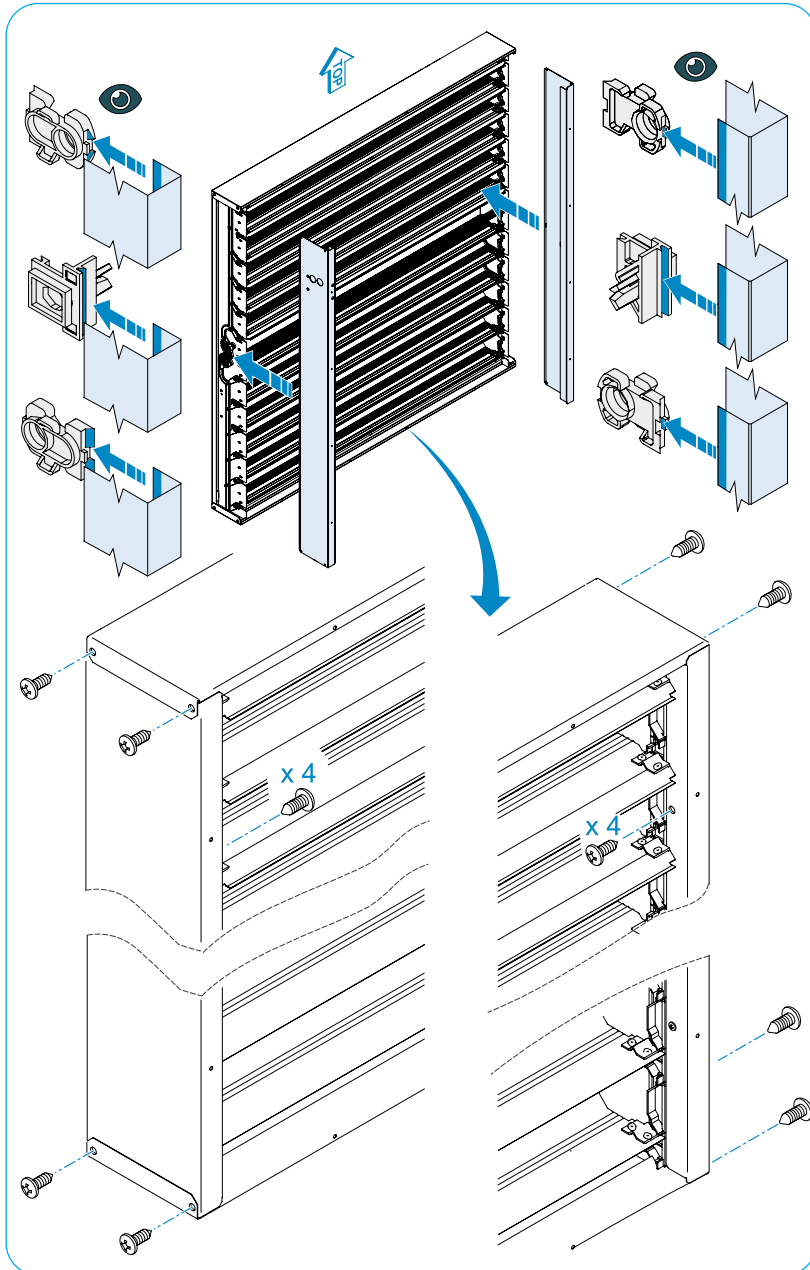

Op.34 Actuador assembly / Montaggio attuatore / Montage de l'actionneur / Montage Antrieb / Montaje del actuador / Montagem do atuador

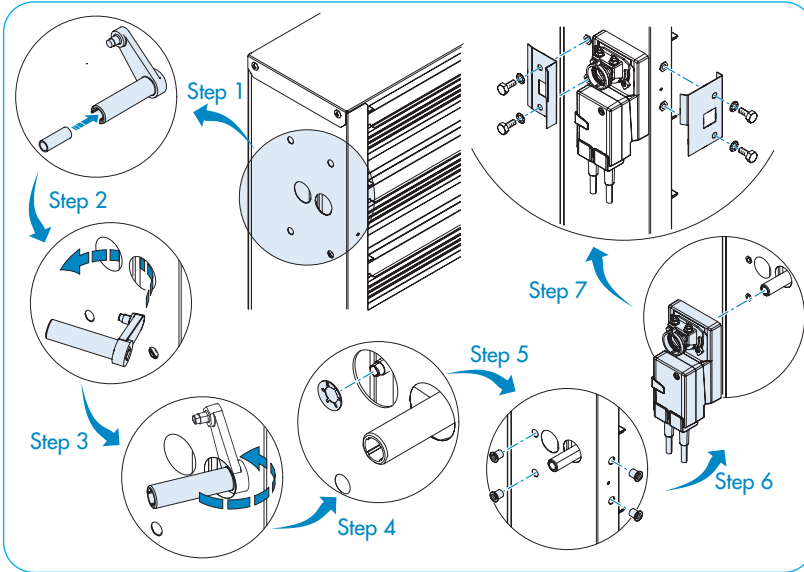

Tools/Utensili/Utensiles/Werkzeuge / Instrumentos/Ferramentas

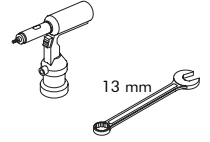

Bolts & Nuts/Viti e dadi/Vis et écrous / Schrauben und Schraubenmuttern / Tornillos y tuercas/Parafusos e porcas

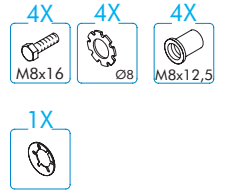

Op.35 Aqs mounting on fan / Montaggio Aqs su ventilatore / Montage des Aqs sur le ventilateur / Einbau der AGS auf dem Ventilator / Montaje Aqs en el ventilador / Montagem Aqs no ventilador

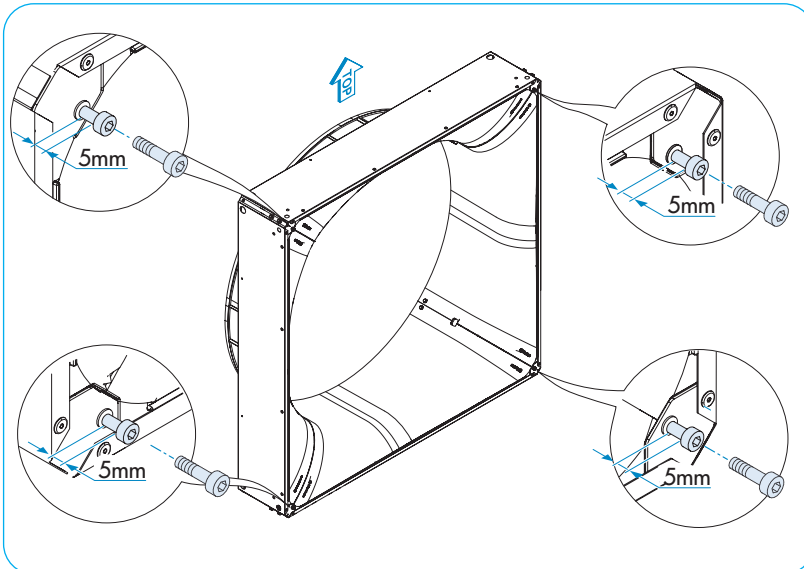

Tools/Utensili/Utensiles/Werkzeuge / Instrumentos/Ferramentas

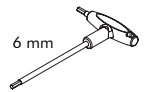

Bolts & Nuts/Viti e dadi/Vis et écrous / Schrauben und Schraubenmuttern / Tornillos y tuercas/Parafusos e porcas



**Op.36** Ags mounting on fan / Montaggio Ags su ventilatore / Montage des Ags sur le ventilateur / Einbau der AGS auf dem Ventilator / Montaje Ags en el ventilador / Montagem Ags no ventilador



Tools / Utensili / Ustensiles / Werkzeuge / Instrumentos / Ferramentas

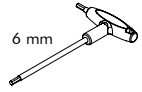
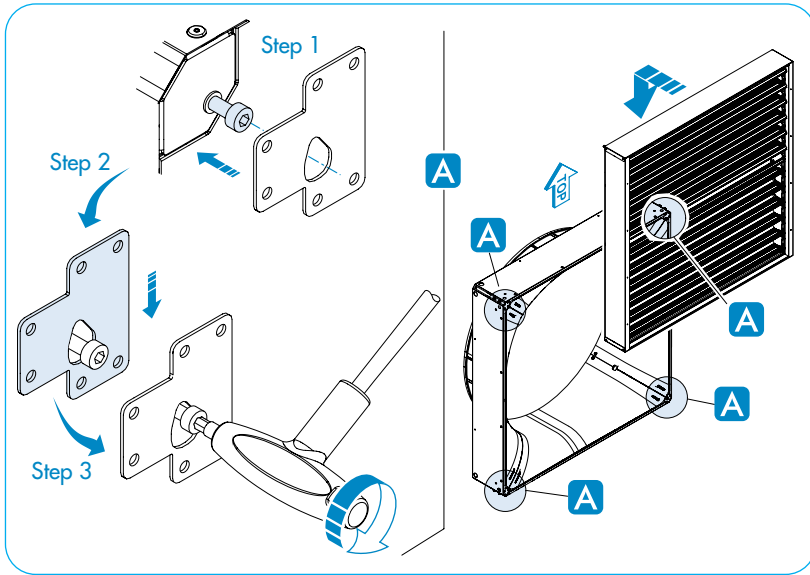

Bolts & Nuts / Viti e dadi / Vis et écrous / Schrauben und Schraubenmutter / Tornillos y tuercas / Parafusos e porcas

**Op.37** AGS grille mounting (Optional) / Montaggio griglia AGS (Opzionale) / Montage grille AGS (en option) / Montage des AGS-Gitters (optional) / Montaje rejilla AGS (opcional) / Montagem da grelha AGS (Opcional)



Tools / Utensili / Ustensiles / Werkzeuge / Instrumentos / Ferramentas

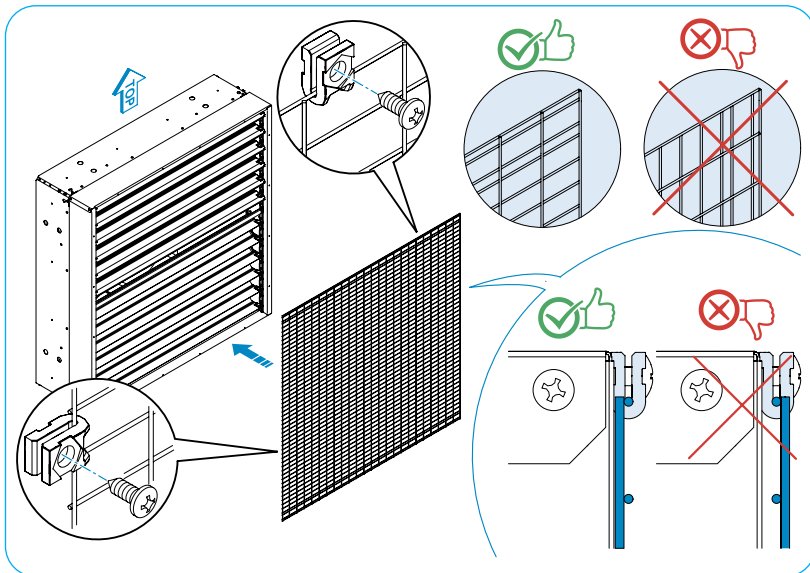

Bolts & Nuts / Viti e dadi / Vis et écrous / Schrauben und Schraubenmutter / Tornillos y tuercas / Parafusos e porcas



- GB** ASSEMBLY OF AIR EXTRACTION CONE UNIT
- I** MONTAGGIO GRUPPO CONO DI SCARICO ARIA
- F** MONTAGE DU GROUPE DU CÔNE D'ÉVACUATION DE L'AIR
- D** MONTAGE LUFTAUSTRITTSKEGELEINHEIT
- E** MONTAJE GRUPO CONO DE SALIDA DE AIRE
- P** MONTAGEM DO GRUPO DO CONE DE DESCARGA DE AR

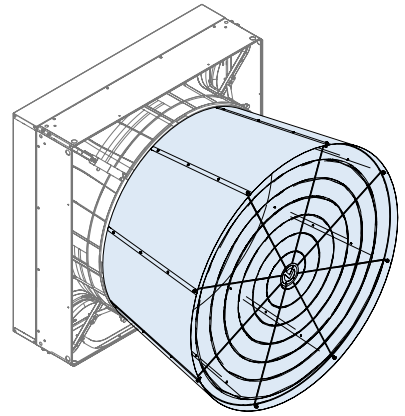

**Op.38** Cone brackets mounting / Montaggio staffe cono / Montage des équerres du cône / Montage der Kegelhalterungen / Montaje de los estribos del cono / Montagem dos suportes do cone



Tools/Utensili/Utensiles/Werkzeuge / Instrumentos/Ferramentas

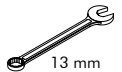
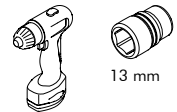
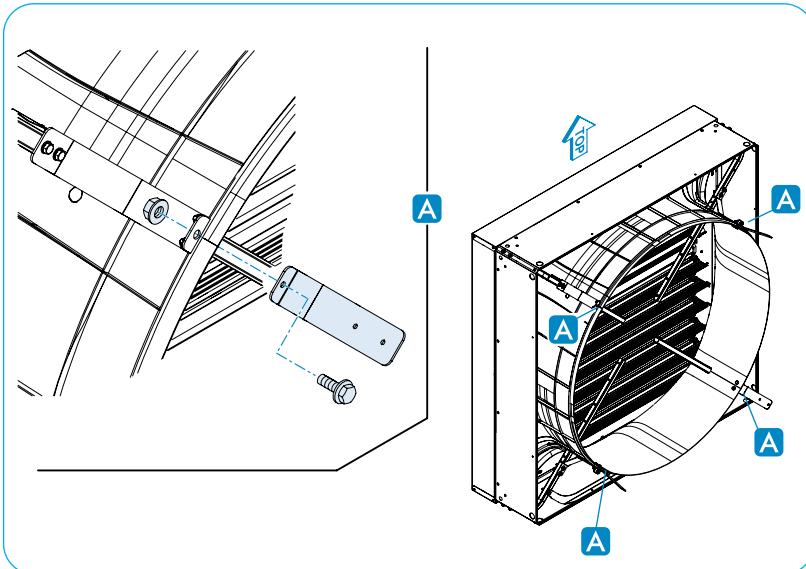

Bolts & Nuts/Viti e dadi/Vis et écrous / Schrauben und Schraubenmuttern / Tornillos y tuercas/Parafusos e porcas

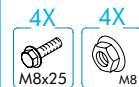

# Op.39 Cone brackets mounting / Montaggio staffe cono / Montage des équerres du cône / Montage der Kegelhalterungen / Montaje de los estribos del cono / Montagem dos suportes do cone



Tools/Utensili/Utensiles/Werkzeuge /Instrumentos/Ferramentas



Bolts & Nuts/Viti e dadi/Vis et écrous /Schrauben und Schraubenmuttern/ Tornillos y tuercas/Parafusos e porcas

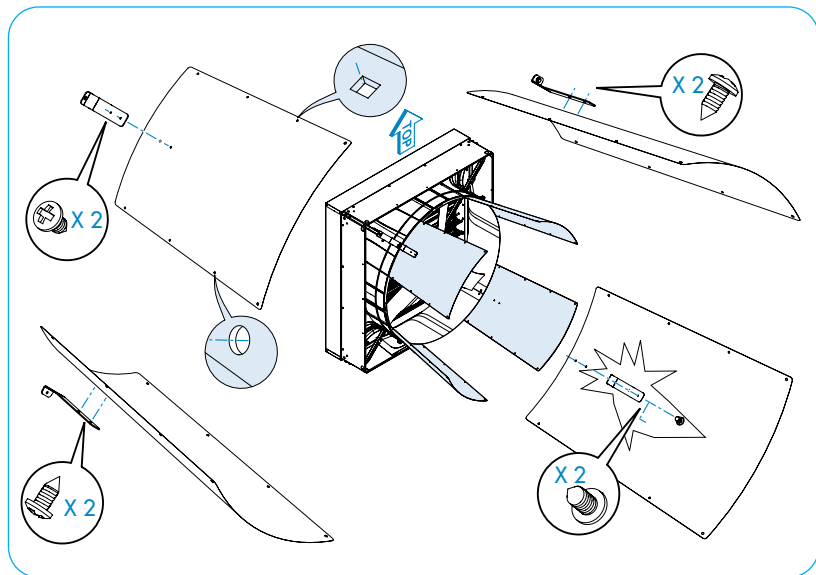

# Op.40 Cone Mounting / Montaggio Cono / Montage du cône / Montage des Kegels / Montaje del cono / Montagem do cone



Tools/Utensili/Utensiles/Werkzeuge /Instrumentos/Ferramentas



Bolts & Nuts/Viti e dadi/Vis et écrous /Schrauben und Schraubenmuttern/ Tornillos y tuercas/Parafusos e porcas

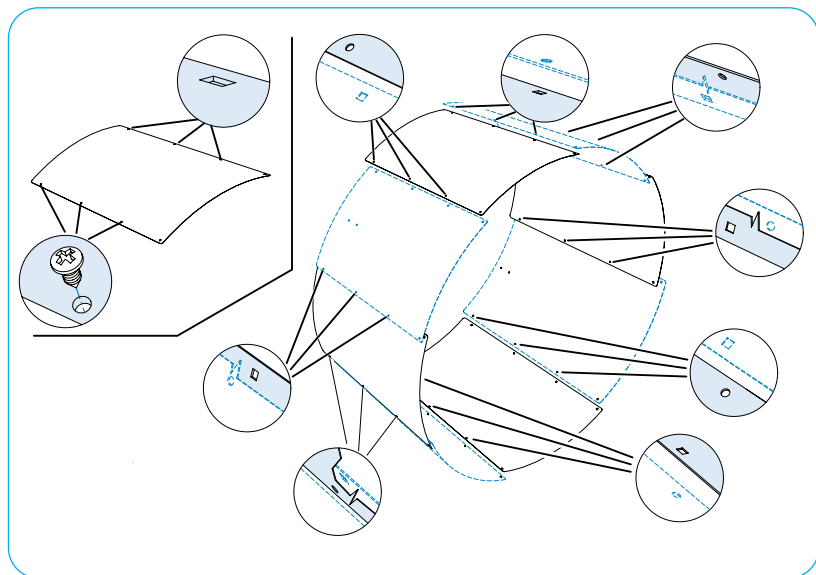

## Op.41 Mounting of cone protection grille / Montaggio griglia protezione Cono / Montage grille de protection du cône / Montage des Kegelschutzgitters / Montaje rejilla de protección del cono / Montagem da grelha de proteção do cone



Tools/Utensili/Utensiles/Werkzeuge / Instrumentos/Ferramentas

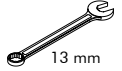

Bolts & Nuts/Viti e dadi/Vis et écrous / Schrauben und Schraubmuttern / Tornillos y tuercas/Parafusos e porcas

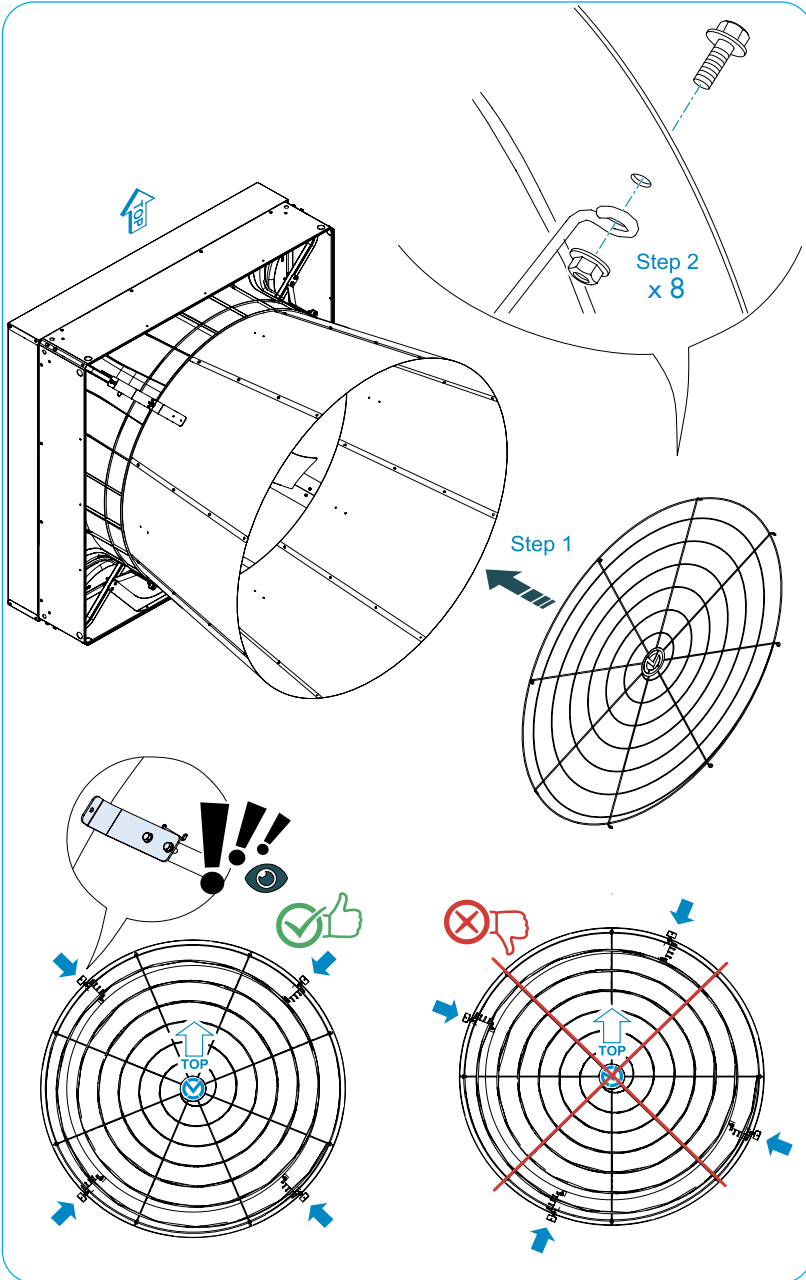
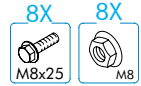



AM\_SaturnONE\_V2\_202403\_Multi  
P/N 2200223

## Munters Italy S.p.A

Strada Piani, 12  
18027 Chiusavecchia (IM), Italy  
Tel: +39 0183 52 11  
Fax: +39 0183 521 333  
email: [info@munters.it](mailto:info@munters.it)

[www.munters.com](http://www.munters.com)

For production or other reasons, after publication © Munters AB, 20200 reserves the right to make changes to specifications, quantities, etc. // Per motivi di produzione o di altro tipo, successivamente alla pubblicazione © Munters AB, 20200 riserva il diritto di apportare modifiche a specifiche, quantità, ecc... // Pour des raisons de production ou autres, après publication © Munters AB, 20200 se réserve le droit d'apporter des modifications aux spécifications, aux quantités, etc. // Aus Produktions- oder anderen Gründen behält sich Munters AB, 20200 nach der Veröffentlichung © Munters AB, 20200 das Recht vor, Änderungen an Spezifikationen, Mengen usw. vorzunehmen. // Por motivos de producción o de otro tipo, después de la publicación, © Munters AB 20200 se reserva el derecho de realizar cambios y modificaciones de las especificaciones, cantidades, etc. // Por motivos de produção ou de outro tipo, posteriores à publicação a © Munters AB, 20200 reserva-se o direito de realizar modificações nas especificações, quantidade, etc.